

MITSUBISHI MICROCOMPUTERS

3803/3804 Group

SINGLE-CHIP 8-BIT CMOS MICROCOMPUTER

DESCRIPTION

The 3803/3804 group is the 8-bit microcomputer based on the 740 family core technology.

The 3803/3804 group is designed for household products, office automation equipment, and controlling systems that require analog signal processing, including the A-D converter and D-A converters.

The 3804 group is the version of the 3803 group to which an I²C-BUS control function has been added.

FEATURES

- Basic machine-language instructions 71
- Minimum instruction execution time 0.25 μ s
(at 16.8 MHz oscillation frequency)
- Memory size
 - ROM 16 K to 32 K bytes
(60 K bytes for flash memory version)
 - RAM 640 to 1024 bytes
(2048 bytes for flash memory version)
- Programmable input/output ports 56
- Software pull-up resistors Built-in
- Interrupts
 - 21 sources, 16 vectors 3803 group
(external 8, internal 12, software 1)
 - 23 sources, 16 vectors 3804 group
(external 9, internal 13, software 1)
- Timers 16-bit X 1
8-bit X 4
(with 8-bit prescaler)
- Watchdog timer 16-bit X 1
- Serial I/O 8-bit X 2 (UART or Clock-synchronized)
8-bit X 1 (Clock-synchronized)
- PWM 8-bit X 1 (with 8-bit prescaler)
- I²C-BUS interface (3804 group only) 1 channel
- A-D converter 10-bit X 16 channels
(8-bit reading enabled)
- D-A converter 8-bit X 2 channels
- LED direct drive port 8
- Clock generating circuit Built-in 2 circuits
(connect to external ceramic resonator or quartz-crystal oscillator)
- Power source voltage
 - In high-, middle-speed mode
 - At 16.8 MHz oscillation frequency 4.5 to 5.5 V
 - At 12.5 MHz oscillation frequency 4.0 to 5.5 V
 - At 8.38 MHz oscillation frequency) 2.7 to 5.5 V*
 - In low-speed mode
 - At 32 kHz oscillation frequency 2.7 to 5.5 V*
- (* This value of flash memory version is 4.0 to 5.5 V.)
- Power dissipation
 - In high-speed mode 60 mW (typ.)
(at 16.8 MHz oscillation frequency, at 5 V power source voltage)
 - In low-speed mode 60 μ W (typ.)
(at 32 kHz oscillation frequency, at 3 V power source voltage)

- Operating temperature range -20 to 85°C
- Packages
 - SP 64P4B (64-pin 750 mil SDIP)
 - FP 64P6N-A (64-pin 14 X 14 mm QFP)
 - HP 64P6Q-A (64-pin 10 X 10 mm LQFP)

<Flash memory mode>

- Supply voltage $V_{CC} = 5 V \pm 10 \%$
- Program/Erase voltage $V_{PP} = 11.7 V$ to 12.6 V
- Programming method Programming in unit of byte
- Erasing method Batch erasing (chip erasing)
- Program/Erase control by software command
- Number of times for programming/erasing 100

Notes

1. The specifications of this product are subject to change because it is under development. Inquire the use of Mitsubishi Electric Corporation.
2. The flash memory version cannot be used for application embedded in the MCU card.

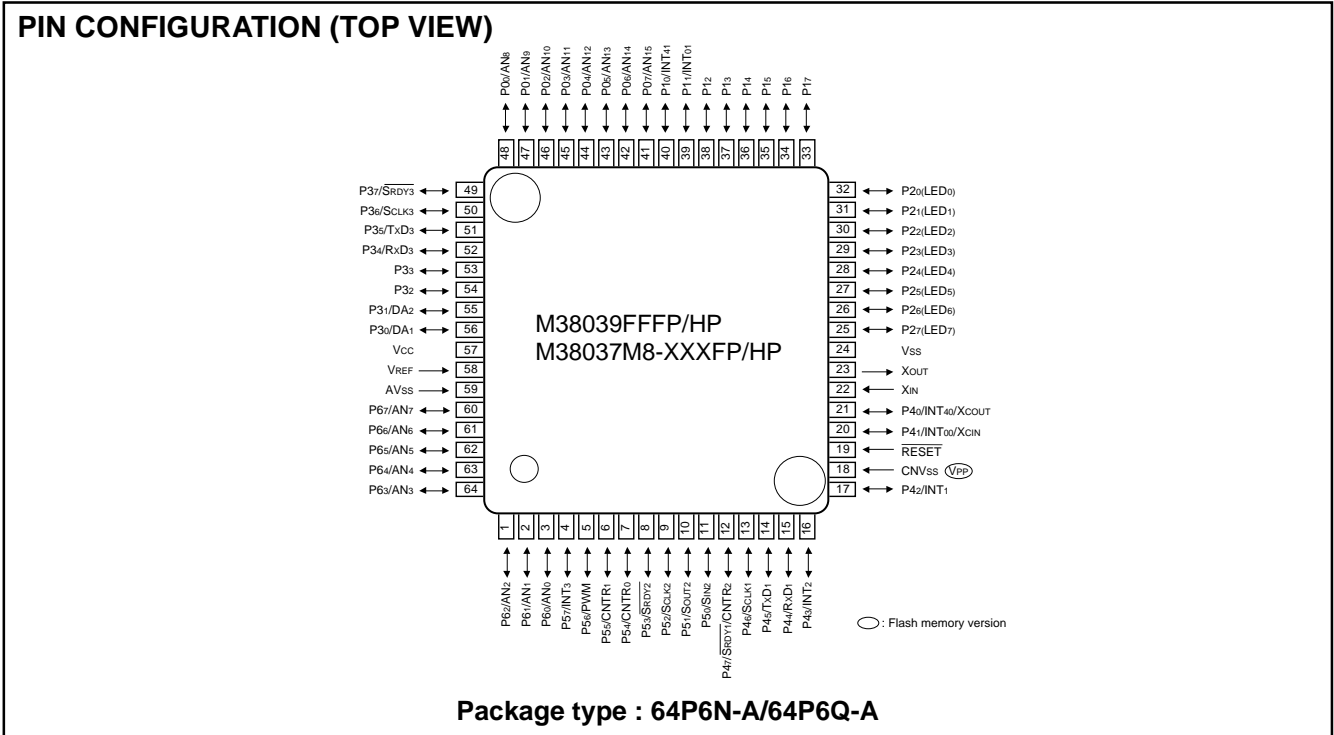

Fig. 1 3803 group pin configuration

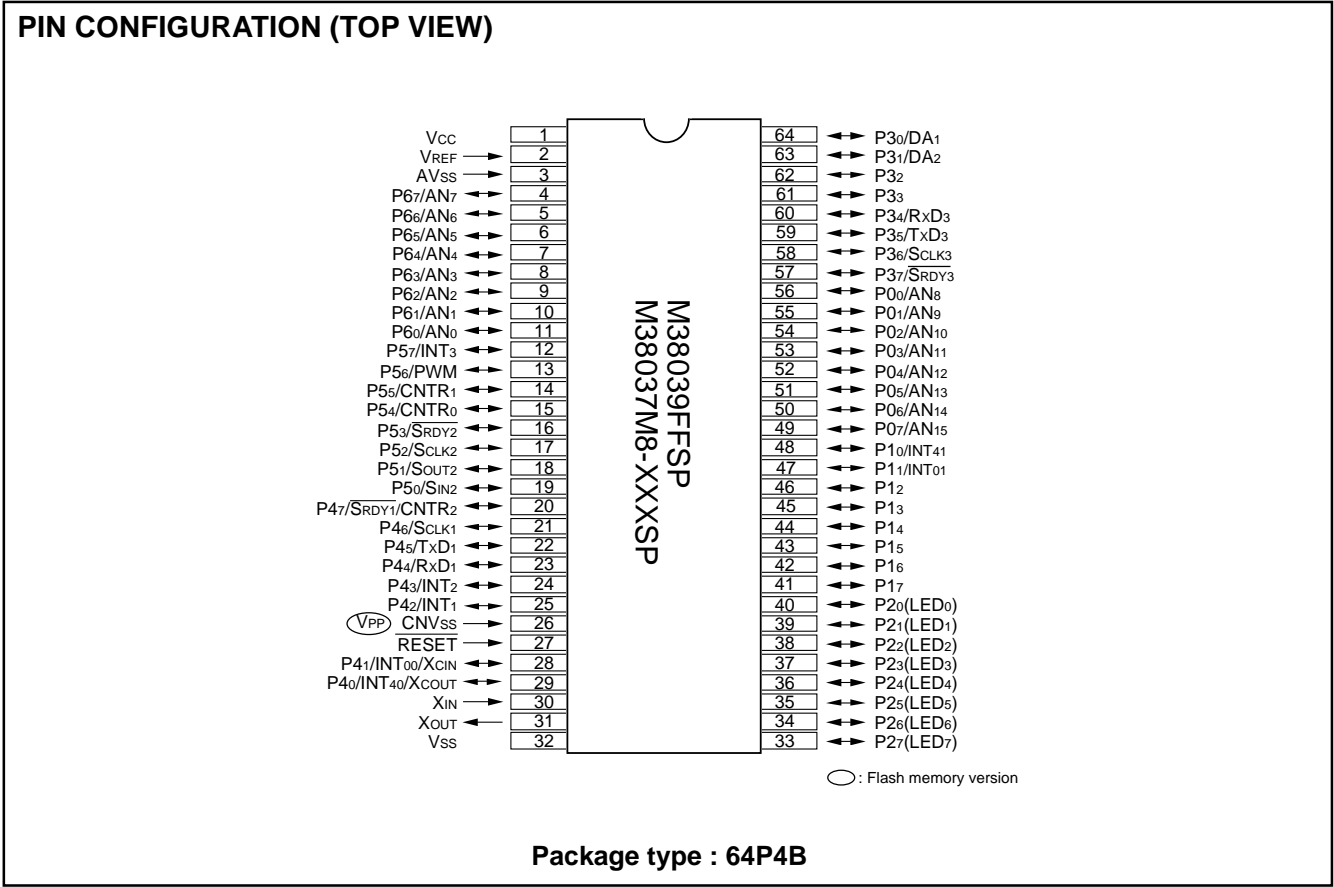

Fig. 2 3803 group pin configuration

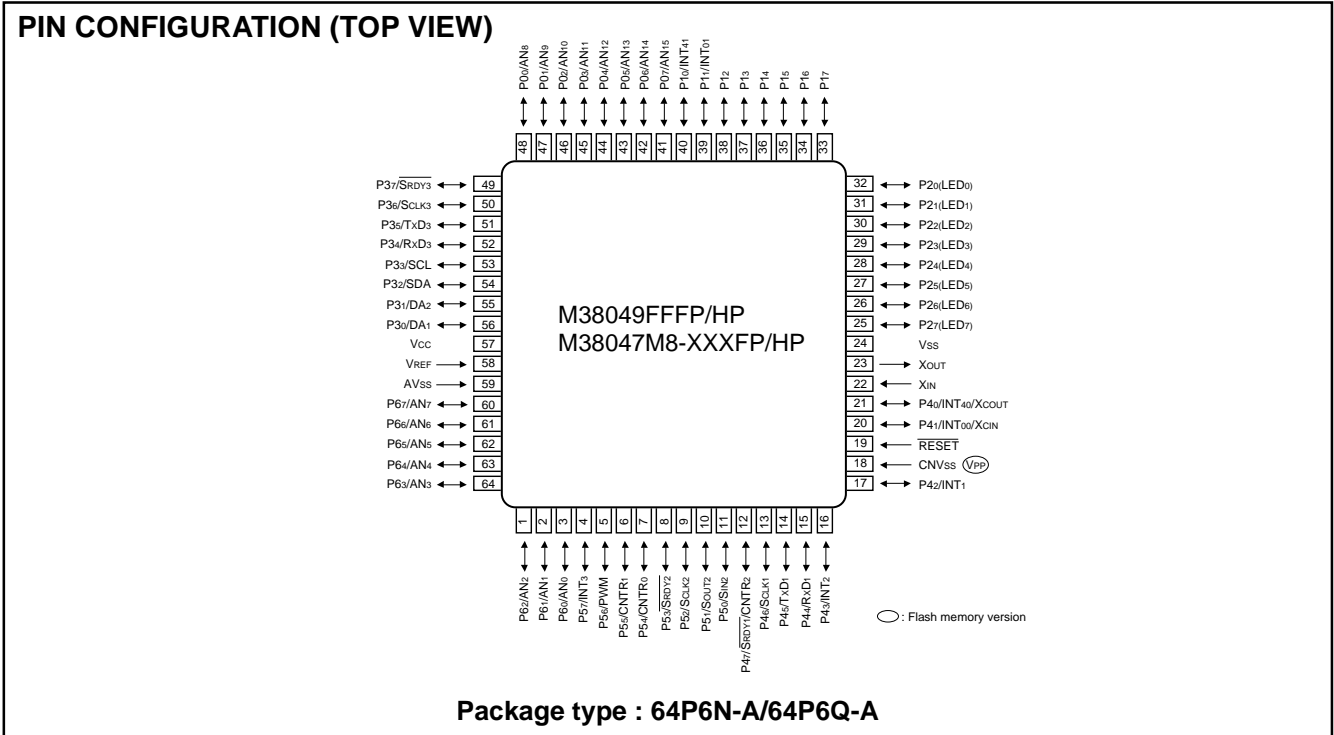

Fig. 3 3804 group pin configuration

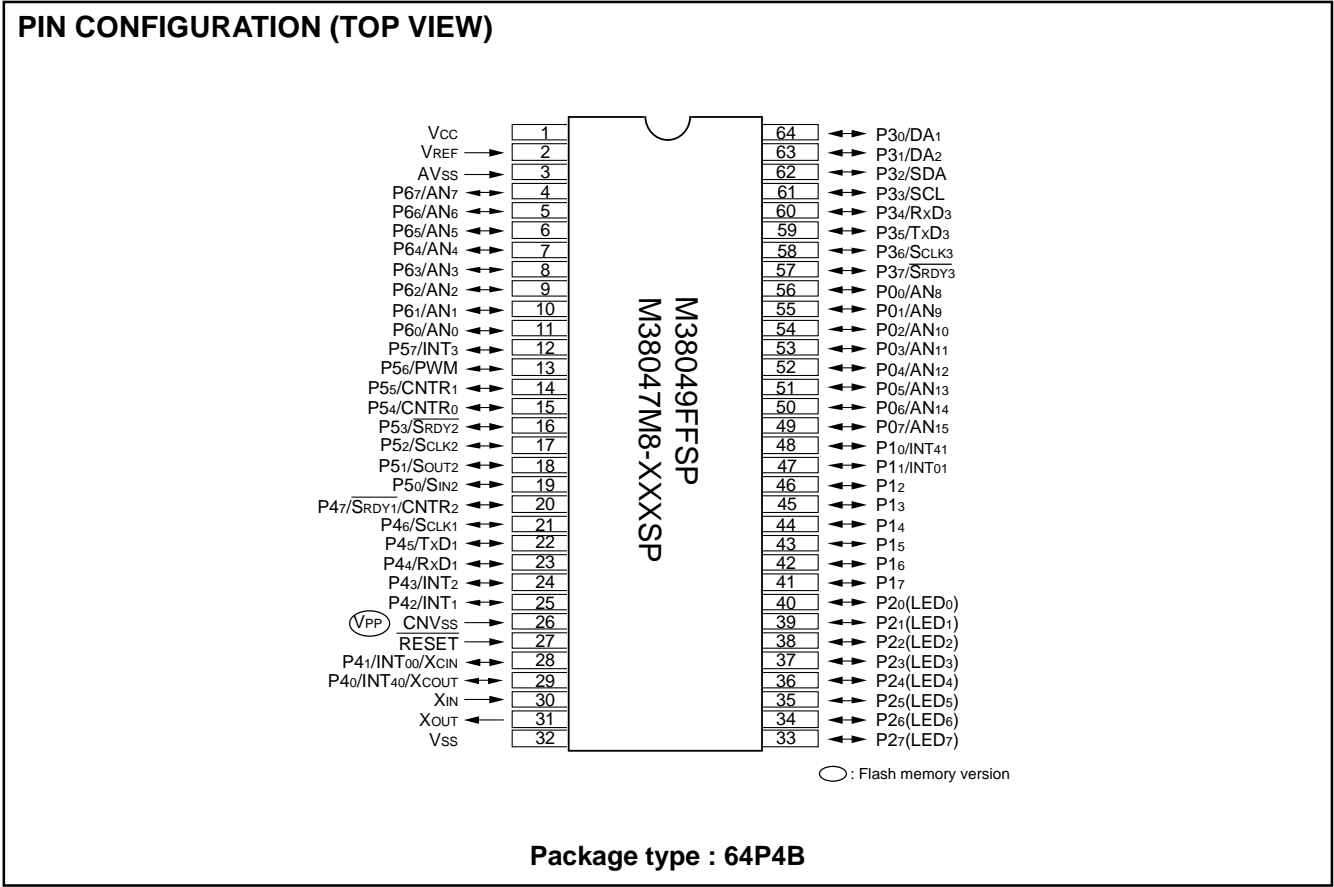
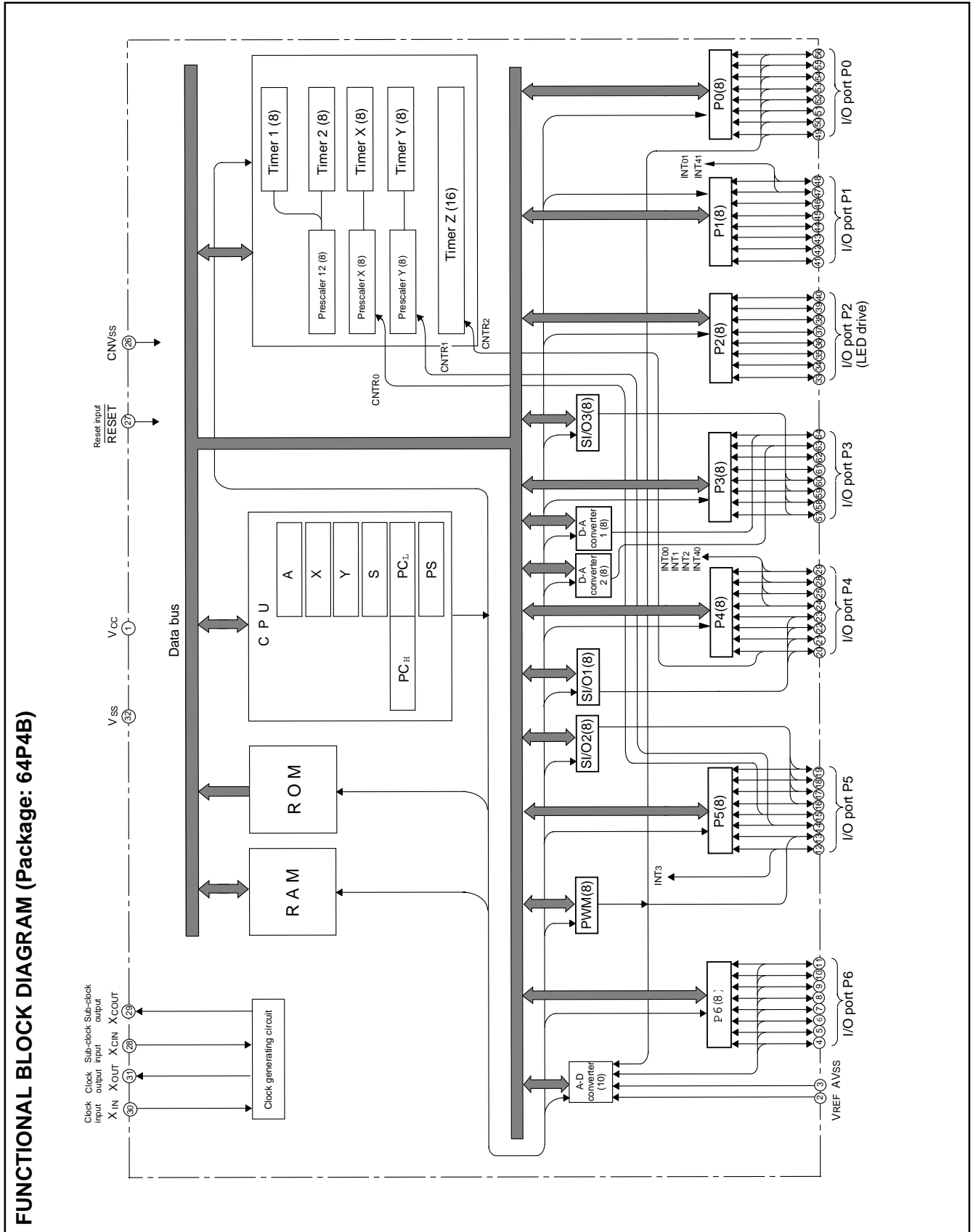

Fig. 4 3804 group pin configuration

FUNCTIONAL BLOCK



FUNCTIONAL BLOCK DIAGRAM (Package: 64P4B)

Fig. 5 3803 group functional block diagram

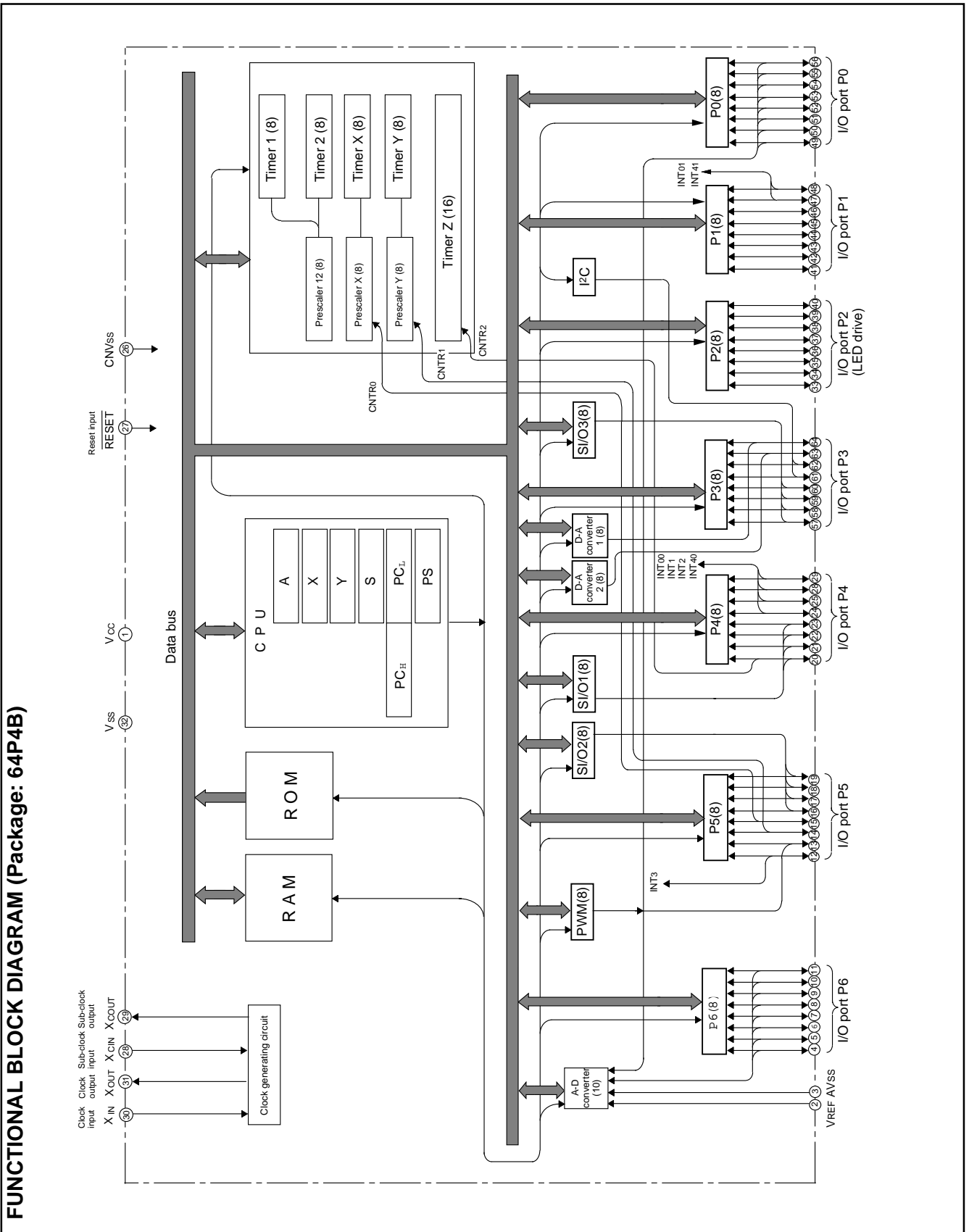

Fig. 6 3804 group functional block diagram

PIN DESCRIPTION

Table 1 Pin description (3803 group)

Pin	Name	Functions	
			Function except a port function
VCC, VSS	Power source	<ul style="list-style-type: none"> •Apply voltage of 2.7 V – 5.5 V to Vcc, and 0 V to Vss. •In the flash memory version, apply voltage of 4.0 V – 5.5 V to Vcc, and 0 V to Vss 	
CNVSS	CNVSS input	<ul style="list-style-type: none"> •This pin controls the operation mode of the chip. •Normally connected to VSS. •In the flash memory version, this becomes VPP power source input pin. 	
VREF	Reference voltage	<ul style="list-style-type: none"> •Reference voltage input pin for A-D and D-A converters. 	
AVSS	Analog power source	<ul style="list-style-type: none"> •Analog power source input pin for A-D and D-A converters. •Connect to VSS. 	
RESET	Reset input	<ul style="list-style-type: none"> •Reset input pin for active "L". 	
XIN	Clock input	<ul style="list-style-type: none"> •Input and output pins for the clock generating circuit. •Connect a ceramic resonator or quartz-crystal oscillator between the XIN and XOUT pins to set the oscillation frequency. 	
XOUT	Clock output	<ul style="list-style-type: none"> •When an external clock is used, connect the clock source to the XIN pin and leave the XOUT pin open. 	
P00/AN8– P07/AN15	I/O port P0	<ul style="list-style-type: none"> •8-bit CMOS I/O port. •I/O direction register allows each pin to be individually programmed as either input or output. •CMOS compatible input level. •CMOS 3-state output structure. 	•A-D converter input pin
P10/INT01 P11/INT41	I/O port P1		•Interrupt input pin
P12–P17			
P20–P27	I/O port P2		<ul style="list-style-type: none"> •Pull-up control is enabled in a bit unit. •P20–P27 are enabled to output large current for LED drive.
P30/DA1 P31/DA2	I/O port P3	<ul style="list-style-type: none"> •8-bit CMOS I/O port. •I/O direction register allows each pin to be individually programmed as either input or output. •P30, P31, P34–P37 are CMOS 3-state output structure. •P32, P33 are N-channel open-drain output structure. •Pull-up control of P30, P31, P34–P37 is enabled in a bit unit. 	•D-A converter input pin
P32, P33			
P34/RxD3 P35/TxD3 P36/SCLK3 P37/SRDY3			•Serial I/O3 function pin
P40/INT40/ XCOUT P41/INT00/ XCIN	I/O port P4	<ul style="list-style-type: none"> •8-bit CMOS I/O port. •I/O direction register allows each pin to be individually programmed as either input or output. •CMOS compatible input level. •CMOS 3-state output structure. •Pull-up control is enabled in a bit unit. 	•Interrupt input pin
P42/INT1 P43/INT2			•Sub-clock generating I/O pin (resonator connected)
P44/RxD1 P45/TxD1 P46/SCLK1			•Interrupt input pin
P47/SRDY1 /CNTR2			•Serial I/O1, timer Z function pin
P50/SIN2 P51/SOUT2 P52/SCLK2 P53/SRDY2	I/O port P5	<ul style="list-style-type: none"> •8-bit CMOS I/O port. •I/O direction register allows each pin to be individually programmed as either input or output. •CMOS compatible input level. •CMOS 3-state output structure. •Pull-up control is enabled in a bit unit. 	•Serial I/O2 function pin
P54/CNTR0			•Timer X function pin
P55/CNTR1			•Timer Y function pin
P56/PWM			•PWM output pin
P57/INT3			•Interrupt input pin
P60/AN0– P67/AN7			I/O port P6

Table 2 Pin description (3804 group)

Pin	Name	Functions	
			Function except a port function
Vcc, Vss	Power source	<ul style="list-style-type: none"> Apply voltage of 2.7 V – 5.5 V to Vcc, and 0 V to Vss. In the flash memory version, apply voltage of 4.0 V – 5.5 V to Vcc, and 0 V to Vss 	
CNVss	CNVss input	<ul style="list-style-type: none"> This pin controls the operation mode of the chip. Normally connected to Vss. In the flash memory version, this becomes VPP power source input pin. 	
VREF	Reference voltage	<ul style="list-style-type: none"> Reference voltage input pin for A-D and D-A converters. 	
AVSS	Analog power source	<ul style="list-style-type: none"> Analog power source input pin for A-D and D-A converters. Connect to Vss. 	
RESET	Reset input	<ul style="list-style-type: none"> Reset input pin for active "L". 	
XIN	Clock input	<ul style="list-style-type: none"> Input and output pins for the clock generating circuit. Connect a ceramic resonator or quartz-crystal oscillator between the XIN and XOUT pins to set the oscillation frequency. 	
XOUT	Clock output	<ul style="list-style-type: none"> When an external clock is used, connect the clock source to the XIN pin and leave the XOUT pin open. 	
P00/AN8–P07/AN15	I/O port P0	<ul style="list-style-type: none"> 8-bit CMOS I/O port. I/O direction register allows each pin to be individually programmed as either input or output. CMOS compatible input level. CMOS 3-state output structure. Pull-up control is enabled in a bit unit. P20–P27 are enabled to output large current for LED drive. 	<ul style="list-style-type: none"> A-D converter input pin
P10/INT01 P11/INT41	I/O port P1		<ul style="list-style-type: none"> Interrupt input pin
P12–P17			
P20–P27	I/O port P2		
P30/DA1 P31/DA2	I/O port P3	<ul style="list-style-type: none"> 8-bit CMOS I/O port. I/O direction register allows each pin to be individually programmed as either input or output. P32 to P33 can be switched between CMOS compatible input level or SMBUS input level in the I²C-BUS interface function. P30, P31, P34–P37 are CMOS 3-state output structure. P32, P33 are N-channel open-drain output structure. Pull-up control of P30, P31, P34–P37 is enabled in a bit unit. 	<ul style="list-style-type: none"> D-A converter input pin
P32/SDA P33/SCL			<ul style="list-style-type: none"> I²C-BUS interface function pins
P34/RxD3 P35/TxD3 P36/SCLK3 P37/SRDY3			<ul style="list-style-type: none"> Serial I/O3 function pin
P40/INT40/ XCOUT P41/INT00/ XCIN	I/O port P4	<ul style="list-style-type: none"> 8-bit CMOS I/O port. I/O direction register allows each pin to be individually programmed as either input or output. CMOS compatible input level. CMOS 3-state output structure. Pull-up control is enabled in a bit unit. 	<ul style="list-style-type: none"> Interrupt input pin Sub-clock generating I/O pin (resonator connected)
P42/INT1 P43/INT2			<ul style="list-style-type: none"> Interrupt input pin
P44/RxD1 P45/TxD1 P46/SCLK1			<ul style="list-style-type: none"> Serial I/O1 function pin
P47/SRDY1 /CNTR2			<ul style="list-style-type: none"> Serial I/O1, timer Z function pin
P50/SIN2 P51/SOUT2 P52/SCLK2 P53/SRDY2	I/O port P5	<ul style="list-style-type: none"> 8-bit CMOS I/O port. I/O direction register allows each pin to be individually programmed as either input or output. CMOS compatible input level. CMOS 3-state output structure. Pull-up control is enabled in a bit unit. 	<ul style="list-style-type: none"> Serial I/O2 function pin
P54/CNTR0			<ul style="list-style-type: none"> Timer X function pin
P55/CNTR1			<ul style="list-style-type: none"> Timer Y function pin
P56/PWM			<ul style="list-style-type: none"> PWM output pin
P57/INT3			<ul style="list-style-type: none"> Interrupt input pin
P60/AN0–P67/AN7	I/O port P6		<ul style="list-style-type: none"> A-D converter input pin

PART NUMBERING

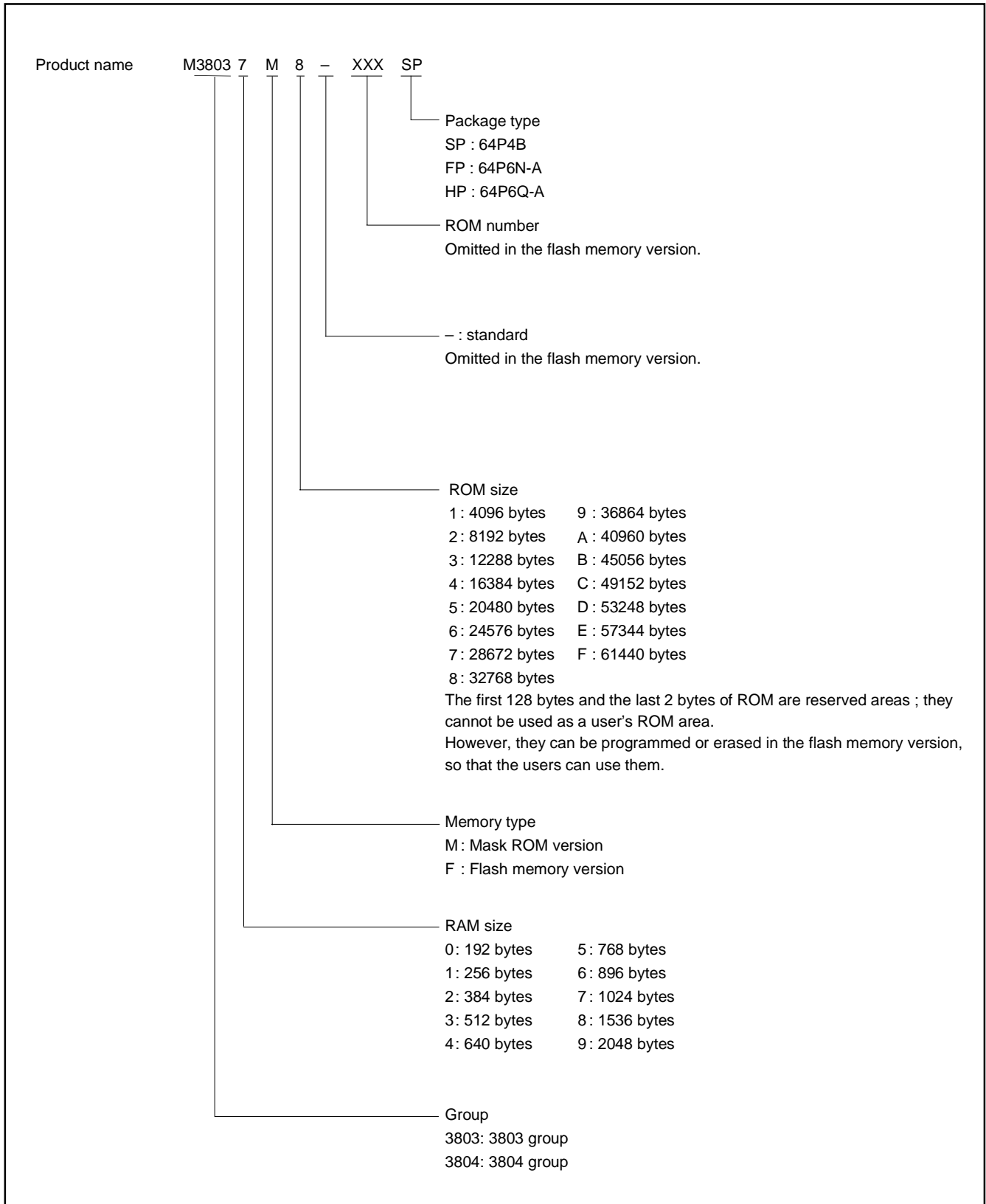

Fig. 7 Part numbering

GROUP EXPANSION

Mitsubishi plans to expand the 3803/3804 group as follows.

Memory Type

Support for mask ROM and flash memory versions.

Memory Size

Flash memory size 60 K bytes
 Mask ROM size 16 K to 32 K bytes
 RAM size 640 to 2048 bytes

Packages

64P4B 64-pin shrink plastic-molded DIP
 64P6N-A 0.8 mm-pitch plastic molded QFP
 64P6Q-A 0.5 mm-pitch plastic molded LQFP

Memory Expansion Plan

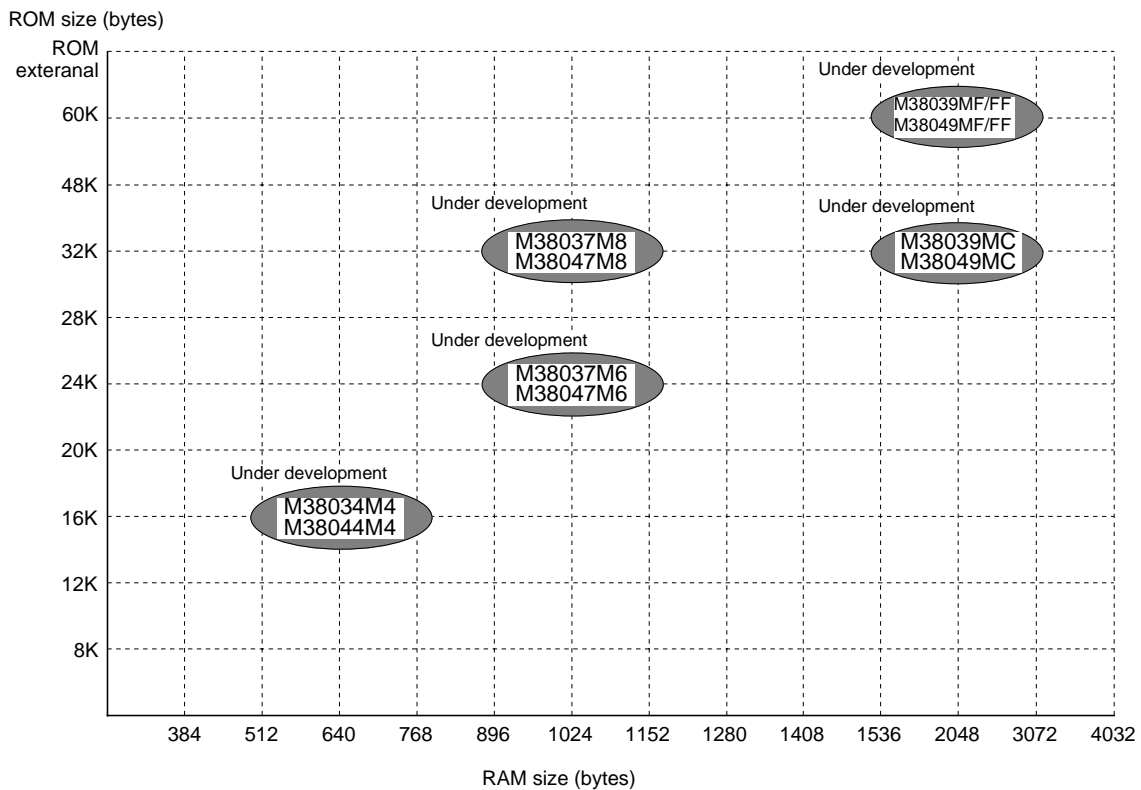

Products under development or planning: the development schedule and specification may be revised without notice. The development of planning products may be stopped.

Fig. 8 Memory expansion plan

Currently planning products are listed below.

Table 3 Support products

As of Aug. 1999

Product name	ROM size (bytes) ROM size for User in ()	RAM size (bytes)	Package	Remarks
M38034M4-XXXSP	16384 (16254)	640	64P4B	Mask ROM version
M38034M4-XXXFP			64P6N-A	
M38034M4-XXXHP			64P6Q-A	
M38044M4-XXXSP			64P4B	
M38044M4-XXXFP			64P6N-A	
M38044M4-XXXHP			64P6Q-A	
M38037M6-XXXSP	24576 (24446)	1024	64P4B	Mask ROM version
M38037M6-XXXFP			64P6N-A	
M38037M6-XXXHP			64P6Q-A	
M38047M6-XXXSP			64P4B	
M38047M6-XXXFP			64P6N-A	
M38047M6-XXXHP			64P6Q-A	
M38037M8-XXXSP	32768 (32638)	1024	64P4B	Mask ROM version
M38037M8-XXXFP			64P6N-A	
M38037M8-XXXHP			64P6Q-A	
M38047M8-XXXSP			64P4B	
M38047M8-XXXFP			64P6N-A	
M38047M8-XXXHP			64P6Q-A	
M38039MC-XXXSP	49152 (49022)	2048	64P4B	Mask ROM version
M38039MC-XXXFP			64P6N-A	
M38039MC-XXXHP			64P6Q-A	
M38049MC-XXXSP			64P4B	
M38049MC-XXXFP			64P6N-A	
M38049MC-XXXHP			64P6Q-A	
M38039MF-XXXSP	61440 (61310)	2048	64P4B	Mask ROM version
M38039MF-XXXFP			64P6N-A	
M38039MF-XXXHP			64P6Q-A	
M38049MF-XXXSP			64P4B	
M38049MF-XXXFP			64P6N-A	
M38049MF-XXXHP			64P6Q-A	
M38039FFSP	61440	2048	64P4B	Flash memory version
M38039FFFP			64P6N-A	
M38039FFHP			64P6Q-A	
M38049FFSP			64P4B	
M38049FFFP			64P6N-A	
M38049FFHP			64P6Q-A	

FUNCTIONAL DESCRIPTION
CENTRAL PROCESSING UNIT (CPU)

The 3803/3804 group uses the standard 740 Family instruction set. Refer to the table of 740 Family addressing modes and machine instructions or the 740 Family Software Manual for details on the instruction set.

Machine-resident 740 Family instructions are as follows:

- The FST and SLW instructions cannot be used.
- The STP, WIT, MUL, and DIV instructions can be used.

[CPU Mode Register (CPUM)] 003B16

The CPU mode register contains the stack page selection bit, etc.
 The CPU mode register is allocated at address 003B16.

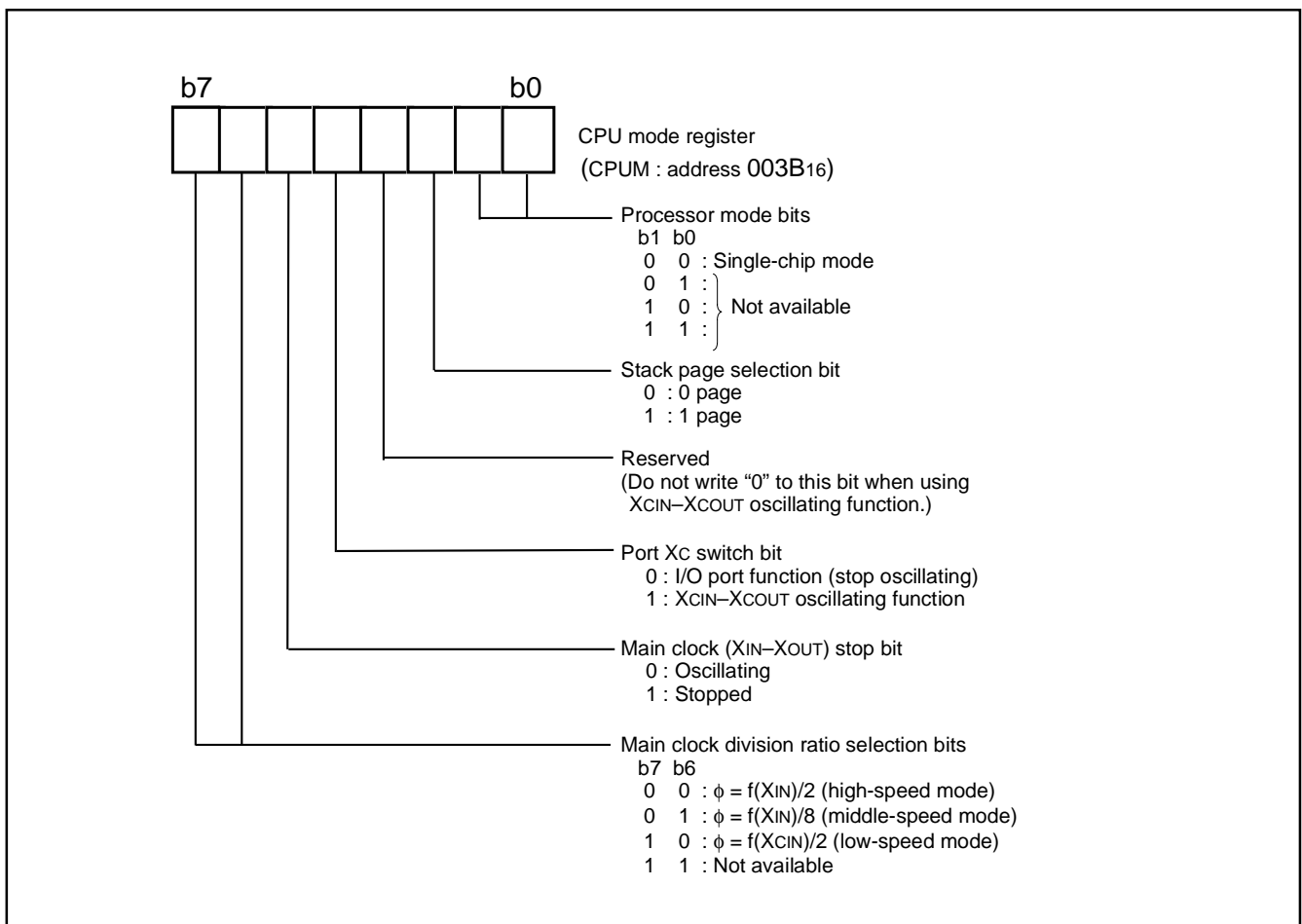

Fig.9 Structure of CPU mode register

MISRG

(1) Bit 0 of address 0010₁₆: Oscillation stabilizing time set after STP instruction released bit

When the MCU stops the clock oscillation by the STP instruction and the STP instruction has been released by an external interrupt source, usually, the fixed values of Timer 1 and Prescaler 12 (Timer 1 = 01₁₆, Prescaler 12 = FF₁₆) are automatically reloaded in order for the oscillation to stabilize. The user can inhibit the automatic setting by setting "1" to bit 0 of MISRG (address 0010₁₆). However, by setting this bit to "1", the previous values, set just before the STP instruction was executed, will remain in Timer 1 and Prescaler 12. Therefore, you will need to set an appropriate value to each register, in accordance with the oscillation stabilizing time, before executing the STP instruction.

Figure 10 shows the structure of MISRG.

(2) Bits 1, 2, 3 of address 0010₁₆: Middle-speed Mode Automatic Switch Function

In order to switch the clock mode of an MCU which has a sub-clock, the following procedure is necessary:

set CPU mode register (003B₁₆) --> start main clock oscillation --> wait for oscillation stabilization --> switch to middle-speed mode (or high-speed mode).

However, the 3803/3804 group has the built-in function which automatically switches from low to middle-speed mode either by the SCL/SDA interrupt (only for the 3804 group) or by program.

●Middle-speed mode automatic switch by SCL/SDA Interrupt (only for 3804 group)

The SCL/SDA interrupt source enables an automatic switch when the middle-speed mode automatic switch set bit (bit 1) of MISRG (address 0010₁₆) is set to "1". The conditions for an automatic switch execution depend on the settings of bits 5 and 6 of the I²C start/stop condition control register (address 0016₁₆). Bit 5 is the SCL/SDA interrupt pin polarity selection bit and bit 6 is the SCL/SDA interrupt pin selection bit. The main clock oscillation stabilizing time can also be selected by middle-speed mode automatic switch wait time set bit (bit 2) of the MISRG.

●Middle-speed mode automatic switch by program(for 3804/3803 group)

The middle-speed mode can also be automatically switched by program while operating in low-speed mode. By setting the middle-speed automatic switch start bit (bit 3) of MISRG (address 0010₁₆) to "1" in the condition that the middle-speed mode automatic switch set bit is "1" while operating in low-speed mode, the MCU will automatically switch to middle-speed mode. In this case, the oscillation stabilizing time of the main clock can be selected by the middle-speed automatic switch wait time set bit (bit 2) of MISRG (address 0010₁₆).

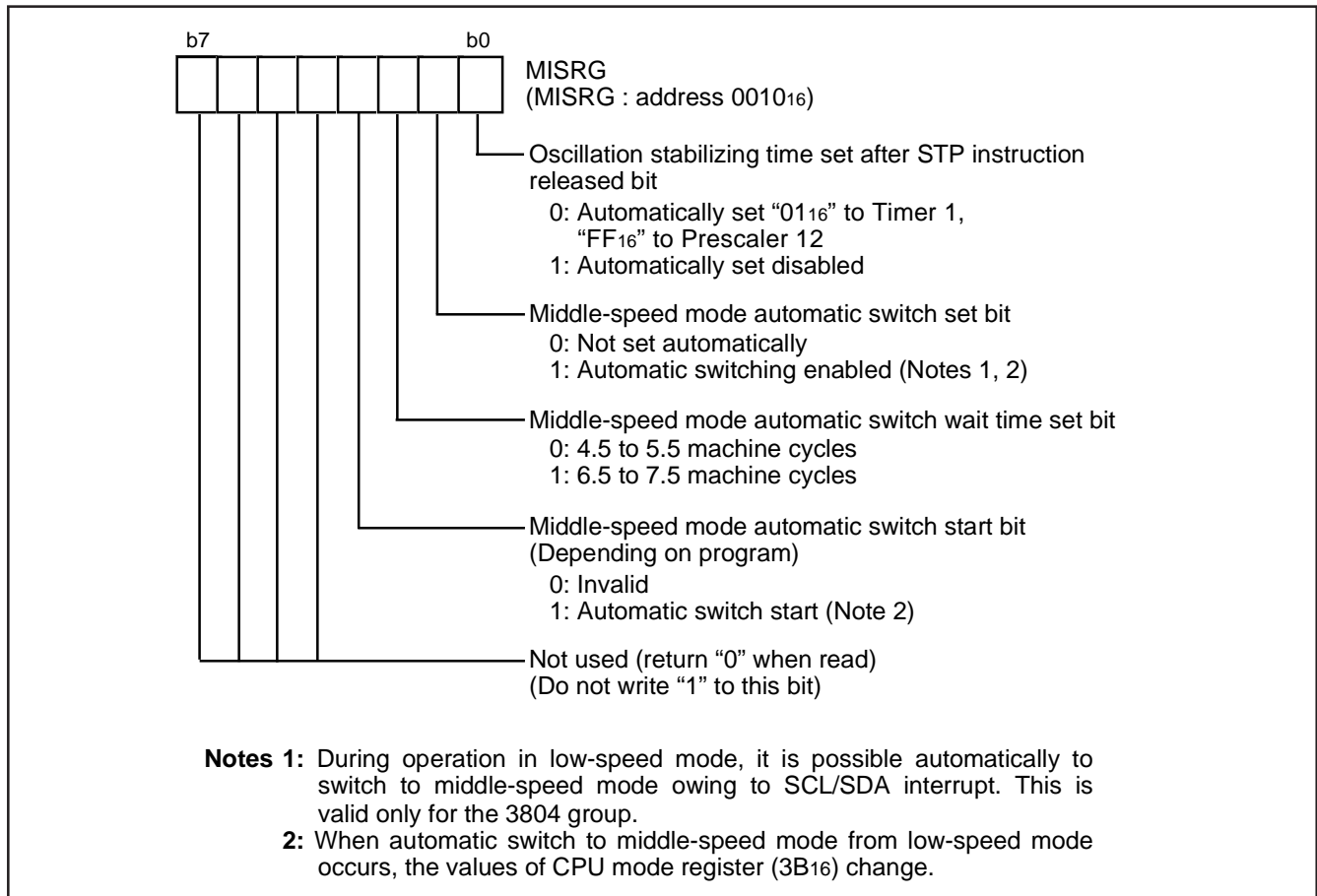

Fig.10 Structure of MISRG

MEMORY

Special Function Register (SFR) Area

The Special Function Register area in the zero page contains control registers such as I/O ports and timers.

RAM

RAM is used for data storage and for stack area of subroutine calls and interrupts.

ROM

The first 128 bytes and the last 2 bytes of ROM are reserved for device testing and the rest is a user area for storing programs.

Interrupt Vector Area

The interrupt vector area contains reset and interrupt vectors.

Zero Page

Access to this area with only 2 bytes is possible in the zero page addressing mode.

Special Page

Access to this area with only 2 bytes is possible in the special page addressing mode.

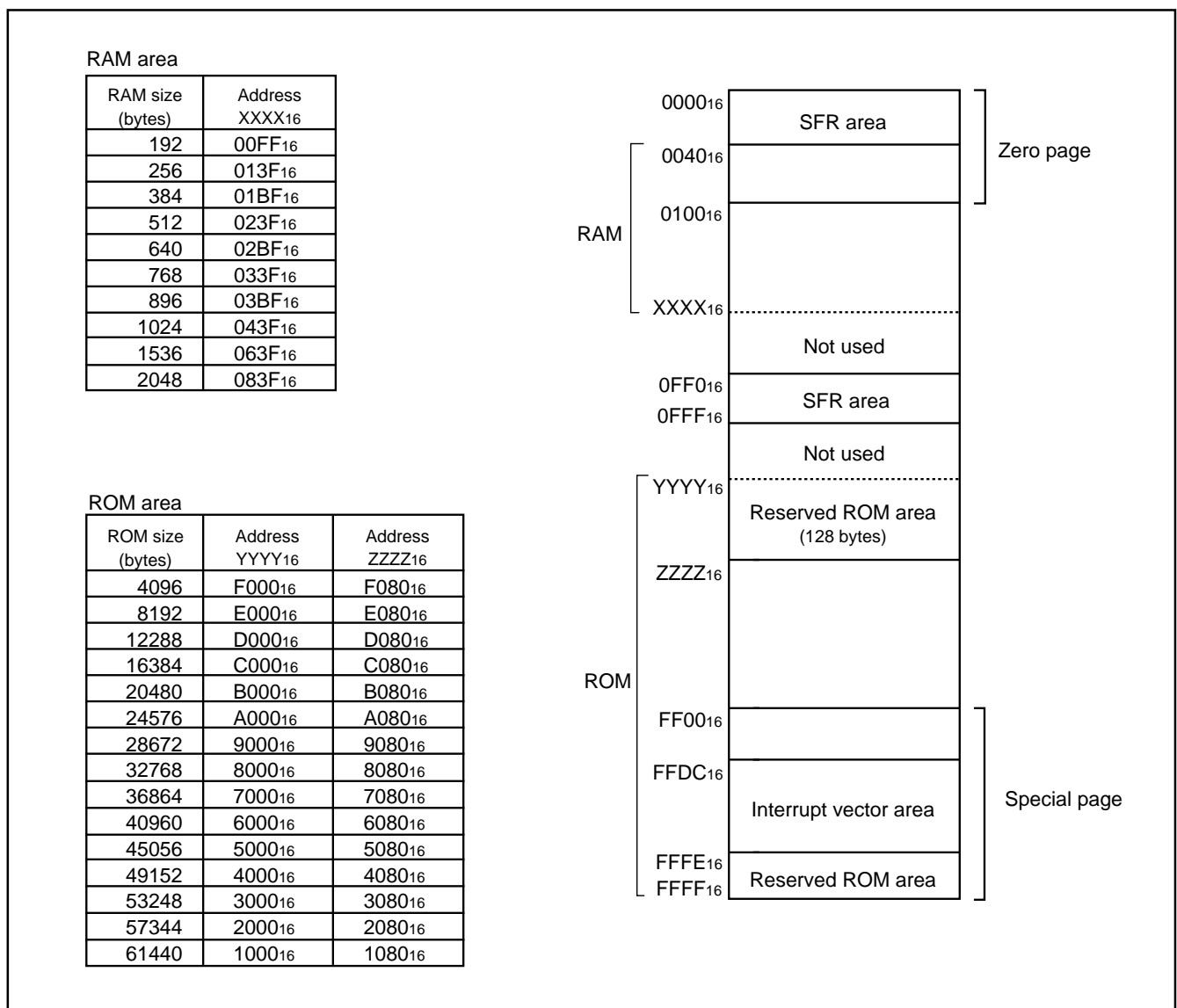

Fig. 11 Memory map diagram

0000 ₁₆	Port P0 (P0)	0020 ₁₆	Prescaler 12 (PRE12)
0001 ₁₆	Port P0 direction register (P0D)	0021 ₁₆	Timer 1 (T1)
0002 ₁₆	Port P1 (P1)	0022 ₁₆	Timer 2 (T2)
0003 ₁₆	Port P1 direction register (P1D)	0023 ₁₆	Timer XY mode register (TM)
0004 ₁₆	Port P2 (P2)	0024 ₁₆	Prescaler X (PREX)
0005 ₁₆	Port P2 direction register (P2D)	0025 ₁₆	Timer X (TX)
0006 ₁₆	Port P3 (P3)	0026 ₁₆	Prescaler Y (PREY)
0007 ₁₆	Port P3 direction register (P3D)	0027 ₁₆	Timer Y (TY)
0008 ₁₆	Port P4 (P4)	0028 ₁₆	Timer Z low-order (TZL)
0009 ₁₆	Port P4 direction register (P4D)	0029 ₁₆	Timer Z high-order (TZH)
000A ₁₆	Port P5 (P5)	002A ₁₆	Timer Z mode register (TZM)
000B ₁₆	Port P5 direction register (P5D)	002B ₁₆	PWM control register (PWMCON)
000C ₁₆	Port P6 (P6)	002C ₁₆	PWM prescaler (PREPWM)
000D ₁₆	Port P6 direction register (P6D)	002D ₁₆	PWM register (PWM)
000E ₁₆	Timer 12, X count source selection register (T12XCSS)	002E ₁₆	
000F ₁₆	Timer Y, Z count source selection register (TYZCSS)	002F ₁₆	Baud rate generator 3 (BRG3)
0010 ₁₆	MISRG	0030 ₁₆	Transmit/Receive buffer register 3 (TB3/RB3)
0011 ₁₆	Reserved *	0031 ₁₆	Serial I/O3 status register (SIO3STS)
0012 ₁₆	Reserved *	0032 ₁₆	Serial I/O3 control register (SIO3CON)
0013 ₁₆	Reserved *	0033 ₁₆	UART3 control register (UART3CON)
0014 ₁₆	Reserved *	0034 ₁₆	AD/DA control register (ADCON)
0015 ₁₆	Reserved *	0035 ₁₆	A-D conversion register 1 (AD1)
0016 ₁₆	Reserved *	0036 ₁₆	D-A1 conversion register (DA1)
0017 ₁₆	Reserved *	0037 ₁₆	D-A2 conversion register (DA2)
0018 ₁₆	Transmit/Receive buffer register 1 (TB1/RB1)	0038 ₁₆	A-D conversion register 2 (AD2)
0019 ₁₆	Serial I/O1 status register (SIO1STS)	0039 ₁₆	Interrupt source selection register (INTSEL)
001A ₁₆	Serial I/O1 control register (SIO1CON)	003A ₁₆	Interrupt edge selection register (INTEDGE)
001B ₁₆	UART1 control register (UART1CON)	003B ₁₆	CPU mode register (CPUM)
001C ₁₆	Baud rate generator (BRG1)	003C ₁₆	Interrupt request register 1 (IREQ1)
001D ₁₆	Serial I/O2 control register (SIO2CON)	003D ₁₆	Interrupt request register 2 (IREQ2)
001E ₁₆	Watchdog timer control register (WDTCON)	003E ₁₆	Interrupt control register 1 (ICON1)
001F ₁₆	Serial I/O2 register (SIO2)	003F ₁₆	Interrupt control register 2 (ICON2)
		0FF0 ₁₆	Port P0 pull-up control register (PULL0)
		0FF1 ₁₆	Port P1 pull-up control register (PULL1)
		0FF2 ₁₆	Port P2 pull-up control register (PULL2)
		0FF3 ₁₆	Port P3 pull-up control register (PULL3)
		0FF4 ₁₆	Port P4 pull-up control register (PULL4)
		0FF5 ₁₆	Port P5 pull-up control register (PULL5)
		0FF6 ₁₆	Port P6 pull-up control register (PULL6)
		0FFE ₁₆	Flash memory control register (FCON)
		0FFF ₁₆	Flash command register (FCMD)

* Reserved area: Do not write any data to this addresses, because these areas are reserved.

Fig. 12 Memory map of 3803 group's special function register (SFR)

0000 ₁₆	Port P0 (P0)	0020 ₁₆	Prescaler 12 (PRE12)
0001 ₁₆	Port P0 direction register (P0D)	0021 ₁₆	Timer 1 (T1)
0002 ₁₆	Port P1 (P1)	0022 ₁₆	Timer 2 (T2)
0003 ₁₆	Port P1 direction register (P1D)	0023 ₁₆	Timer XY mode register (TM)
0004 ₁₆	Port P2 (P2)	0024 ₁₆	Prescaler X (PREX)
0005 ₁₆	Port P2 direction register (P2D)	0025 ₁₆	Timer X (TX)
0006 ₁₆	Port P3 (P3)	0026 ₁₆	Prescaler Y (PREY)
0007 ₁₆	Port P3 direction register (P3D)	0027 ₁₆	Timer Y (TY)
0008 ₁₆	Port P4 (P4)	0028 ₁₆	Timer Z low-order (TZL)
0009 ₁₆	Port P4 direction register (P4D)	0029 ₁₆	Timer Z high-order (TZH)
000A ₁₆	Port P5 (P5)	002A ₁₆	Timer Z mode register (TZM)
000B ₁₆	Port P5 direction register (P5D)	002B ₁₆	PWM control register (PWMCON)
000C ₁₆	Port P6 (P6)	002C ₁₆	PWM prescaler (PREPWM)
000D ₁₆	Port P6 direction register (P6D)	002D ₁₆	PWM register (PWM)
000E ₁₆	Timer 12, X count source selection register (T12XCSS)	002E ₁₆	
000F ₁₆	Timer Y, Z count source selection register (TYZCSS)	002F ₁₆	Baud rate generator 3 (BRG3)
0010 ₁₆	MISRG	0030 ₁₆	Transmit/Receive buffer register 3 (TB3/RB3)
0011 ₁₆	I ² C data shift register (S0)	0031 ₁₆	Serial I/O3 status register (SIO3STS)
0012 ₁₆	I ² C special mode status register (S3)	0032 ₁₆	Serial I/O3 control register (SIO3CON)
0013 ₁₆	I ² C status register (S1)	0033 ₁₆	UART3 control register (UART3CON)
0014 ₁₆	I ² C control register (S1D)	0034 ₁₆	AD/DA control register (ADCON)
0015 ₁₆	I ² C clock control register (S2)	0035 ₁₆	A-D conversion register 1 (AD1)
0016 ₁₆	I ² C START/STOP condition control register (S2D)	0036 ₁₆	D-A1 conversion register (DA1)
0017 ₁₆	I ² C special mode control register (S3D)	0037 ₁₆	D-A2 conversion register (DA2)
0018 ₁₆	Transmit/Receive buffer register 1 (TB1/RB1)	0038 ₁₆	A-D conversion register 2 (AD2)
0019 ₁₆	Serial I/O1 status register (SIO1STS)	0039 ₁₆	Interrupt source selection register (INTSEL)
001A ₁₆	Serial I/O1 control register (SIO1CON)	003A ₁₆	Interrupt edge selection register (INTEDGE)
001B ₁₆	UART1 control register (UART1CON)	003B ₁₆	CPU mode register (CPUM)
001C ₁₆	Baud rate generator (BRG1)	003C ₁₆	Interrupt request register 1 (IREQ1)
001D ₁₆	Serial I/O2 control register (SIO2CON)	003D ₁₆	Interrupt request register 2 (IREQ2)
001E ₁₆	Watchdog timer control register (WDTCON)	003E ₁₆	Interrupt control register 1 (ICON1)
001F ₁₆	Serial I/O2 register (SIO2)	003F ₁₆	Interrupt control register 2 (ICON2)
		0FF0 ₁₆	Port P0 pull-up control register (PULL0)
		0FF1 ₁₆	Port P1 pull-up control register (PULL1)
		0FF2 ₁₆	Port P2 pull-up control register (PULL2)
		0FF3 ₁₆	Port P3 pull-up control register (PULL3)
		0FF4 ₁₆	Port P4 pull-up control register (PULL4)
		0FF5 ₁₆	Port P5 pull-up control register (PULL5)
		0FF6 ₁₆	Port P6 pull-up control register (PULL6)
		0FF7 ₁₆	I ² C slave address register 0 (S0D0)
		0FF8 ₁₆	I ² C slave address register 1 (S0D1)
		0FF9 ₁₆	I ² C slave address register 2 (S0D2)
		0FFE ₁₆	Flash memory control register (FCON)
		0FFF ₁₆	Flash command register (FCMD)

Fig. 13 Memory map of 3804 group's special function register (SFR)

I/O PORTS

The I/O ports have direction registers which determine the input/output direction of each individual pin. Each bit in a direction register corresponds to one pin, and each pin can be set to be input port or output port. When "0" is written to the bit corresponding to a pin, that pin be-

comes an input pin. When "1" is written to that bit, that pin becomes an output pin. If data is read from a pin which is set to output, the value of the port output latch is read, not the value of the pin itself. Pins set to input are floating. If a pin set to input is written to, only the port output latch is written to and the pin remains floating.

Table 4 I/O port function of 3803 group

Pin	Name	I/O Structure	Non-Port Function	Related SFRs	Ref.No.	
P00/AN8-P07/AN15	Port P0	CMOS compatible input level	A-D converter input	AD/DA control register	(1)	
P10/INT41 P11/INT01	Port P1	CMOS 3-state output	External interrupt input	Interrupt edge selection register	(2)	
P12-P17					(3)	
P20/LED0-P27/LED7			Port P2			
P30/DA1 P31/DA2	Port P3	CMOS compatible input level	D-A converter output	AD/DA control register	(4)	
P32 P33		CMOS compatible input level			(5)	
P34/RxD3 P35/TxD3 P36/SCLK3 P37/SRDY3		N-channel open-drain output	Serial I/O3 function I/O	Serial I/O3 control register UART3 control register	(6) (7) (8) (9)	
		CMOS compatible input level				
P40/INT00/XCIN P41/INT40/XCOUT	Port P4	CMOS compatible input level	External interrupt input	Interrupt edge selection register	(10)	
P42/INT1 P43/INT2			Sub-clock generating circuit	CPU mode register	(11)	
P44/RxD1 P45/TxD1 P46/SCLK1			External interrupt input	Interrupt edge selection register	(2)	
P47/SRDY1/CNTR2			Serial I/O1 function I/O	Serial I/O1 control register UART1 control register	(6) (7) (8)	
		CMOS 3-state output	Serial I/O1 function I/O	Serial I/O1 control register	(12)	
			Timer Z function I/O	Timer Z mode register		
P50/SIN2 P51/SOUT2 P52/SCLK2 P53/SRDY2	Port P5	CMOS compatible input level	Serial I/O2 function I/O	Serial I/O2 control register	(13)	
						(14)
						(15)
						(16)
P54/CNTR0 P55/CNTR1			Timer X, Y function I/O	Timer XY mode register	(17)	
P56/PWM	PWM output	PWM control register	(18)			
P57/INT3	External interrupt input	Interrupt edge selection register	(2)			
P60/AN0-P67/AN7	Port P6	CMOS compatible input level	A-D converter input	AD/DA control register	(1)	
		CMOS 3-state output				

Notes 1: Refer to the applicable sections how to use double-function ports as function I/O ports, .

2: Make sure that the input level at each pin is either 0 V or Vcc during execution of the STP instruction.

When an input level is at an intermediate potential, a current will flow from Vcc to Vss through the input-stage gate.

Table 5 I/O port function of 3804 group

Pin	Name	I/O Structure	Non-Port Function	Related SFRs	Ref.No.
P00/AN8–P07/AN15	Port P0	CMOS compatible input level	A-D converter input	AD/DA control register	(1)
P10/INT41 P11/INT01	Port P1	CMOS 3-state output	External interrupt input	Interrupt edge selection register	(2)
P12–P17					(3)
P20/LED0– P27/LED7	Port P2				
P30/DA1 P31/DA2	Port P3	CMOS compatible input level CMOS 3-state output	D-A converter output	AD/DA control register	(4)
P32/SDA P33/SCL		CMOS compatible input level N-channel open-drain output CMOS/SMBUS input level (when selecting I ² C-BUS interface function)	I ² C-BUS interface function I/O	I ² C control register	(5)
P34/RxD3 P35/TxD3 P36/SCLK3 P37/SRDY3		CMOS compatible input level CMOS 3-state output	Serial I/O3 function I/O	Serial I/O3 control register UART3 control register	(6) (7) (8) (9)
P40/INT00/XCIN P41/INT40/XCOUT	Port P4	CMOS compatible input level CMOS 3-state output	External interrupt input Sub-clock generating circuit	Interrupt edge selection register CPU mode register	(10) (11)
P42/INT1 P43/INT2			External interrupt input	Interrupt edge selection register	(2)
P44/RxD1 P45/TxD1 P46/SCLK1			Serial I/O1 function I/O	Serial I/O1 control register UART1 control register	(6) (7) (8)
P47/SRDY1/CNTR2			Serial I/O1 function I/O Timer Z function I/O	Serial I/O1 control register Timer Z mode register	(12)
P50/SIN2 P51/SOUT2 P52/SCLK2 P53/SRDY2	Port P5	CMOS compatible input level CMOS 3-state output	Serial I/O2 function I/O	Serial I/O2 control register	(13) (14) (15) (16)
P54/CNTR0 P55/CNTR1			Timer X, Y function I/O	Timer XY mode register	(17)
P56/PWM			PWM output	PWM control register	(18)
P57/INT3			External interrupt input	Interrupt edge selection register	(2)
P60/AN0–P67/AN7	Port P6	CMOS compatible input level CMOS 3-state output	A-D converter input	AD/DA control register	(1)

Notes 1: Refer to the applicable sections how to use double-function ports as function I/O ports, .

2: Make sure that the input level at each pin is either 0 V or V_{CC} during execution of the STP instruction.

When an input level is at an intermediate potential, a current will flow from V_{CC} to V_{SS} through the input-stage gate.

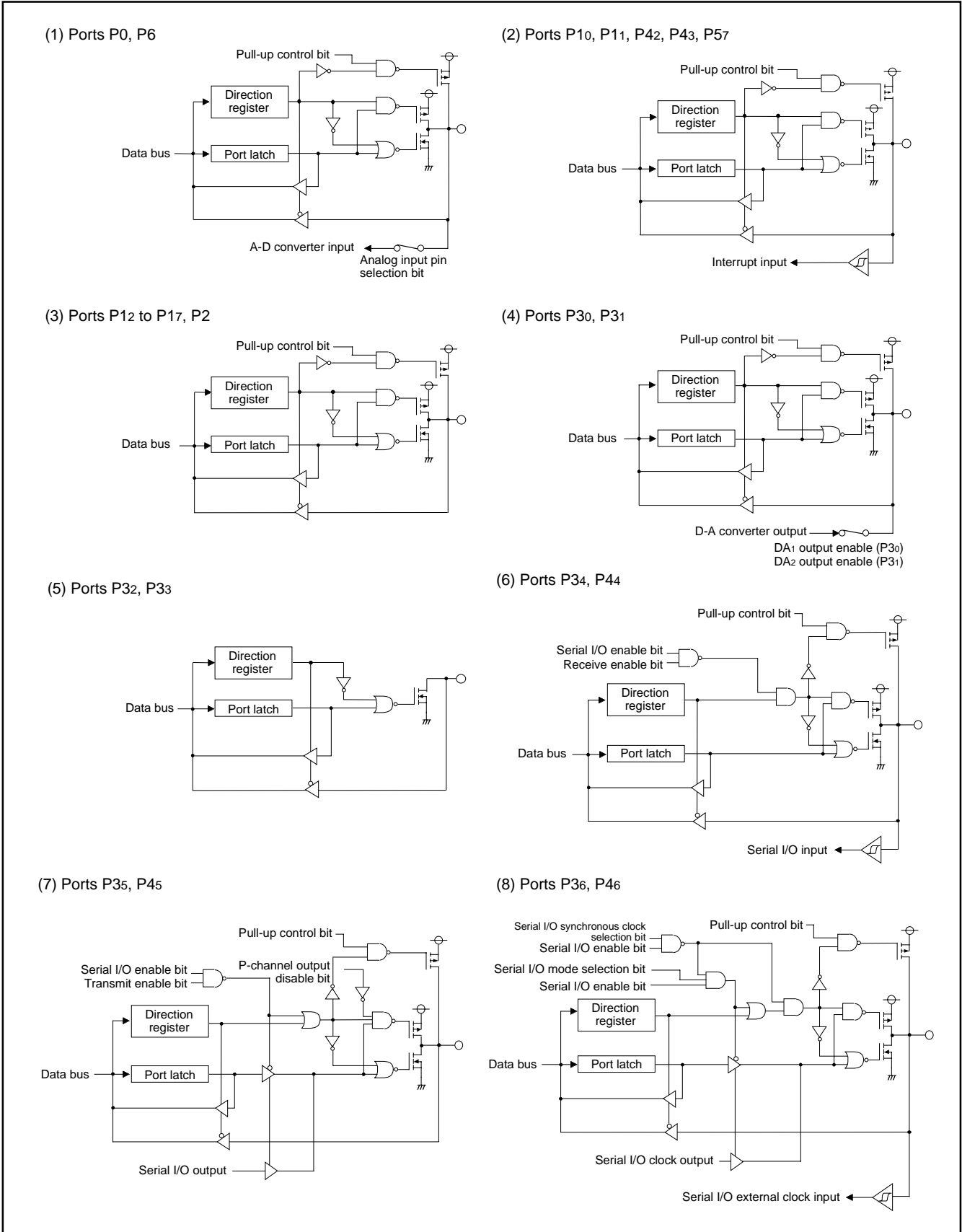

Fig. 14 Port block diagram of 3803 group (1)

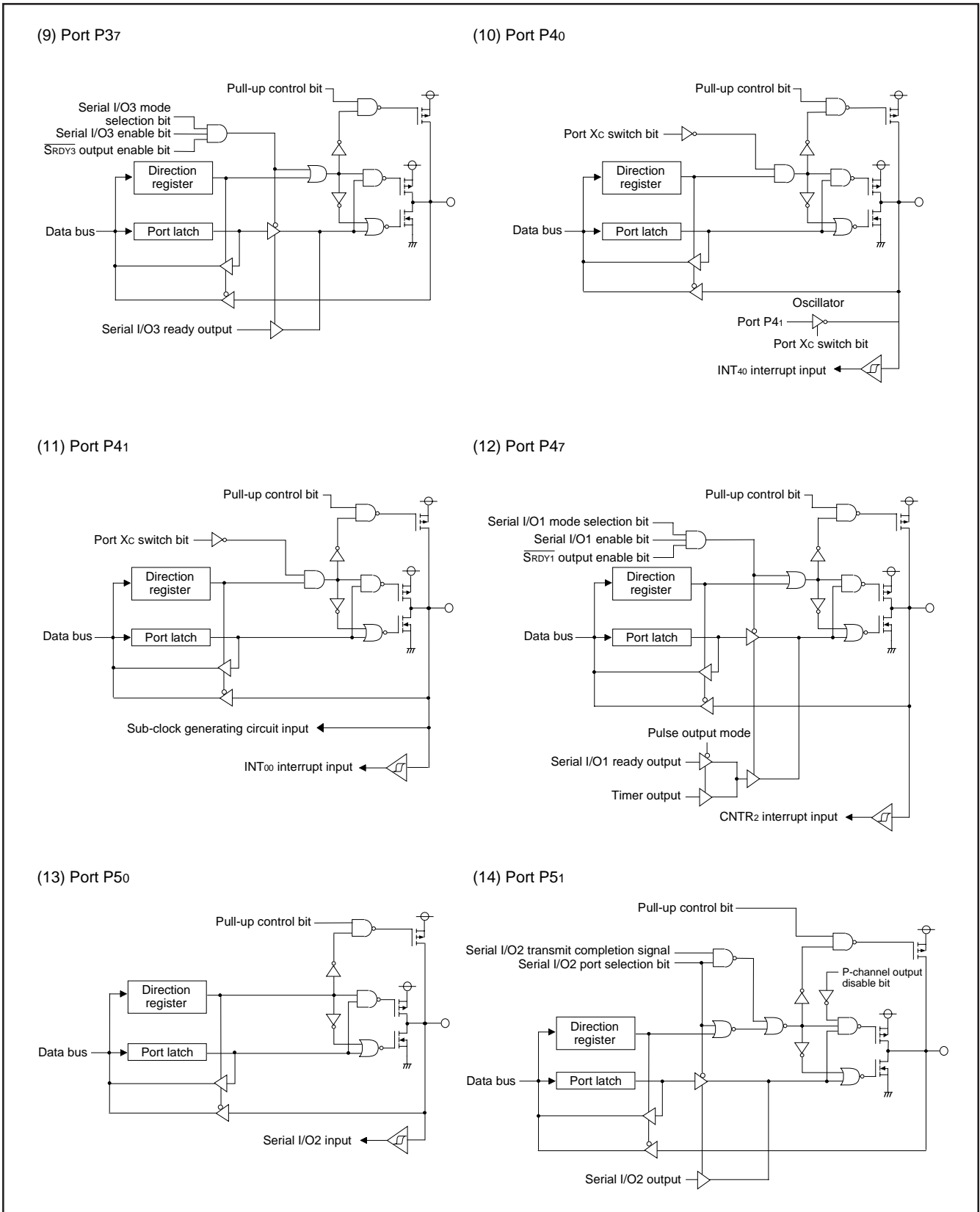

Fig. 15 Port block diagram of 3803 group (2)

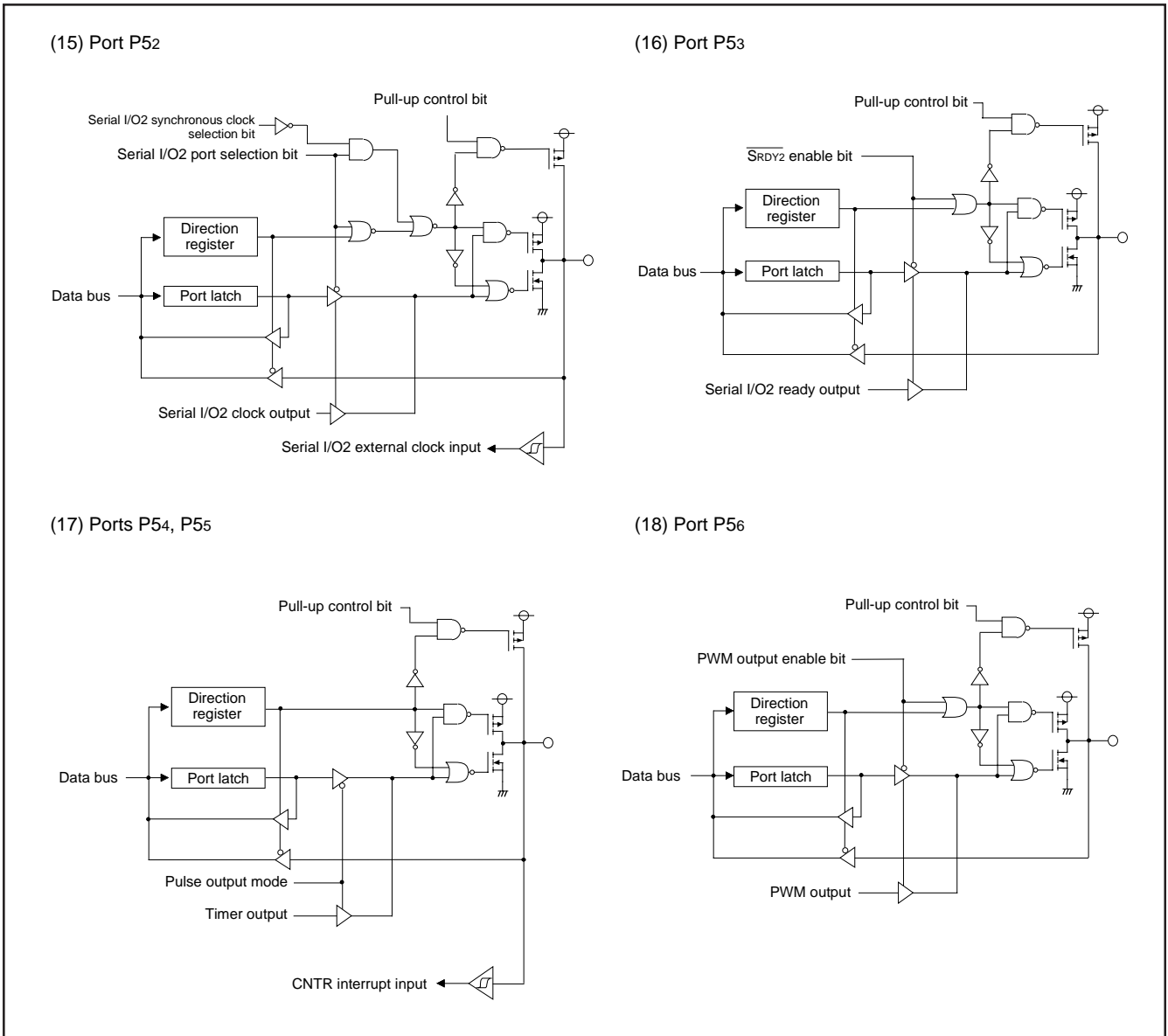

Fig. 16 Port block diagram of 3803 group (3)

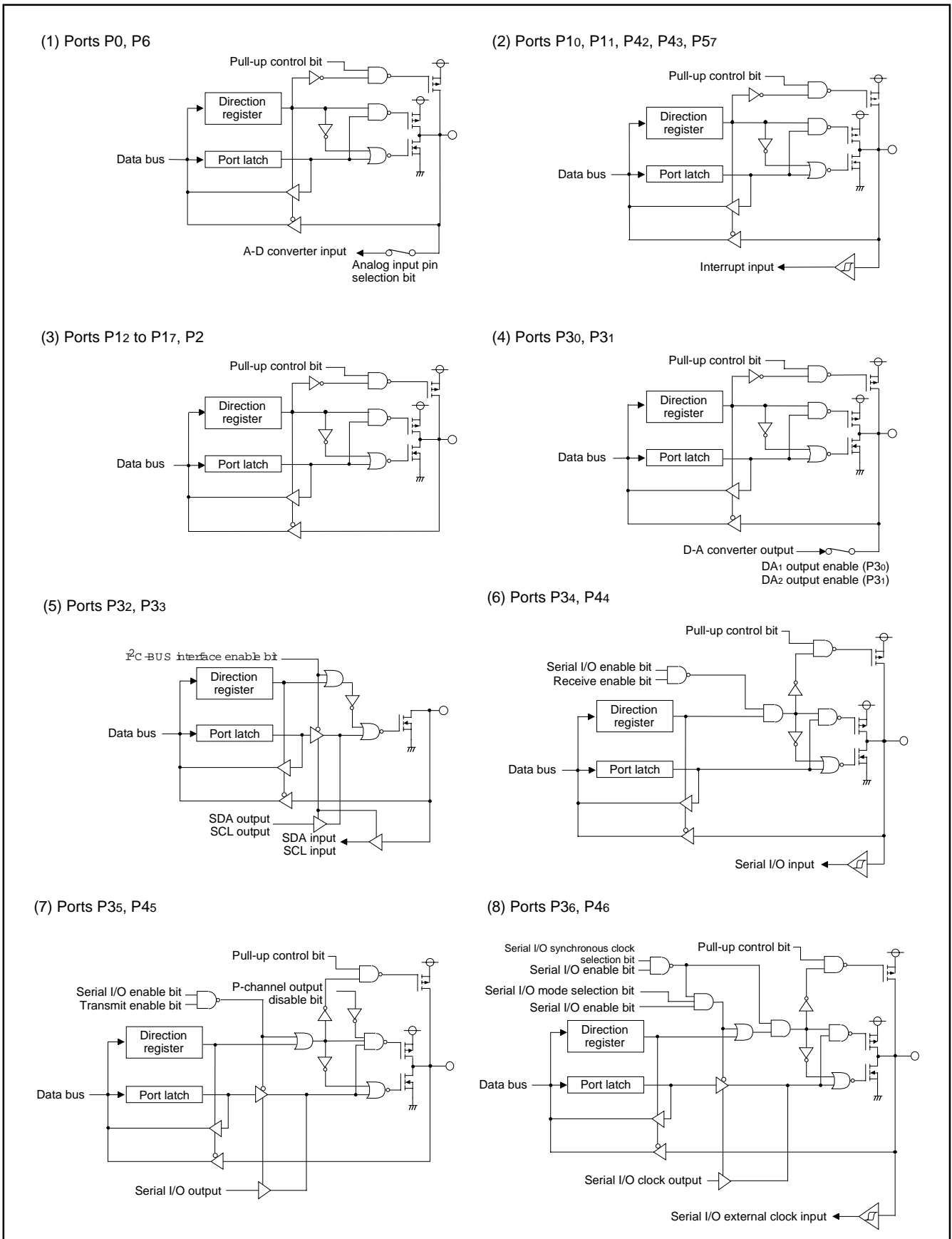

Fig. 17 Port block diagram of 3804 group (1)

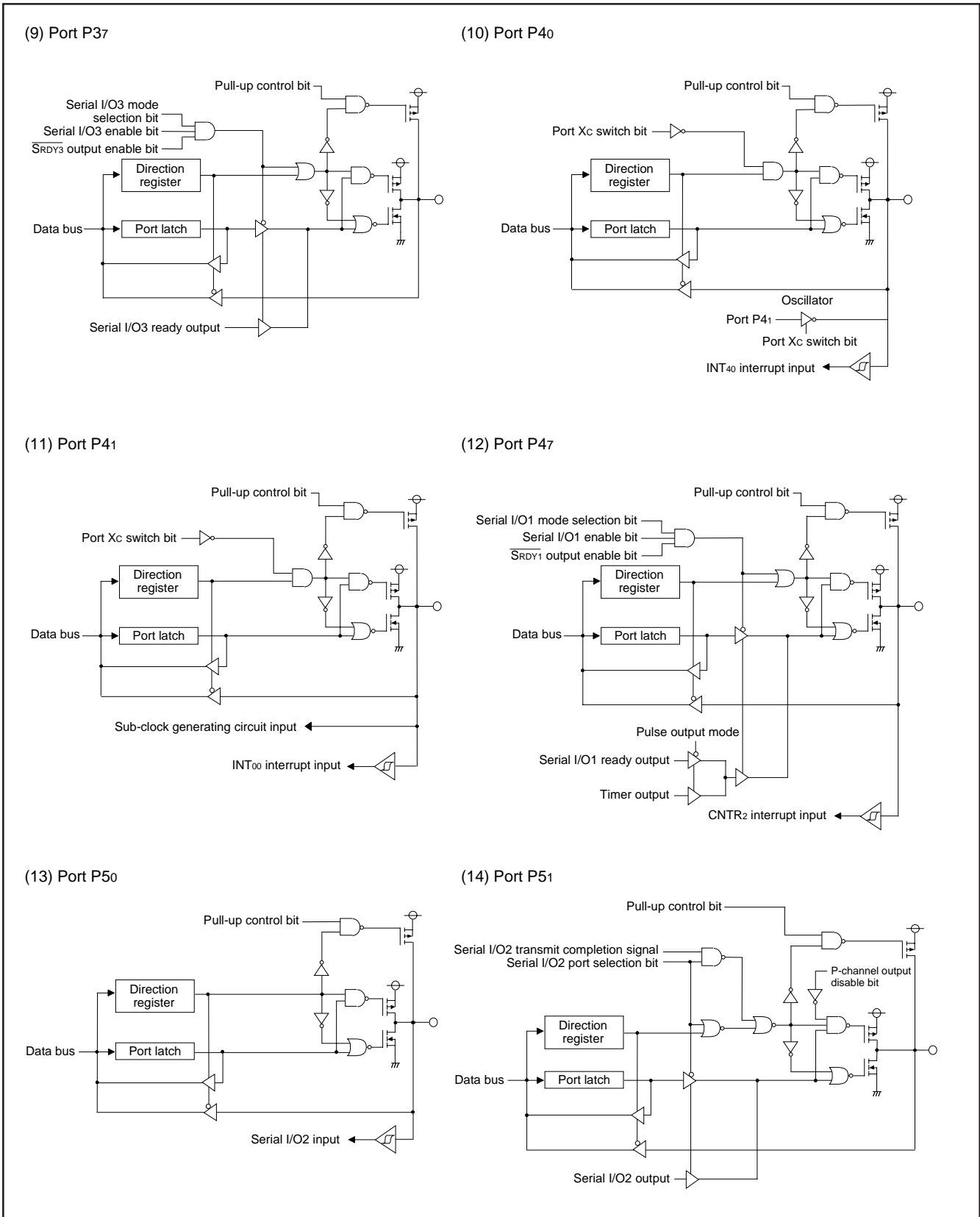

Fig. 18 Port block diagram of 3804 group (2)

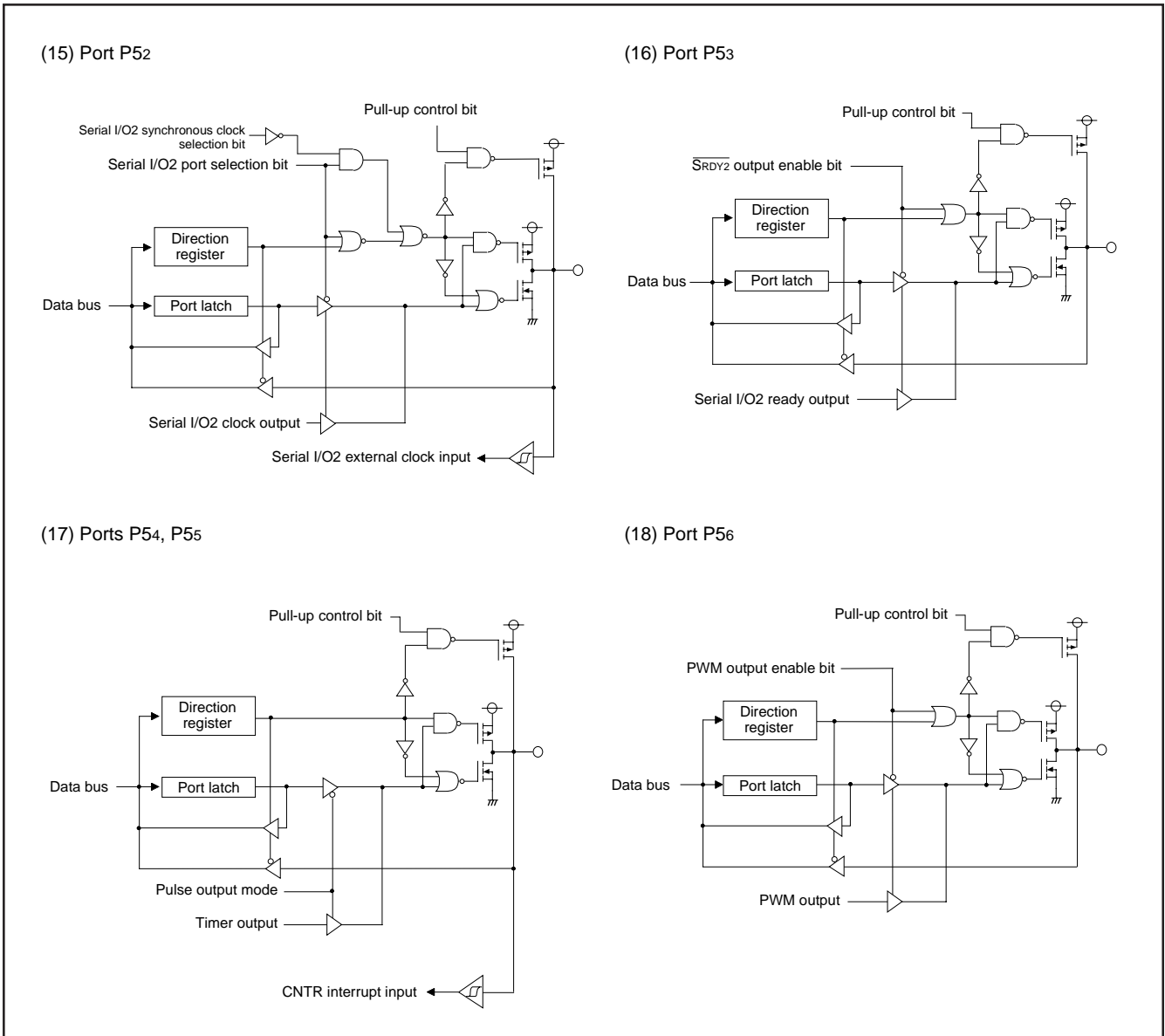

Fig. 19 Port block diagram of 3804 group (3)

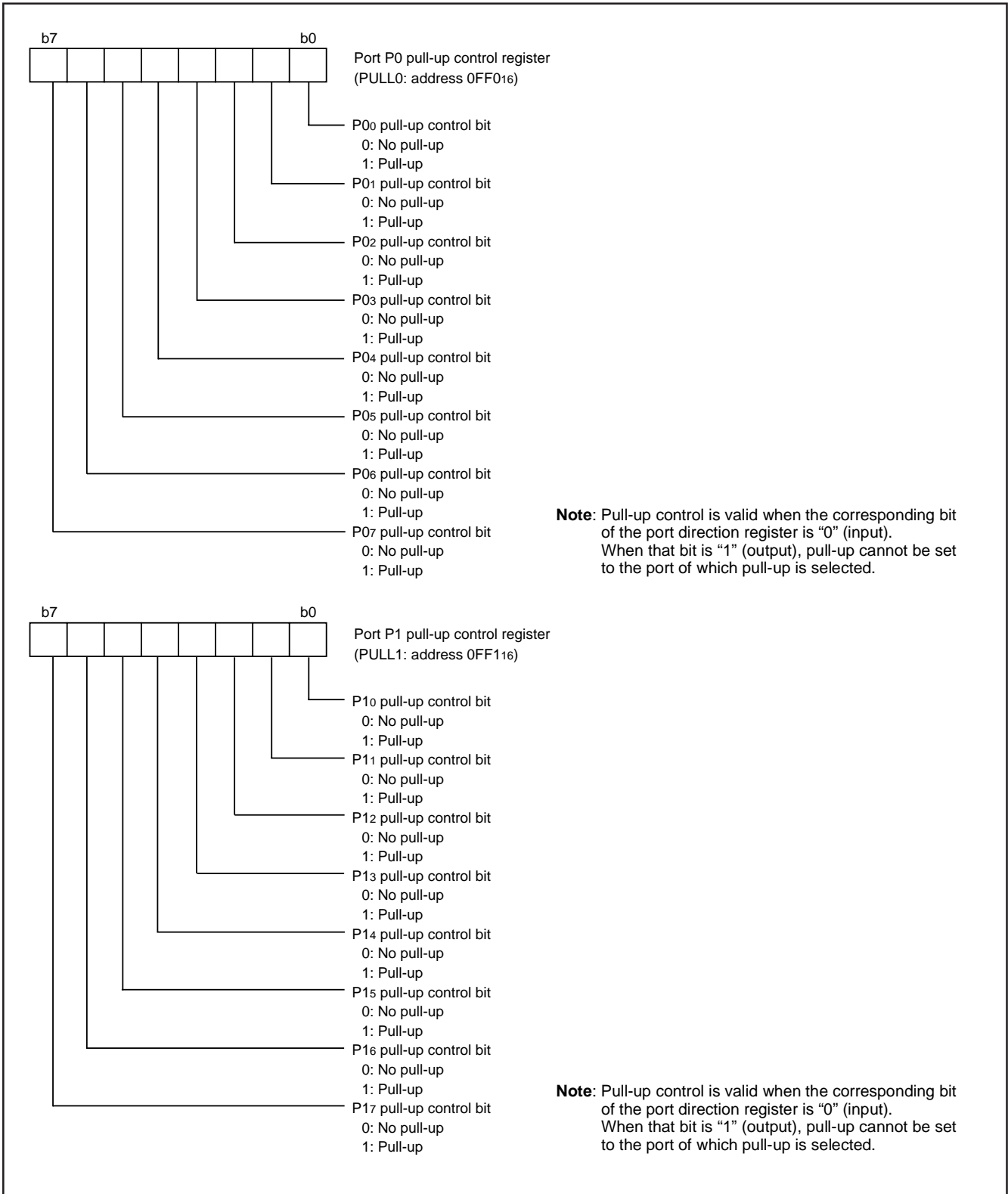

Fig. 20 Structure of port pull-up control register (1)

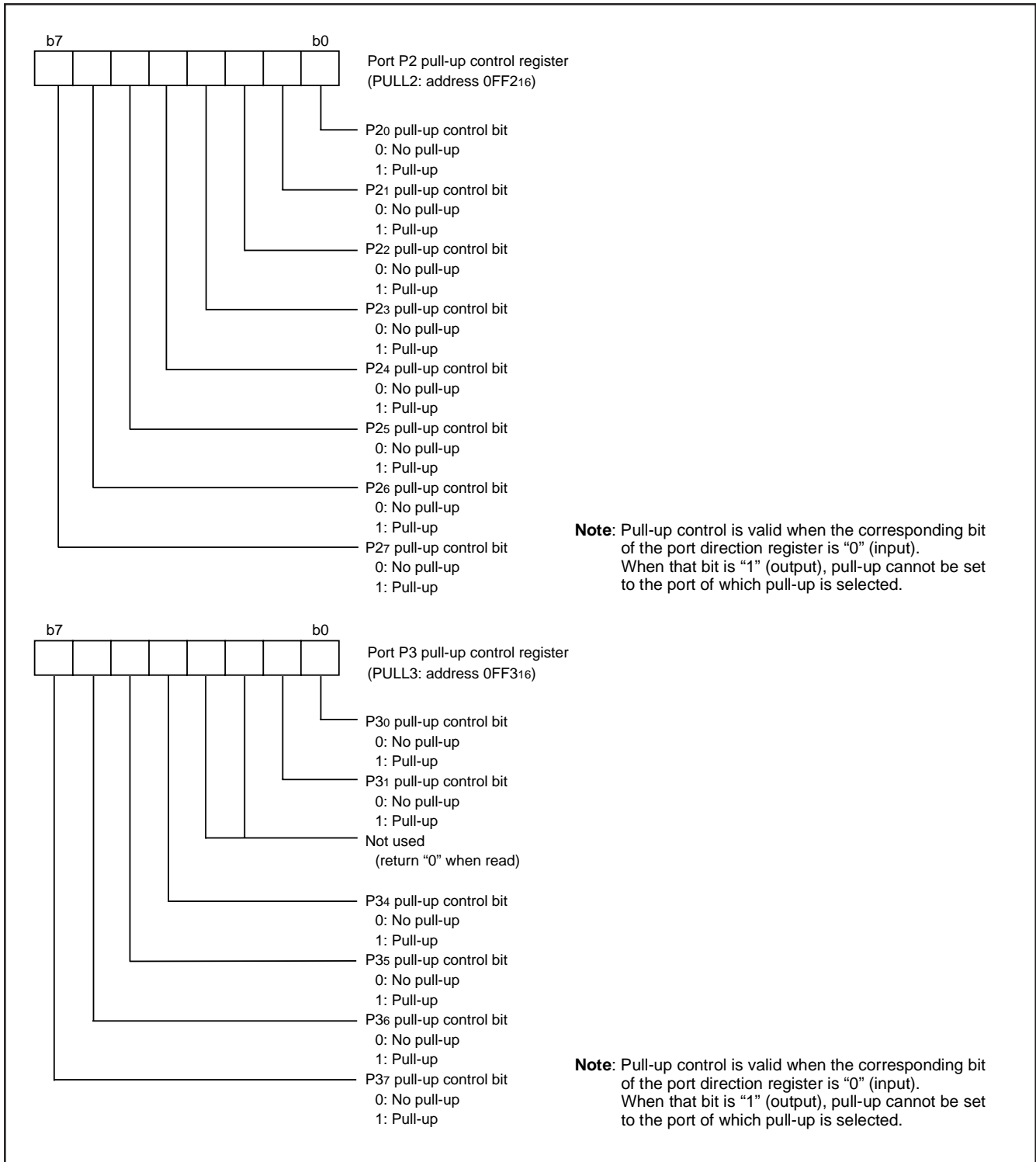

Fig. 21 Structure of port pull-up control register (2)

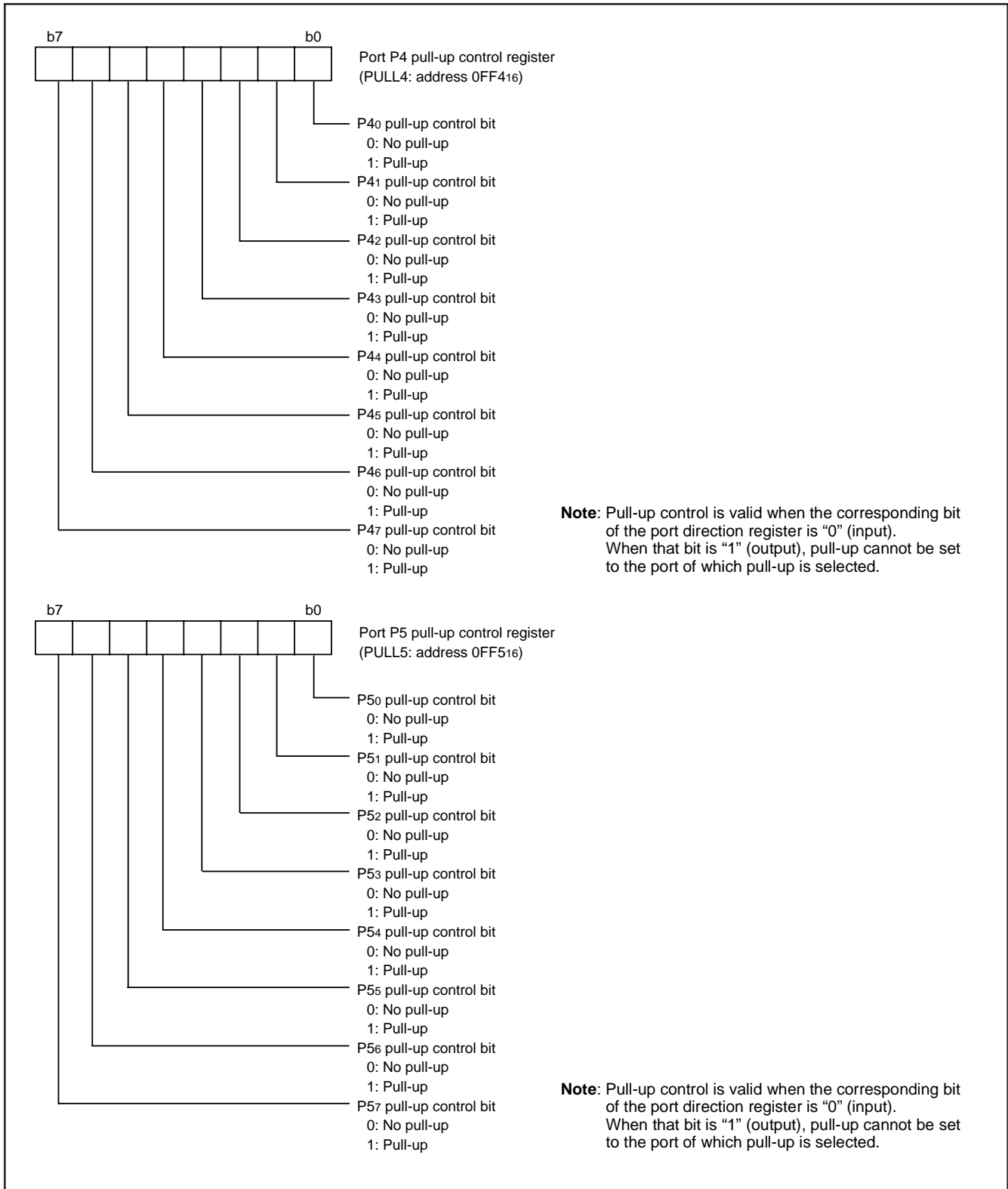

Fig. 22 Structure of port pull-up control register (3)

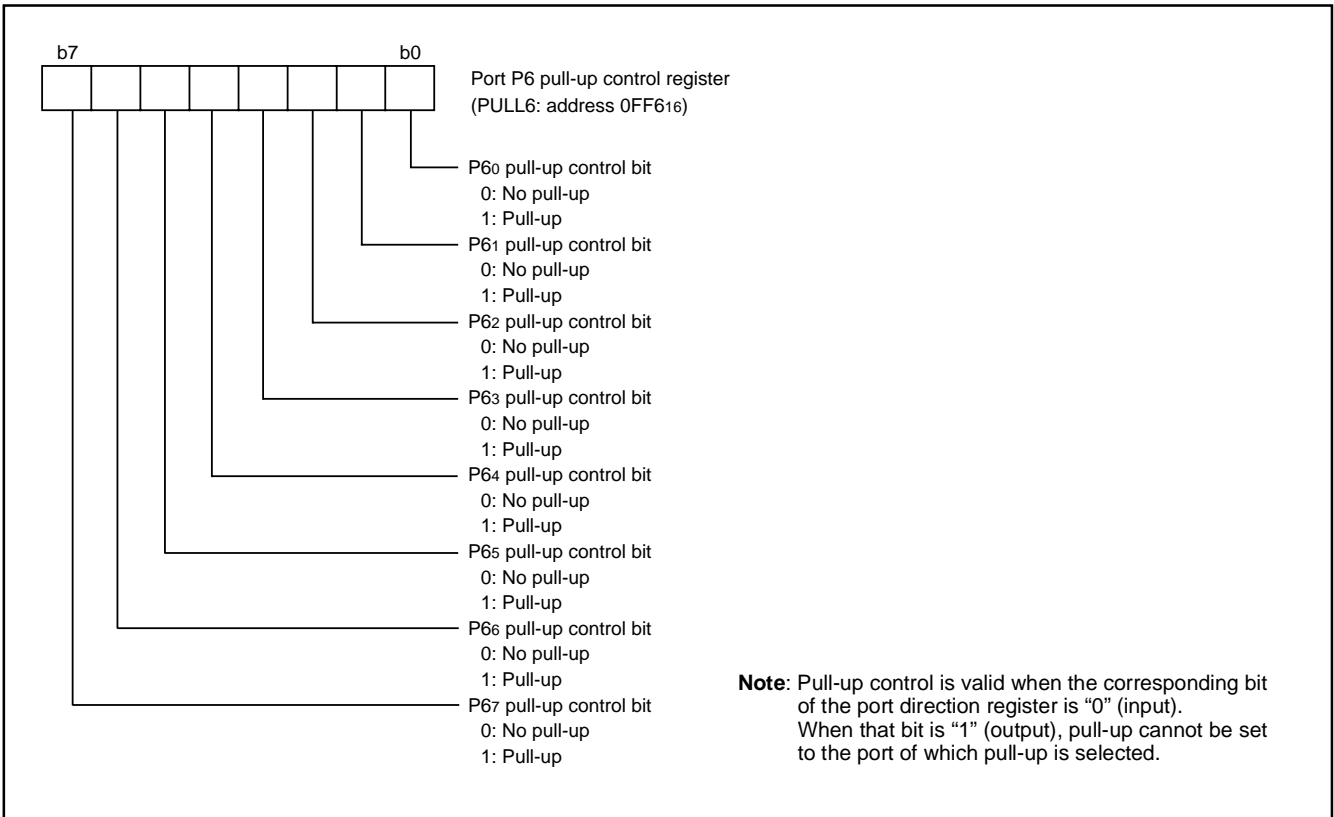

Fig. 23 Structure of port pull-up control register (4)

INTERRUPTS

The 3803 group's interrupts are a type of vector and occur by 16 sources among 21 sources: eight external, twelve internal, and one software.

The 3804 group's interrupts occur by 16 sources among 23 sources: nine external, thirteen internal, and one software.

Interrupt Control

Each interrupt is controlled by an interrupt request bit, an interrupt enable bit, and the interrupt disable flag except for the software interrupt set by the BRK instruction. An interrupt occurs if the corresponding interrupt request and enable bits are "1" and the interrupt disable flag is "0".

Interrupt enable bits can be set or cleared by software.

Interrupt request bits can be cleared by software, but cannot be set by software.

The reset and the BRK instruction cannot be disabled with any flag or bit. The I (interrupt disable) flag disables all interrupts except the reset and the BRK instruction interrupt.

When several interrupt requests occur at the same time, the interrupts are received according to priority.

Interrupt Operation

By acceptance of an interrupt, the following operations are automatically performed:

1. The contents of the program counter and the processor status register are automatically pushed onto the stack.
2. The interrupt disable flag is set and the corresponding interrupt request bit is cleared.
3. The interrupt jump destination address is read from the vector table into the program counter.

Interrupt Source Selection

Which of each combination of the following interrupt sources can be selected by the interrupt source selection register (address 003916).

1. INT₀ or Timer Z
2. Serial I/O1 transmission or SCL, SDA (for 3804 group)
3. CNTR₀ or SCL, SDA (for 3804 group)
4. CNTR₁ or Serial I/O3 reception (for 3804 group)
5. Serial I/O2 or Timer Z
6. INT₂ or I²C
7. INT₄ or CNTR₂
8. A-D converter or serial I/O3 transmission

External Interrupt Pin Selection

The occurrence sources of the external interrupt INT₀ and INT₄ can be selected from either input from INT₀₀ and INT₄₀ pin, or input from INT₀₁ and INT₄₁ pin by the INT₀, INT₄ interrupt switch bit of interrupt edge selection register (bit 6 of address 003A16).

■ Notes

When setting of the following register or bit is changed, the interrupt request bit may be set to "1."

- Interrupt edge selection register (address 003A16)
- Interrupt source selection register (address 003916)

Accept the interrupt after clearing the interrupt request bit to "0" after interrupt is disabled and the above register or bit is set.

Table 6 Interrupt vector addresses and priority of 3803 group

Interrupt Source	Priority	Vector Addresses (Note 1)		Interrupt Request Generating Conditions	Remarks
		High	Low		
Reset (Note 2)	1	FFFD ₁₆	FFFC ₁₆	At reset	Non-maskable
INT ₀	2	FFFB ₁₆	FFFA ₁₆	At detection of either rising or falling edge of INT ₀ input	External interrupt (active edge selectable)
Timer Z				At timer Z underflow	
INT ₁	3	FFF9 ₁₆	FFF8 ₁₆	At detection of either rising or falling edge of INT ₁ input	External interrupt (active edge selectable)
Serial I/O ₁ reception	4	FFF7 ₁₆	FFF6 ₁₆	At completion of serial I/O ₁ data reception	Valid when serial I/O ₁ is selected
Serial I/O ₁ transmission	5	FFF5 ₁₆	FFF4 ₁₆	At completion of serial I/O ₁ transmission shift or when transmission buffer is empty	Valid when serial I/O ₁ is selected
Timer X	6	FFF3 ₁₆	FFF2 ₁₆	At timer X underflow	
Timer Y	7	FFF1 ₁₆	FFF0 ₁₆	At timer Y underflow	
Timer 1	8	FFEF ₁₆	FFEE ₁₆	At timer 1 underflow	STP release timer underflow
Timer 2	9	FFED ₁₆	FFEC ₁₆	At timer 2 underflow	
CNTR ₀	10	FFEB ₁₆	FFEA ₁₆	At detection of either rising or falling edge of CNTR ₀ input	External interrupt (active edge selectable)
CNTR ₁				At detection of either rising or falling edge of CNTR ₁ input	External interrupt (active edge selectable)
Serial I/O ₃ reception	11	FFE9 ₁₆	FFE8 ₁₆	At completion of serial I/O ₃ data reception	Valid when serial I/O ₃ is selected
Serial I/O ₂				At completion of serial I/O ₂ data transmission or reception	Valid when serial I/O ₂ is selected
Timer Z	12	FFE7 ₁₆	FFE6 ₁₆	At timer Z underflow	
INT ₂				At detection of either rising or falling edge of INT ₂ input	External interrupt (active edge selectable)
INT ₃	13	FFE5 ₁₆	FFE4 ₁₆	At detection of either rising or falling edge of INT ₃ input	External interrupt (active edge selectable)
INT ₄				At detection of either rising or falling edge of INT ₄ input	External interrupt (active edge selectable)
CNTR ₂	14	FFE3 ₁₆	FFE2 ₁₆	At detection of either rising or falling edge of CNTR ₂ input	External interrupt (active edge selectable)
A-D converter				At completion of A-D conversion	
Serial I/O ₃ transmission	15	FFE1 ₁₆	FFE0 ₁₆	At completion of serial I/O ₃ transmission shift or when transmission buffer is empty	Valid when serial I/O ₃ is selected
BRK instruction				At BRK instruction execution	Non-maskable software interrupt

Notes 1: Vector addresses contain interrupt jump destination addresses.

2: Reset function in the same way as an interrupt with the highest priority.

Table 7 Interrupt vector addresses and priority of 3804 group

Interrupt Source	Priority	Vector Addresses (Note 1)		Interrupt Request Generating Conditions	Remarks
		High	Low		
Reset (Note 2)	1	FFFD ₁₆	FFFC ₁₆	At reset	Non-maskable
INT ₀	2	FFFB ₁₆	FFFA ₁₆	At detection of either rising or falling edge of INT ₀ input	External interrupt (active edge selectable)
Timer Z				At timer Z underflow	
INT ₁	3	FFF9 ₁₆	FFF8 ₁₆	At detection of either rising or falling edge of INT ₁ input	External interrupt (active edge selectable)
Serial I/O1 reception	4	FFF7 ₁₆	FFF6 ₁₆	At completion of serial I/O1 data reception	Valid when serial I/O1 is selected
Serial I/O1 transmission	5	FFF5 ₁₆	FFF4 ₁₆	At completion of serial I/O1 transmission shift or when transmission buffer is empty	Valid when serial I/O1 is selected
SCL, SDA				At detection of either rising or falling edge of SCL or SDA	External interrupt (active edge selectable)
Timer X	6	FFF3 ₁₆	FFF2 ₁₆	At timer X underflow	
Timer Y	7	FFF1 ₁₆	FFF0 ₁₆	At timer Y underflow	
Timer 1	8	FFEF ₁₆	FFEE ₁₆	At timer 1 underflow	STP release timer underflow
Timer 2	9	FFED ₁₆	FFEC ₁₆	At timer 2 underflow	
CNTR ₀	10	FFEB ₁₆	FFEA ₁₆	At detection of either rising or falling edge of CNTR ₀ input	External interrupt (active edge selectable)
SCL, SDA				At detection of either rising or falling edge of SCL or SDA	External interrupt (active edge selectable)
CNTR ₁	11	FFE9 ₁₆	FFE8 ₁₆	At detection of either rising or falling edge of CNTR ₁ input	External interrupt (active edge selectable)
Serial I/O3 reception				At completion of serial I/O3 data reception	Valid when serial I/O3 is selected
Serial I/O2	12	FFE7 ₁₆	FFE6 ₁₆	At completion of serial I/O2 data transmission or reception	Valid when serial I/O2 is selected
Timer Z				At timer Z underflow	
INT ₂	13	FFE5 ₁₆	FFE4 ₁₆	At detection of either rising or falling edge of INT ₂ input	External interrupt (active edge selectable)
I ² C				At completion of data transfer	
INT ₃	14	FFE3 ₁₆	FFE2 ₁₆	At detection of either rising or falling edge of INT ₃ input	External interrupt (active edge selectable)
INT ₄	15	FFE1 ₁₆	FFE0 ₁₆	At detection of either rising or falling edge of INT ₄ input	External interrupt (active edge selectable)
CNTR ₂				At detection of either rising or falling edge of CNTR ₂ input	External interrupt (active edge selectable)
A-D converter	16	FFDF ₁₆	FFDE ₁₆	At completion of A-D conversion	
Serial I/O3 transmission				At completion of serial I/O3 transmission shift or when transmission buffer is empty	Valid when serial I/O3 is selected
BRK instruction	17	FFDD ₁₆	FFDC ₁₆	At BRK instruction execution	Non-maskable software interrupt

Notes 1: Vector addresses contain interrupt jump destination addresses.

2: Reset function in the same way as an interrupt with the highest priority.

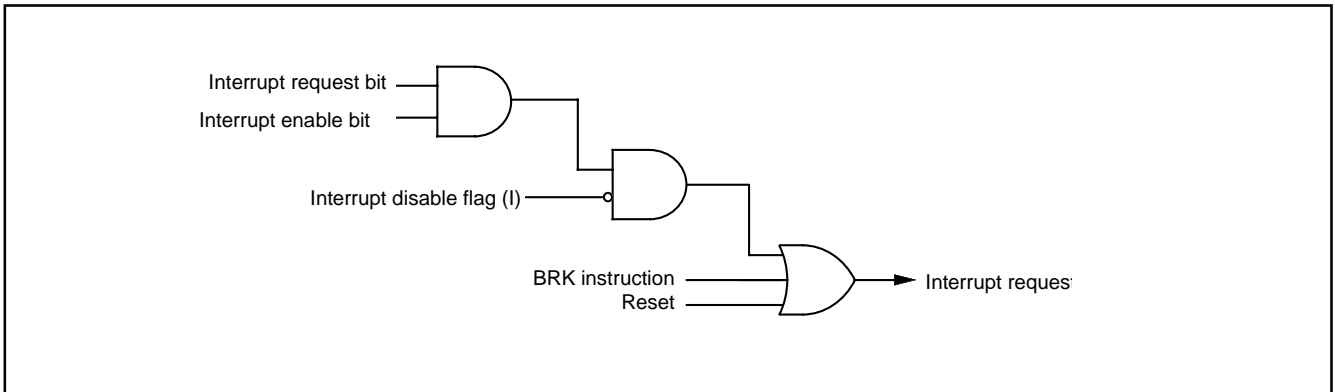

Fig. 24 Interrupt control

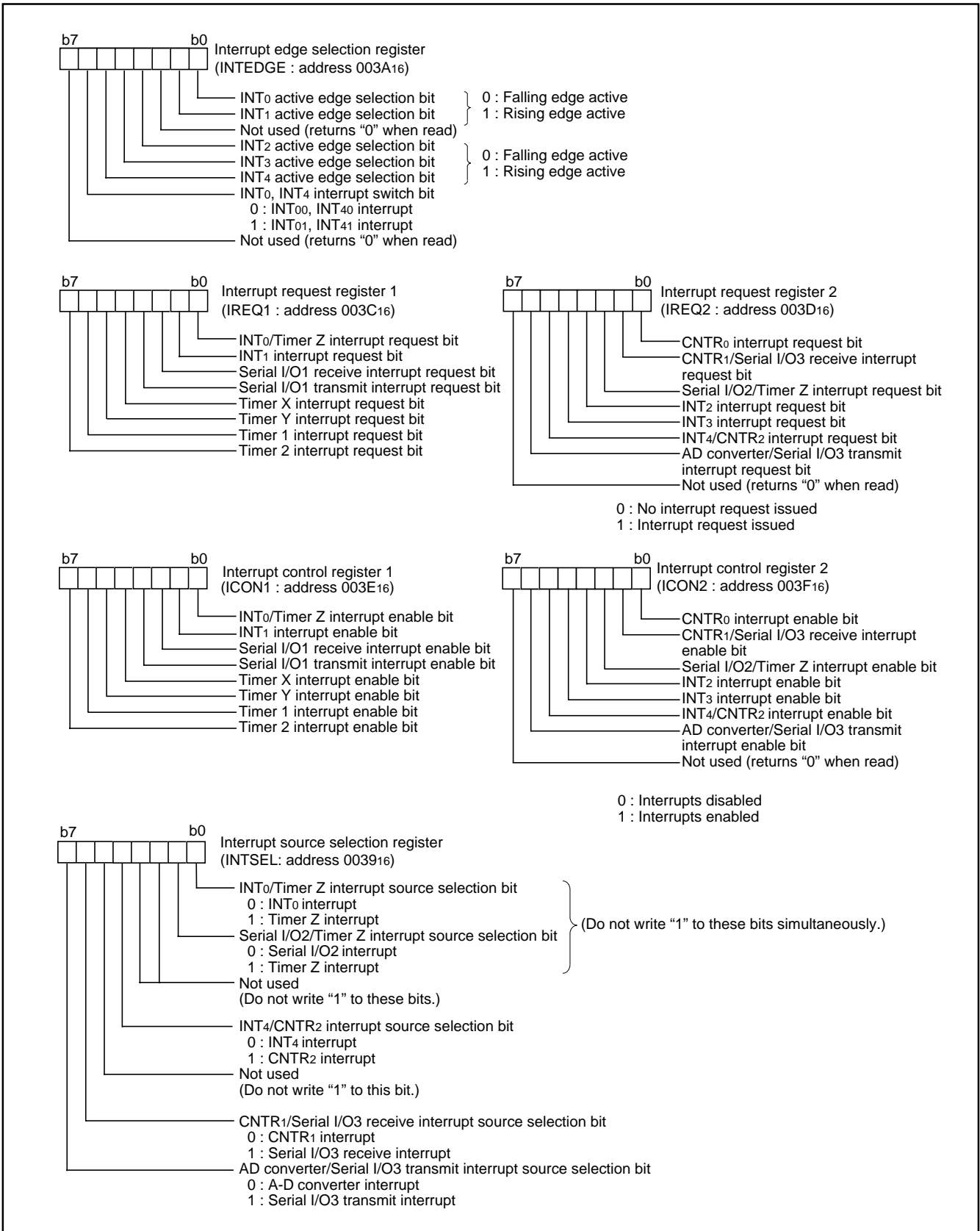

Fig. 25 Structure of interrupt-related registers of 3803 group

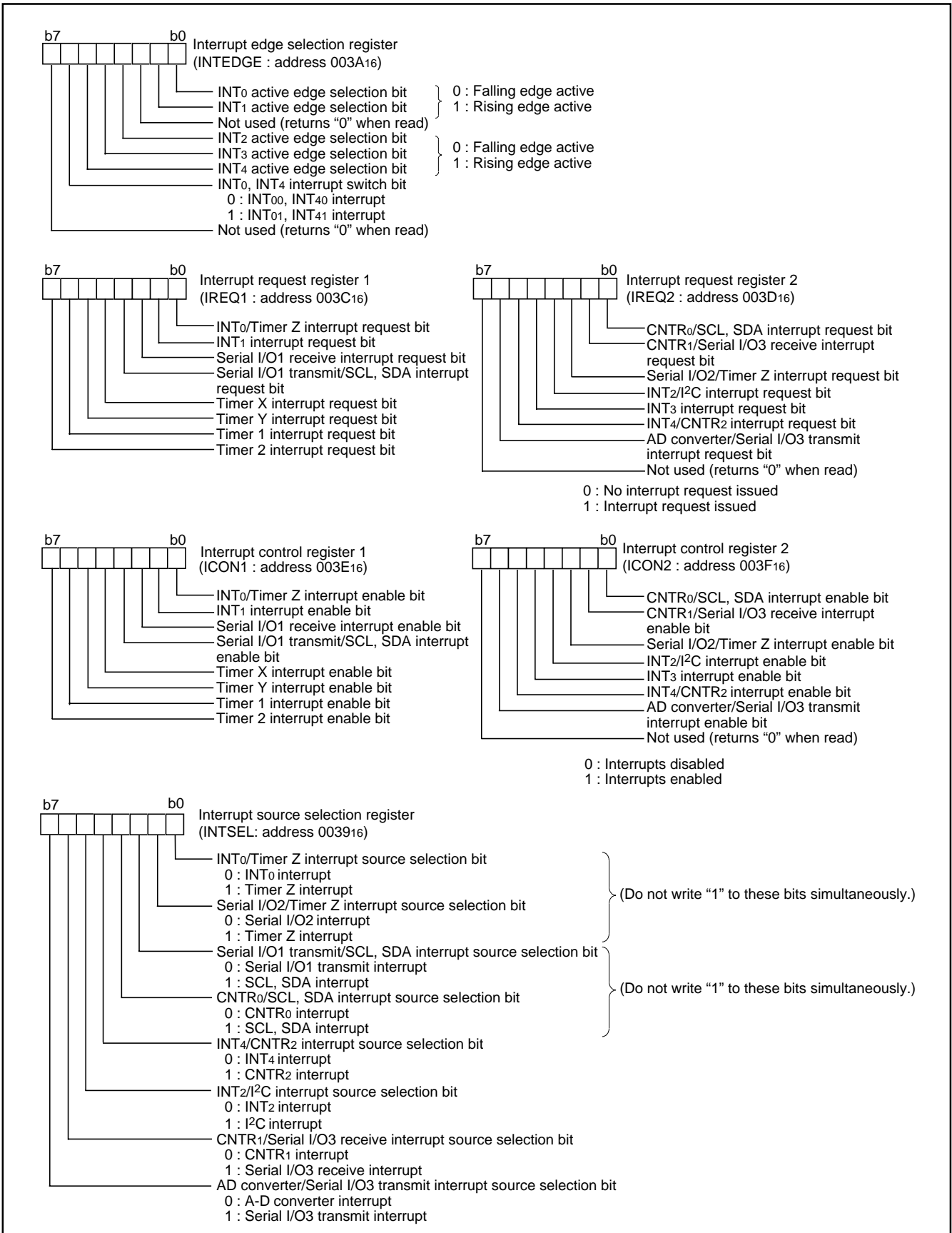

Fig. 26 Structure of interrupt-related registers of 3804 group

TIMERS

●8-bit Timers

The 3803/3804 group has four 8-bit timers: timer 1, timer 2, timer X, and timer Y.

The timer 1 and timer 2 use one prescaler in common, and the timer X and timer Y use each prescaler. Those are 8-bit prescalers. Each of the timers and prescalers has a timer latch or a prescaler latch.

The division ratio of each timer or prescaler is given by $1/(n + 1)$, where n is the value in the corresponding timer or prescaler latch. All timers are down-counters. When the timer reaches "0016", an underflow occurs at the next count pulse and the contents of the corresponding timer latch are reloaded into the timer and the count is continued. When the timer underflows, the interrupt request bit corresponding to that timer is set to "1".

●Timer divider

Each of the prescaler 12, the prescaler X and the prescaler Y has a divider for the count source. The XIN or XCIN, which is switched by the CPU mode register (bits 7 and 6 at address 003B16), can be used as the divider count source. Each division ratio is controlled by the timer 12, X count source selection register and the timer Y, Z count source selection register. It can be selected among 1/2, 1/4, 1/8, 1/16, 1/32, 1/64, 1/128, 1/256, 1/512 and 1/1024 of $f(XIN)$ or $f(XCIN)$; and $f(XCIN)$.

Timer 1 and Timer 2

The timer 1 and timer 2 can select the count source of prescaler 12 by the timer 12 count source selection bits of timer 12, X count source selection register (bits 3 to 0 at address 000E16) among 1/2, 1/4, 1/8, 1/16, 1/32, 1/64, 1/128, 1/256, 1/512 and 1/1024 of $f(XIN)$ or $f(XCIN)$.

The timer 1 and timer 2 counts the output of prescaler 12 and periodically set the interrupt request bit.

Timer X and Timer Y

The timer X can select the count source of prescaler X by the timer X count source selection bits of timer 12, X count source selection register (bits 7 to 4 at address 000E16).

The timer Y can select the count source of prescaler Y by the timer Y count source selection bits of timer Y, Z count source selection register (bits 3 to 0 at address 000F16).

The timer X and timer Y can each select one of four operating modes by setting the timer XY mode register (address 002316).

(1) Timer mode

●Mode selection

This mode can be selected by setting "00" to the timer X operating mode bits (bits 1 and 0) and the timer Y operating mode bits (bits 5 and 4) of the timer XY mode register (address 002316).

The signal dividing oscillation frequency to the division ratio set into the divider is counted.

●Count source selection

In high- or middle-speed mode, 1/2, 1/4, 1/8, 1/16, 1/32, 1/64, 1/128, 1/256, 1/512 or 1/1024 of $f(XIN)$; or $f(XCIN)$ can be selected as the count source.

In low-speed mode, 1/2, 1/4, 1/8, 1/16, 1/32, 1/64, 1/128, 1/256, 1/

512 or 1/1024 of $f(XCIN)$; or $f(XCIN)$ can be selected as the count source.

●Interrupt

When an underflow occurs, the timer X interrupt request bit (bit 4) or timer Y interrupt request bit (bit 5) of the interrupt request register 1 (address 003C16) is set to "1".

●Explanation of operation

The timer count operation is started by setting "0" to the timer X count stop bit (bit 3) and the timer Y count stop bit (bit 7) of the timer XY mode register (address 002316).

When the timer reaches "0016", an underflow occurs at the next count pulse and the contents of timer latch are reloaded into the timer and the count is continued.

When writing data to the timer during count operation, the data is written only into the latch. Then the new latch value is reloaded into the timer at the next underflow.

(2) Pulse output mode

●Mode selection

This mode can be selected by setting "01" to the timer X operating mode bits (bits 1 and 0) and the timer Y operating mode bits (bits 5 and 4) of the timer XY mode register (address 002316).

●Count source selection

In high- or middle-speed mode, 1/2, 1/4, 1/8, 1/16, 1/32, 1/64, 1/128, 1/256, 1/512 or 1/1024 of $f(XIN)$; or $f(XCIN)$ can be selected as the count source.

In low-speed mode, 1/2, 1/4, 1/8, 1/16, 1/32, 1/64, 1/128, 1/256, 1/512 or 1/1024 of $f(XCIN)$; or $f(XCIN)$ can be selected as the count source.

●Interrupt

The interrupt at an underflow is the same as the timer mode's.

●Explanation of operation

The operation is the same as the timer mode's. Moreover the pulse which is inverted each time the timer underflows is output from CNTR0/CNTR1 pin. When the CNTR0 active edge switch bit (bit 2) and the CNTR1 active edge switch bit (bit 6) of the timer XY mode register (address 002316) is "0", the output starts with "H" level. When it is "1", the output starts with "L" level.

■Precautions

Set the double-function port of CNTR0/CNTR1 pin and port P54/P55 to output in this mode.

[During timer operation stop]

The output from CNTR0/CNTR1 pin is initialized to the level depending on CNTR0/CNTR1 active edge switch bit by writing to the timer.

[During timer operation enabled]

When the value of the CNTR0/CNTR1 active edge switch bit is

changed, the output level of CNTR0/CNTR1 pin is inverted.

(3) Event counter mode

●Mode selection

This mode can be selected by setting "10" to the timer X operating mode bits (bits 1 and 0) and the timer Y operating mode bits (bits 5 and 4) of the timer XY mode register (address 002316).

The valid edge for the count operation depends on the CNTR0 active edge switch bit (bit 2) or the CNTR1 active edge switch bit (bit 6) of the timer XY mode register (address 002316). When it is "0", the rising edge is valid. When it is "1", the falling edge is valid.

●Interrupt

The interrupt at an underflow is the same as the timer mode's.

●Explanation of operation

The operation is the same as the timer mode's.

Set the double-function port of CNTR0/CNTR1 pin and port P54/P55 to input in this mode.

(4) Pulse width measurement mode

●Mode selection

This mode can be selected by setting "11" to the timer X operating mode bits (bits 1 and 0) and the timer Y operating mode bits (bits 5 and 4) of the timer XY mode register (address 002316).

●Count source selection

In high- or middle-speed mode, 1/2, 1/4, 1/8, 1/16, 1/32, 1/64, 1/128, 1/256, 1/512 or 1/1024 of $f(XIN)$; or $f(XCIN)$ can be selected as the count source.

In low-speed mode, 1/2, 1/4, 1/8, 1/16, 1/32, 1/64, 1/128, 1/256, 1/512 or 1/1024 of $f(XCIN)$; or $f(XCIN)$ can be selected as the count source.

●Explanation of operation

[During timer operation stop]

Select the count source. Next, select the term of the pulse widths to be measured. When the CNTR0 active edge switch bit (bit 2) or the CNTR1 active edge switch bit (bit 6) of the timer XY mode register (address 002316) is "1", the timer counts during the term of one falling edge of CNTR0/CNTR1 pin input until the next rising edge of input ("L" term). When it is "0", the timer counts during the term of one rising edge input until the next falling edge input ("H" term).

[During timer operation enabled]

The pulse width measurement starts by setting "0" to the timer X count stop bit (bit 3) or the timer Y count stop bit (bit 7) of the timer XY mode register (address 002316), and the timer counts down from the value that was set to the timer before the start of measurement.

When the valid edge of measurement completion is detected, the 1's complement of the timer value is written to the timer latch.

When the valid edge of measurement start/completion is detected, "FF16" is set to the prescaler and the timer.

Furthermore when the timer underflows, the timer X/Y interrupt request occurs and "FF16" is set to the prescaler and the timer. The

measured value is retained until the next measurement completion.

■Precautions

Set the double-function port of CNTR0/CNTR1 pin and port P54/P55 to input in this mode.

A read-out of timer value is impossible in this mode. The timer can be written to only during timer stop (no measurement of pulse widths).

Since the timer latch in this mode is specialized for the read-out of measured values, do not perform any write operation during measurement.

■Precautions regarding all modes

The count operation can be stopped by setting "1" to the timer X count stop bit (bit 3) and the timer Y count stop bit (bit 7) of the timer XY mode register (address 002316). The interrupt request bit is set to "1" each time the timer underflows.

When switching the count source by the timer 12, X and Y count source selection bits, the value of timer count is altered in considerable amount owing to generating of thin pulses on the count input signals.

Therefore, select the timer count source before setting the value to the prescaler and the timer.

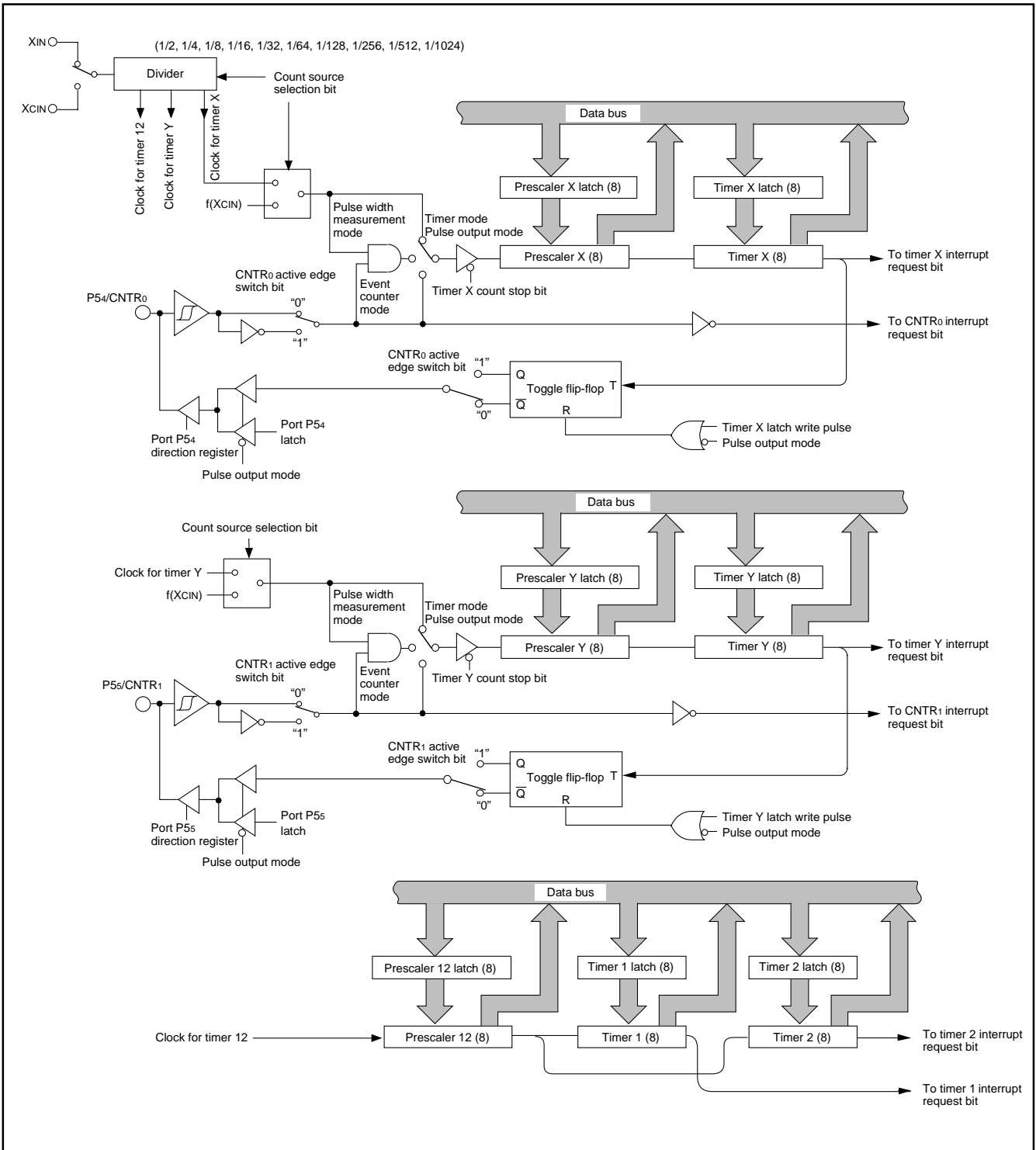

Fig. 27 Block diagram of timer X, timer Y, timer 1, and timer 2

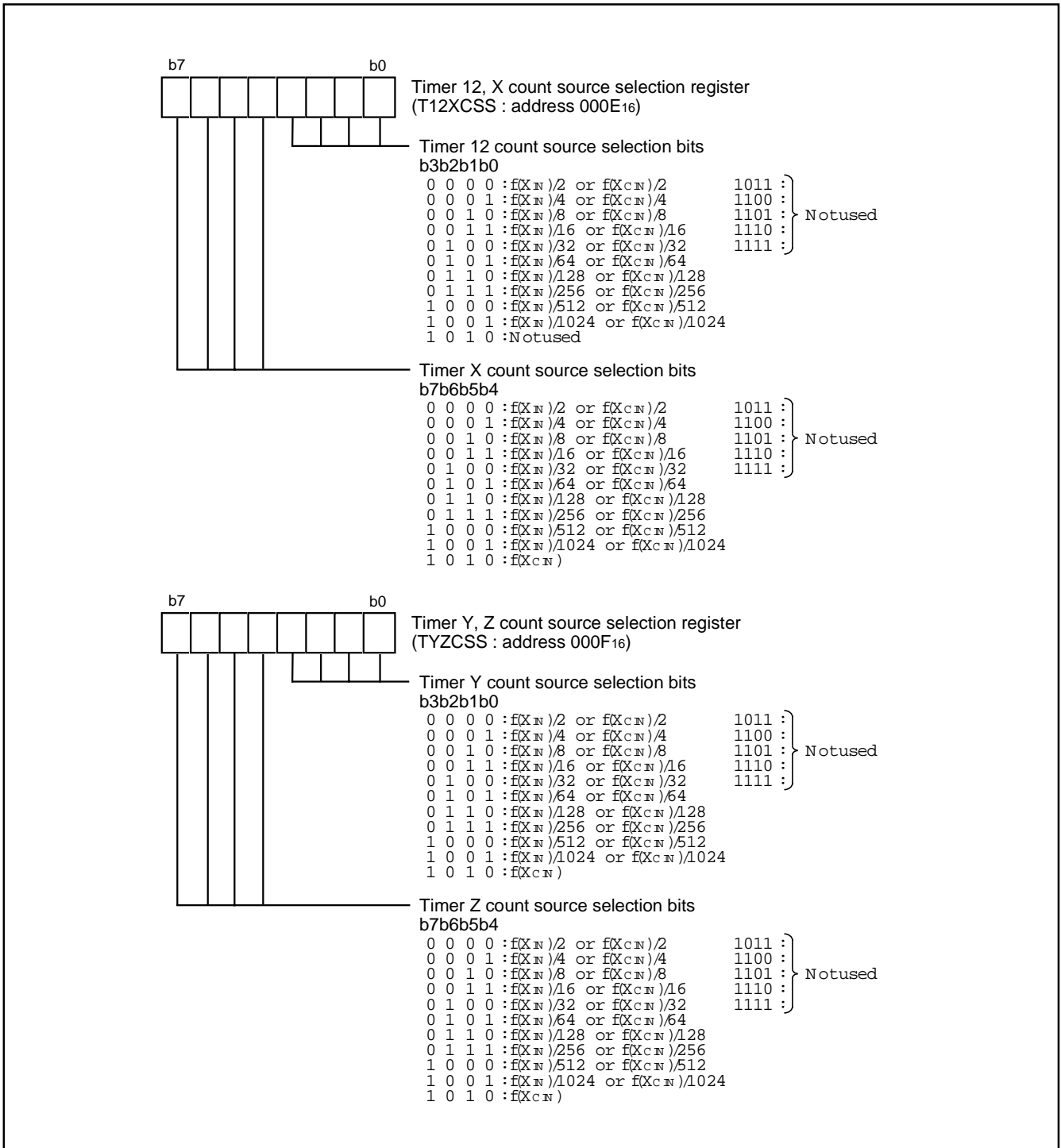

Fig. 29 Structure of timer 12, X and timer Y, Z count source selection registers

●16-bit Timers

The timer Z is a 16-bit timer. When the timer reaches "0000₁₆", an underflow occurs at the next count pulse and the corresponding timer latch is reloaded into the timer and the count is continued. When the timer underflows, the interrupt request bit corresponding to the timer Z is set to "1".

Read and write operation to a 16-bit timer must be performed for both high- and low-order bytes. When reading a 16-bit timer, read from the high-order byte first, followed by the low-order byte. When writing to a 16-bit timer, write to the low-order byte first, followed by the high-order byte. The 16-bit timer cannot perform the correct operation when reading during write operation, or when writing during read operation.

The timer Z can select the count source by the timer Z count source selection bits of timer Y, Z count source selection register (bits 7 to 4 at address 000F₁₆).

Timer Z can select one of six operating modes by setting the timer Z mode register (address 002A₁₆).

(1) Timer mode

●Mode selection

This mode can be selected by setting "000" to the timer Z operating mode bits (bits 2 to 0) of the timer Z mode register (address 002A₁₆).

●Count source selection

In high- or middle-speed mode, 1/2, 1/4, 1/8, 1/16, 1/32, 1/64, 1/128, 1/256, 1/512 or 1/1024 of f(XIN); or f(XCIN) can be selected as the count source.

In low-speed mode, 1/2, 1/4, 1/8, 1/16, 1/32, 1/64, 1/128, 1/256, 1/512 or 1/1024 of f(XCIN); or f(XCIN) can be selected as the count source.

●Interrupt

When an underflow occurs, the INT0/timer Z interrupt request bit (bit 0) of the interrupt request register 1 (address 003C₁₆) is set to "1".

●Explanation of operation

After reset release, the timer Z count stop bit (bit 6) of the timer Z mode register (address 002A₁₆) is "1" and the timer stops. During timer stop, usually write data to a latch and a timer at the same time to set the timer value.

The timer count operation is started by setting "0" to the timer Z count stop bit (bit 6) of the timer Z mode register (address 002A₁₆).

When the timer reaches "0000₁₆", an underflow occurs at the next count pulse and the contents of timer latch are reloaded into the timer and the count is continued.

When writing data to the timer during operation, the data is written only into the latch. Then the new latch value is reloaded into the timer at the next underflow.

(2) Event counter mode

●Mode selection

This mode can be selected by setting "000" to the timer Z operating mode bits (bits 2 to 0) and the timer/event counter mode switch bit (bit 7) of the timer Z mode register (address 002A₁₆).

The valid edge for the count operation depends on the CNTR2 active edge switch bit (bit 5) of the timer Z mode register (address 002A₁₆). When it is "0", the rising edge is valid. When it is "1", the falling edge is valid.

●Interrupt

The interrupt at an underflow is the same as the timer mode's.

●Explanation of operation

The operation is the same as the timer mode's.

Set the double-function port of CNTR2 pin and port P47 to input in this mode.

Figure 32 shows the timing chart of the timer/event counter mode.

(3) Pulse output mode

●Mode selection

This mode can be selected by setting "001" to the timer Z operating mode bits (bits 2 to 0) of the timer Z mode register (address 002A₁₆).

●Count source selection

In high- or middle-speed mode, 1/2, 1/4, 1/8, 1/16, 1/32, 1/64, 1/128, 1/256, 1/512 or 1/1024 of f(XIN); or f(XCIN) can be selected as the count source.

In low-speed mode, 1/2, 1/4, 1/8, 1/16, 1/32, 1/64, 1/128, 1/256, 1/512 or 1/1024 of f(XCIN); or f(XCIN) can be selected as the count source.

●Interrupt

The interrupt at an underflow is the same as the timer mode's.

●Explanation of operation

The operation is the same as the timer mode's. Moreover the pulse which is inverted each time the timer underflows is output from CNTR2 pin. When the CNTR2 active edge switch bit (bit 5) of the timer Z mode register (address 002A₁₆) is "0", the output starts with "H" level. When it is "1", the output starts with "L" level.

■Precautions

Set the double-function port of CNTR2 pin and port P47 to output in this mode.

[During timer operation stop]

The output from CNTR2 pin is initialized to the level depending on CNTR2 active edge switch bit by writing to the timer.

[During timer operation enabled]

When the value of the CNTR2 active edge switch bit is changed, the output level of CNTR2 pin is inverted.

Figure 33 shows the timing chart of the pulse output mode.

(4) Pulse period measurement mode

●Mode selection

This mode can be selected by setting "010" to the timer Z operating mode bits (bits 2 to 0) of the timer Z mode register (address 002A16).

●Count source selection

In high- or middle-speed mode, 1/2, 1/4, 1/8, 1/16, 1/32, 1/64, 1/128, 1/256, 1/512 or 1/1024 of $f(XIN)$; or $f(XCIN)$ can be selected as the count source.

In low-speed mode, 1/2, 1/4, 1/8, 1/16, 1/32, 1/64, 1/128, 1/256, 1/512 or 1/1024 of $f(XCIN)$; or $f(XCIN)$ can be selected as the count source.

●Interrupt

The interrupt at an underflow is the same as the timer mode's. When the pulse period measurement is completed, the INT4/CNTR2 interrupt request bit (bit 5) of the interrupt request register 2 (address 003D16) is set to "1".

●Explanation of operation

[During timer operation stop]

Select the count source. Next, select the term of the pulse period to be measured. When the CNTR2 active edge switch bit (bit 5) of the timer Z mode register (address 002A16) is "0", the timer counts during the term of one falling edge of CNTR2 pin input until the next falling edge of input. When it is "1", the timer counts during the term of one rising edge input until the next rising edge input.

[During timer operation enabled]

The pulse period measurement starts by setting "0" to the timer Z count stop bit (bit 6) of the timer Z mode register (address 002A16), and the timer counts down from the value that was set to the timer before the start of measurement.

When the valid edge of measurement completion/start is detected, the 1's complement of the timer value is written to the timer latch and "FFFF16" is set to the timer.

Furthermore when the timer underflows, the timer Z interrupt request occurs and "FFFF16" is set to the timer. The measured value is retained until the next measurement completion.

■Precautions

Set the double-function port of CNTR2 pin and port P47 to input in this mode.

A read-out of timer value is impossible in this mode. The timer can be written to only during timer stop (no measurement of pulse period).

Since the timer latch in this mode is specialized for the read-out of measured values, do not perform any write operation during measurement.

"FFFF16" is set to the timer when the timer underflows or when the valid edge of measurement start/completion is detected. Consequently, the timer value at start of pulse period measurement depends on the timer value just before measurement start.

Figure 34 shows the timing chart of the pulse period measurement mode.

(5) Pulse width measurement mode

●Mode selection

This mode can be selected by setting "011" to the timer Z operating mode bits (bits 2 to 0) of the timer Z mode register (address 002A16).

●Count source selection

In high- or middle-speed mode, 1/2, 1/4, 1/8, 1/16, 1/32, 1/64, 1/128, 1/256, 1/512 or 1/1024 of $f(XIN)$; or $f(XCIN)$ can be selected as the count source.

In low-speed mode, 1/2, 1/4, 1/8, 1/16, 1/32, 1/64, 1/128, 1/256, 1/512 or 1/1024 of $f(XCIN)$; or $f(XCIN)$ can be selected as the count source.

●Interrupt

The interrupt at an underflow is the same as the timer mode's. When the pulse widths measurement is completed, the INT4/CNTR2 interrupt request bit (bit 5) of the interrupt request register 2 (address 003D16) is set to "1".

●Explanation of operation

[During timer operation stop]

Select the count source. Next, select the term of the pulse width to be measured. When the CNTR2 active edge switch bit (bit 5) of the timer Z mode register (address 002A16) is "1", the timer counts during the term of one falling edge of CNTR2 pin input until the next rising edge of input ("L" term). When it is "0", the timer counts during the term of one rising edge input until the next falling edge input ("H" term).

[During timer operation enabled]

The pulse width measurement starts by setting "0" to the timer Z count stop bit (bit 6) of the timer Z mode register (address 002A16), and the timer counts down from the value that was set to the timer before the start of measurement.

When the valid edge of measurement completion is detected, the 1's complement of the timer value is written to the timer latch.

When the valid edge of measurement start/completion is detected, "FFFF16" is set to the timer.

Furthermore when the timer underflows, the timer Z interrupt request occurs and "FFFF16" is set to the timer. The measured value is retained until the next measurement completion.

■Precautions

Set the double-function port of CNTR2 pin and port P47 to input in this mode.

A read-out of timer value is impossible in this mode. The timer can be written to only during timer stop (no measurement of pulse widths).

Since the timer latch in this mode is specialized for the read-out of measured values, do not perform any write operation during measurement.

"FFFF16" is set to the timer when the timer underflows or when the valid edge of measurement start/completion is detected. Consequently, the timer value at start of pulse width measurement depends on the timer value just before measurement start.

Figure 35 shows the timing chart of the pulse width measurement mode.

(6) Programmable waveform generating mode

●Mode selection

This mode can be selected by setting "100" to the timer Z operating mode bits (bits 2 to 0) of the timer Z mode register (address 002A16).

●Count source selection

In high- or middle-speed mode, 1/2, 1/4, 1/8, 1/16, 1/32, 1/64, 1/128, 1/256, 1/512 or 1/1024 of $f(X_{IN})$; or $f(X_{CIN})$ can be selected as the count source.

In low-speed mode, 1/2, 1/4, 1/8, 1/16, 1/32, 1/64, 1/128, 1/256, 1/512 or 1/1024 of $f(X_{CIN})$; or $f(X_{CIN})$ can be selected as the count source.

●Interrupt

The interrupt at an underflow is the same as the timer mode's.

●Explanation of operation

The operation is the same as the timer mode's. Moreover the timer outputs the data set in the output level latch (bit 4) of the timer Z mode register (address 002A16) from the CNTR2 pin each time the timer underflows.

Changing the value of the output level latch and the timer latch after an underflow makes it possible to output an optional waveform from the CNTR2 pin.

■Precautions

Set the double-function port of CNTR2 pin and port P47 to output in this mode.

Figure 36 shows the timing chart of the programmable waveform generating mode.

(7) Programmable one-shot generating mode

●Mode selection

This mode can be selected by setting "101" to the timer Z operating mode bits (bits 2 to 0) of the timer Z mode register (address 002A16).

●Count source selection

In high- or middle-speed mode, 1/2, 1/4, 1/8, 1/16, 1/32, 1/64, 1/128, 1/256, 1/512 or 1/1024 of $f(X_{IN})$; or $f(X_{CIN})$ can be selected as the count source.

●Interrupt

The interrupt at an underflow is the same as the timer mode's.

The trigger to generate one-shot pulse can be selected by the INT1 active edge selection bit (bit 1) of the interrupt edge selection register (address 003A16). When it is "0", the falling edge active is selected; when it is "1", the rising edge active is selected.

When the valid edge of the INT1 pin is detected, the INT1 interrupt request bit (bit 1) of the interrupt request register 1 (address 003C16) is set to "1".

●Explanation of operation

•"H" one-shot pulse; Bit 5 of timer Z mode register = "0"

[During timer operation stop]

The output level of CNTR2 pin is initialized to "L" at mode selection. Set the one-shot pulse width to the registers of timer Z low-order and high-order.

Trigger generating during timer stop (input signal to INT1 pin) is invalid.

[During timer operation enabled]

When trigger generating is detected, "H" is output from the CNTR2 pin. When an underflow occurs, "L" is output.

•"L" one-shot pulse; Bit 5 of timer Z mode register = "1"

[During timer operation stop]

The output level of CNTR2 pin is initialized to "H" at mode selection. Set the one-shot pulse width to the registers of timer Z low-order and high-order.

Trigger generating during timer stop (input signal to INT1 pin) is invalid.

[During timer operation enabled]

When trigger generating is detected, "L" is output from the CNTR2 pin. When an underflow occurs, "H" is output.

■Precautions

Set the double-function port of CNTR2 pin and port P47 to output, and of INT1 pin and port P42 to input in this mode.

This mode cannot be used in low-speed mode.

If the value of the CNTR2 active edge switch bit is changed during one-shot generating enabled or generating one-shot pulse, then the output level from CNTR2 pin changes.

Figure 37 shows the timing chart of the programmable one-shot generating mode.

■Notes regarding all modes

●Timer Z write control

Which write control can be selected by the timer Z write control bit (bit 3) of the timer Z mode register (address 002A16), writing data to both the latch and the timer at the same time or writing data only to the latch.

When the operation "writing data only to the latch" is selected, the value is set to the timer latch by writing data to the address of timer Z and the timer is updated at next underflow. After reset release, the operation "writing data to both the latch and the timer at the same time" is selected, and the value is set to both the latch and the timer at the same time by writing data to the address of timer Z.

In the case of writing data only to the latch, if writing data to the latch and an underflow are performed almost at the same time, the timer value may become undefined.

●Timer Z read control

A read-out of timer value is impossible in pulse period measurement mode and pulse width measurement mode. In the other modes, a read-out of timer value is possible regardless of count operating or stopped.

However, a read-out of timer latch value is impossible.

●Switch of interrupt active edge of CNTR2 and INT1

Each interrupt active edge depends on setting of the CNTR2 active edge switch bit and the INT1 active edge selection bit.

●Switch of count source

When switching the count source by the timer Z count source selection bits, the value of timer count is altered in inconsiderable amount owing to generating of thin pulses on the count input signals.

Therefore, select the timer count source before setting the value to the prescaler and the timer.

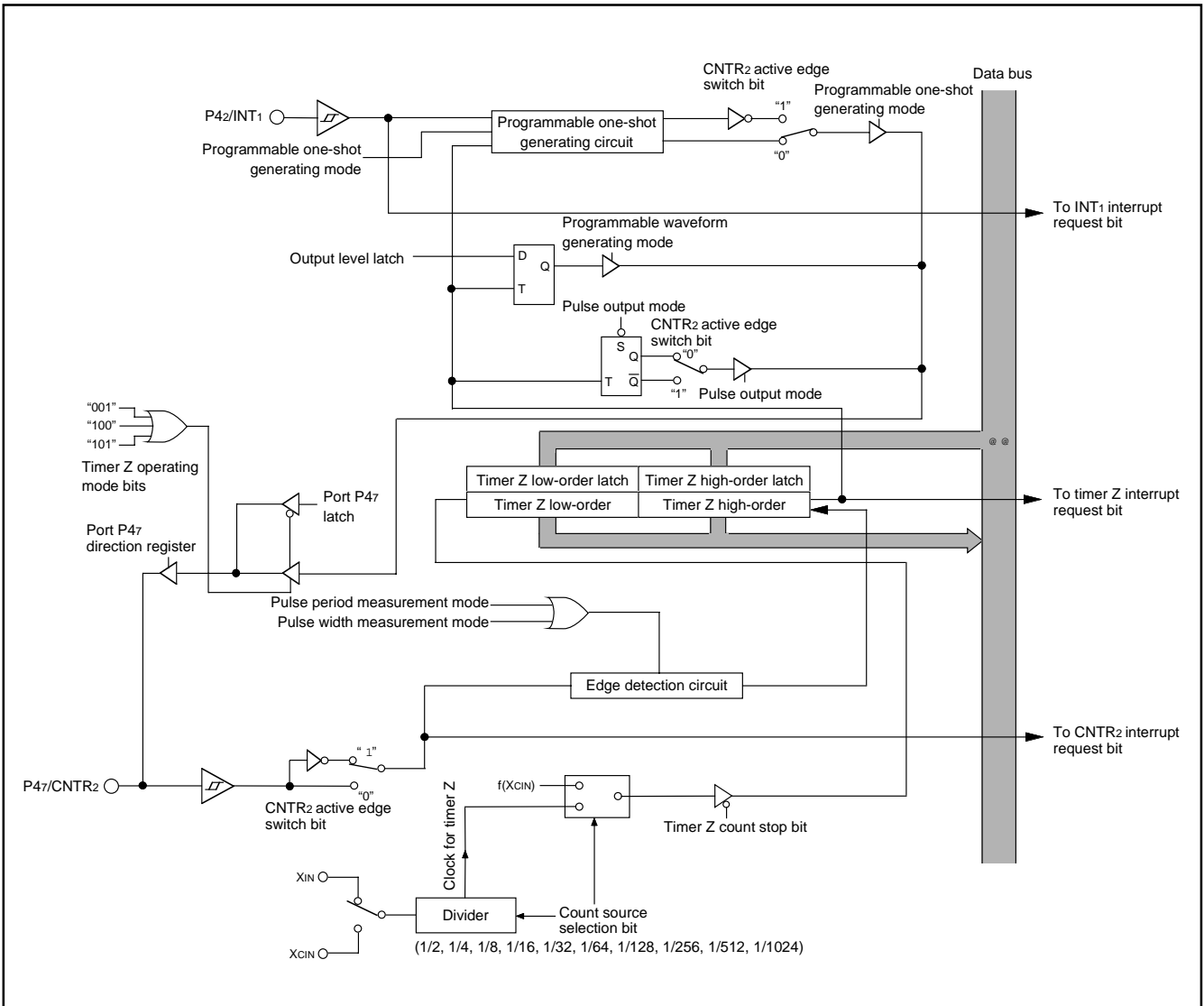

Fig. 30 Block diagram of timer Z

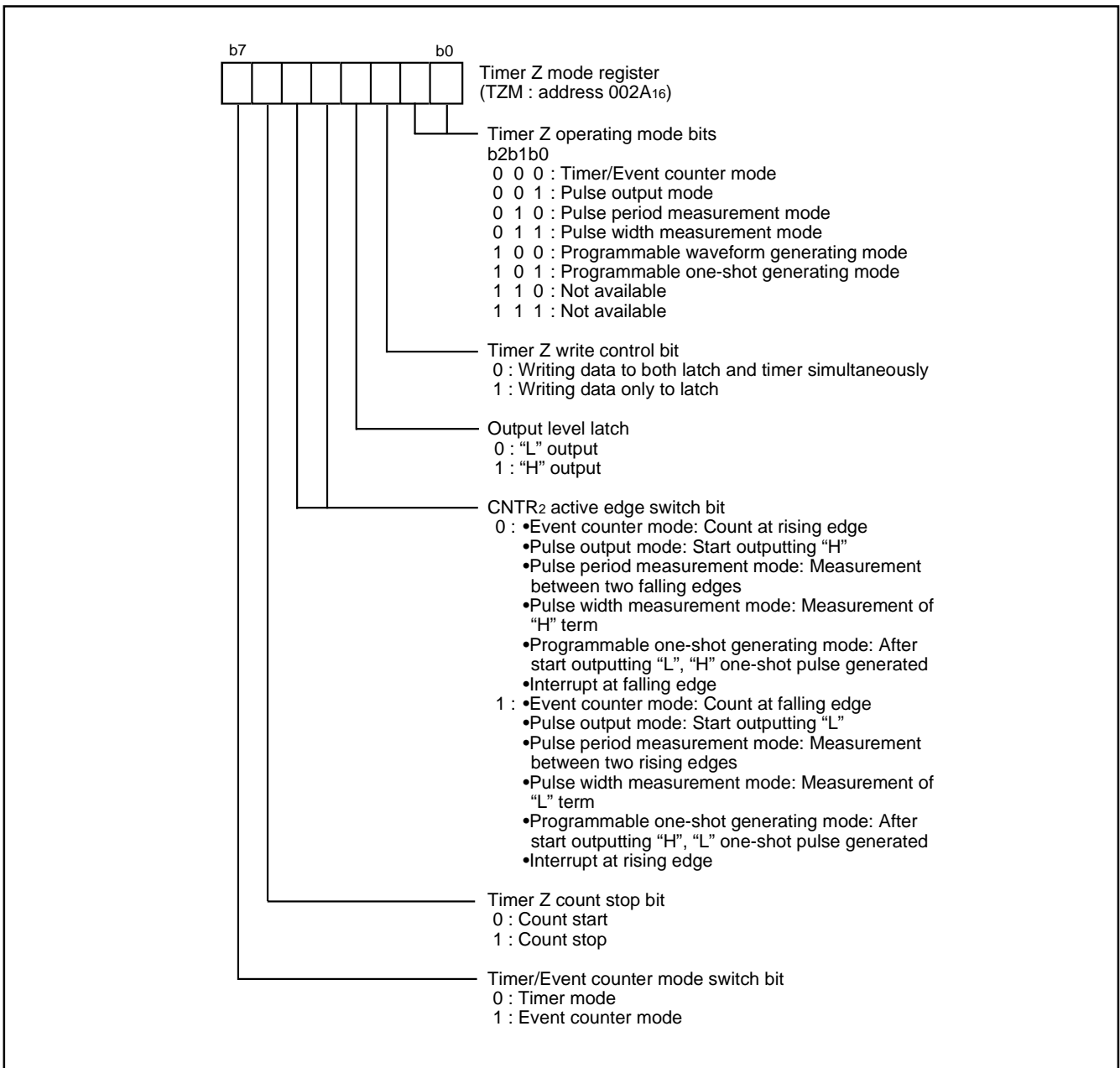

Fig. 31 Structure of timer Z mode register

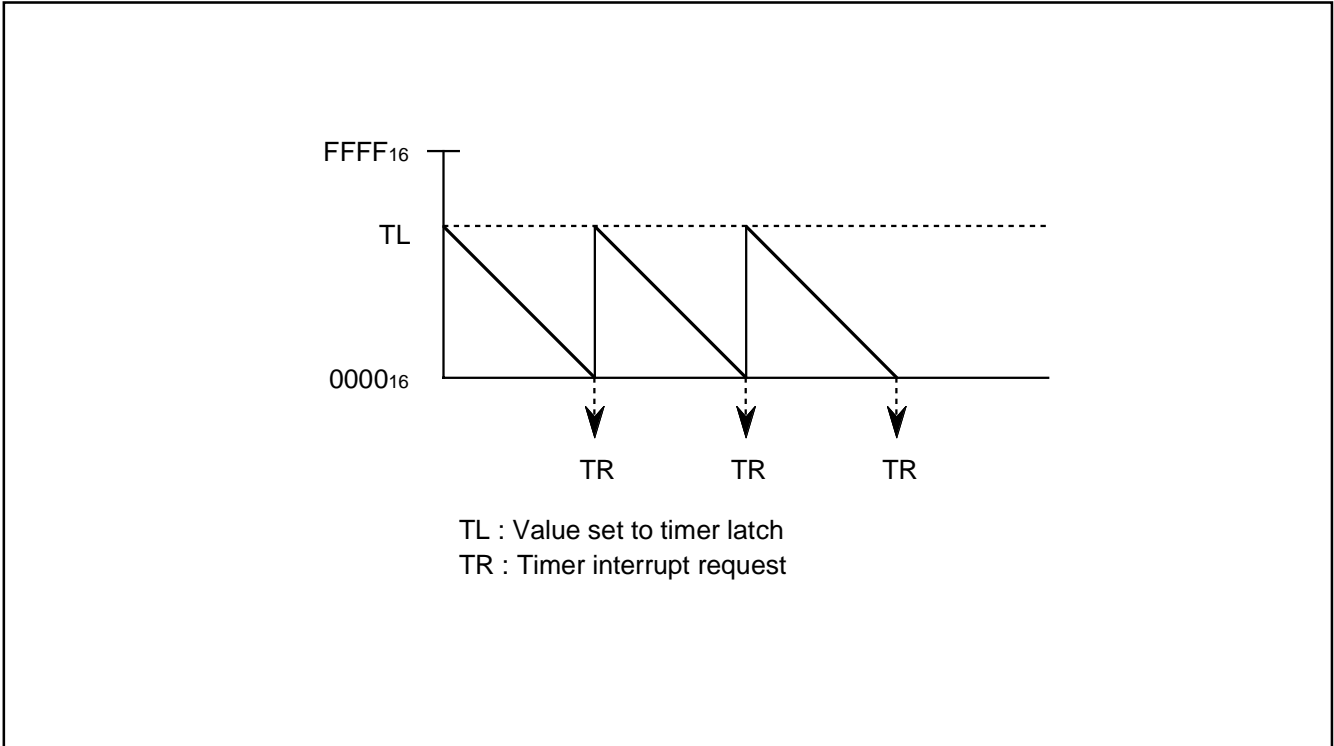

Fig. 32 Timing chart of timer/event counter mode

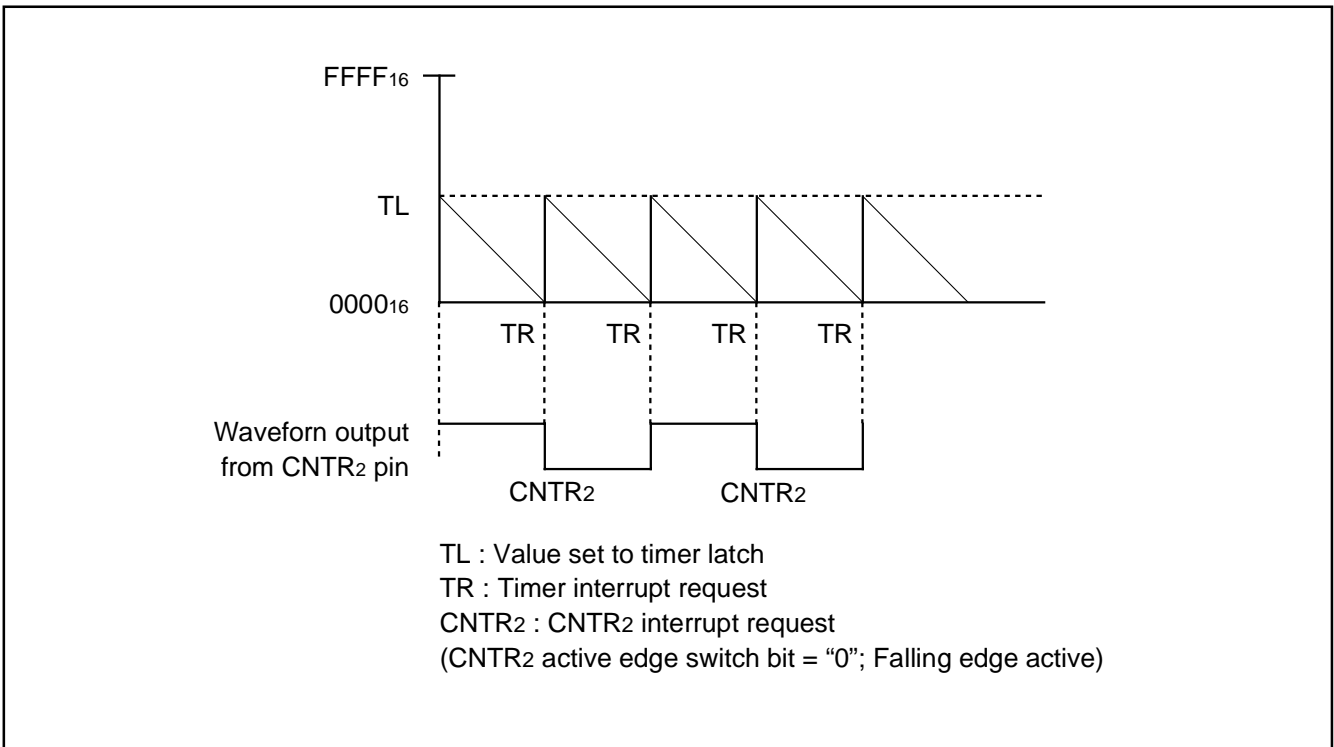

Fig. 33 Timing chart of pulse output mode

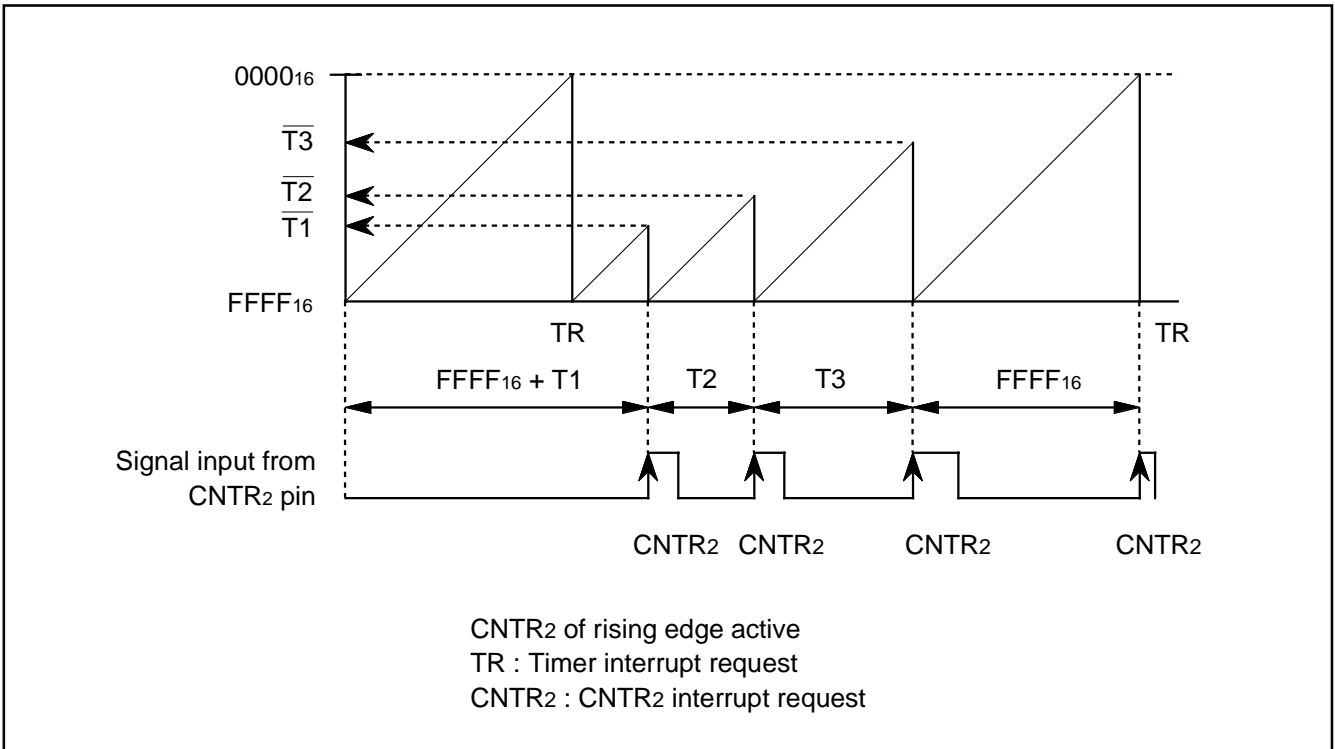

Fig. 34 Timing chart of pulse period measurement mode (Measuring term between two rising edges)

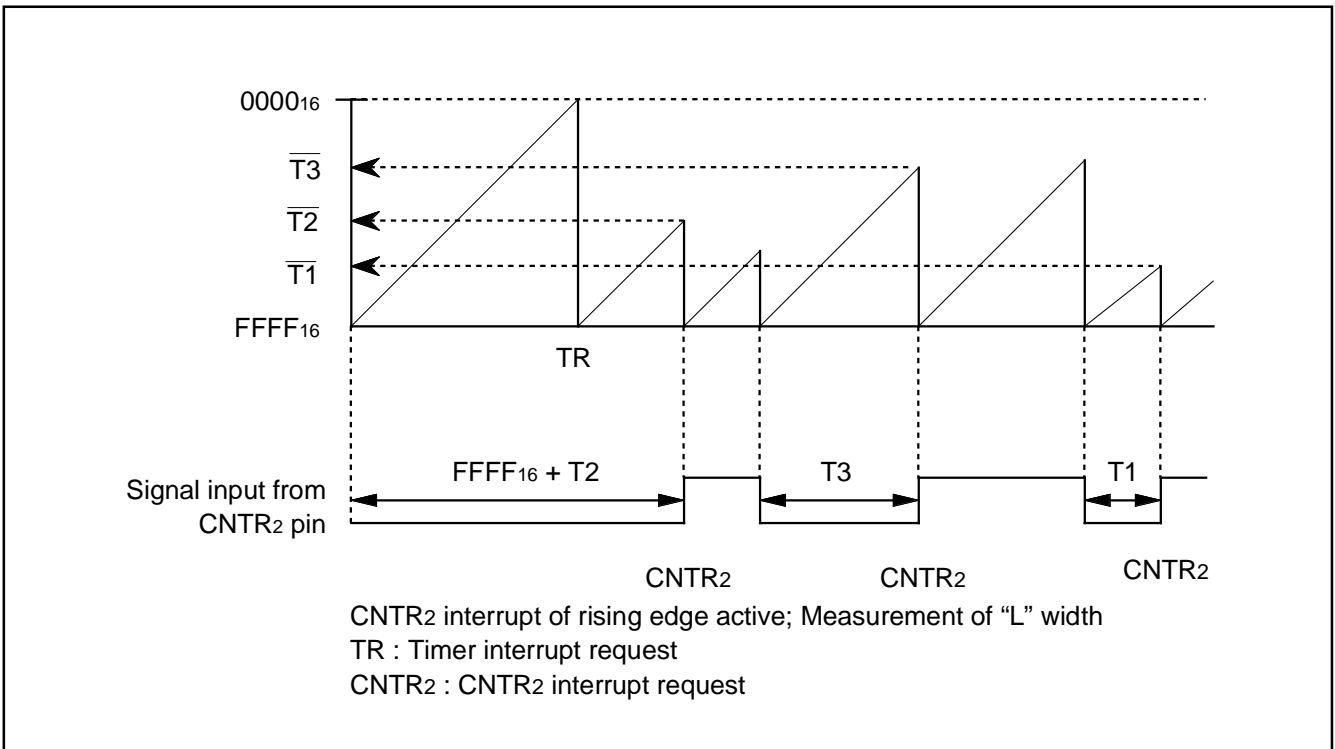

Fig. 35 Timing chart of pulse width measurement mode (Measuring "L" term)

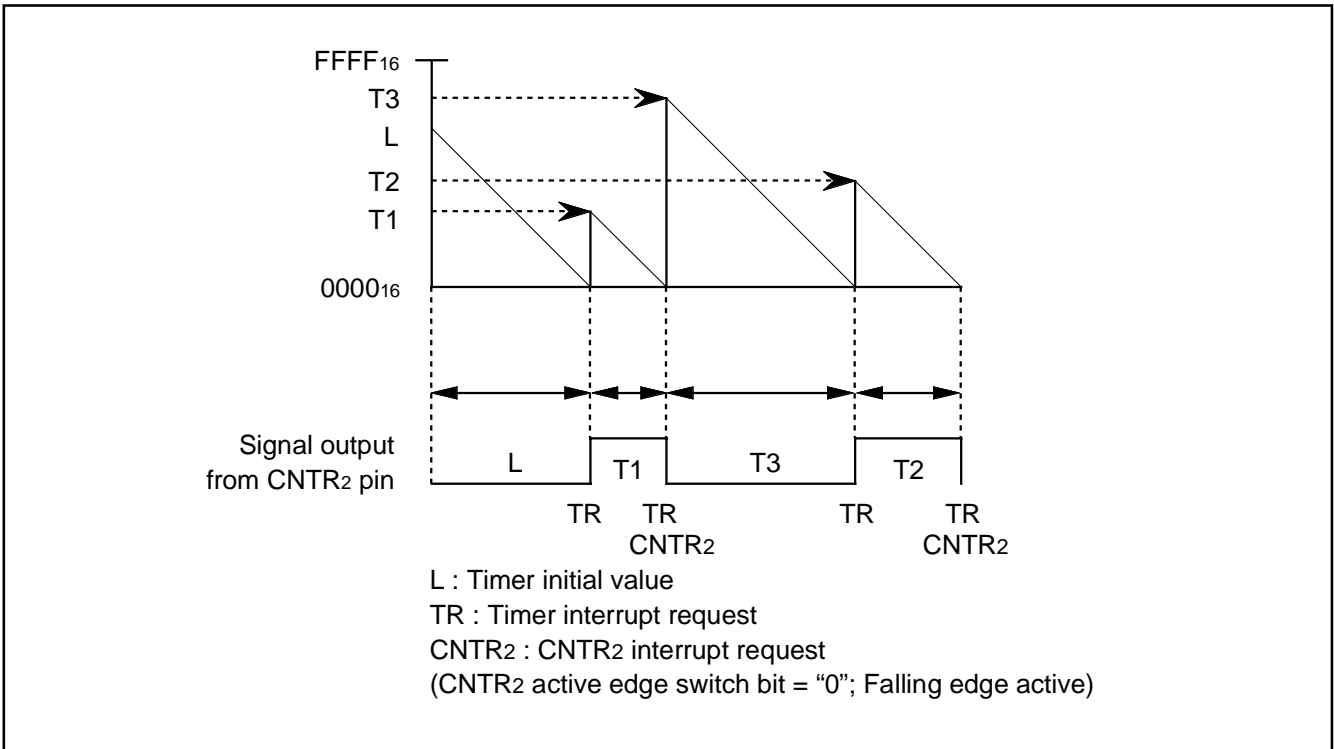

Fig. 36 Timing chart of programmable waveform generating mode

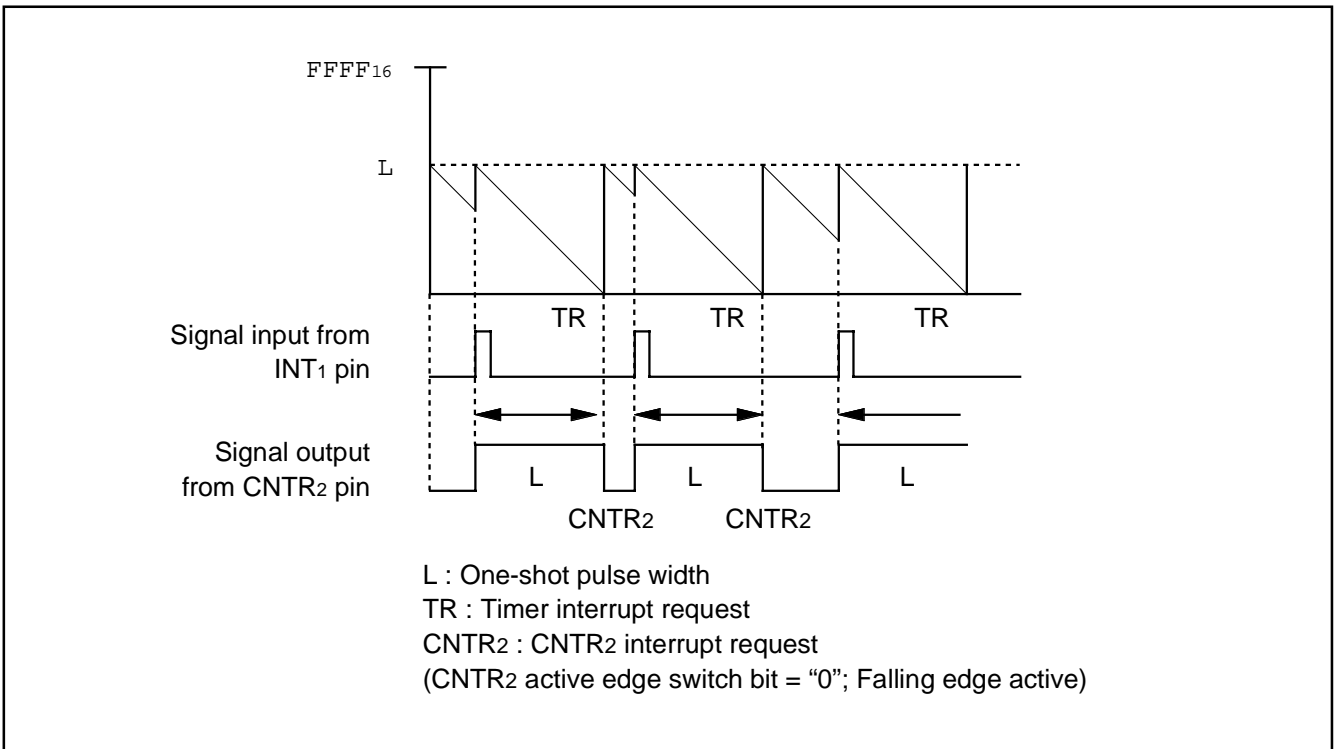

Fig. 37 Timing chart of programmable one-shot generating mode ("H" one-shot pulse generating)

**SERIAL I/O
Serial I/O1**

Serial I/O1 can be used as either clock synchronous or asynchronous (UART) serial I/O. A dedicated timer is also provided for baud rate generation.

(1) Clock Synchronous Serial I/O Mode

Clock synchronous serial I/O1 mode can be selected by setting the serial I/O1 mode selection bit of the serial I/O1 control register (bit 6 of address 001A16) to "1".

For clock synchronous serial I/O, the transmitter and the receiver must use the same clock. If an internal clock is used, transfer is started by a write signal to the transmit/receive buffer register.

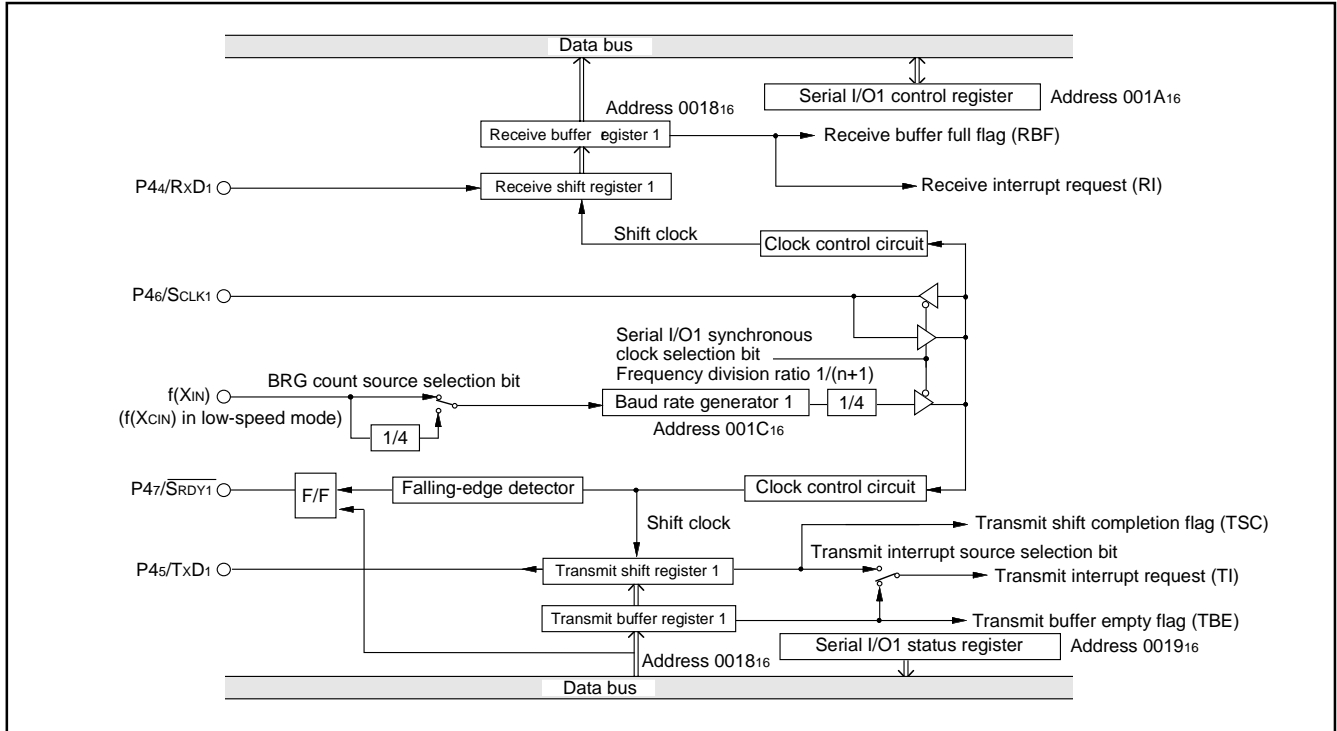

Fig. 38 Block diagram of clock synchronous serial I/O1

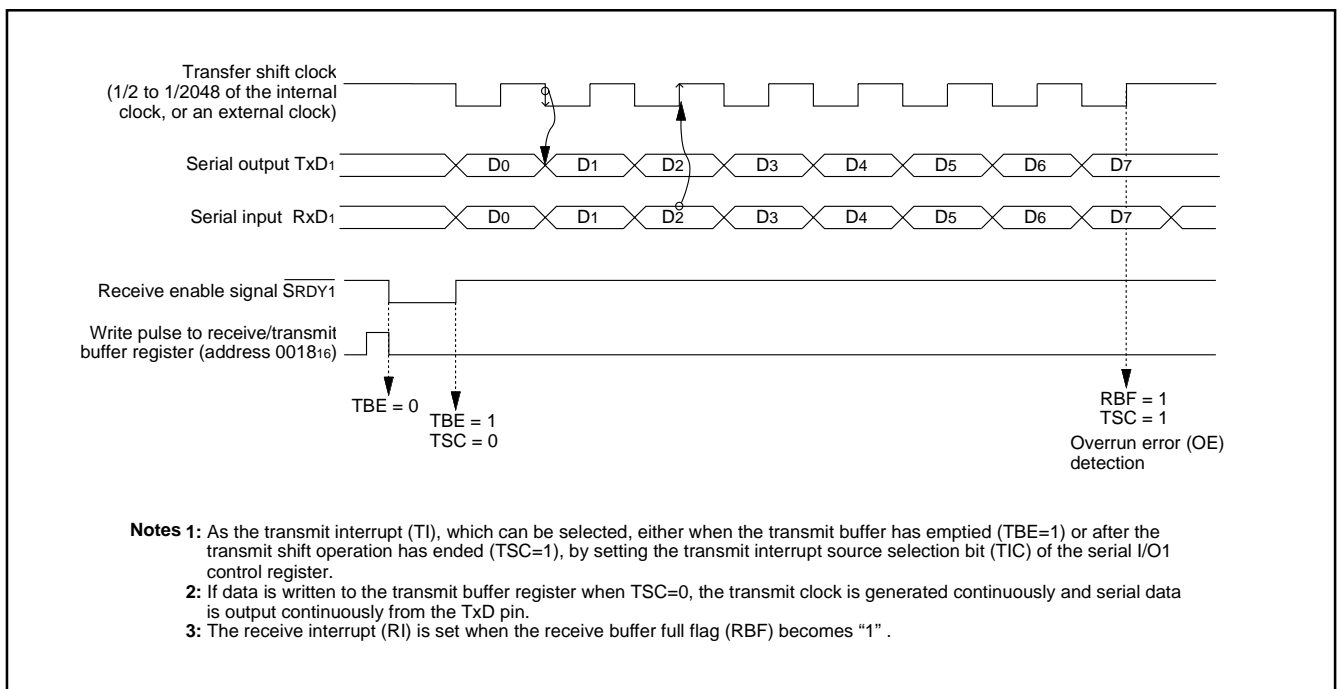

Fig. 39 Operation of clock synchronous serial I/O1

(2) Asynchronous Serial I/O (UART) Mode

Clock asynchronous serial I/O mode (UART) can be selected by clearing the serial I/O1 mode selection bit of the serial I/O1 control register to "0".

Eight serial data transfer formats can be selected, and the transfer formats used by a transmitter and receiver must be identical.

The transmit and receive shift registers each have a buffer, but the

two buffers have the same address in a memory. Since the shift register cannot be written to or read from directly, transmit data is written to the transmit buffer register, and receive data is read from the receive buffer register.

The transmit buffer register can also hold the next data to be transmitted, and the receive buffer register can hold a character while the next character is being received.

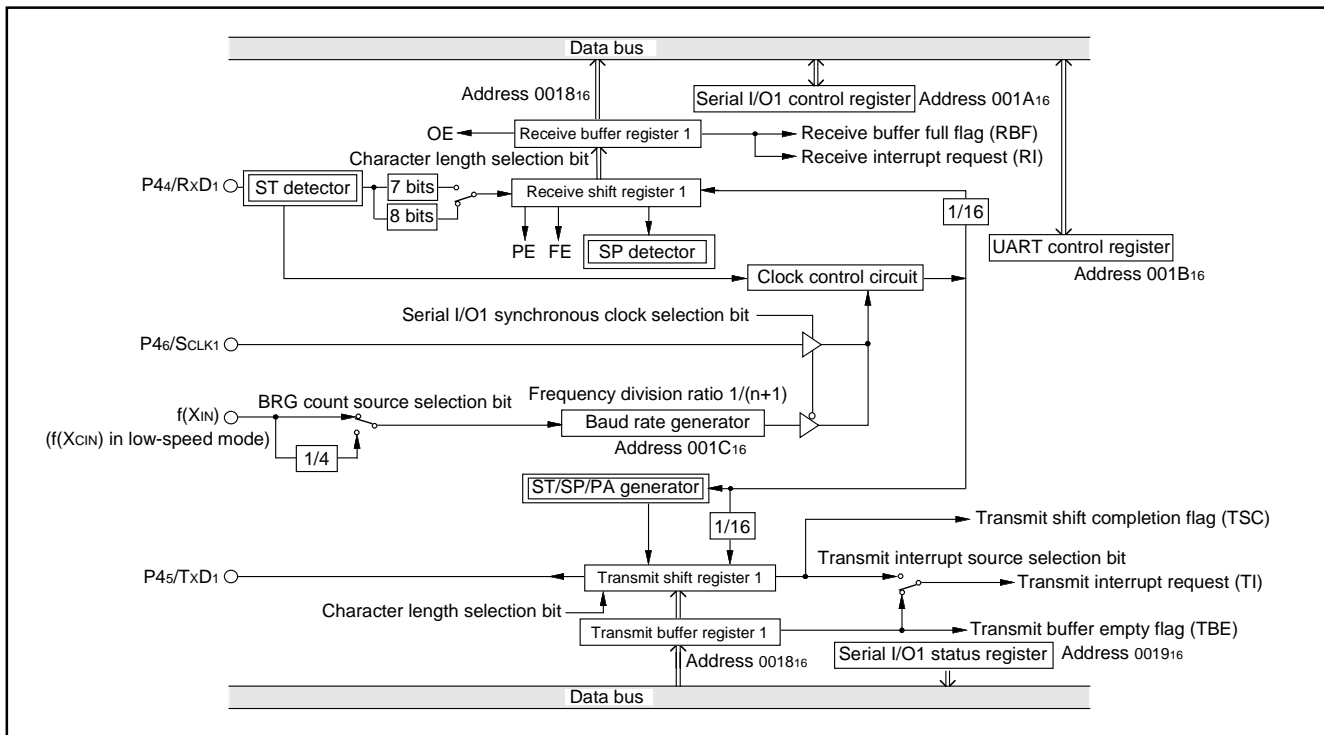

Fig. 40 Block diagram of UART serial I/O1

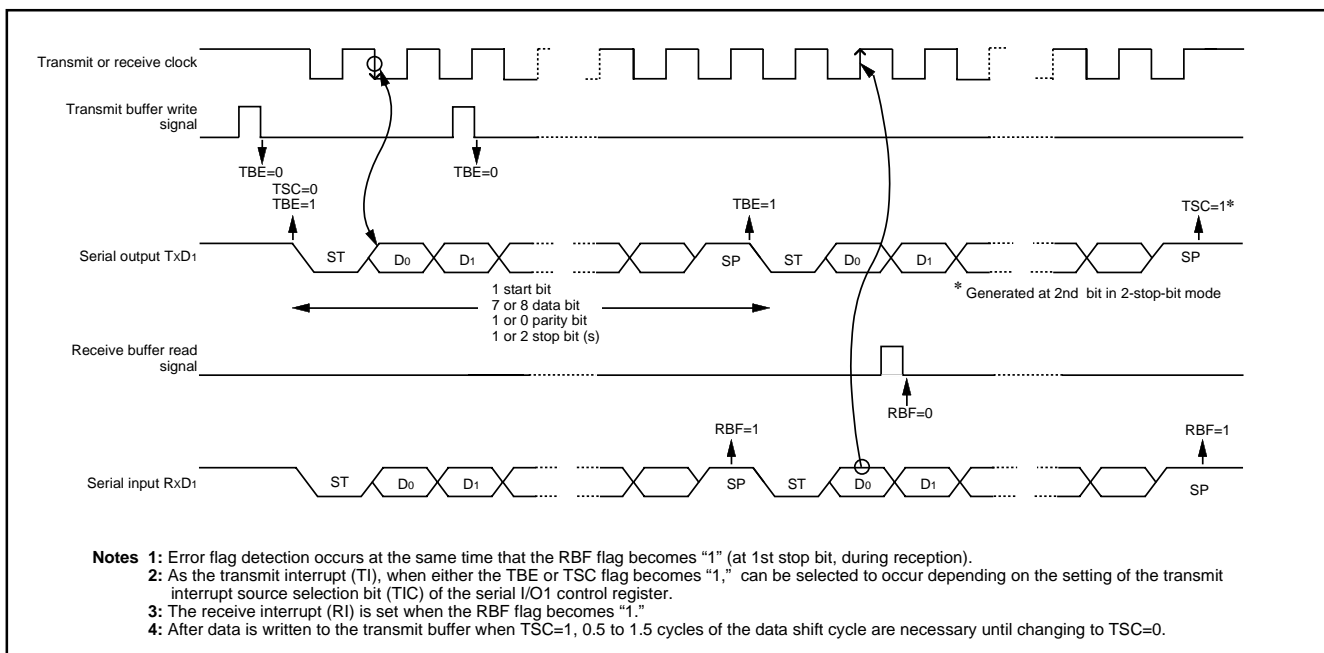

Fig. 41 Operation of UART serial I/O1

[Serial I/O1 Control Register (SIO1CON)]
001A16

The serial I/O1 control register consists of eight control bits for the serial I/O function.

[UART1 Control Register (UART1CON)]
001B16

The UART control register consists of four control bits (bits 0 to 3) which are valid when asynchronous serial I/O is selected and set the data format of an data transfer, and one bit (bit 4) which is always valid and sets the output structure of the P45/TxD1 pin.

[Serial I/O1 Status Register (SIO1STS)]
001916

The read-only serial I/O1 status register consists of seven flags (bits 0 to 6) which indicate the operating status of the serial I/O1 function and various errors.

Three of the flags (bits 4 to 6) are valid only in UART mode.

The receive buffer full flag (bit 1) is cleared to "0" when the receive buffer register is read.

If there is an error, it is detected at the same time that data is transferred from the receive shift register to the receive buffer register, and the receive buffer full flag is set. A write to the serial I/O1 status register clears all the error flags OE, PE, FE, and SE (bit 3 to bit 6, respectively). Writing "0" to the serial I/O1 enable bit SIOE (bit 7 of the serial I/O1 control register) also clears all the status flags, including the error flags.

Bits 0 to 6 of the serial I/O1 status register are initialized to "0" at reset, but if the transmit enable bit (bit 4) of the serial I/O1 control register has been set to "1", the transmit shift completion flag (bit 2) and the transmit buffer empty flag (bit 0) become "1".

[Transmit Buffer Register 1/Receive Buffer Register 1 (TB1/RB1)] 001816

The transmit buffer register 1 and the receive buffer register 1 are located at the same address. The transmit buffer is write-only and the receive buffer is read-only. If a character bit length is 7 bits, the MSB of data stored in the receive buffer is "0".

[Baud Rate Generator 1 (BRG1)] 001C16

The baud rate generator determines the baud rate for serial transfer.

The baud rate generator divides the frequency of the count source by $1/(n + 1)$, where n is the value written to the baud rate generator.

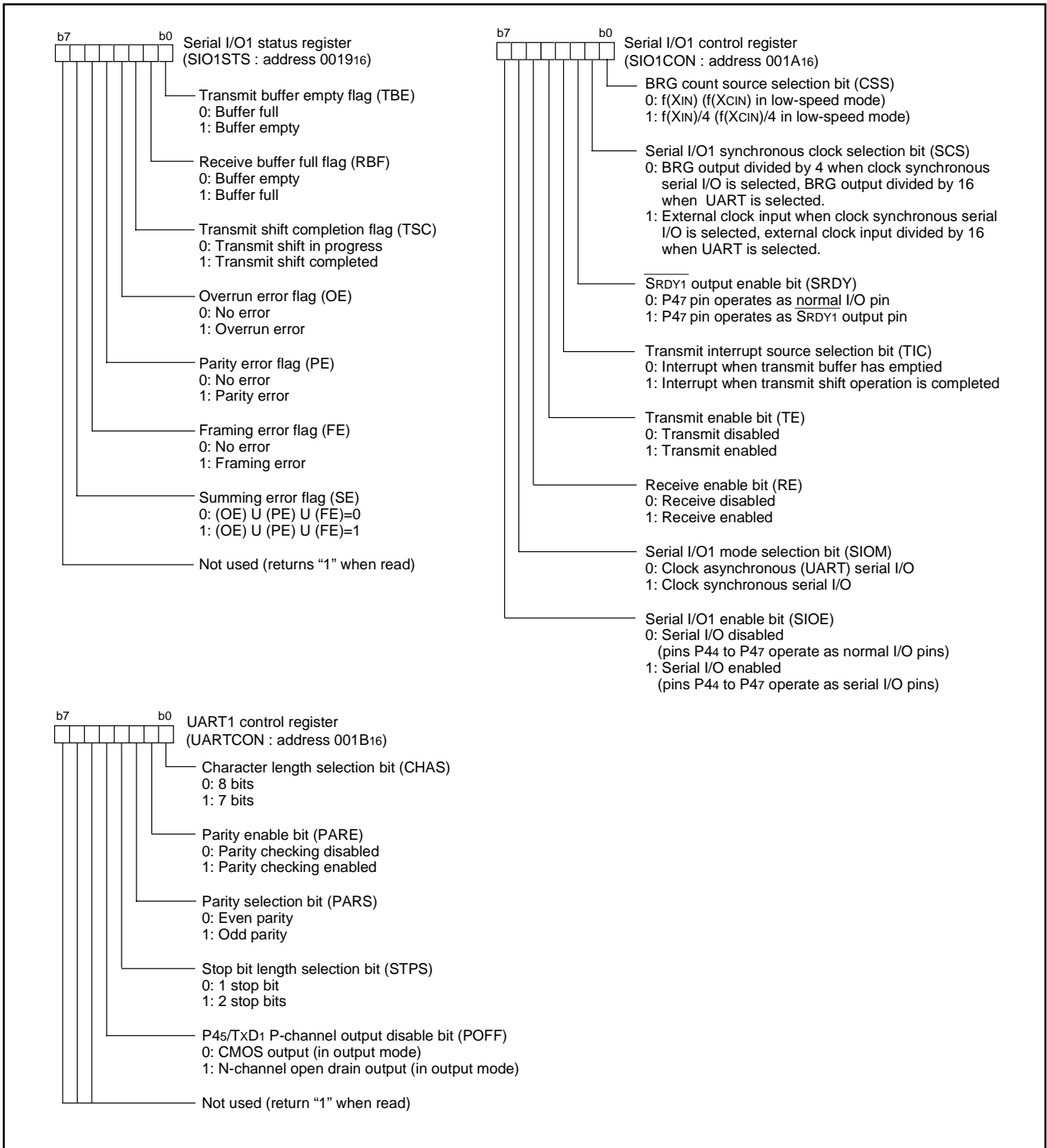

Fig. 42 Structure of serial I/O1 control registers

■ Notes concerning serial I/O1

1. Notes when selecting clock synchronous serial I/O

1.1 Stop of transmission operation

● Note

Clear the serial I/O enable bit and the transmit enable bit to "0" (serial I/O and transmit disabled).

● Reason

Since transmission is not stopped and the transmission circuit is not initialized even if only the serial I/O enable bit is cleared to "0" (serial I/O disabled), the internal transmission is running (in this case, since pins TxD, RxD, SCLK, and $\overline{\text{SRDY}}$ function as I/O ports, the transmission data is not output). When data is written to the transmit buffer register in this state, data starts to be shifted to the transmit shift register. When the serial I/O enable bit is set to "1" at this time, the data during internally shifting is output to the TxD pin and an operation failure occurs.

1.2 Stop of receive operation

● Note

Clear the receive enable bit to "0" (receive disabled), or clear the serial I/O enable bit to "0" (serial I/O disabled).

1.3 Stop of transmit/receive operation

● Note

Clear both the transmit enable bit and receive enable bit to "0" (transmit and receive disabled). (when data is transmitted and received in the clock synchronous serial I/O mode, any one of data transmission and reception cannot be stopped.)

● Reason

In the clock synchronous serial I/O mode, the same clock is used for transmission and reception. If any one of transmission and reception is disabled, a bit error occurs because transmission and reception cannot be synchronized.

In this mode, the clock circuit of the transmission circuit also operates for data reception. Accordingly, the transmission circuit does not stop by clearing only the transmit enable bit to "0" (transmit disabled). Also, the transmission circuit is not initialized by clearing the serial I/O enable bit to "0" (serial I/O disabled) (refer to 1.1).

2. Notes when selecting clock asynchronous serial I/O

2.1 Stop of transmission operation

● Note

Clear the transmit enable bit to "0" (transmit disabled).

● Reason

Since transmission is not stopped and the transmission circuit is not initialized even if only the serial I/O enable bit is cleared to "0" (serial I/O disabled), the internal transmission is running (in this case, since pins TxD, RxD, SCLK, and $\overline{\text{SRDY}}$ function as I/O ports, the transmission data is not output). When data is written to the transmit buffer register in this state, data starts to be shifted to the transmit shift register. When the serial I/O enable bit is set to "1" at this time, the data during internally shifting is output to the TxD pin and an operation failure occurs.

2.2 Stop of receive operation

● Note

Clear the receive enable bit to "0" (receive disabled).

2.3 Stop of transmit/receive operation

● Note 1 (only transmission operation is stopped)

Clear the transmit enable bit to "0" (transmit disabled).

● Reason

Since transmission is not stopped and the transmission circuit is not initialized even if only the serial I/O enable bit is cleared to "0" (serial I/O disabled), the internal transmission is running (in this case, since pins TxD, RxD, SCLK, and $\overline{\text{SRDY}}$ function as I/O ports, the transmission data is not output). When data is written to the transmit buffer register in this state, data starts to be shifted to the transmit shift register. When the serial I/O enable bit is set to "1" at this time, the data during internally shifting is output to the TxD pin and an operation failure occurs.

● Note 2 (only receive operation is stopped)

Clear the receive enable bit to "0" (receive disabled).

3. $\overline{\text{SRDY}}$ output of reception side

● Note

When signals are output from the $\overline{\text{SRDY}}$ pin on the reception side by using an external clock in the clock synchronous serial I/O mode, set all of the receive enable bit, the $\overline{\text{SRDY}}$ output enable bit, and the transmit enable bit to "1" (transmit enabled).

4. Setting serial I/O control register again

● Note

Set the serial I/O control register again after the transmission and the reception circuits are reset by clearing both the transmit enable bit and the receive enable bit to "0."

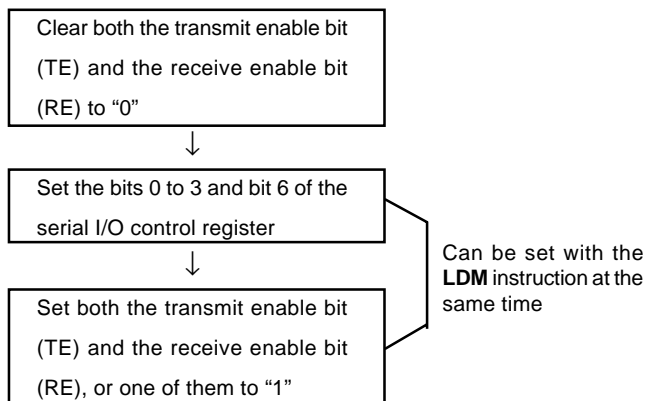

5. Data transmission control with referring to transmit shift register completion flag

● Note

The transmit shift register completion flag changes from "1" to "0" with a delay of 0.5 to 1.5 shift clocks. When data transmission is controlled with referring to the flag after writing the data to the transmit buffer register, note the delay.

6. Transmission control when external clock is selected

● Note

When an external clock is used as the synchronous clock for data transmission, set the transmit enable bit to "1" at "H" of the SCLK input level. Also, write data to the transmit buffer register at "H" of the SCLK input level.

7. Transmit interrupt request when transmit enable bit is set

● Note

When the transmit enable bit is set to "1", the transmit buffer empty flag and the transmit shift register completion flag are also set to "1". Therefore, regardless of selecting which timing for the generating of transmit interrupts, the interrupt request is generated and the transmit interrupt request bit is set at this point.

To use transmit interrupts, first set the transmit enable bit, then clear the transmit interrupt request bit to "0" and set the transmit interrupt enable bit to enabled.

Serial I/O2

The serial I/O2 function can be used only for clock synchronous serial I/O.

For clock synchronous serial I/O2, the transmitter and the receiver must use the same clock. If the internal clock is used, transfer is started by a write signal to the serial I/O2 register.

**[Serial I/O2 Control Register (SIO2CON)]
001D16**

The serial I/O2 control register contains eight bits which control various serial I/O functions.

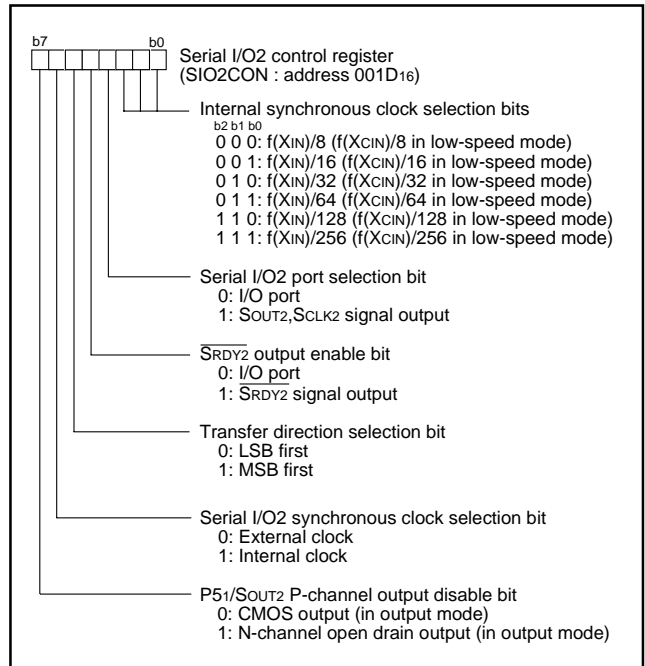

Fig. 43 Structure of serial I/O2 control register

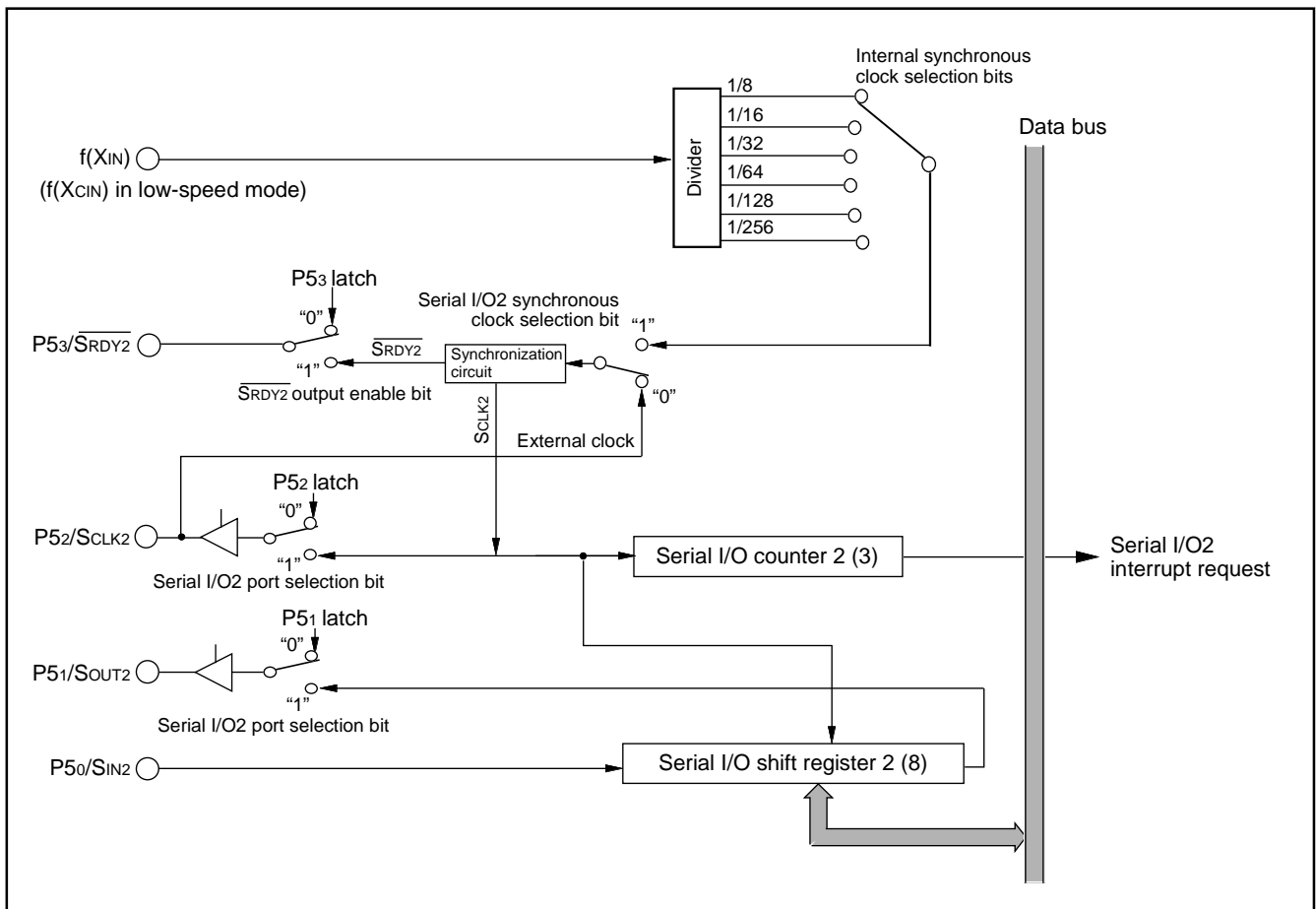

Fig. 44 Block diagram of serial I/O2

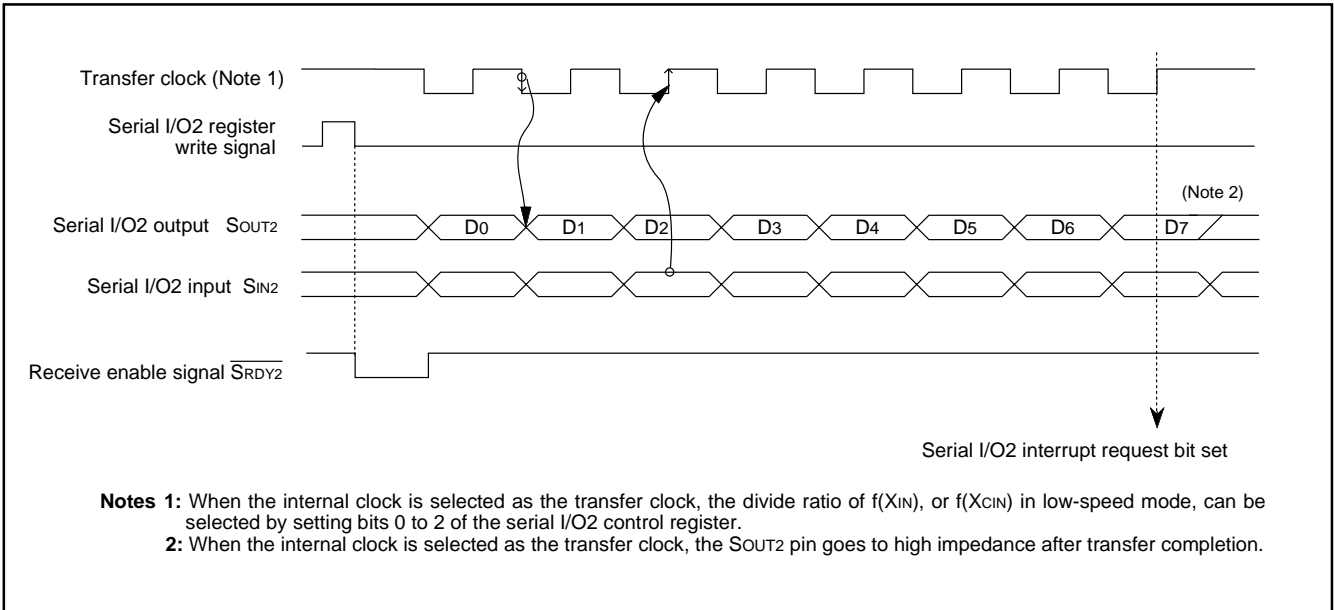

Fig. 45 Timing of serial I/O2

Serial I/O3

Serial I/O3 can be used as either clock synchronous or asynchronous (UART) serial I/O. A dedicated timer is also provided for baud rate generation.

(1) Clock Synchronous Serial I/O Mode

Clock synchronous serial I/O mode can be selected by setting the serial I/O3 mode selection bit of the serial I/O3 control register (bit 6 of address 0032₁₆) to "1".

For clock synchronous serial I/O, the transmitter and the receiver must use the same clock. If an internal clock is used, transfer is started by a write signal to the transmit/receive buffer register.

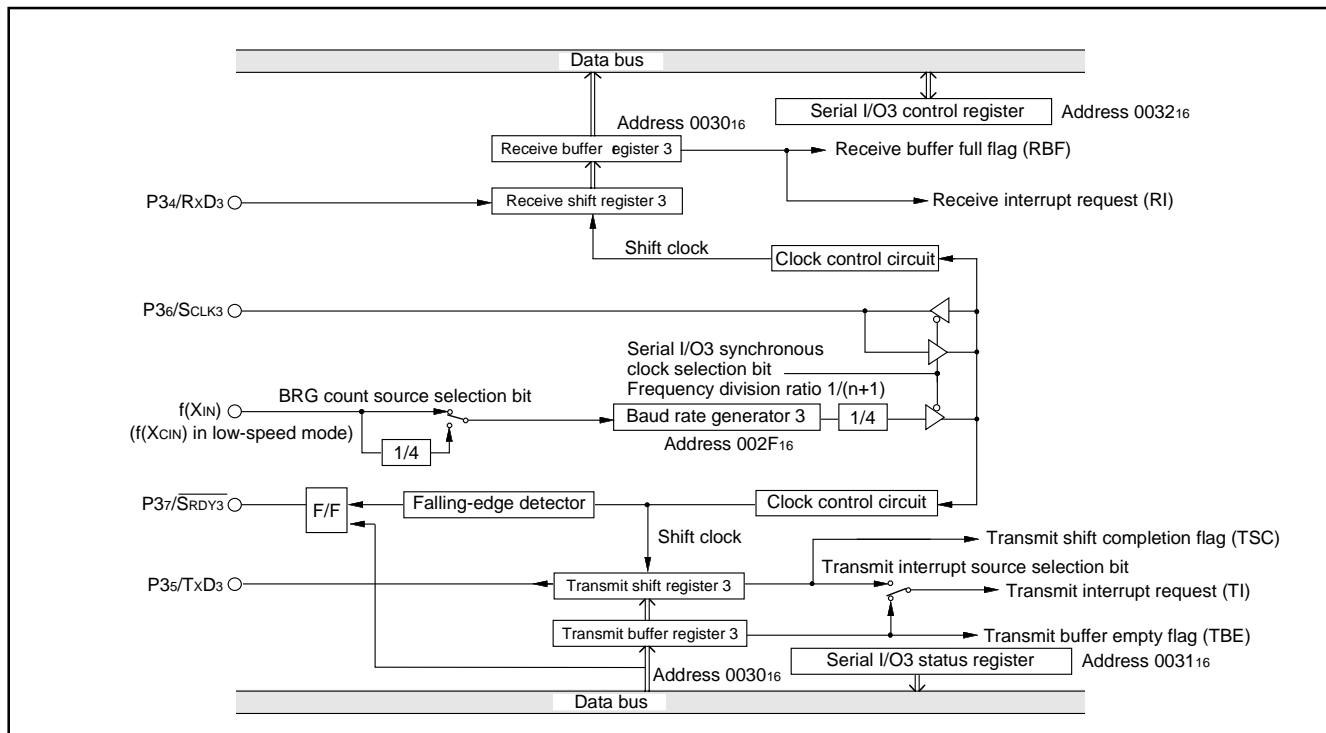

Fig. 46 Block diagram of clock synchronous serial I/O3

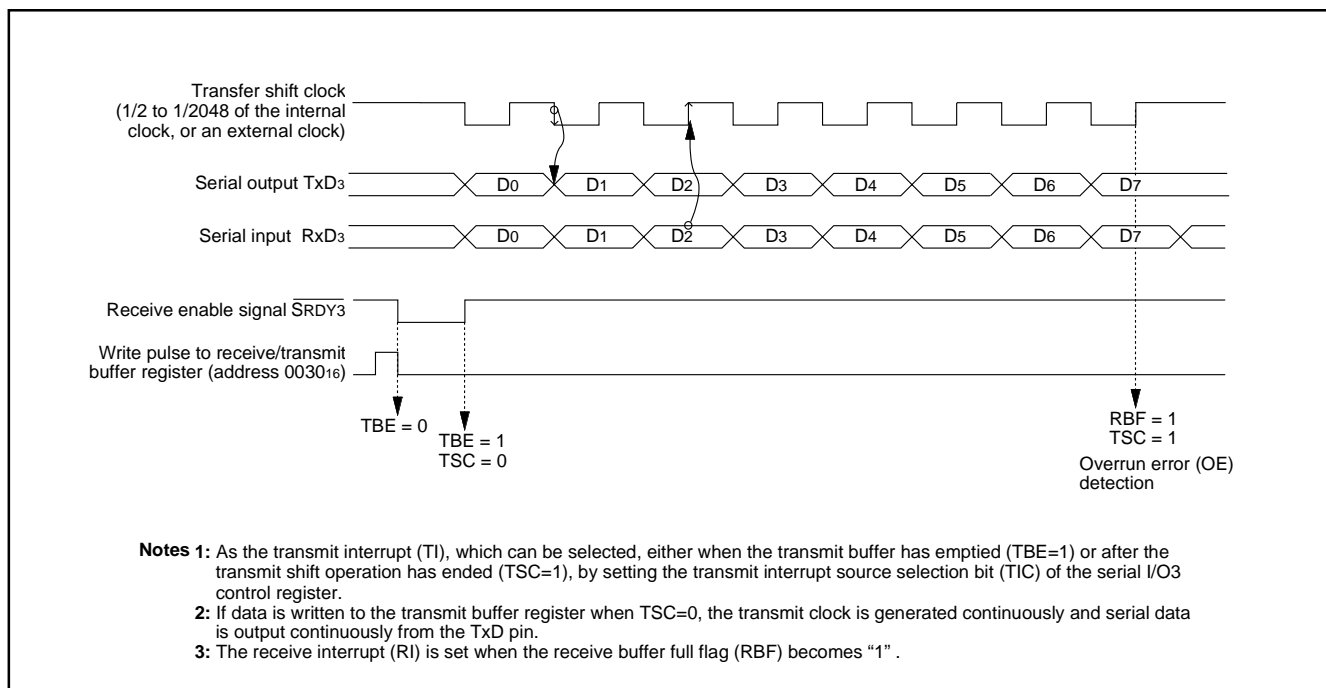

Fig. 47 Operation of clock synchronous serial I/O3

(2) Asynchronous Serial I/O (UART) Mode

Clock asynchronous serial I/O mode (UART) can be selected by clearing the serial I/O3 mode selection bit of the serial I/O3 control register to "0".

Eight serial data transfer formats can be selected, and the transfer formats used by a transmitter and receiver must be identical.

The transmit and receive shift registers each have a buffer, but the

two buffers have the same address in a memory. Since the shift register cannot be written to or read from directly, transmit data is written to the transmit buffer register, and receive data is read from the receive buffer register.

The transmit buffer register can also hold the next data to be transmitted, and the receive buffer register can hold a character while the next character is being received.

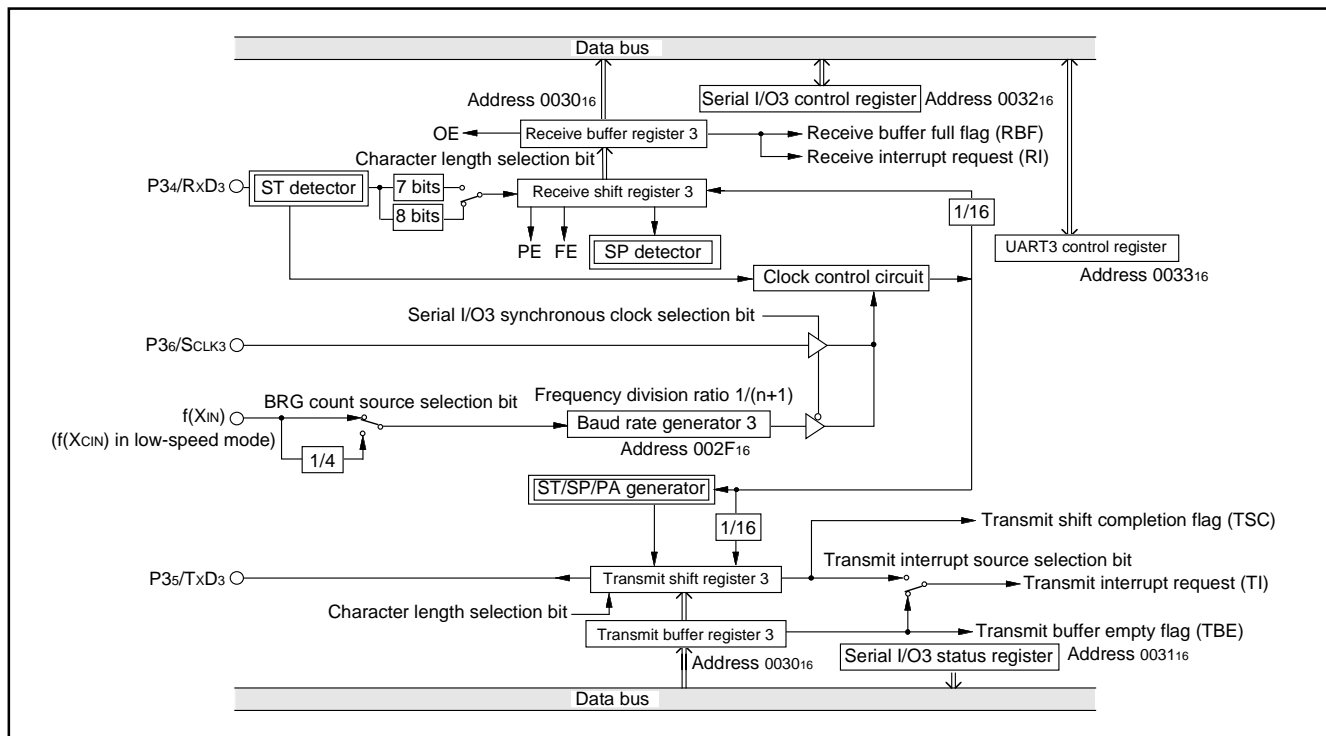
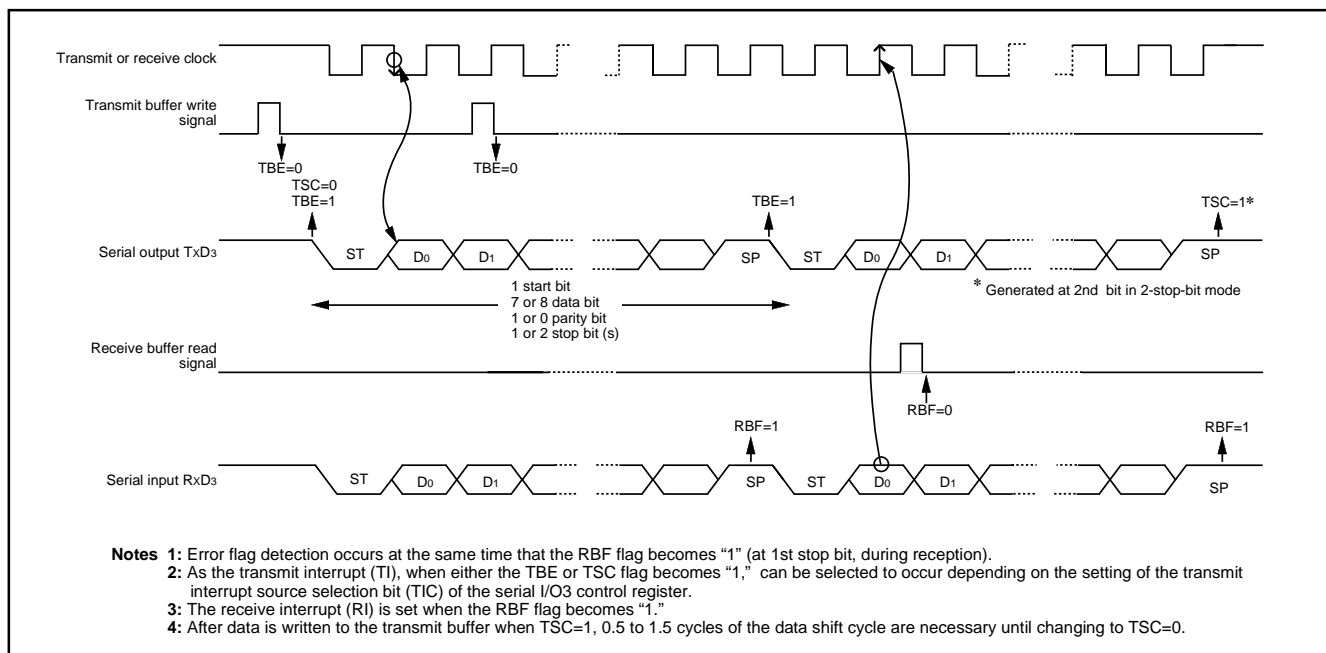

Fig. 48 Block diagram of UART serial I/O3



- Notes**
- 1: Error flag detection occurs at the same time that the RBF flag becomes "1" (at 1st stop bit, during reception).
 - 2: As the transmit interrupt (TI), when either the TBE or TSC flag becomes "1," can be selected to occur depending on the setting of the transmit interrupt source selection bit (TIC) of the serial I/O3 control register.
 - 3: The receive interrupt (RI) is set when the RBF flag becomes "1."
 - 4: After data is written to the transmit buffer when TSC=1, 0.5 to 1.5 cycles of the data shift cycle are necessary until changing to TSC=0.

Fig. 49 Operation of UART serial I/O3

[Serial I/O3 Control Register (SIO3CON)]
003216

The serial I/O3 control register consists of eight control bits for the serial I/O function.

[UART3 Control Register (UART3CON)]
003316

The UART control register consists of four control bits (bits 0 to 3) which are valid when asynchronous serial I/O is selected and set the data format of an data transfer, and one bit (bit 4) which is always valid and sets the output structure of the P35/TxD3 pin.

[Serial I/O3 Status Register (SIO3STS)] 003116

The read-only serial I/O3 status register consists of seven flags (bits 0 to 6) which indicate the operating status of the serial I/O3 function and various errors.

Three of the flags (bits 4 to 6) are valid only in UART mode.

The receive buffer full flag (bit 1) is cleared to "0" when the receive buffer register is read.

If there is an error, it is detected at the same time that data is transferred from the receive shift register to the receive buffer register, and the receive buffer full flag is set. A write to the serial I/O3 status register clears all the error flags OE, PE, FE, and SE (bit 3 to bit 6, respectively). Writing "0" to the serial I/O3 enable bit SIOE (bit 7 of the serial I/O3 control register) also clears all the status flags, including the error flags.

Bits 0 to 6 of the serial I/O3 status register are initialized to "0" at reset, but if the transmit enable bit (bit 4) of the serial I/O3 control register has been set to "1", the transmit shift completion flag (bit 2) and the transmit buffer empty flag (bit 0) become "1".

[Transmit Buffer Register 3/Receive Buffer Register 3 (TB3/RB3)] 003016

The transmit buffer register 3 and the receive buffer register 3 are located at the same address. The transmit buffer is write-only and the receive buffer is read-only. If a character bit length is 7 bits, the MSB of data stored in the receive buffer is "0".

[Baud Rate Generator 3 (BRG3)] 002F16

The baud rate generator determines the baud rate for serial transfer.

The baud rate generator divides the frequency of the count source by $1/(n + 1)$, where n is the value written to the baud rate generator.

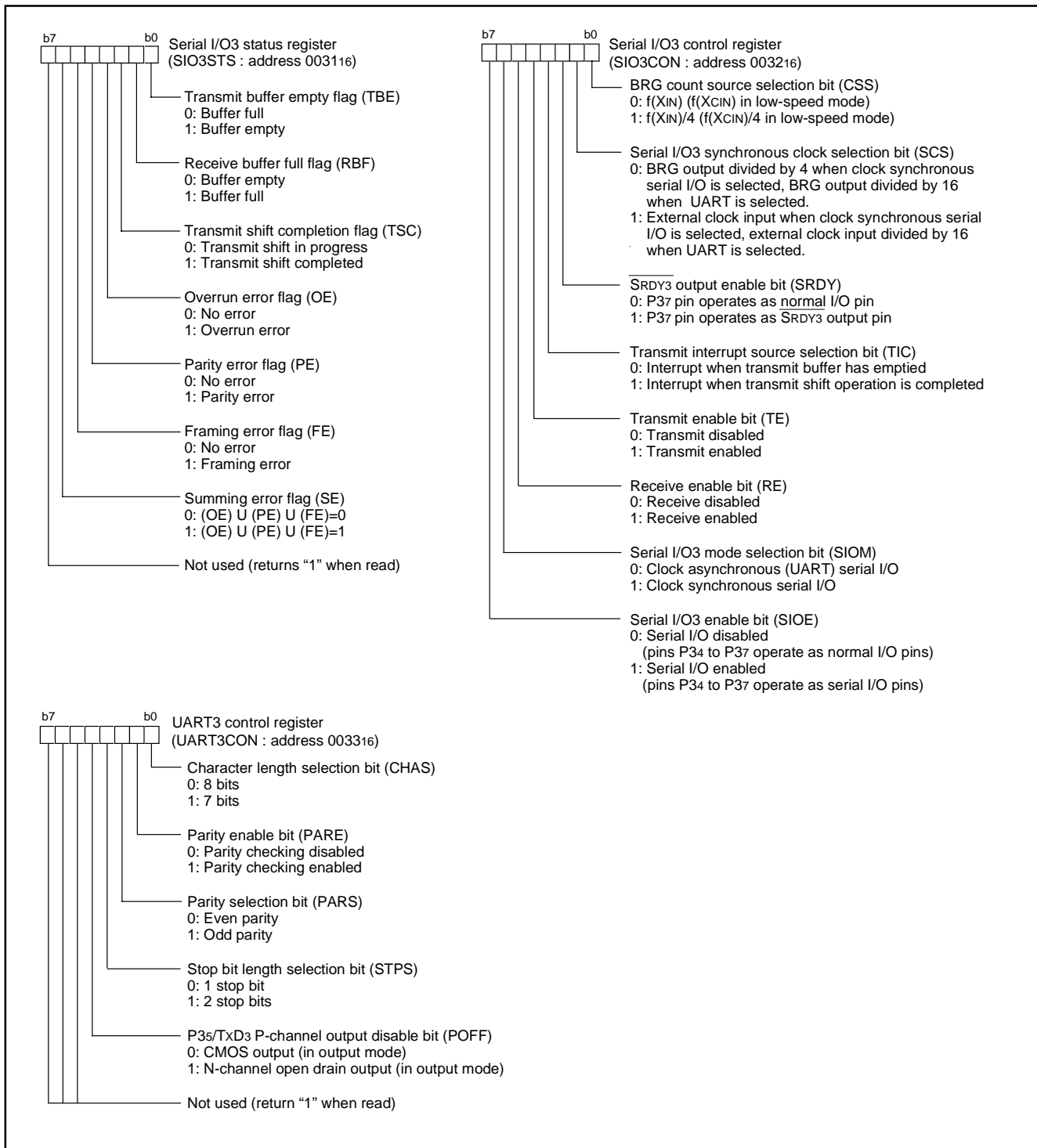

Fig. 50 Structure of serial I/O3 control registers

■ Notes concerning serial I/O3

1. Notes when selecting clock synchronous serial I/O

1.1 Stop of transmission operation

● Note

Clear the serial I/O enable bit and the transmit enable bit to "0" (serial I/O and transmit disabled).

● Reason

Since transmission is not stopped and the transmission circuit is not initialized even if only the serial I/O enable bit is cleared to "0" (serial I/O disabled), the internal transmission is running (in this case, since pins TxD, RxD, SCLK, and $\overline{\text{SRDY}}$ function as I/O ports, the transmission data is not output). When data is written to the transmit buffer register in this state, data starts to be shifted to the transmit shift register. When the serial I/O enable bit is set to "1" at this time, the data during internally shifting is output to the TxD pin and an operation failure occurs.

1.2 Stop of receive operation

● Note

Clear the receive enable bit to "0" (receive disabled), or clear the serial I/O enable bit to "0" (serial I/O disabled).

1.3 Stop of transmit/receive operation

● Note

Clear both the transmit enable bit and receive enable bit to "0" (transmit and receive disabled).
(when data is transmitted and received in the clock synchronous serial I/O mode, any one of data transmission and reception cannot be stopped.)

● Reason

In the clock synchronous serial I/O mode, the same clock is used for transmission and reception. If any one of transmission and reception is disabled, a bit error occurs because transmission and reception cannot be synchronized.

In this mode, the clock circuit of the transmission circuit also operates for data reception. Accordingly, the transmission circuit does not stop by clearing only the transmit enable bit to "0" (transmit disabled). Also, the transmission circuit is not initialized by clearing the serial I/O enable bit to "0" (serial I/O disabled) (refer to 1.1).

2. Notes when selecting clock asynchronous serial I/O

2.1 Stop of transmission operation

● Note

Clear the transmit enable bit to "0" (transmit disabled).

● Reason

Since transmission is not stopped and the transmission circuit is not initialized even if only the serial I/O enable bit is cleared to "0" (serial I/O disabled), the internal transmission is running (in this case, since pins TxD, RxD, SCLK, and $\overline{\text{SRDY}}$ function as I/O ports, the transmission data is not output). When data is written to the transmit buffer register in this state, data starts to be shifted to the transmit shift register. When the serial I/O enable bit is set to "1" at this time, the data during internally shifting is output to the TxD pin and an operation failure occurs.

2.2 Stop of receive operation

● Note

Clear the receive enable bit to "0" (receive disabled).

2.3 Stop of transmit/receive operation

● Note 1 (only transmission operation is stopped)

Clear the transmit enable bit to "0" (transmit disabled).

● Reason

Since transmission is not stopped and the transmission circuit is not initialized even if only the serial I/O enable bit is cleared to "0" (serial I/O disabled), the internal transmission is running (in this case, since pins TxD, RxD, SCLK, and $\overline{\text{SRDY}}$ function as I/O ports, the transmission data is not output). When data is written to the transmit buffer register in this state, data starts to be shifted to the transmit shift register. When the serial I/O enable bit is set to "1" at this time, the data during internally shifting is output to the TxD pin and an operation failure occurs.

● Note 2 (only receive operation is stopped)

Clear the receive enable bit to "0" (receive disabled).

3. $\overline{\text{SRDY}}$ output of reception side**● Note**

When signals are output from the $\overline{\text{SRDY}}$ pin on the reception side by using an external clock in the clock synchronous serial I/O mode, set all of the receive enable bit, the $\overline{\text{SRDY}}$ output enable bit, and the transmit enable bit to "1" (transmit enabled).

4. Setting serial I/O control register again**● Note**

Set the serial I/O control register again after the transmission and the reception circuits are reset by clearing both the transmit enable bit and the receive enable bit to "0."

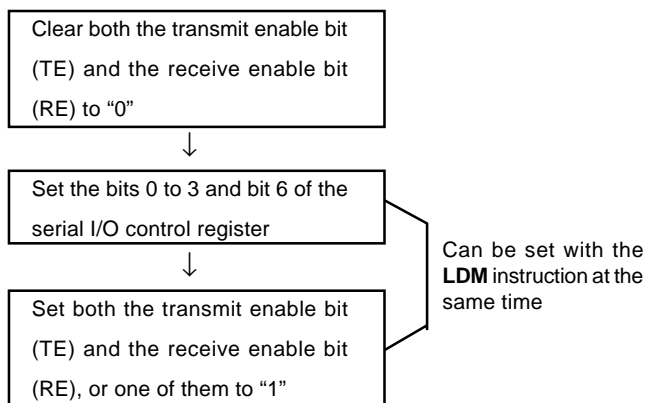
**5. Data transmission control with referring to transmit shift register completion flag****● Note**

The transmit shift register completion flag changes from "1" to "0" with a delay of 0.5 to 1.5 shift clocks. When data transmission is controlled with referring to the flag after writing the data to the transmit buffer register, note the delay.

6. Transmission control when external clock is selected**● Note**

When an external clock is used as the synchronous clock for data transmission, set the transmit enable bit to "1" at "H" of the SCLK input level. Also, write data to the transmit buffer register at "H" of the SCLK input level.

7. Transmit interrupt request when transmit enable bit is set**● Note**

When the transmit enable bit is set to "1", the transmit buffer empty flag and the transmit shift register completion flag are also set to "1". Therefore, regardless of selecting which timing for the generating of transmit interrupts, the interrupt request is generated and the transmit interrupt request bit is set at this point.

To use transmit interrupts, first set the transmit enable bit, then clear the transmit interrupt request bit to "0" and set the transmit interrupt enable bit to enabled.

PULSE WIDTH MODULATION (PWM)

The 3803/3804 group has PWM functions with an 8-bit resolution, based on a signal that is the clock input X_{IN} or that clock input divided by 2 or the clock input X_{CIN} or that clock input divided by 2 in low-speed mode.

Data Setting

The PWM output pin also functions as port P5₆. Set the PWM period by the PWM prescaler, and set the "H" term of output pulse by the PWM register.

If the value in the PWM prescaler is n and the value in the PWM register is m (where n = 0 to 255 and m = 0 to 255) :

$$\begin{aligned} \text{PWM period} &= 255 \times (n+1) / f(X_{IN}) \\ &= 31.875 \times (n+1) \mu\text{s} \quad (\text{when } f(X_{IN}) = 8 \text{ MHz}) \end{aligned}$$

$$\begin{aligned} \text{Output pulse "H" term} &= \text{PWM period} \times m / 255 \\ &= 0.125 \times (n+1) \times m \mu\text{s} \\ &\quad (\text{when } f(X_{IN}) = 8 \text{ MHz}) \end{aligned}$$

PWM Operation

When bit 0 (PWM enable bit) of the PWM control register is set to "1", operation starts by initializing the PWM output circuit, and pulses are output starting at an "H".

If the PWM register or PWM prescaler is updated during PWM output, the pulses will change in the cycle after the one in which the change was made.

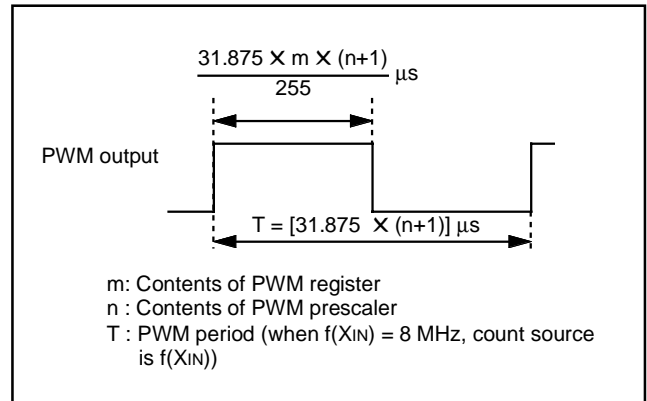

Fig. 51 Timing of PWM period

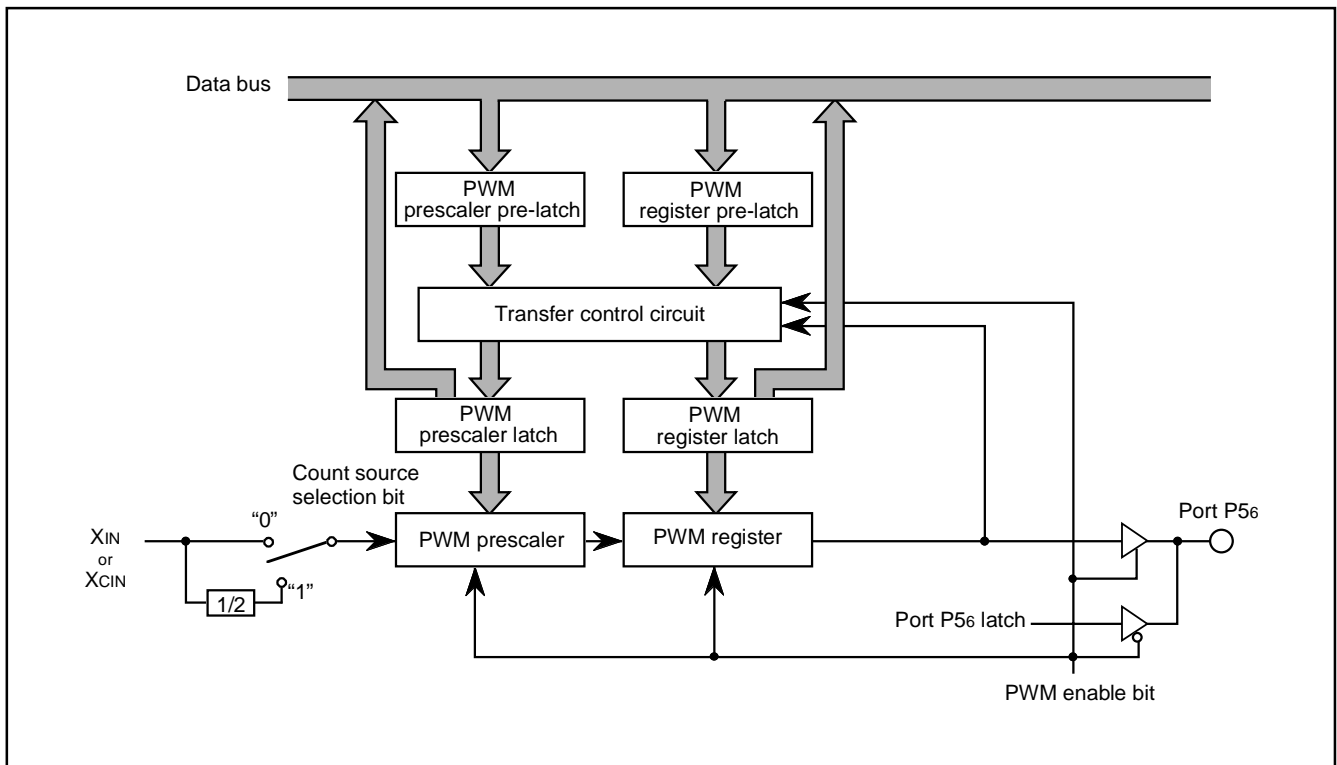

Fig. 52 Block diagram of PWM function

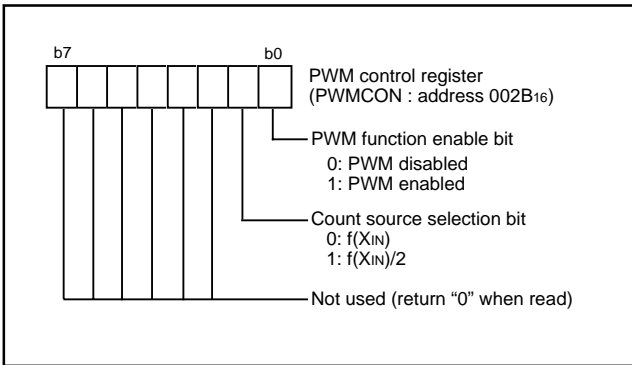

Fig. 53 Structure of PWM control register

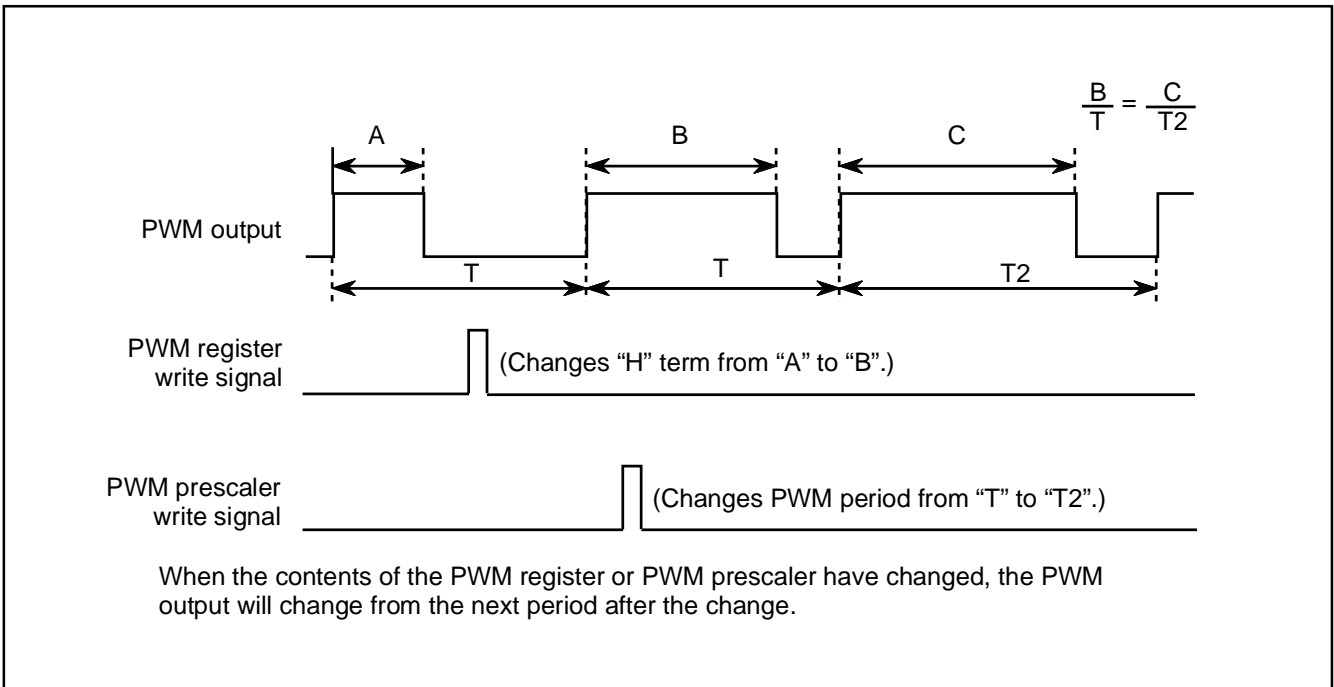

Fig. 54 PWM output timing when PWM register or PWM prescaler is changed

A-D CONVERTER

**[A-D Conversion Register 1, 2 (AD1, AD2)]
003516, 003816**

The A-D conversion register is a read-only register that stores the result of an A-D conversion. When reading this register during an A-D conversion, the previous conversion result is read.

Bit 7 of the A-D conversion register 2 is the conversion mode selection bit. When this bit is set to "0," the A-D converter becomes the 10-bit A-D mode. When this bit is set to "1," that becomes the 8-bit A-D mode. The conversion result of the 8-bit A-D mode is stored in the A-D conversion register 1. As for 10-bit A-D mode, not only 10-bit reading but also only high-order 8-bit reading of conversion result can be performed by selecting the reading procedure of the A-D conversion registers 1, 2 after A-D conversion is completed (in Figure 56).

As for 10-bit A-D mode, the 8-bit reading inclined to MSB is performed when reading the A-D converter register 1 after A-D conversion is started; and when the A-D converter register 1 is read after reading the A-D converter register 2, the 8-bit reading inclined to LSB is performed.

[AD/DA Control Register (ADCON)] 003416

The AD/DA control register controls the A-D conversion process. Bits 0 to 2 and bit 4 select a specific analog input pin. Bit 3 signals the completion of an A-D conversion. The value of this bit remains at "0" during an A-D conversion, and changes to "1" when an A-D conversion ends. Writing "0" to this bit starts the A-D conversion.

Comparison Voltage Generator

The comparison voltage generator divides the voltage between VREF and AVSS into 1024, and that outputs the comparison voltage in the 10-bit A-D mode (256 division in 8-bit A-D mode).

The A-D converter successively compares the comparison voltage Vref in each mode, dividing the VREF voltage (see below), with the input voltage.

- 10-bit A-D mode (10-bit reading)

$$V_{ref} = \frac{V_{REF}}{1024} \times n \quad (n = 0-1023)$$

- 10-bit A-D mode (8-bit reading)

$$V_{ref} = \frac{V_{REF}}{256} \times n \quad (n = 0-255)$$

- 8-bit A-D mode

$$V_{ref} = \frac{V_{REF}}{256} \times (n-0.5) \quad (n = 1-255)$$

$$= 0 \quad (n = 0)$$

Channel Selector

The channel selector selects one of ports P67/AN7 to P60/AN0 or P07/AN15 to P00/AN8, and inputs the voltage to the comparator.

Comparator and Control Circuit

The comparator and control circuit compares an analog input voltage with the comparison voltage, and then stores the result in the A-D conversion registers 1, 2. When an A-D conversion is completed, the control circuit sets the AD conversion completion bit and the AD interrupt request bit to "1".

Note that because the comparator consists of a capacitor coupling, set f(XIN) to 500 kHz or more during an A-D conversion.

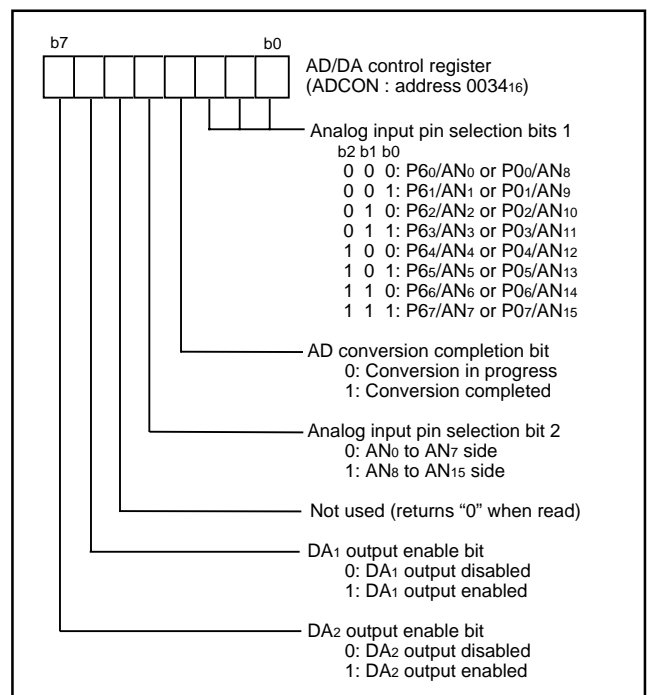

Fig. 55 Structure of AD/DA control register

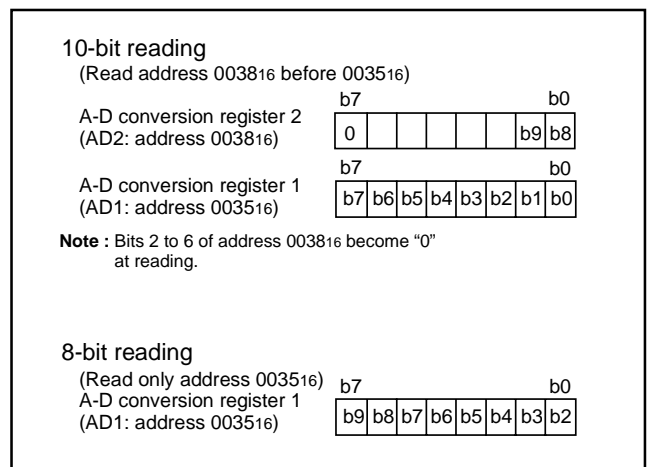

Fig. 56 Structure of 10-bit A-D mode reading

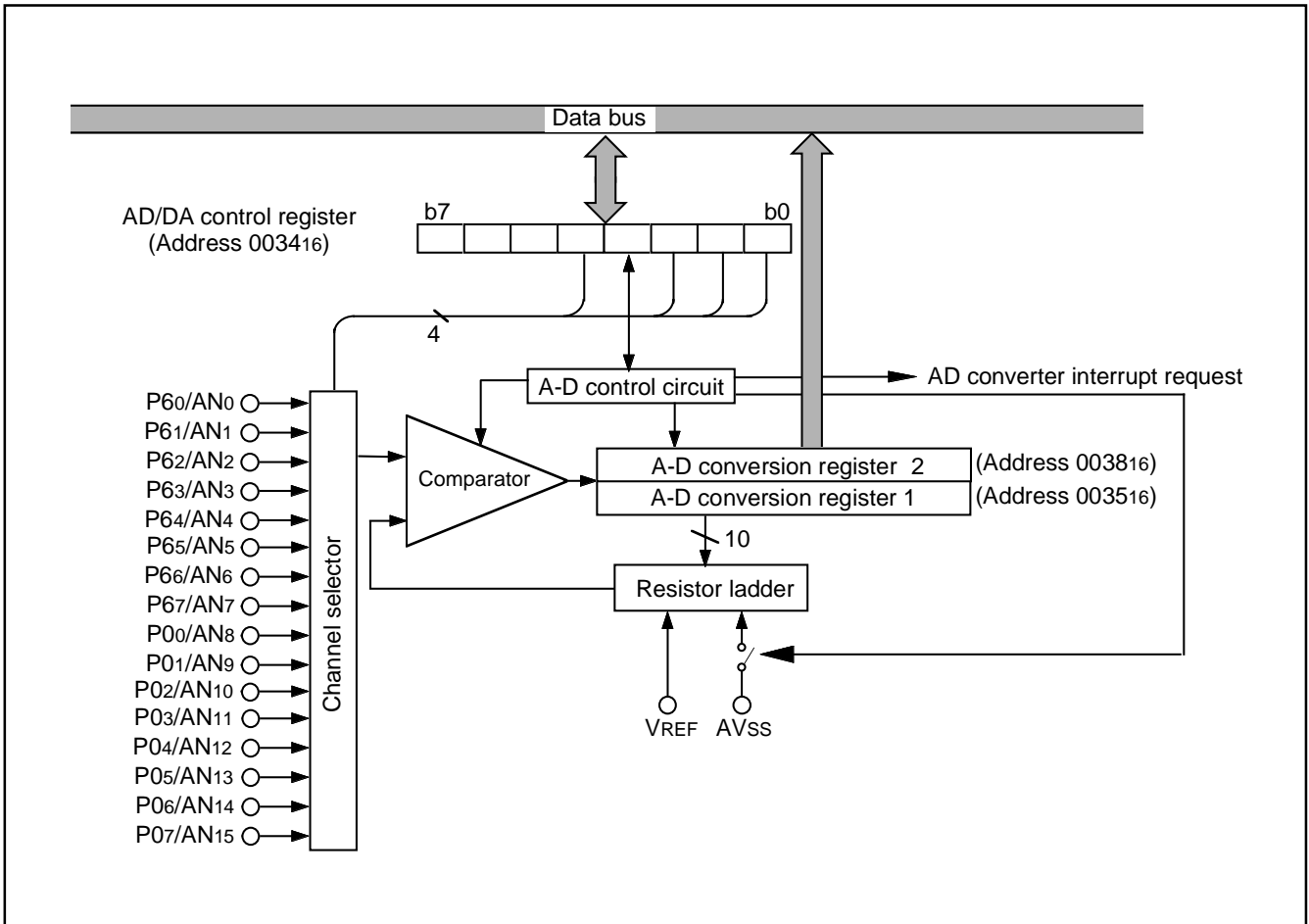

Fig. 57 Block diagram of A-D converter

D-A CONVERTER

The 3803/3804 group has two internal D-A converters (DA1 and DA2) with 8-bit resolution.

The D-A conversion is performed by setting the value in each D-A conversion register. The result of D-A conversion is output from the DA1 or DA2 pin by setting the DA output enable bit to "1".

When using the D-A converter, the corresponding port direction register bit (P30/DA1 or P31/DA2) must be set to "0" (input status). The output analog voltage V is determined by the value n (decimal notation) in the D-A conversion register as follows:

$$V = V_{REF} \times n/256 \quad (n = 0 \text{ to } 255)$$

Where VREF is the reference voltage.

At reset, the D-A conversion registers are cleared to "0016", and the DA output enable bits are cleared to "0", and the P30/DA1 and P31/DA2 pins become high impedance.

The DA output does not have buffers. Accordingly, connect an external buffer when driving a low-impedance load.

Set VCC to 3.0 V or more when using the D-A converter.

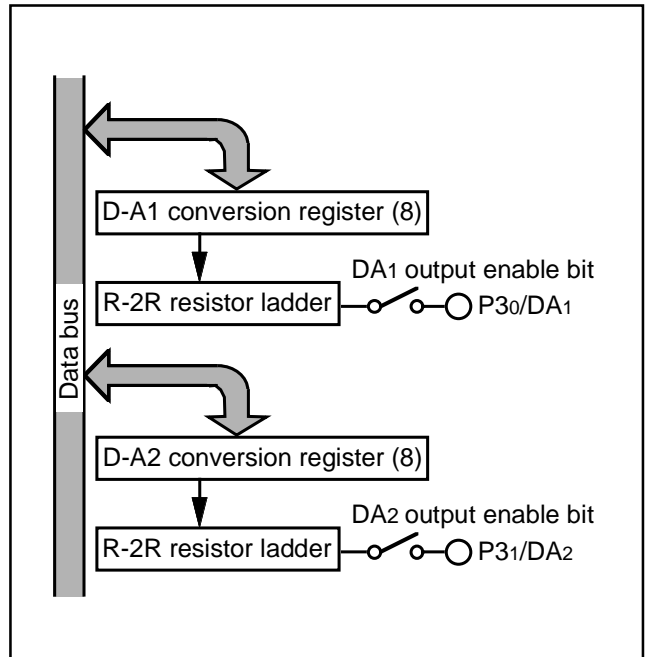

Fig. 58 Block diagram of D-A converter

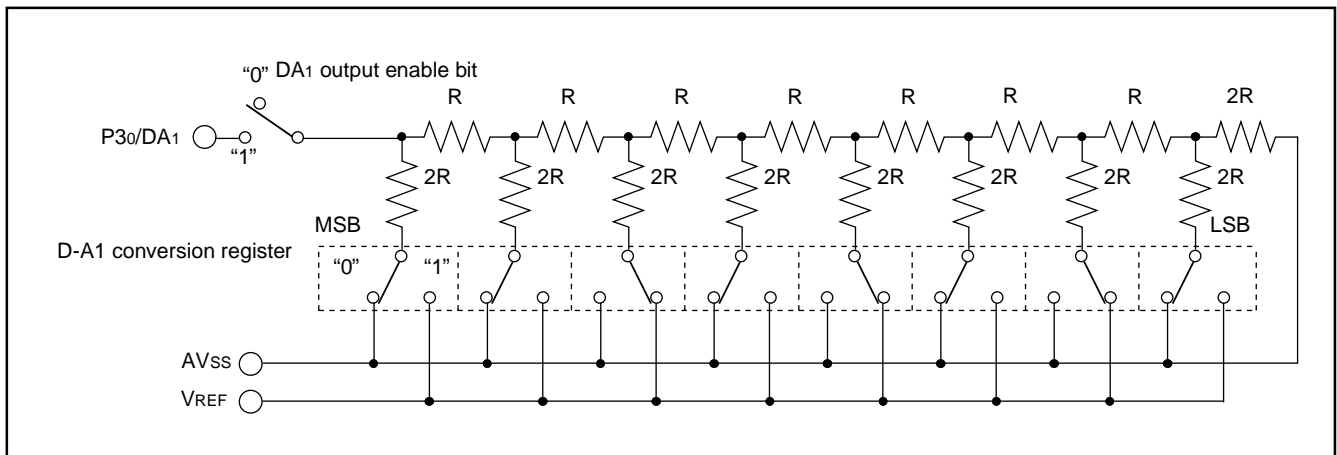

Fig. 59 Equivalent connection circuit of D-A converter (DA1)

WATCHDOG TIMER

The watchdog timer gives a mean of returning to the reset status when a program cannot run on a normal loop (for example, because of a software run-away). The watchdog timer consists of an 8-bit watchdog timer L and an 8-bit watchdog timer H.

Watchdog Timer Initial Value

Watchdog timer L is set to "FF16" and watchdog timer H is set to "FF16" by writing to the watchdog timer control register (address 001E16) or at a reset. Any write instruction that causes a write signal can be used, such as the STA, LDM, CLB, etc. Data can only be written to bits 6 and 7 of the watchdog timer control register. Regardless of the value written to bits 0 to 5, the above-mentioned value will be set to each timer.

Watchdog Timer Operations

The watchdog timer stops at reset and a countdown is started by the writing to the watchdog timer control register. An internal reset occurs when watchdog timer H underflows. The reset is released after its release time. After the release, the program is restarted from the reset vector address. Usually, write to the watchdog timer control register by software before an underflow of the watchdog timer H. The watchdog timer does not function if the watchdog timer control register is not written to at least once.

When bit 6 of the watchdog timer control register is kept at "0", the STP instruction is enabled. When that is executed, both the clock and the watchdog timer stop. Count re-starts at the same time as the release of stop mode (**Note**). The watchdog timer does not stop while a WIT instruction is executed. In addition, the STP instruction is disabled by writing "1" to this bit again. When the STP instruction is executed at this time, it is processed as an undefined instruction, and an internal reset occurs. Once a "1" is written to this bit, it cannot be programmed to "0" again.

The following shows the period between the write execution to the watchdog timer control register and the underflow of watchdog timer H.

Bit 7 of the watchdog timer control register is "0":
 when XCIN = 32.768 kHz; 32 s
 when XIN = 16 MHz; 65.536 ms

Bit 7 of the watchdog timer control register is "1":
 when XCIN = 32.768 kHz; 125 ms
 when XIN = 16 MHz; 256 μs

Note: The watchdog timer continues to count even while waiting for a stop release. Therefore, make sure that watchdog timer H does not underflow during this period.

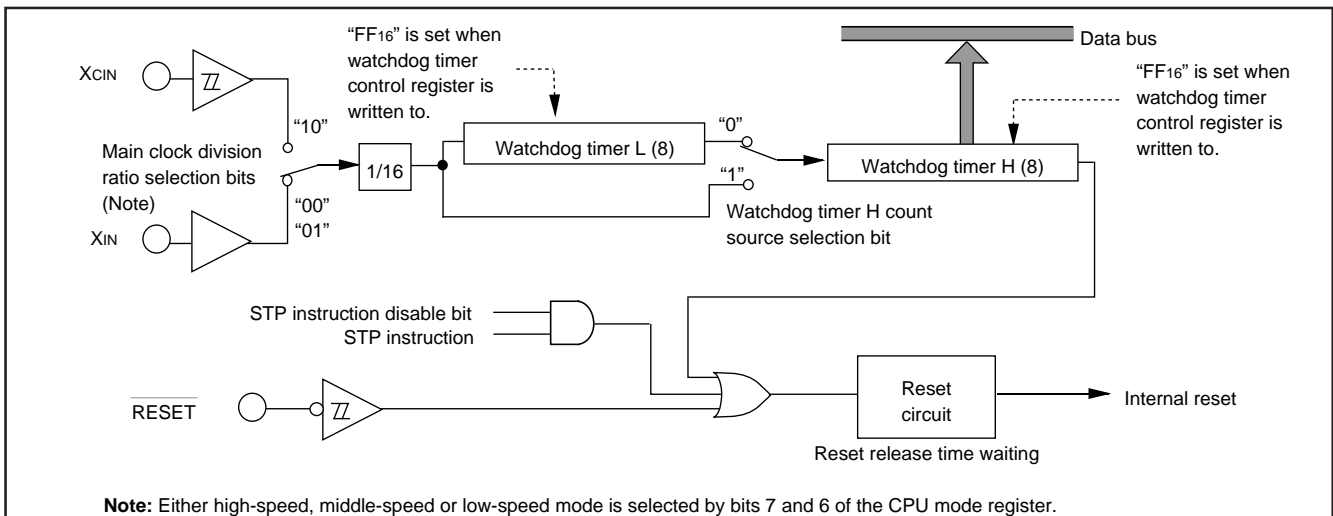

Fig. 60 Block diagram of Watchdog timer

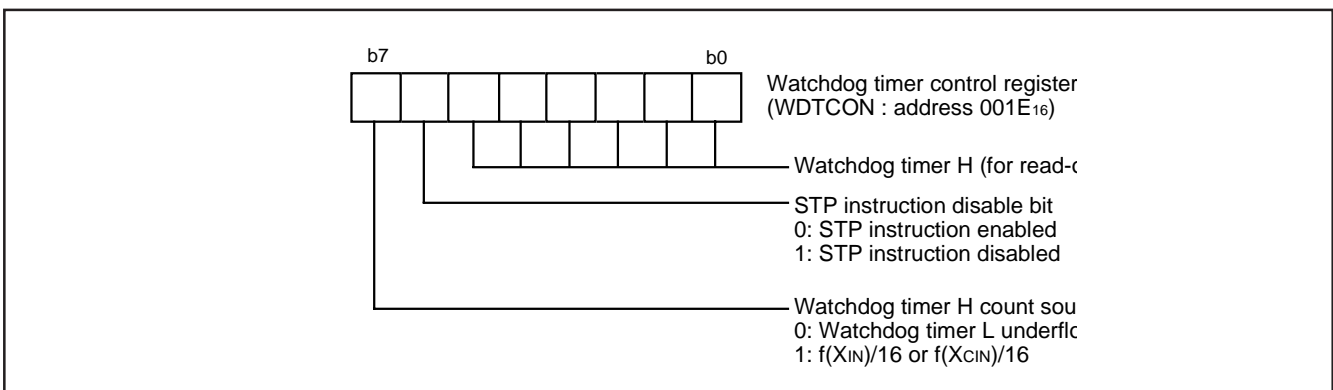

Fig. 61 Structure of Watchdog timer control register

MULTI-MASTER I²C-BUS INTERFACE

The 3804 group has the multi-master I²C-BUS interface. The multi-master I²C-BUS interface is a serial communications circuit, conforming to the Philips I²C-BUS data transfer format. This interface, offering both arbitration lost detection and a synchronous functions, is useful for the multi-master serial communications.

Figure 62 shows a block diagram of the multi-master I²C-BUS interface and Table 8 lists the multi-master I²C-BUS interface functions.

This multi-master I²C-BUS interface consists of the I²C slave address registers 0 to 2, the I²C data shift register, the I²C clock control register, the I²C control register, the I²C status register, the I²C START/STOP condition control register, the I²C special mode control register, the I²C special mode status register, and other control circuits.

When using the multi-master I²C-BUS interface, set 1 MHz or more to system clock ϕ .

Table 8 Multi-master I²C-BUS interface functions

Item	Function
Format	In conformity with Philips I ² C-BUS standard: 10-bit addressing format 7-bit addressing format High-speed clock mode Standard clock mode
Communication mode	In conformity with Philips I ² C-BUS standard: Master transmission Master reception Slave transmission Slave reception
SCL clock frequency	16.1 kHz to 400 kHz (at $\phi = 4$ MHz)

System clock $\phi = f(X_{IN})/2$ (high-speed mode)
 $\phi = f(X_{IN})/8$ (middle-speed mode)

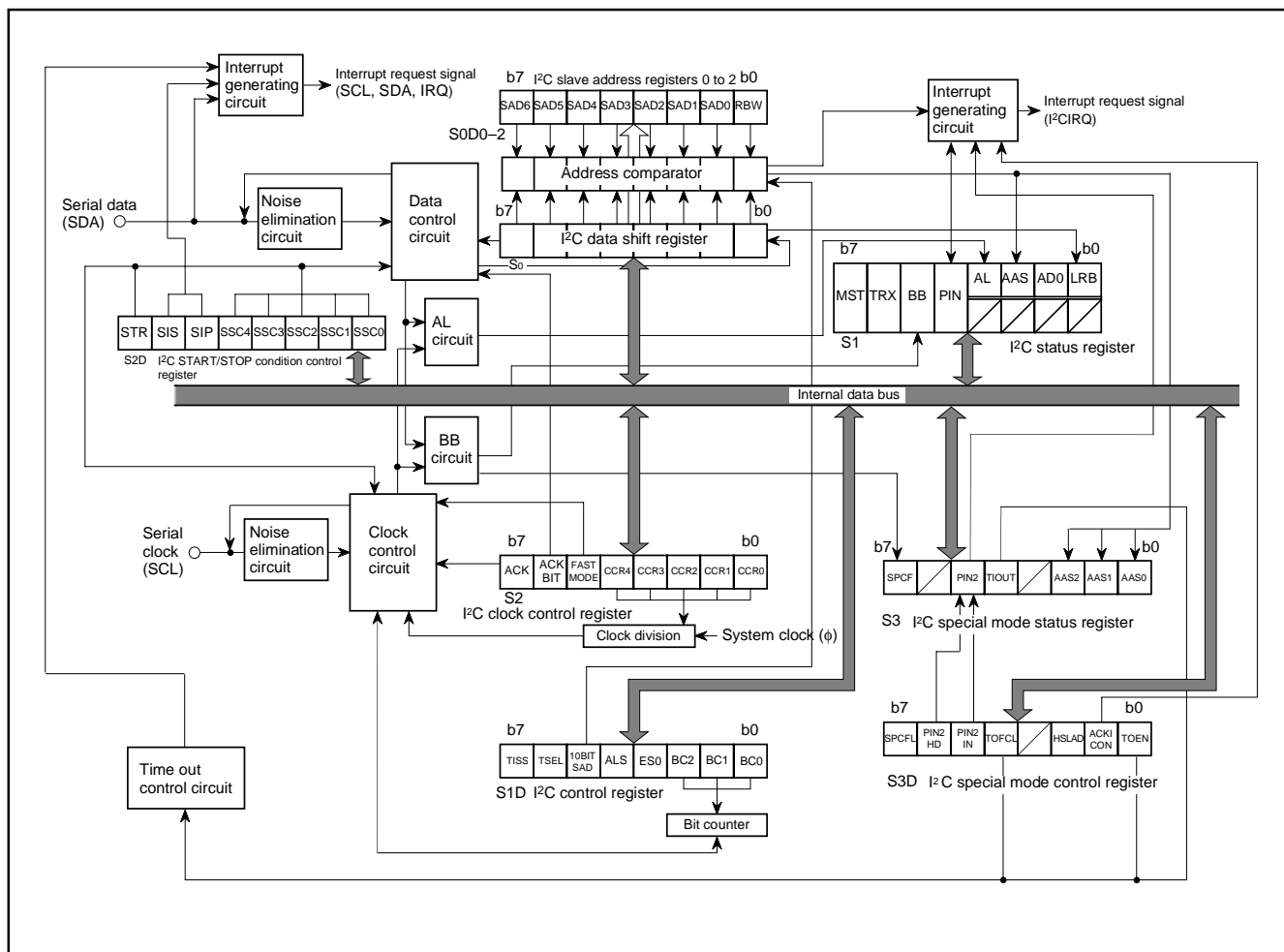

Fig. 62 Block diagram of multi-master I²C-BUS interface

* : Purchase of MITSUBISHI ELECTRIC CORPORATION'S I²C components conveys a license under the Philips I²C Patent Rights to use these components an I²C system, provided that the system conforms to the I²C Standard Specification as defined by Philips.

[I²C Data Shift Register (S0)] 001116

The I²C data shift register (S0: address 001116) is an 8-bit shift register to store receive data and write transmit data.

When transmit data is written into this register, it is transferred to the outside from bit 7 in synchronization with the SCL, and each time one-bit data is output, the data of this register are shifted by one bit to the left. When data is received, it is input to this register from bit 0 in synchronization with the SCL, and each time one-bit data is input, the data of this register are shifted by one bit to the left. The minimum 2 cycles of system clock ϕ are required from the rising of the SCL until input to this register.

The I²C data shift register is in a write enable status only when the I²C-BUS interface enable bit (ES0 bit) of the I²C control register (S1D: address 001416) is "1". The bit counter is reset by a write instruction to the I²C data shift register. When both the ES0 bit and the MST bit of the I²C status register (S1: address 001316) are "1," the SCL is output by a write instruction to the I²C data shift register. Reading data from the I²C data shift register is always enabled regardless of the ES0 bit value.

[I²C Slave Address Registers 0 to 2 (S0D0 to S0D2)] 0FF716 to 0FF916

The I²C slave address registers 0 to 2 (S0D0 to S0D2: addresses 0FF716 to 0FF916) consists of a 7-bit slave address and a read/write bit. In the addressing mode, the slave address written in this register is compared with the address data to be received immediately after the START condition is detected.

•Bit 0: Read/write bit (RWB)

This is not used in the 7-bit addressing mode. In the 10-bit addressing mode, the first address data to be received is compared with the contents (SAD6 to SAD0 + RWB) of the I²C slave address registers 0 to 2.

The RWB bit is cleared to "0" automatically when the stop condition is detected.

•Bits 1 to 7: Slave address (SAD0–SAD6)

These bits store slave addresses. Regardless of the 7-bit addressing mode or the 10-bit addressing mode, the address data transmitted from the master is compared with these bits' contents.

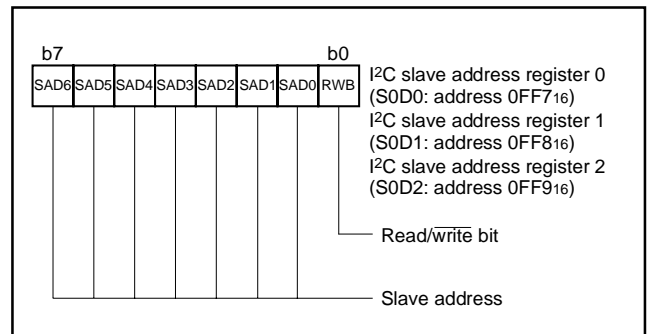

Fig. 63 Structure of I²C slave address registers 0 to 2

[I²C Clock Control Register (S2)] 001516

The I²C clock control register (S2: address 001516) is used to set ACK control, SCL mode and SCL frequency.

•Bits 0 to 4: SCL frequency control bits (CCR0–CCR4)

These bits control the SCL frequency. Refer to Table 9.

•Bit 5: SCL mode specification bit (FAST MODE)

This bit specifies the SCL mode. When this bit is set to “0,” the standard clock mode is selected. When the bit is set to “1,” the high-speed clock mode is selected.

When connecting the bus of the high-speed mode I²C bus standard (maximum 400 kbits/s), use 8 MHz or more oscillation frequency f(XIN) in the high-speed mode (2 division clock).

•Bit 6: ACK bit (ACK BIT)

This bit sets the SDA status when an ACK clock* is generated. When this bit is set to “0,” the ACK return mode is selected and SDA goes to “L” at the occurrence of an ACK clock. When the bit is set to “1,” the ACK non-return mode is selected. The SDA is held in the “H” status at the occurrence of an ACK clock.

However, when the slave address agree with the address data in the reception of address data at ACK BIT = “0,” the SDA is automatically made “L” (ACK is returned). If there is a disagreement between the slave address and the address data, the SDA is automatically made “H” (ACK is not returned).

*ACK clock: Clock for acknowledgment

•Bit 7: ACK clock bit (ACK)

This bit specifies the mode of acknowledgment which is an acknowledgment response of data transfer. When this bit is set to “0,” the no ACK clock mode is selected. In this case, no ACK clock occurs after data transmission. When the bit is set to “1,” the ACK clock mode is selected and the master generates an ACK clock each completion of each 1-byte data transfer. The device for transmitting address data and control data releases the SDA at the occurrence of an ACK clock (makes SDA “H”) and receives the ACK bit generated by the data receiving device.

Note: Do not write data into the I²C clock control register during transfer. If data is written during transfer, the I²C clock generator is reset, so that data cannot be transferred normally.

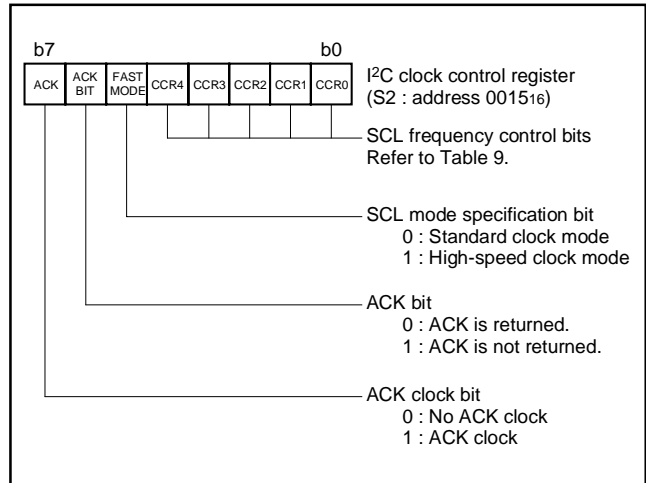

Fig. 64 Structure of I²C clock control register

Table 9 Set values of I²C clock control register and SCL frequency

Setting value of CCR4–CCR0					SCL frequency (at $\phi = 4$ MHz, unit : kHz) (Note 1)	
CCR4	CCR3	CCR2	CCR1	CCR0	Standard clock mode	High-speed clock mode
0	0	0	0	0	Setting disabled	Setting disabled
0	0	0	0	1	Setting disabled	Setting disabled
0	0	0	1	0	Setting disabled	Setting disabled
0	0	0	1	1	– (Note 2)	333
0	0	1	0	0	– (Note 2)	250
0	0	1	0	1	100	400 (Note 3)
0	0	1	1	0	83.3	166
:	:	:	:	:	500/CCR value (Note 3)	1000/CCR value (Note 3)
1	1	1	0	1	17.2	34.5
1	1	1	1	0	16.6	33.3
1	1	1	1	1	16.1	32.3

Notes 1: Duty of SCL output is 50 %. The duty becomes 35 to 45 % only when the high-speed clock mode is selected and CCR value = 5 (400 kHz, at $\phi = 4$ MHz). “H” duration of the clock fluctuates from –4 to +2 machine cycles in the standard clock mode, and fluctuates from –2 to +2 machine cycles in the high-speed clock mode. In the case of negative fluctuation, the frequency does not increase because “L” duration is extended instead of “H” duration reduction.

These are values when SCL synchronization by the synchronous function is not performed. CCR value is the decimal notation value of the SCL frequency control bits CCR4 to CCR0.

2: Each value of SCL frequency exceeds the limit at $\phi = 4$ MHz or more. When using these setting value, use ϕ of 4 MHz or less.

3: The data formula of SCL frequency is described below:
 $\phi / (8 \times \text{CCR value})$ Standard clock mode
 $\phi / (4 \times \text{CCR value})$ High-speed clock mode (CCR value $\neq 5$)
 $\phi / (2 \times \text{CCR value})$ High-speed clock mode (CCR value = 5)
 Do not set 0 to 2 as CCR value regardless of ϕ frequency.
 Set 100 kHz (max.) in the standard clock mode and 400 kHz (max.) in the high-speed clock mode to the SCL frequency by setting the SCL frequency control bits CCR4 to CCR0.

[I²C Control Register (S1D)] 0014₁₆

The I²C control register (S1D: address 0014₁₆) controls data communication format.

•Bits 0 to 2: Bit counter (BC0–BC2)

These bits decide the number of bits for the next 1-byte data to be transmitted. The I²C interrupt request signal occurs immediately after the number of count specified with these bits (ACK clock is added to the number of count when ACK clock is selected by ACK clock bit (bit 7 of S2, address 0015₁₆) have been transferred, and BC0 to BC2 are returned to "0002".

Also when a START condition is received, these bits become "0002" and the address data is always transmitted and received in 8 bits.

•Bit 3: I²C interface enable bit (ES0)

This bit enables to use the multi-master I²C-BUS interface. When this bit is set to "0," the use disable status is provided, so that the SDA and the SCL become high-impedance. When the bit is set to "1," use of the interface is enabled.

When ES0 = "0," the following is performed.

- PIN = "1," BB = "0" and AL = "0" are set (which are bits of the I²C status register, S1, at address 0013₁₆).

- Writing data to the I²C data shift register (S0: address 0011₁₆) is disabled.

•Bit 4: Data format selection bit (ALS)

This bit decides whether or not to recognize slave addresses. When this bit is set to "0," the addressing format is selected, so that address data is recognized. When a match is found between a slave address and address data as a result of comparison or when a general call (refer to "I²C Status Register," bit 1) is received, transfer processing can be performed. When this bit is set to "1," the free data format is selected, so that slave addresses are not recognized.

•Bit 5: Addressing format selection bit (10BIT SAD)

This bit selects a slave address specification format. When this bit is set to "0," the 7-bit addressing format is selected. In this case, only the high-order 7 bits (slave address) of the I²C slave address registers 0 to 2 are compared with address data. When this bit is set to "1," the 10-bit addressing format is selected, and all the bits of the I²C slave address registers 0 to 2 are compared with address data.

•Bit 7: I²C-BUS interface pin input level selection bit

This bit selects the input level of the SCL and SDA pins of the multi-master I²C-BUS interface.

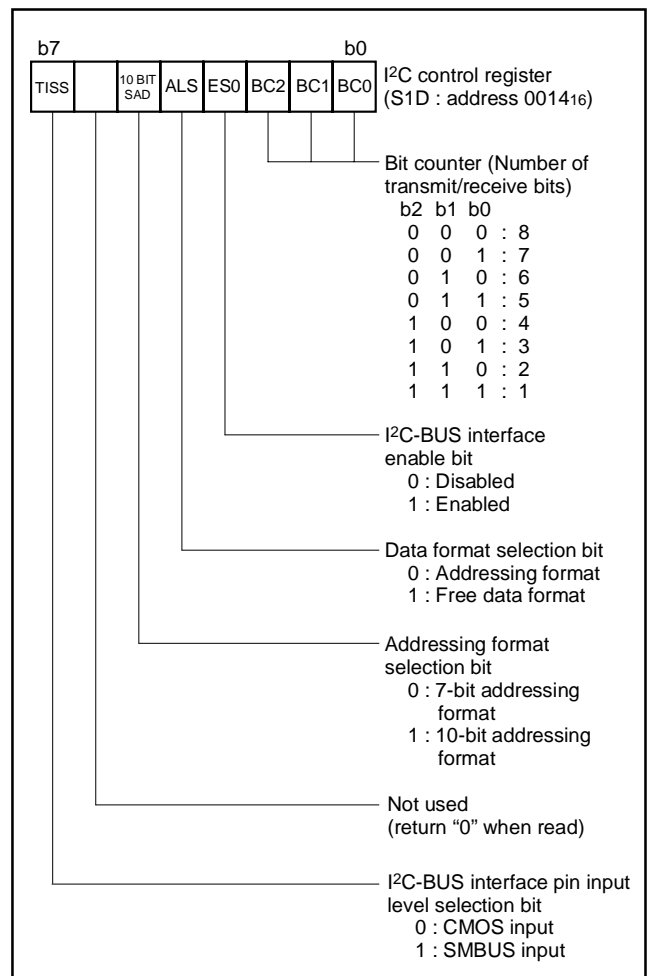

Fig. 65 Structure of I²C control register

[I²C Status Register (S1)] 001316

The I²C status register (S1: address 001316) controls the I²C-BUS interface status. The low-order 4 bits are read-only bits and the high-order 4 bits can be read out and written to.

Set "00002" to the low-order 4 bits, because these bits become the reserved bits at writing.

•Bit 0: Last receive bit (LRB)

This bit stores the last bit value of received data and can also be used for ACK receive confirmation. If ACK is returned when an ACK clock occurs, the LRB bit is set to "0." If ACK is not returned, this bit is set to "1." Except in the ACK mode, the last bit value of received data is input. The state of this bit is changed from "1" to "0" by executing a write instruction to the I²C data shift register (S0: address 001116).

•Bit 1: General call detecting flag (AD0)

When the ALS bit is "0", this bit is set to "1" when a general call* whose address data is all "0" is received in the slave mode. By a general call of the master device, every slave device receives control data after the general call. The AD0 bit is set to "0" by detecting the STOP condition or START condition, or reset.

*General call: The master transmits the general call address "0016" to all slaves.

•Bit 2: Slave address comparison flag (AAS)

This flag indicates a comparison result of address data when the ALS bit is "0".

① In the slave receive mode, when the 7-bit addressing format is selected, this bit is set to "1" in one of the following conditions:

- The address data immediately after occurrence of a START condition agrees with the slave address stored in the high-order 7 bits of the I²C slave address register.
- A general call is received.

② In the slave receive mode, when the 10-bit addressing format is selected, this bit is set to "1" with the following condition:

- When the address data is compared with the I²C slave address register (8 bits consisting of slave address and RBW bit), the first bytes agree.

③ This bit is set to "0" by executing a write instruction to the I²C data shift register (S0: address 001116) when ES0 is set to "1" or reset.

•Bit 3: Arbitration lost* detecting flag (AL)

In the master transmission mode, when the SDA is made "L" by any other device, arbitration is judged to have been lost, so that this bit is set to "1." At the same time, the TRX bit is set to "0," so that immediately after transmission of the byte whose arbitration was lost is completed, the MST bit is set to "0." The arbitration lost can be detected only in the master transmission mode. When arbitration is lost during slave address transmission, the TRX bit is set to "0" and the reception mode is set. Consequently, it becomes possible to detect the agreement of its own slave address and address data transmitted by another master device.

*Arbitration lost: The status in which communication as a master is disabled.

•Bit 4: SCL pin low hold bit (PIN)

This bit generates an interrupt request signal. Each time 1-byte data is transmitted, the PIN bit changes from "1" to "0." At the same time, an interrupt request signal occurs to the CPU. The PIN bit is set to "0" in synchronization with a falling of the last clock (including the ACK clock) of an internal clock and an interrupt request signal occurs in synchronization with a falling of the PIN bit. When the PIN bit is "0," the SCL is kept in the "0" state and clock generation is disabled. Figure 67 shows an interrupt request signal generating timing chart.

The PIN bit is set to "1" in one of the following conditions:

- Executing a write instruction to the I²C data shift register (S0: address 001116). (This is the only condition which the prohibition of the internal clock is released and data can be communicated except for the start condition detection.)
- When the ES0 bit is "0"
- At reset

• When writing "1" to the PIN bit by software

The PIN bit is set to "0" in one of the following conditions:

- Immediately after completion of 1-byte data transmission (including when arbitration lost is detected)
- Immediately after completion of 1-byte data reception
- In the slave reception mode, with ALS = "0" and immediately after completion of slave address agreement or general call address reception
- In the slave reception mode, with ALS = "1" and immediately after completion of address data reception

•Bit 5: Bus busy flag (BB)

This bit indicates the status of use of the bus system. When this bit is set to "0," this bus system is not busy and a START condition can be generated. The BB flag is set/reset by the SCL, SDA pins input signal regardless of master/slave. This flag is set to "1" by detecting the START condition, and is set to "0" by detecting the STOP condition. The condition of these detecting is set by the START/STOP condition setting bits (SSC4–SSC0) of the I²C START/STOP condition control register (S2D: address 001616). When the ES0 bit of the I²C control register (bit 3 of S1D, address 001416) is "0" or reset, the BB flag is set to "0."

For the writing function to the BB flag, refer to the sections "START Condition Generating Method" and "STOP Condition Generating Method" described later.

•Bit 6: Communication mode specification bit (transfer direction specification bit: TRX)

This bit decides a direction of transfer for data communication. When this bit is "0," the reception mode is selected and the data of a transmitting device is received. When the bit is "1," the transmission mode is selected and address data and control data are output onto the SDA in synchronization with the clock generated on the SCL.

This bit is set/reset by software and hardware. About set/reset by hardware is described below. This bit is set to "1" by hardware when all the following conditions are satisfied:

- When ALS is "0"
- In the slave reception mode or the slave transmission mode
- When the R/W bit reception is "1"

This bit is set to "0" in one of the following conditions:

- When arbitration lost is detected.
- When a STOP condition is detected.
- When writing "1" to this bit by software is invalid by the START condition duplication preventing function (**Note**).
- With MST = "0" and when a START condition is detected.
- With MST = "0" and when ACK non-return is detected.
- At reset

•Bit 7: Communication mode specification bit (master/slave specification bit: MST)

This bit is used for master/slave specification for data communication. When this bit is "0," the slave is specified, so that a START condition and a STOP condition generated by the master are received, and data communication is performed in synchronization with the clock generated by the master. When this bit is "1," the master is specified and a START condition and a STOP condition are generated. Additionally, the clocks required for data communication are generated on the SCL.

This bit is set to "0" in one of the following conditions.

- Immediately after completion of 1-byte data transfer when arbitration lost is detected
- When a STOP condition is detected.
- Writing "1" to this bit by software is invalid by the START condition duplication preventing function (**Note**).
- At reset

Note: START condition duplication preventing function

The MST, TRX, and BB bits is set to "1" at the same time after confirming that the BB flag is "0" in the procedure of a START condition occurrence. However, when a START condition by another master device occurs and the BB flag is set to "1" immediately after the contents of the BB flag is confirmed, the START condition duplication preventing function makes the writing to the MST and TRX bits invalid. The duplication preventing function becomes valid from the rising of the BB flag to reception completion of slave address.

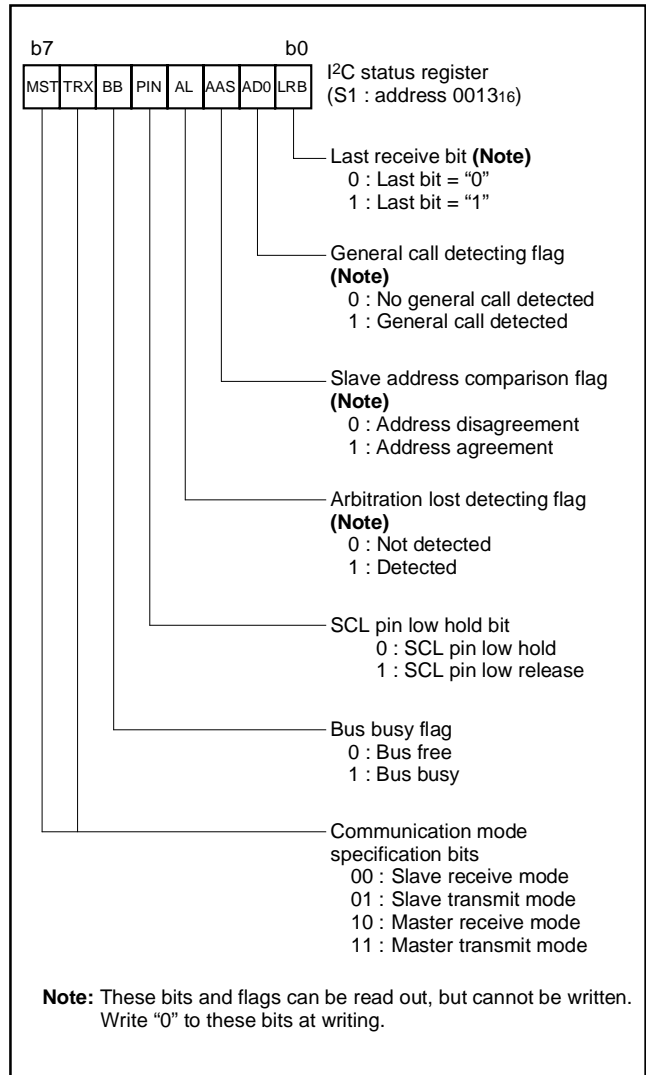

Fig. 66 Structure of I²C status register

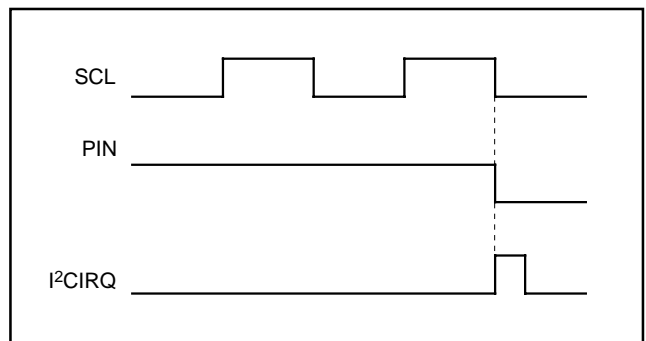

Fig. 67 Interrupt request signal generating timing

START Condition Generating Method

When writing "1" to the MST, TRX, and BB bits of the I²C status register (S1: address 0013₁₆) at the same time after writing the slave address to the I²C data shift register (S0: address 0011₁₆) with the condition in which the ES0 bit of the I²C control register (S1D: address 0014₁₆) and the BB flag are "0", a START condition occurs. After that, the bit counter becomes "0002" and an SCL for 1 byte is output. The START condition generating timing is different in the standard clock mode and the high-speed clock mode. Refer to Figure 68, the START condition generating timing diagram, and Table 10, the START condition generating timing table.

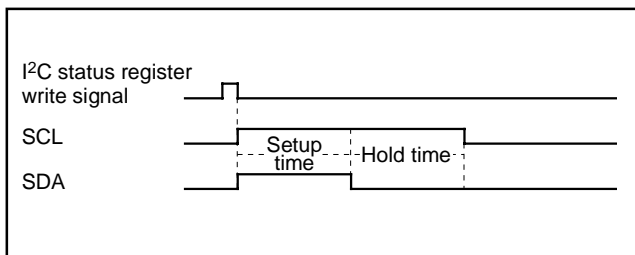

Fig. 68 START condition generating timing diagram

Table 10 START condition generating timing table

Item	Standard clock mode	High-speed clock mode
Setup time	5.0 μs (20 cycles)	2.5 μs (10 cycles)
Hold time	5.0 μs (20 cycles)	2.5 μs (10 cycles)

Note: Absolute time at φ = 4 MHz. The value in parentheses denotes the number of φ cycles.

STOP Condition Generating Method

When the ES0 bit of the I²C control register (S1D: address 0014₁₆) is "1," write "1" to the MST and TRX bits, and write "0" to the BB bit of the I²C status register (S1: address 0013₁₆) simultaneously. Then a STOP condition occurs. The STOP condition generating timing is different in the standard clock mode and the high-speed clock mode. Refer to Figure 69, the STOP condition generating timing diagram, and Table 11, the STOP condition generating timing table.

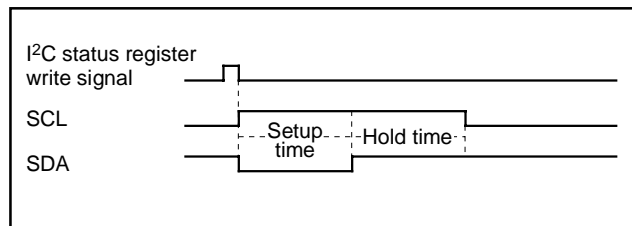

Fig. 69 STOP condition generating timing diagram

Table 11 STOP condition generating timing table

Item	Standard clock mode	High-speed clock mode
Setup time	5.0 μs (20 cycles)	3.0 μs (12 cycles)
Hold time	4.5 μs (18 cycles)	2.5 μs (10 cycles)

Note: Absolute time at φ = 4 MHz. The value in parentheses denotes the number of φ cycles.

START/STOP Condition Detecting Operation

The START/STOP condition detection operations are shown in Figures 70, 71, and Table 12. The START/STOP condition is set by the START/STOP condition set bit.

The START/STOP condition can be detected only when the input signal of the SCL and SDA pins satisfy three conditions: SCL release time, setup time, and hold time (see Table 12).

The BB flag is set to "1" by detecting the START condition and is reset to "0" by detecting the STOP condition.

The BB flag set/reset timing is different in the standard clock mode and the high-speed clock mode. Refer to Table 12, the BB flag set/reset time.

Note: When a STOP condition is detected in the slave mode (MST = 0), an interrupt request signal "I²CIRQ" occurs to the CPU.

Table 12 START condition/STOP condition detecting conditions

	Standard clock mode	High-speed clock mode
SCL release time	SSC value + 1 cycle (6.25 μs)	4 cycles (1.0 μs)
Setup time	$\frac{SSC\ value + 1}{2}$ cycle < 4.0 μs (3.125 μs)	2 cycles (1.0 μs)
Hold time	$\frac{SSC\ value + 1}{2}$ cycle < 4.0 μs (3.125 μs)	2 cycles (0.5 μs)
BB flag set/reset time	$\frac{SSC\ value - 1}{2}$ + 2 cycles (3.375 μs)	3.5 cycles (0.875 μs)

Note: Unit : Cycle number of system clock φ
 SSC value is the decimal notation value of the START/STOP condition set bits SSC4 to SSC0. Do not set "0" or an odd number to SSC value. The value in parentheses is an example when the I²C START/STOP condition control register is set to "1816" at φ = 4 MHz.

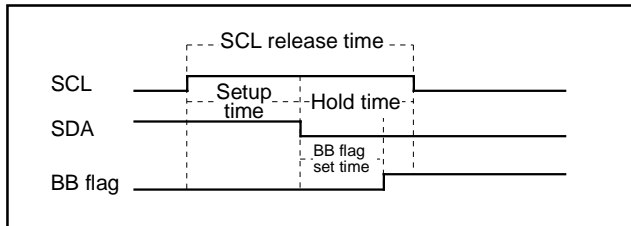

Fig. 70 START/STOP condition detecting timing diagram

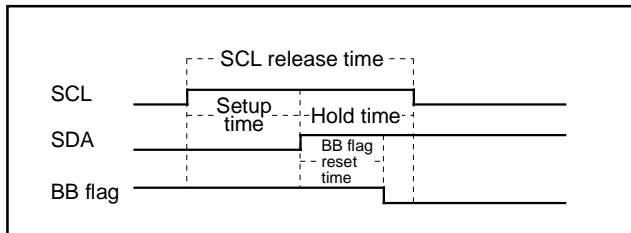

Fig. 71 STOP condition detecting timing diagram

[I²C START/STOP Condition Control Register (S2D)] 001616

The I²C START/STOP condition control register (S2D: address 001616) controls START/STOP condition detection.

•Bits 0 to 4: START/STOP condition set bit (SSC4–SSC0)

SCL release time, setup time, and hold time change the detection condition by value of the main clock divide ratio selection bit and the oscillation frequency f(XIN) because these time are measured by the internal system clock. Accordingly, set the proper value to the START/STOP condition set bits (SSC4 to SSC0) in considered of the system clock frequency. Refer to Table 12.

Do not set "000002" or an odd number to the START/STOP condition set bit (SSC4 to SSC0).

Refer to Table 13, the recommended set value to START/STOP condition set bits (SSC4–SSC0) for each oscillation frequency.

•Bit 5: SCL/SDA interrupt pin polarity selection bit (SIP)

An interrupt can occur when detecting the falling or rising edge of the SCL or SDA pin. This bit selects the polarity of the SCL or SDA pin interrupt pin.

•Bit 6: SCL/SDA interrupt pin selection bit (SIS)

This bit selects the pin of which interrupt becomes valid between the SCL pin and the SDA pin.

Note: When changing the setting of the SCL/SDA interrupt pin polarity selection bit, the SCL/SDA interrupt pin selection bit, or the I²C-BUS interface enable bit ES0, the SCL/SDA interrupt request bit may be set. When selecting the SCL/SDA interrupt source, disable the interrupt before the SCL/SDA interrupt pin polarity selection bit, the SCL/SDA interrupt pin selection bit, or the I²C-BUS interface enable bit ES0 is set. Reset the request bit to "0" after setting these bits, and enable the interrupt.

•Bit 7: Data receive mode at Stop/Low-speed mode bit (STR)

Setting this bit to "1" enables to receive an address data even in the stop mode or the low-speed mode by making the built-in CR oscillator oscillate.

The I²C interrupt request occurs and the PIN bit changes to "0" from "1" when the address data agrees with the contents of I²C slave address register or a general call is received. The XIN is not oscillating when receiving an address data. Before performing communication after receiving an address data, start the XIN oscillation using this interrupt and switch the main clock to high-speed or middle-speed mode.

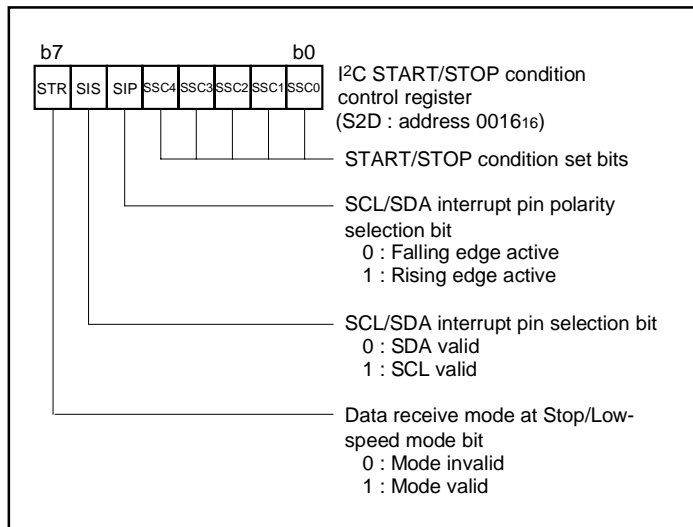

Fig. 72 Structure of I²C START/STOP condition control register

Table 13 Recommended set value to START/STOP condition set bits (SSC4–SSC0) for each oscillation frequency

Oscillation frequency f(XIN) (MHz)	Main clock divide ratio	System clock ϕ (MHz)	START/STOP condition control register	SCL release time (μ s)	Setup time (μ s)	Hold time (μ s)
8	2	4	XXX11010	6.75 μ s (27 cycles)	3.5 μ s (14 cycles)	3.25 μ s (13 cycles)
			XXX11000	6.25 μ s (25 cycles)	3.25 μ s (13 cycles)	3.0 μ s (12 cycles)
8	8	1	XXX00100	5.0 μ s (5 cycles)	3.0 μ s (3 cycles)	2.0 μ s (2 cycles)
4	2	2	XXX01100	6.5 μ s (13 cycles)	3.5 μ s (7 cycles)	3.0 μ s (6 cycles)
			XXX01010	5.5 μ s (11 cycles)	3.0 μ s (6 cycles)	2.5 μ s (5 cycles)
2	2	1	XXX00100	5.0 μ s (5 cycles)	3.0 μ s (3 cycles)	2.0 μ s (2 cycles)

Note: Do not set an odd number to the START/STOP condition set bit (SSC4 to SSC0) and "000002".

**[I²C Special Mode Status Register (S3)]
001216**

The I²C special mode status register (S3: address 001216) consists of the flags indicating I²C operating state in the I²C special mode, which is set by the I²C special mode control register (S3D: address 001716).

The stop condition flag is valid in all operating modes.

•Bit 0: Slave address 0 comparison flag (AAS0)

Bit 1: Slave address 1 comparison flag (AAS1)

Bit 2: Slave address 2 comparison flag (AAS2)

These flags indicate a comparison result of address data. These flags are valid only when the slave address control bit (MSLAD) is "1".

In the 7-bit addressing format of the slave reception mode, the respective slave address *i* (*i* = 0, 1, 2) comparison flags corresponding to the I²C slave address registers 0 to 2 are set to "1" when an address data immediately after an occurrence of a START condition agrees with the high-order 7-bit slave address stored in the I²C slave address registers 0 to 2 (addresses 0FF716 to 0FF916).

In the 10-bit addressing format of the slave mode, the respective slave address *i* (*i* = 0, 1, 2) comparison flags corresponding to the I²C slave address registers are set to "1" when an address data is compared with the 8 bits consisting of the slave address stored in the I²C slave address registers 0 to 2 and the RWB bit, and the first byte agrees.

These flags are initialized to "0" at reset, when the slave address control bit (MSLAD) is "0", or when writing data to the I²C data shift register (S0: address 001116).

•Bit 4: Time out flag (TIOU)

This flag is valid only when the data receive mode at Stop/Low-speed mode bit (STR) and the I²C time out control bit (TOEN) are "1". This flag is set to "1" when the I²C bus communication does not end within about 26 ms at 8 MHz operating from an occurrence of a START condition, owing to any reason. The SCL/SDA interrupt request simultaneously occurs.

This flag is initialized to "0" in the following conditions:

- At reset
- When the I²C-BUS interface enable bit (ES0) is "0"
- When the I²C time out control bit (TOEN) is "0"
- When writing "1" to the time out flag clear bit (TOFCL).

•Bit 5: SCL pin low hold 2 flag (PIN2)

When the ACK interrupt control bit (ACKICON) and the ACK clock bit (ACK) are "1", this flag is set to "0" in synchronization with the falling of the data's last SCL clock, just before the ACK clock. The SCL pin is simultaneously held low, and the I²C interrupt request occurs.

This flag is initialized to "1" at reset, when the ACK interrupt control bit (ACKICON) is "0", or when writing "1" to the SCL pin low hold 2 flag set bit (PIN2IN).

The SCL pin is held low when either the SCL pin low hold bit (PIN) or the SCL pin low hold 2 flag (PIN2) becomes "0". The low hold state of the SCL pin is released when both the SCL pin low hold bit (PIN) and the SCL pin low hold 2 flag (PIN2) are "1".

•Bit 7: Stop condition flag (SPCF)

This flag is set to "1" when a STOP condition occurs.

This flag is initialized to "0" at reset, when the I²C-BUS interface enable bit (ES0) is "0", or when writing "1" to the STOP condition flag clear bit (SPFCL).

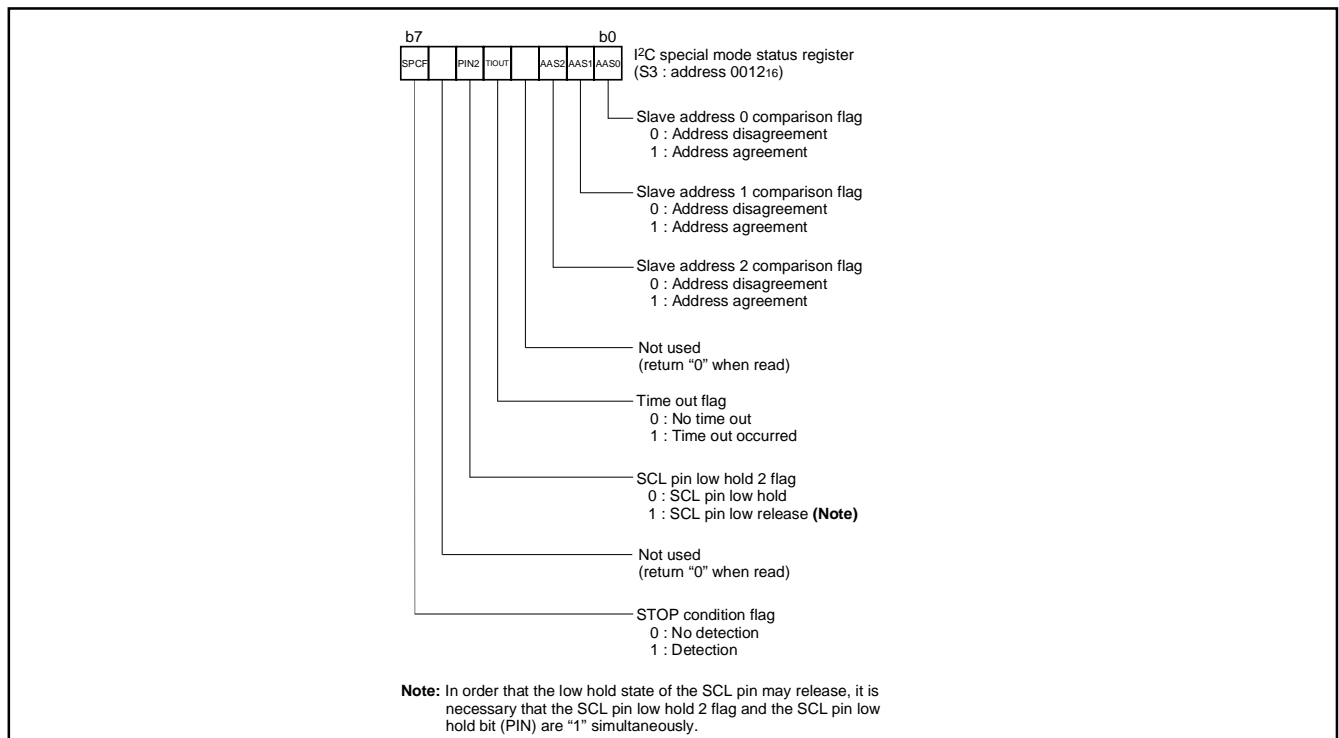

Fig. 73 Structure of I²C special mode status register

**[I²C Special Mode Control Register (S3D)]
001716**

The I²C special mode control register (S3D: address 001716) controls special functions such as the time out function, occurrence timing of reception interrupt request and extending slave address comparison to 3 bytes.

•Bit 0: I²C time out control bit (TOEN)

In the condition that this bit and the data receive mode at Stop/Low-speed mode bit (STR) are "1", the time out flag (TIOUT) is set to "1" when the I²C bus communication does not end within about 26 ms at 8 MHz operating from an occurrence of a start condition, owing to any reason. The SCL/SDA interrupt request simultaneously occurs.

The time out function is disabled when the I²C time out control bit is "0".

•Bit 1: ACK interrupt control bit (ACKICON)

This bit controls the timing of I²C interrupt request occurrence at completion of data receiving due to master reception or slave reception.

When this bit is "0", the SCL pin low hold bit (PIN) is set to "0" in synchronization with the falling of the last SCL clock, including the ACK clock. The SCL pin is simultaneously held low, and the I²C interrupt request occurs.

When this bit is "1" and the ACK clock bit (ACK) is "1", the SCL pin low hold 2 flag (PIN2) is set to "0" in synchronization with the falling of the data's last SCL clock, just before the ACK clock. The SCL pin is simultaneously held low, and the I²C interrupt request occurs again. The ACK bit can be changed after the contents of data are confirmed by using this function.

•Bit 2: I²C slave address control bit (MSLAD)

This bit controls a slave address. When this bit is "0", only the I²C slave address register 0 (address 0FF716) becomes valid as a slave address and a read/write bit.

When this bit is "1", all of the I²C slave address registers 0 to 2 (addresses 0FF716 to 0FF916) become valid as a slave address and a read/write bit. In this case, when an address data agrees with any one of the I²C slave address registers 0 to 2, the slave address comparison flag (AAS) is set to "1" and the I²C slave address comparison flag corresponding to the agreed I²C slave address registers 0 to 2 is also set to "1".

•Bit 4: Time out flag clear bit (TOFCL)

Writing "1" to this bit initializes the time out flag to "0".

When writing "0", nothing is generated.

•Bit 5: SCL pin low hold 2 flag set bit (PIN2IN)

Writing "1" to this bit initializes the SCL pin low hold 2 flag (PIN2) to "1".

When writing "0", nothing is generated.

•Bit 6: SCL pin low hold set bit (PIN2HD)

When the SCL pin low hold bit (PIN) becomes "0", the SCL pin is held low. However, the SCL pin low hold bit (PIN) cannot be set to "0" by software. The SCL pin low hold set bit (PIN2HD) is used to hold the SCL pin in the low state by software. When writing "1" to this bit, the SCL pin low hold 2 flag (PIN2) becomes "0", and the SCL pin is held low. When writing "0", nothing occurs.

•Bit 7: STOP condition flag clear bit (SPFCL)

Writing "1" to this bit initializes the STOP condition flag (SPCF) to "0".

When writing "0", nothing is generated.

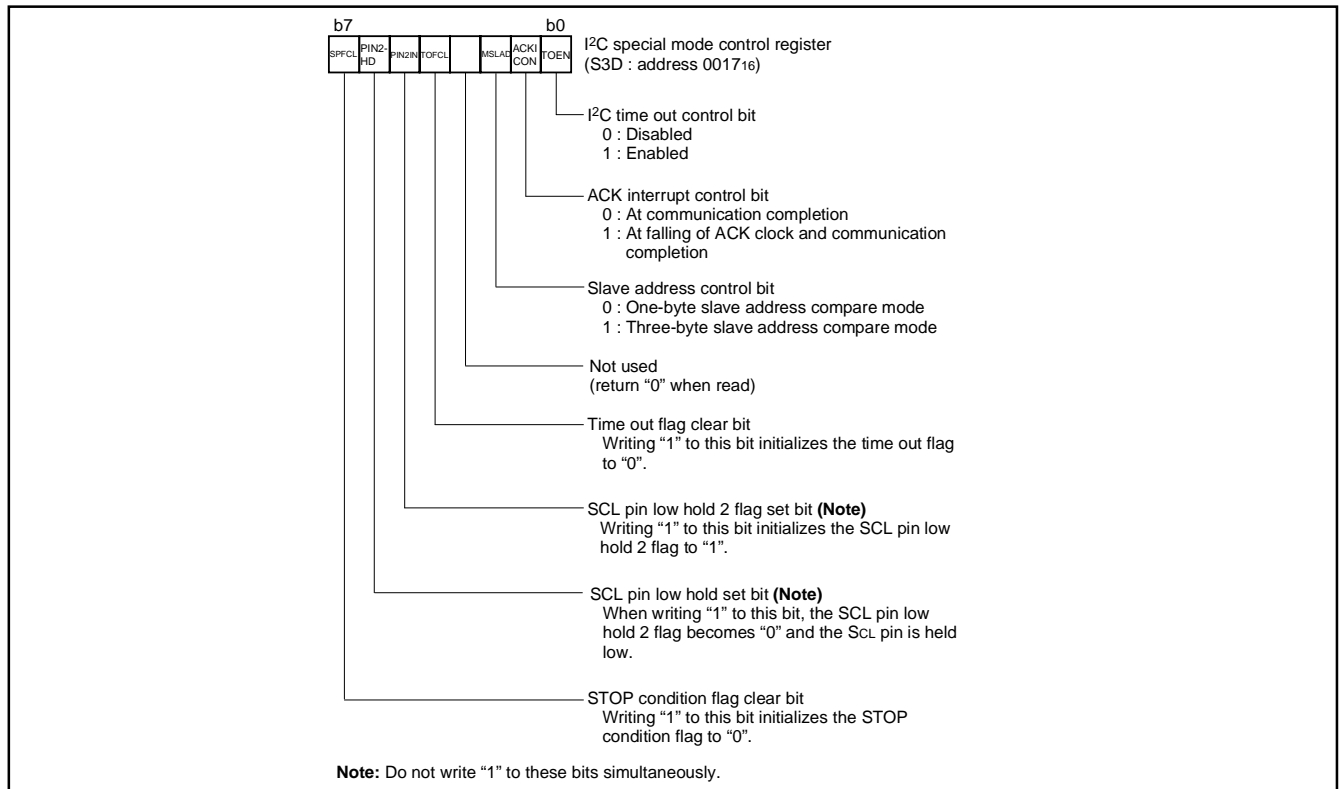

Fig. 74 Structure of I²C special mode control register

Address Data Communication

There are two address data communication formats, namely, 7-bit addressing format and 10-bit addressing format. The respective address communication formats are described below.

① 7-bit addressing format

To adapt the 7-bit addressing format, set the 10BIT SAD bit of the I²C control register (S1D: address 0014₁₆) to "0". The first 7-bit address data transmitted from the master is compared with the high-order 7-bit slave address stored in the I²C slave address register. At the time of this comparison, address comparison of the RWB bit of the I²C slave address register is not performed. For the data transmission format when the 7-bit addressing format is selected, refer to Figure 75, (1) and (2).

② 10-bit addressing format

To adapt the 10-bit addressing format, set the 10BIT SAD bit of the I²C control register (S1D: address 0014₁₆) to "1." An address comparison is performed between the first-byte address data transmitted from the master and the 8-bit slave address stored in the I²C slave address register. At the time of this com-

parison, an address comparison between the RWB bit of the I²C slave address register and the R/W bit which is the last bit of the address data transmitted from the master is made. In the 10-bit addressing mode, the RWB bit which is the last bit of the address data not only specifies the direction of communication for control data, but also is processed as an address data bit.

When the first-byte address data agree with the slave address, the AAS bit of the I²C status register (S1: address 0013₁₆) is set to "1." After the second-byte address data is stored into the I²C data shift register (S0: address 0011₁₆), perform an address comparison between the second-byte data and the slave address by software. When the address data of the 2 bytes agree with the slave address, set the RWB bit of the I²C slave address register to "1" by software. This processing can make the 7-bit slave address and R/W data agree, which are received after a RESTART condition is detected, with the value of the I²C slave address register. For the data transmission format when the 10-bit addressing format is selected, refer to Figure 75, (3) and (4).

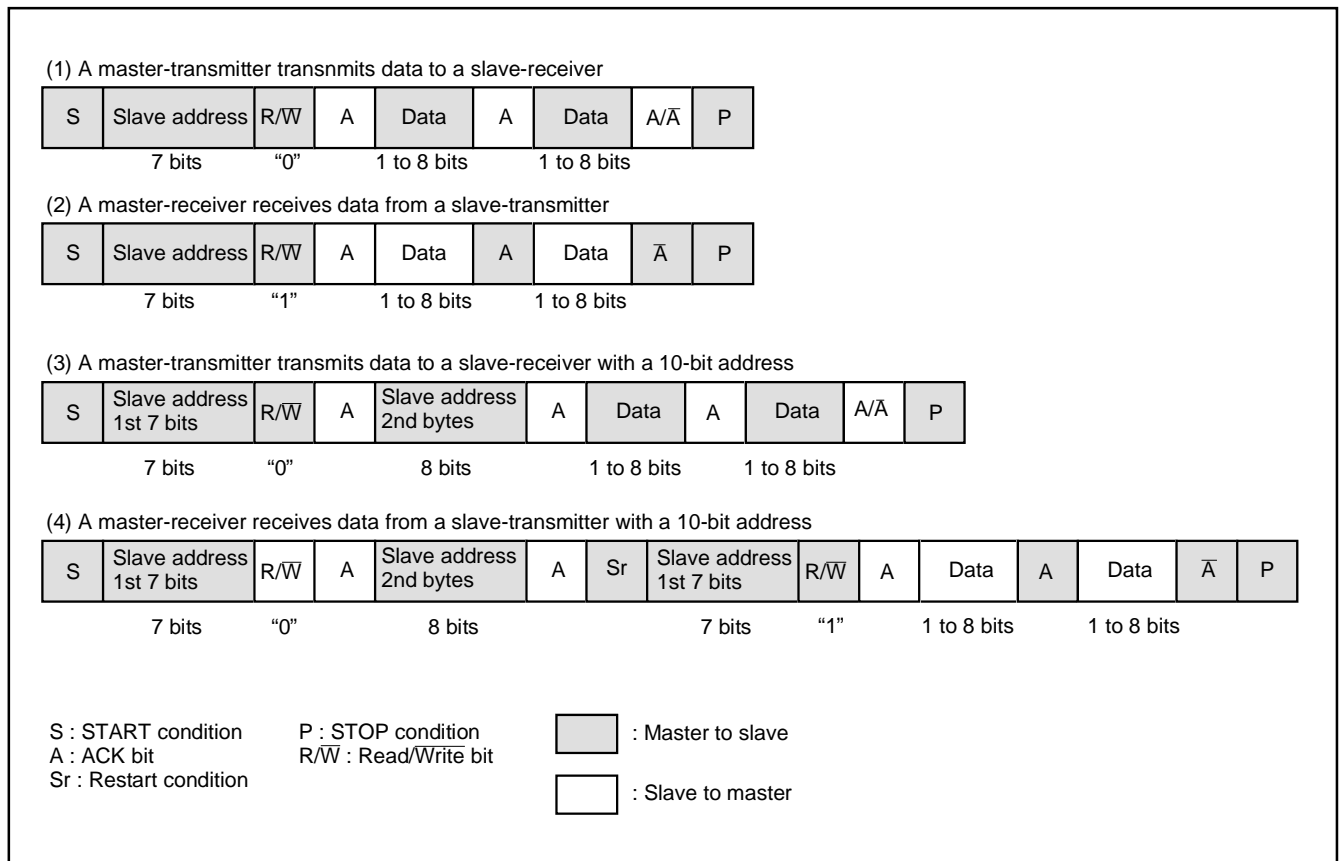

Fig. 75 Address data communication format

Example of Master Transmission

An example of master transmission in the standard clock mode, at the SCL frequency of 100 kHz and in the ACK return mode is shown below.

- ① Set a slave address in the high-order 7 bits of the I²C slave address register and "0" into the RWB bit.
- ② Set the ACK return mode and SCL = 100 kHz by setting "85₁₆" in the I²C clock control register (S2: address 0015₁₆).
- ③ Set "00₁₆" in the I²C status register (S1: address 0013₁₆) so that transmission/reception mode can become initializing condition.
- ④ Set a communication enable status by setting "08₁₆" in the I²C control register (S1D: address 0014₁₆).
- ⑤ Confirm the bus free condition by the BB flag of the I²C status register (S1: address 0013₁₆).
- ⑥ Set the address data of the destination of transmission in the high-order 7 bits of the I²C data shift register (S0: address 0011₁₆) and set "0" in the least significant bit.
- ⑦ Set "F0₁₆" in the I²C status register (S1: address 0013₁₆) to generate a START condition. At this time, an SCL for 1 byte and an ACK clock automatically occur.
- ⑧ Set transmit data in the I²C data shift register (S0: address 0011₁₆). At this time, an SCL and an ACK clock automatically occur.
- ⑨ When transmitting control data of more than 1 byte, repeat step ⑧.
- ⑩ Set "D0₁₆" in the I²C status register (S1: address 0013₁₆) to generate a STOP condition if ACK is not returned from slave reception side or transmission ends.

Example of Slave Reception

An example of slave reception in the high-speed clock mode, at the SCL frequency of 400 kHz, in the ACK non-return mode and using the addressing format is shown below.

- ① Set a slave address in the high-order 7 bits of the I²C slave address register and "0" in the RWB bit.
- ② Set the no ACK clock mode and SCL = 400 kHz by setting "25₁₆" in the I²C clock control register (S2: address 0015₁₆).
- ③ Set "00₁₆" in the I²C status register (S1: address 0013₁₆) so that transmission/reception mode can become initializing condition.
- ④ Set a communication enable status by setting "08₁₆" in the I²C control register (S1D: address 0014₁₆).
- ⑤ When a START condition is received, an address comparison is performed.
- ⑥ •When all transmitted addresses are "0" (general call):
 ADO of the I²C status register (S1: address 0013₁₆) is set to "1" and an interrupt request signal occurs.
 • When the transmitted addresses agree with the address set in ①:
 AAS of the I²C status register (S1: address 0013₁₆) is set to "1" and an interrupt request signal occurs.
 • In the cases other than the above ADO and ASS of the I²C status register (S1: address 0013₁₆) are set to "0" and no interrupt request signal occurs.
- ⑦ Set dummy data in the I²C data shift register (S0: address 0011₁₆).
- ⑧ When receiving control data of more than 1 byte, repeat step ⑦.
- ⑨ When a STOP condition is detected, the communication ends.

■Precautions when using multi-master I²C-BUS interface

(1) Read-modify-write instruction

The precautions when the read-modify-write instruction such as SEB, CLB etc. is executed for each register of the multi-master I²C-BUS interface are described below.

- I²C data shift register (S0: address 0011₁₆)
When executing the read-modify-write instruction for this register during transfer, data may become a value not intended.
- I²C slave address registers 0 to 2 (S0D0 to S0D2: addresses 0FF7₁₆ to 0FF9₁₆)
When the read-modify-write instruction is executed for this register at detecting the STOP condition, data may become a value not intended. It is because H/W changes the read/write bit (RWB) at the above timing.
- I²C status register (S1: address 0013₁₆)
Do not execute the read-modify-write instruction for this register because all bits of this register are changed by H/W.
- I²C control register (S1D: address 0014₁₆)
When the read-modify-write instruction is executed for this register at detecting the START condition or at completing the byte transfer, data may become a value not intended. Because H/W changes the bit counter (BC0-BC2) at the above timing.
- I²C clock control register (S2: address 0015₁₆)
The read-modify-write instruction can be executed for this register.
- I²C START/STOP condition control register (S2D: address 0016₁₆)
The read-modify-write instruction can be executed for this register.

(2) START condition generating procedure using multi-master

1. Procedure example (The necessary conditions of the generating procedure are described as the following 2 to 5.)

```

:
LDA —          (Taking out of slave address value)
SEI             (Interrupt disabled)
BBS 5, S1, BUSBUSY (BB flag confirming and branch process)
BUSFREE:
STA S0         (Writing of slave address value)
LDM #F0, S1   (Trigger of START condition generating)
CLI           (Interrupt enabled)
:
BUSBUSY:
CLI           (Interrupt enabled)
:

```

2. Use "Branch on Bit Set" of "BBS 5, \$0014, -" for the BB flag confirming and branch process.
3. Use "STA \$12, STX \$12" or "STY \$12" of the zero page addressing instruction for writing the slave address value to the I²C data shift register.
4. Execute the branch instruction of above 2 and the store instruction of above 3 continuously shown the above procedure example.

5. Disable interrupts during the following three process steps:

- BB flag confirming
- Writing of slave address value
- Trigger of START condition generating

When the condition of the BB flag is bus busy, enable interrupts immediately.

(3) RESTART condition generating procedure

1. Procedure example (The necessary conditions of the generating procedure are described as the following 2 to 4.)

Execute the following procedure when the PIN bit is "0."

```

:
LDM #S00, S1   (Select slave receive mode)
LDA —         (Taking out of slave address value)
SEI           (Interrupt disabled)
STA S0        (Writing of slave address value)
LDM #F0, S1   (Trigger of RESTART condition generating)
CLI          (Interrupt enabled)
:

```

2. Select the slave receive mode when the PIN bit is "0." Do not write "1" to the PIN bit. Neither "0" nor "1" is specified for the writing to the BB bit.

The TRX bit becomes "0" and the SDA pin is released.

3. The SCL pin is released by writing the slave address value to the I²C data shift register.

4. Disable interrupts during the following two process steps:

- Writing of slave address value
- Trigger of RESTART condition generating

(4) Writing to I²C status register

Do not execute an instruction to set the PIN bit to "1" from "0" and an instruction to set the MST and TRX bits to "0" from "1" simultaneously. It is because it may enter the state that the SCL pin is released and the SDA pin is released after about one machine cycle. Do not execute an instruction to set the MST and TRX bits to "0" from "1" simultaneously when the PIN bit is "1." It is because it may become the same as above.

(5) Process of after STOP condition generating

Do not write data in the I²C data shift register S0 and the I²C status register S1 until the bus busy flag BB becomes "0" after generating the STOP condition in the master mode. It is because the STOP condition waveform might not be normally generated. Reading to the above registers does not have the problem.

RESET CIRCUIT

To reset the microcomputer, $\overline{\text{RESET}}$ pin should be held at an "L" level for 2 μs or more. Then the $\overline{\text{RESET}}$ pin is returned to an "H" level (the power source voltage should be between 2.7 V and 5.5 V, and the oscillation should be stable), reset is released. After the reset is completed, the program starts from the address contained in address FFFD₁₆ (high-order byte) and address FFFC₁₆ (low-order byte). Make sure that the reset input voltage is less than 0.54 V for Vcc of 2.7 V.

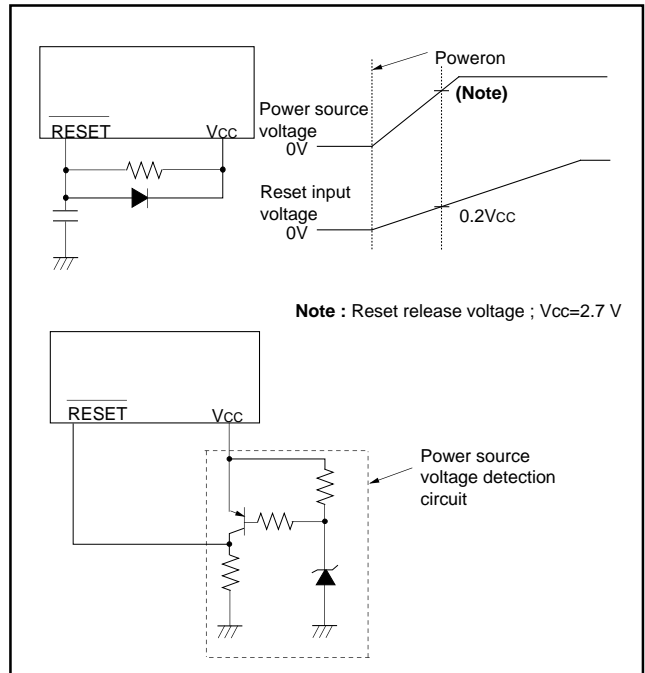

Fig. 76 Reset circuit example

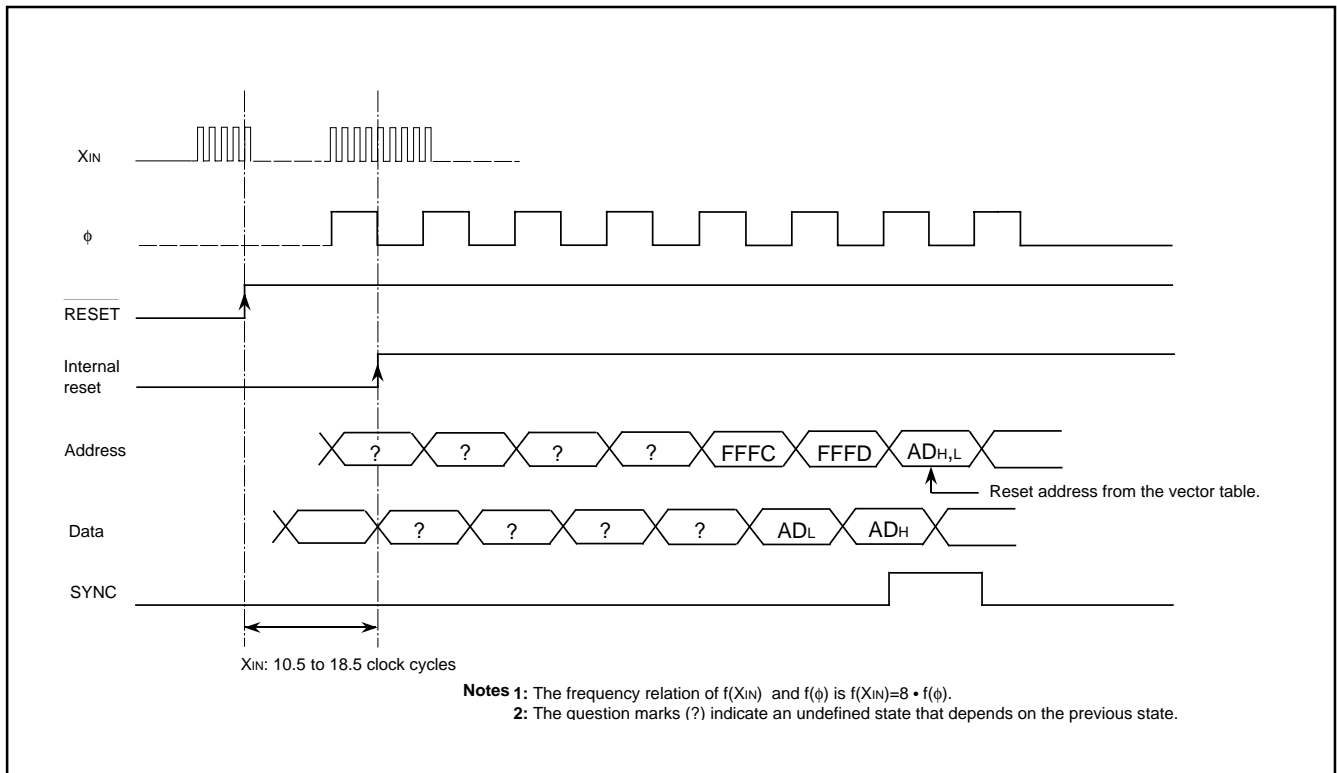

Fig. 77 Reset sequence

	Address	Register contents		Address	Register contents
(1) Port P0 (P0)	0000 ₁₆	00 ₁₆	(34) Timer Z (low-order) (TZL)	0028 ₁₆	FF ₁₆
(2) Port P0 direction register (P0D)	0001 ₁₆	00 ₁₆	(35) Timer Z (high-order) (TZH)	0029 ₁₆	FF ₁₆
(3) Port P1 (P1)	0002 ₁₆	00 ₁₆	(36) Timer Z mode register (TZM)	002A ₁₆	00 ₁₆
(4) Port P1 direction register (P1D)	0003 ₁₆	00 ₁₆	(37) PWM control register (PWMCN)	002B ₁₆	00 ₁₆
(5) Port P2 (P2)	0004 ₁₆	00 ₁₆	(38) PWM prescaler (PREPWM)	002C ₁₆	X X X X X X X X
(6) Port P2 direction register (P2D)	0005 ₁₆	00 ₁₆	(39) PWM register (PWM)	002D ₁₆	X X X X X X X X
(7) Port P3 (P3)	0006 ₁₆	00 ₁₆	(40) Baud rate generator 3 (BRG3)	002F ₁₆	X X X X X X X X
(8) Port P3 direction register (P3D)	0007 ₁₆	00 ₁₆	(41) Transmit/Receive buffer register 3 (TB3/RB3)	0030 ₁₆	X X X X X X X X
(9) Port P4 (P4)	0008 ₁₆	00 ₁₆	(42) Serial I/O3 status register (SIO3STS)	0031 ₁₆	1 0 0 0 0 0 0 0
(10) Port P4 direction register (P4D)	0009 ₁₆	00 ₁₆	(43) Serial I/O3 control register (SIO3CON)	0032 ₁₆	00 ₁₆
(11) Port P5 (P5)	000A ₁₆	00 ₁₆	(44) UART3 control register (SIO3CON)	0033 ₁₆	1 1 1 0 0 0 0 0
(12) Port P5 direction register (P5D)	000B ₁₆	00 ₁₆	(45) AD/DA control register (ADCON)	0034 ₁₆	0 0 0 0 1 0 0 0
(13) Port P6 (P6)	000C ₁₆	00 ₁₆	(46) A-D conversion register 1 (AD1)	0035 ₁₆	X X X X X X X X
(14) Port P6 direction register (P6D)	000D ₁₆	00 ₁₆	(47) D-A1 conversion register (DA1)	0036 ₁₆	00 ₁₆
(15) Timer 12, X count source selection register (T12XCSS)	000E ₁₆	0 0 1 1 0 0 1 1	(48) D-A2 conversion register (DA2)	0037 ₁₆	00 ₁₆
(16) Timer Y, Z count source selection register (TYZCSS)	000F ₁₆	0 0 1 1 0 0 1 1	(49) A-D conversion register 2 (AD2)	0038 ₁₆	0 0 0 0 0 0 X X
(17) MISRG	0010 ₁₆	00 ₁₆	(50) Interrupt source selection register (INTSEL)	0039 ₁₆	00 ₁₆
(18) Transmit/Receive buffer register 1 (TB1/RB1)	0018 ₁₆	X X X X X X X X	(51) Interrupt edge selection register (INTEGE)	003A ₁₆	00 ₁₆
(19) Serial I/O1 status register (SIO1STS)	0019 ₁₆	1 0 0 0 0 0 0 0	(52) CPU mode register (CPUM)	003B ₁₆	0 1 0 0 1 0 0 0
(20) Serial I/O1 control register (SIO1CON)	001A ₁₆	00 ₁₆	(53) Interrupt request register 1 (IREQ1)	003C ₁₆	00 ₁₆
(21) UART1 control register (UART1CON)	001B ₁₆	1 1 1 0 0 0 0 0	(54) Interrupt request register 2 (IREQ2)	003D ₁₆	00 ₁₆
(22) Baud rate generator 1 (BRG1)	001C ₁₆	X X X X X X X X	(55) Interrupt control register 1 (ICON1)	003E ₁₆	00 ₁₆
(23) Serial I/O2 control register (SIO2CON)	001D ₁₆	00 ₁₆	(56) Interrupt control register 2 (ICON2)	003F ₁₆	00 ₁₆
(24) Watchdog timer control register (WDTCON)	001E ₁₆	0 0 1 1 1 1 1 1	(57) Port P0 pull-up control register (PULL0)	0FF0 ₁₆	00 ₁₆
(25) Serial I/O2 register (SIO2)	001F ₁₆	X X X X X X X X	(58) Port P1 pull-up control register (PULL1)	0FF1 ₁₆	00 ₁₆
(26) Prescaler 12 (PRE12)	0020 ₁₆	FF ₁₆	(59) Port P2 pull-up control register (PULL2)	0FF2 ₁₆	00 ₁₆
(27) Timer 1 (T1)	0021 ₁₆	01 ₁₆	(60) Port P3 pull-up control register (PULL3)	0FF3 ₁₆	00 ₁₆
(28) Timer 2 (T2)	0022 ₁₆	FF ₁₆	(61) Port P4 pull-up control register (PULL4)	0FF4 ₁₆	00 ₁₆
(29) Timer XY mode register (TM)	0023 ₁₆	00 ₁₆	(62) Port P5 pull-up control register (PULL5)	0FF5 ₁₆	00 ₁₆
(30) Prescaler X (PREX)	0024 ₁₆	FF ₁₆	(63) Port P6 pull-up control register (PULL6)	0FF6 ₁₆	00 ₁₆
(31) Timer X (TX)	0025 ₁₆	FF ₁₆	(64) Flash memory control register (FCON)	0FFE ₁₆	00 ₁₆
(32) Prescaler Y (PREY)	0026 ₁₆	FF ₁₆	(65) Flash command register (FCMD)	0FFF ₁₆	00 ₁₆
(33) Timer Y (TY)	0027 ₁₆	FF ₁₆	(66) Processor status register (PS)	X X X X X X 1 X X	
			(67) Program counter (PC _H)	FFF ₁₆ contents	
			(PC _L)	FFF ₁₆ contents	

Note : X : Not fixed
 Since the initial values for other than above mentioned registers and RAM contents are indefinite at reset, they must be set.

Fig. 78 Internal status at reset (3803 group)

	Address	Register contents		Address	Register contents
(1) Port P0 (P0)	0000 ₁₆	00 ₁₆	(41) Timer Z (low-order) (TZL)	0028 ₁₆	FF ₁₆
(2) Port P0 direction register (P0D)	0001 ₁₆	00 ₁₆	(42) Timer Z (high-order) (TZH)	0029 ₁₆	FF ₁₆
(3) Port P1 (P1)	0002 ₁₆	00 ₁₆	(43) Timer Z mode register (TZM)	002A ₁₆	00 ₁₆
(4) Port P1 direction register (P1D)	0003 ₁₆	00 ₁₆	(44) PWM control register (PWMCON)	002B ₁₆	00 ₁₆
(5) Port P2 (P2)	0004 ₁₆	00 ₁₆	(45) PWM prescaler (PREPWM)	002C ₁₆	X X X X X X X X
(6) Port P2 direction register (P2D)	0005 ₁₆	00 ₁₆	(46) PWM register (PWM)	002D ₁₆	X X X X X X X X
(7) Port P3 (P3)	0006 ₁₆	00 ₁₆	(47) Baud rate generator 3 (BRG3)	002F ₁₆	X X X X X X X X
(8) Port P3 direction register (P3D)	0007 ₁₆	00 ₁₆	(48) Transmit/Receive buffer register 3 (TB3/RB3)	0030 ₁₆	X X X X X X X X
(9) Port P4 (P4)	0008 ₁₆	00 ₁₆	(49) Serial I/O3 status register (SIO3STS)	0031 ₁₆	1 0 0 0 0 0 0 0
(10) Port P4 direction register (P4D)	0009 ₁₆	00 ₁₆	(50) Serial I/O3 control register (SIO3CON)	0032 ₁₆	00 ₁₆
(11) Port P5 (P5)	000A ₁₆	00 ₁₆	(51) UART3 control register (SIO3CON)	0033 ₁₆	1 1 1 0 0 0 0 0
(12) Port P5 direction register (P5D)	000B ₁₆	00 ₁₆	(52) AD/DA control register (ADCON)	0034 ₁₆	0 0 0 0 1 0 0 0
(13) Port P6 (P6)	000C ₁₆	00 ₁₆	(53) A-D conversion register 1 (AD1)	0035 ₁₆	X X X X X X X X
(14) Port P6 direction register (P6D)	000D ₁₆	00 ₁₆	(54) D-A1 conversion register (DA1)	0036 ₁₆	00 ₁₆
(15) Timer 12, X count source selection register (T12XCSS)	000E ₁₆	0 0 1 1 0 0 1 1	(55) D → A.2 conversion register (DA2)	0037 ₁₆	00 ₁₆
(16) Timer Y, Z count source selection register (TYZCSS)	000F ₁₆	0 0 1 1 0 0 1 1	(56) A → D conversion register 2 (AD2)	0038 ₁₆	0 0 0 0 0 0 X X
(17) MISRG	0010 ₁₆	00 ₁₆	(57) Interrupt source selection register (INTSEL)	0039 ₁₆	00 ₁₆
(18) I ² C data shift register (S0)	0011 ₁₆	X X X X X X X X	(58) Interrupt edge selection register (INTEDGE)	003A ₁₆	00 ₁₆
(19) I ² C special mode status register (S3)	0012 ₁₆	0 0 1 0 0 0 0 0	(59) CPU mode register (CPUM)	003B ₁₆	0 1 0 0 1 0 0 0
(20) I ² C status register (S1)	0013 ₁₆	0 0 0 1 0 0 0 X	(60) Interrupt request register 1 (IREQ1)	003C ₁₆	00 ₁₆
(21) I ² C control register (S1D)	0014 ₁₆	00 ₁₆	(61) Interrupt request register 2 (IREQ2)	003D ₁₆	00 ₁₆
(22) I ² C clock control register (S2)	0015 ₁₆	00 ₁₆	(62) Interrupt control register 1 (ICON1)	003E ₁₆	00 ₁₆
(23) I ² C START/STOP condition control register (S2D)	0016 ₁₆	0 0 0 1 1 0 1 0	(63) Interrupt control register 2 (ICON2)	003F ₁₆	00 ₁₆
(24) I ² C special mode control register (S3D)	0017 ₁₆	00 ₁₆	(64) Port P0 pull-up control register (PULL0)	0FF0 ₁₆	00 ₁₆
(25) Transmit/Receive buffer register 1 (TB1/RB1)	0018 ₁₆	X X X X X X X X	(65) Port P1 pull-up control register (PULL1)	0FF1 ₁₆	00 ₁₆
(26) Serial I/O1 status register (SIO1STS)	0019 ₁₆	1 0 0 0 0 0 0 0	(66) Port P2 pull-up control register (PULL2)	0FF2 ₁₆	00 ₁₆
(27) Serial I/O1 control register (SIO1CON)	001A ₁₆	00 ₁₆	(67) Port P3 pull-up control register (PULL3)	0FF3 ₁₆	00 ₁₆
(28) UART1 control register (UART1CON)	001B ₁₆	1 1 1 0 0 0 0 0	(68) Port P4 pull-up control register (PULL4)	0FF4 ₁₆	00 ₁₆
(29) Baud rate generator 1 (BRG1)	001C ₁₆	X X X X X X X X	(69) Port P5 pull-up control register (PULL5)	0FF5 ₁₆	00 ₁₆
(30) Serial I/O2 control register (SIO2CON)	001D ₁₆	00 ₁₆	(70) Port P6 pull-up control register (PULL6)	0FF6 ₁₆	00 ₁₆
(31) Watchdog timer control register (WDTCON)	001E ₁₆	0 0 1 1 1 1 1 1	(71) I ² C slave address register 0 (S0D0)	0FF7 ₁₆	00 ₁₆
(32) Serial I/O2 register (SIO2)	001F ₁₆	X X X X X X X X	(72) I ² C slave address register 1 (S0D1)	0FF8 ₁₆	00 ₁₆
(33) Prescaler 12 (PRE12)	0020 ₁₆	FF ₁₆	(73) I ² C slave address register 2 (S0D3)	0FF9 ₁₆	00 ₁₆
(34) Timer 1 (T1)	0021 ₁₆	01 ₁₆	(74) Flash memory control register (FCON)	0FFE ₁₆	00 ₁₆
(35) Timer 2 (T2)	0022 ₁₆	FF ₁₆	(75) Flash command register (FCMD)	0FFF ₁₆	00 ₁₆
(36) Timer XY mode register (TM)	0023 ₁₆	00 ₁₆	(76) Processor status register (PS)	X X X X X 1 X X	
(37) Prescaler X (PREX)	0024 ₁₆	FF ₁₆	(77) Program counter (PC _H)	FFFF ₁₆ contents	
(38) Timer X (TX)	0025 ₁₆	FF ₁₆	(PC _L)	FFFC ₁₆ contents	
(39) Prescaler Y (PREY)	0026 ₁₆	FF ₁₆			
(40) Timer Y (TY)	0027 ₁₆	FF ₁₆			

Note : X : Not fixed
 Since the initial values for other than above mentioned registers and RAM contents are indefinite at reset, they must be set.

Fig. 79 Internal status at reset (3804 group)

CLOCK GENERATING CIRCUIT

The M38039FFSP/FP has two built-in oscillation circuits. An oscillation circuit can be formed by connecting a resonator between XIN and XOUT (XCIN and XCOU). Use the circuit constants in accordance with the resonator manufacturer's recommended values. No external resistor is needed between XIN and XOUT since a feed-back resistor exists on-chip. However, an external feed-back resistor is needed between XCIN and XCOU.

Immediately after power on, only the XIN oscillation circuit starts oscillating, and XCIN and XCOU pins function as I/O ports.

Frequency Control

(1) Middle-speed mode

The internal clock ϕ is the frequency of XIN divided by 8. After reset, this mode is selected.

(2) High-speed mode

The internal clock ϕ is half the frequency of XIN.

(3) Low-speed mode

The internal clock ϕ is half the frequency of XCIN.

■Note

If you switch the mode between middle/high-speed and low-speed, stabilize both XIN and XCIN oscillations. The sufficient time is required for the sub clock to stabilize, especially immediately after power on and at returning from stop mode. When switching the mode between middle/high-speed and low-speed, set the frequency on condition that $f(XIN) > 3f(XCIN)$.

(4) Low power dissipation mode

The low power consumption operation can be realized by stopping the main clock XIN in low-speed mode. To stop the main clock, set bit 5 of the CPU mode register to "1." When the main clock XIN is restarted (by setting the main clock stop bit to "0"), set sufficient time for oscillation to stabilize.

Oscillation Control

(1) Stop mode

If the STP instruction is executed, the internal clock ϕ stops at an "H" level, and XIN and XCIN oscillators stop. When the oscillation stabilizing time set after STP instruction released bit is "0," the prescaler 12 is set to "FF16" and timer 1 is set to "0116." When the oscillation stabilizing time set after STP instruction released bit is "1," set the sufficient time for oscillation of used oscillator to stabilize since nothing is set to the prescaler 12 and timer 1.

After STP instruction is released, the input of the prescaler 12 is connected to count source which had set at executing the STP instruction, and the output of the prescaler 12 is connected to timer 1. Set the timer 1 interrupt enable bit to disabled ("0") before executing the STP instruction. Oscillator restarts when an external interrupt is received, but the internal clock ϕ is not supplied to the CPU (remains at "H") until timer 1 underflows. The internal clock ϕ is supplied for the first time, when timer 1 underflows. Therefore make sure not to set the timer 1 interrupt request bit to "1" before the STP instruction stops the oscillator. When the oscillator is restarted by reset, apply "L" level to the $\overline{\text{RESET}}$ pin until the oscillation is stable since a wait time will not be generated.

(2) Wait mode

If the WIT instruction is executed, the internal clock ϕ stops at an "H" level, but the oscillator does not stop. The internal clock ϕ restarts when an interrupt is received or reset. Since the oscillator does not stop, normal operation can be started immediately after the clock is restarted.

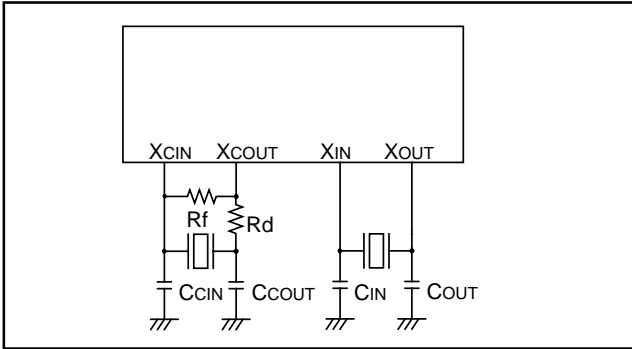

Fig. 80 Ceramic resonator circuit

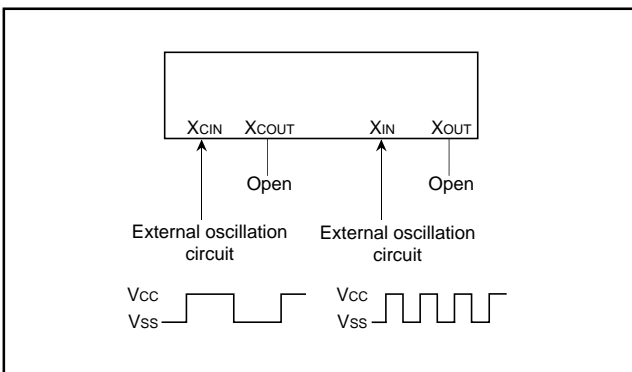

Fig. 81 External clock input circuit

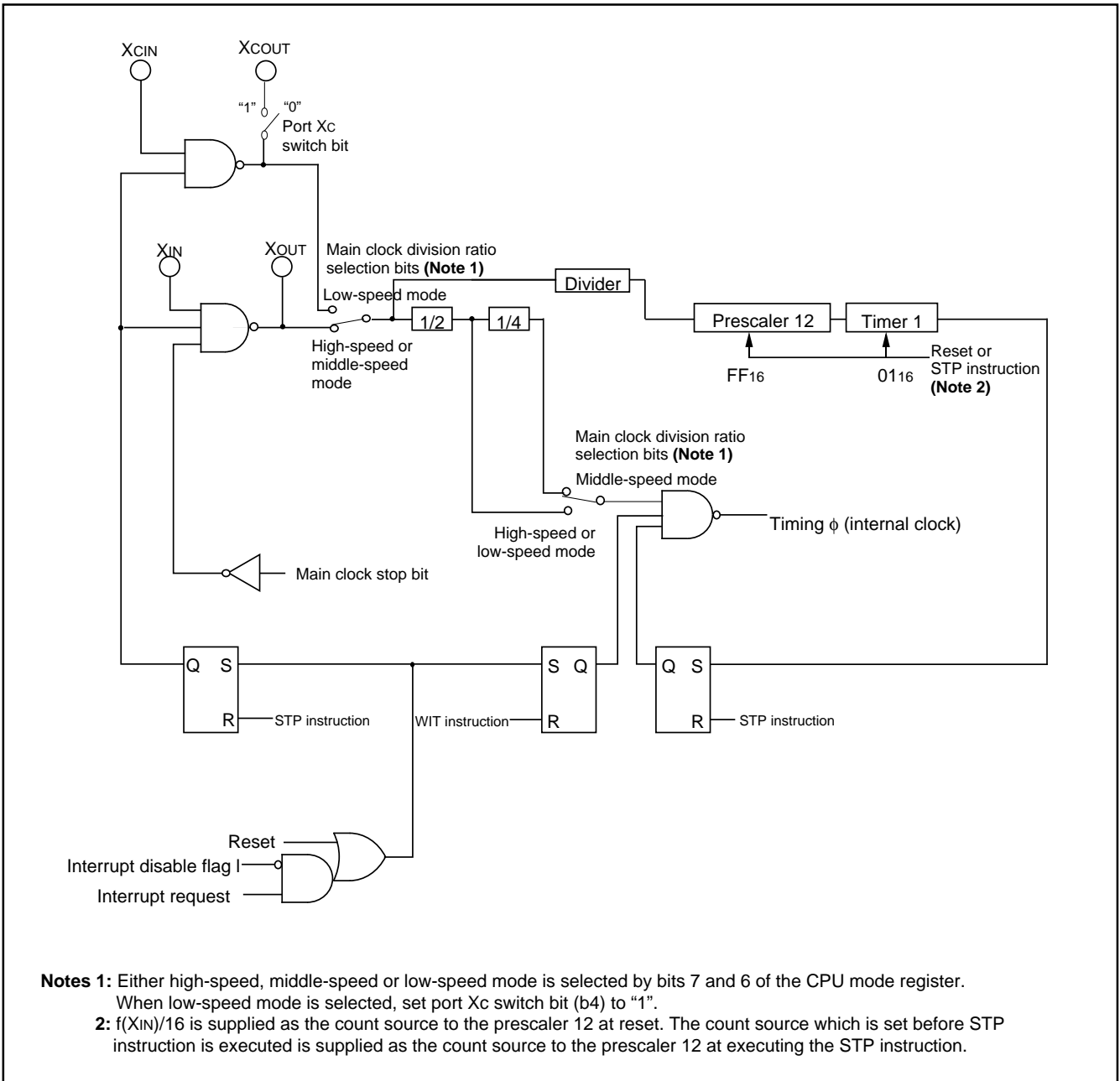
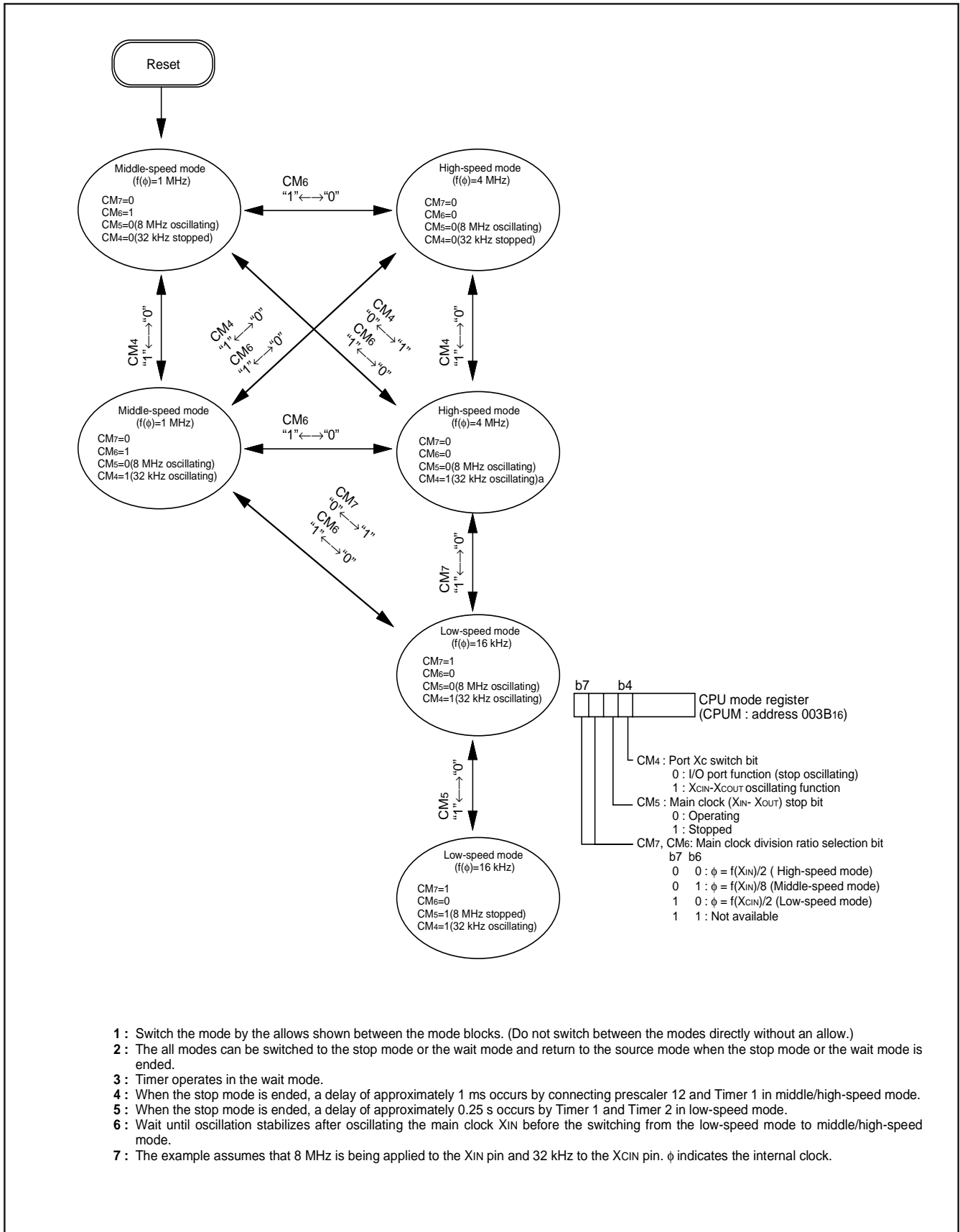

Fig. 82 System clock generating circuit block diagram (Single-chip mode)



- 1 : Switch the mode by the allows shown between the mode blocks. (Do not switch between the modes directly without an allow.)
- 2 : The all modes can be switched to the stop mode or the wait mode and return to the source mode when the stop mode or the wait mode is ended.
- 3 : Timer operates in the wait mode.
- 4 : When the stop mode is ended, a delay of approximately 1 ms occurs by connecting prescaler 12 and Timer 1 in middle/high-speed mode.
- 5 : When the stop mode is ended, a delay of approximately 0.25 s occurs by Timer 1 and Timer 2 in low-speed mode.
- 6 : Wait until oscillation stabilizes after oscillating the main clock XIN before the switching from the low-speed mode to middle/high-speed mode.
- 7 : The example assumes that 8 MHz is being applied to the XIN pin and 32 kHz to the XCIN pin. φ indicates the internal clock.

Fig. 83 State transitions of system clock

FLASH MEMORY MODE

The 3803/3804 group has the flash memory mode in addition to the normal operation mode (microcomputer mode). The user can use this mode to perform read, program, and erase operations for the internal flash memory.

The 3803/3804 group has three modes the user can choose: the parallel input/output and serial input/output mode, where the flash memory is handled by using the external programmer, and the CPU reprogramming mode, where the flash memory is handled by the central processing unit (CPU). The following explains these modes.

(1) Flash memory mode 1 (parallel I/O mode)

The parallel I/O mode can be selected by connecting wires as shown in Figures 84 and supplying power to the VCC and VPP pins. In this mode, the M38039FFSP/FP operates as an equivalent of MITSUBISHI's CMOS flash memory M5M28F101. However, because the M38039FFSP/FP's internal memory has a capacity of 60 Kbytes, programming is available for addresses 01000₁₆ to 0FFFF₁₆, and make sure that the data in addresses 00000₁₆ to 00FFF₁₆ and addresses 10000₁₆ to 1FFFF₁₆ are FF₁₆. Note also that the M38039FFSP/FP does not contain a facility to read out a device identification code by applying a high voltage to address input (A9). Be careful not to erratically set program conditions when using a general-purpose PROM programmer.

Table 14 shows the pin assignments when operating in the parallel input/output mode.

Table 14 Pin assignments of M38039FFSP/FP when operating in the parallel input/output mode

	M38039FFSP/FP	M5M28F101
VCC	VCC	VCC
VPP	CNVSS	VPP
VSS	VSS	VSS
Address input	Ports P0, P1, P3 ₁	A0–A16
Data I/O	Port P2	D0–D7
CE	P3 ₆	CE
OE	P3 ₇	OE
WE	P3 ₃	WE

Functional Outline (parallel input/output mode)

In the parallel input/output mode, the 3803/3804 group allow the user to choose an operation mode between the read-only mode and the read/write mode (software command control mode) depending on the voltage applied to the VPP pin. When VPP = VPP_L, the read-only mode is selected, and the user can choose one of three states (e.g., read, output disable, or standby) depending on inputs to the CE, OE, and WE pins. When VPP = VPP_H, the read/write mode is selected, and the user can choose one of four states (e.g., read, output disable, standby, or write) depending on inputs to the CE, OE, and WE pins. Table 15 shows assignment states of control input and each state.

● **Read**

The microcomputer enters the read state by driving the CE, and OE pins low and the WE pin high; and the contents of memory corresponding to the address to be input to address input pins (A0–A16) are output to the data input/output pins (D0–D7).

● **Output disable**

The microcomputer enters the output disable state by driving the CE pin low and the WE and OE pins high; and the data input/output pins enter the floating state.

● **Standby**

The microcomputer enters the standby state by driving the CE pin high. the 3803/3804 group is placed in a power-down state consuming only a minimum supply current. At this time, the data input/output pins enter the floating state.

● **Write**

The microcomputer enters the write state by driving the VPP pin high (VPP = VPP_H) and then the WE pin low when the CE pin is low and the OE pin is high. In this state, software commands can be input from the data input/output pins, and the user can choose program or erase operation depending on the contents of this software command.

Table 15 Assignment states of control input and each state

Mode	State	Pin				
		CE	OE	WE	VPP	Data I/O
Read-only	Read	V _{IL}	V _{IL}	V _{IH}	V _{PLL}	Output
	Output disable	V _{IL}	V _{IH}	V _{IH}	V _{PLL}	Floating
	Standby	V _{IH}	×	×	V _{PLL}	Floating
Read/Write	Read	V _{IL}	V _{IL}	V _{IH}	V _{PPH}	Output
	Output disable	V _{IL}	V _{IH}	V _{IH}	V _{PPH}	Floating
	Standby	V _{IH}	×	×	V _{PPH}	Floating
	Write	V _{IL}	V _{IH}	V _{IL}	V _{PPH}	Input

Note: × can be V_{IL} or V_{IH}.

Table 16 Pin description (flash memory parallel I/O mode)

Pin	Name	Input /Output	Functions
VCC, VSS	Power supply	—	Supply 5 V \pm 10 % to VCC and 0 V to VSS.
CNVSS	VPP input	Input	Connect to 5 V \pm 10 % in read-only mode, connect to 11.7 V to 12.6 V in read/write mode.
RESET	Reset input	Input	Connect to VSS.
XIN	Clock input	Input	Connect a ceramic resonator between XIN and XOUT.
XOUT	Clock output	Output	
AVSS	Analog supply input	—	Connect to VSS.
VREF	Reference voltage input	Input	Connect to VSS.
P00–P07	Address input (A0–A7)	Input	Port P0 functions as 8-bit address input (A0–A7).
P10–P17	Address input (A8–A15)	Input	Port P1 functions as 8-bit address input (A8–A15).
P20–P27	Data I/O (D0–D7)	I/O	Function as 8-bit data's I/O pins (D0–D7).
P30–P37	Control signal input	Input	P37, P36 and P33 function as the OE, CE and WE input pins respectively. P31 functions as the A16 input pin. Connect P30 and P32 to VSS. Input "H" or "L" to P34, P35, or keep them open.
P40–P47	Input port P4	Input	Connect P44, P46 to VSS. Input "H" or "L" to P40 - P43, P45, P47, or keep them open.
P50–P57	Input port P5	Input	Input "H" or "L", or keep them open.
P60–P67	Input port P6	Input	Input "H" or "L", or keep them open.

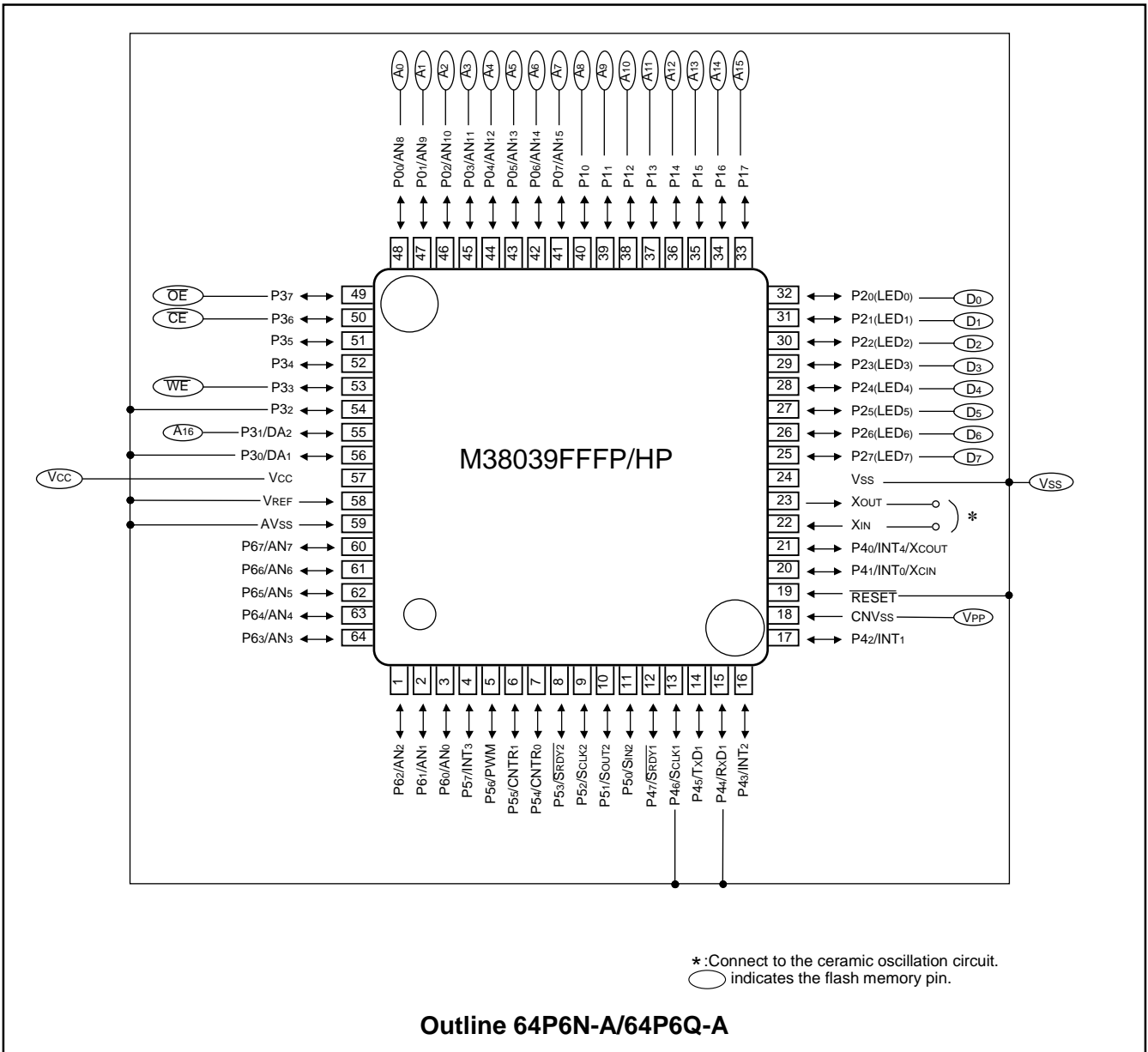

Fig. 84 Pin connection of M38039FFFP/HP when operating in parallel input/output mode

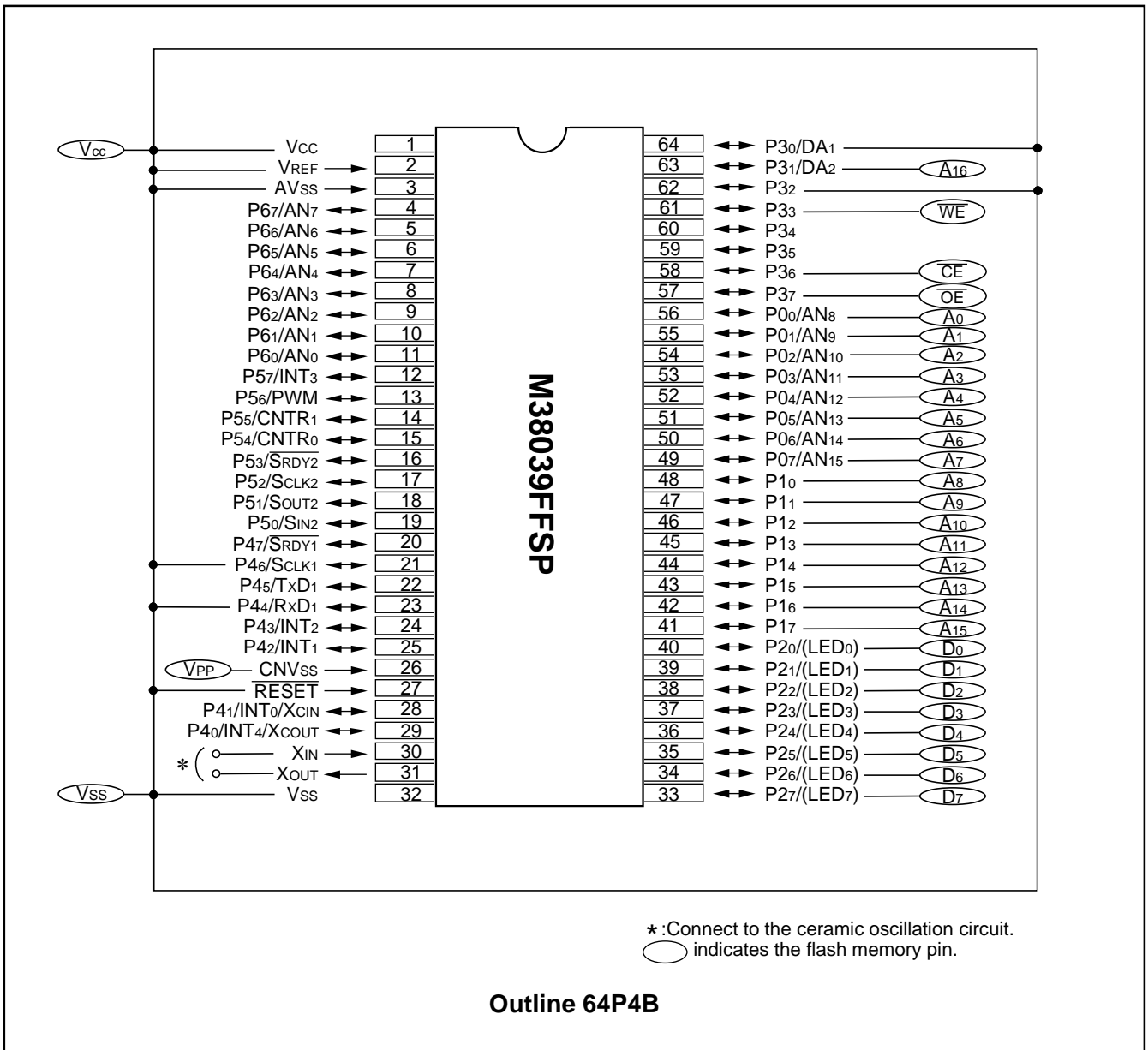

Fig. 85 Pin connection of M38039FFSP when operating in parallel input/output mode

Read-only Mode

The microcomputer enters the read-only mode by applying V_{PPL} to the V_{PP} pin. In this mode, the user can input the address of a memory location to be read and the control signals at the timing

shown in Figure 86, and the M38039FFSP/FP will output the contents of the user's specified address from data I/O pin to the external. In this mode, the user cannot perform any operation other than read.

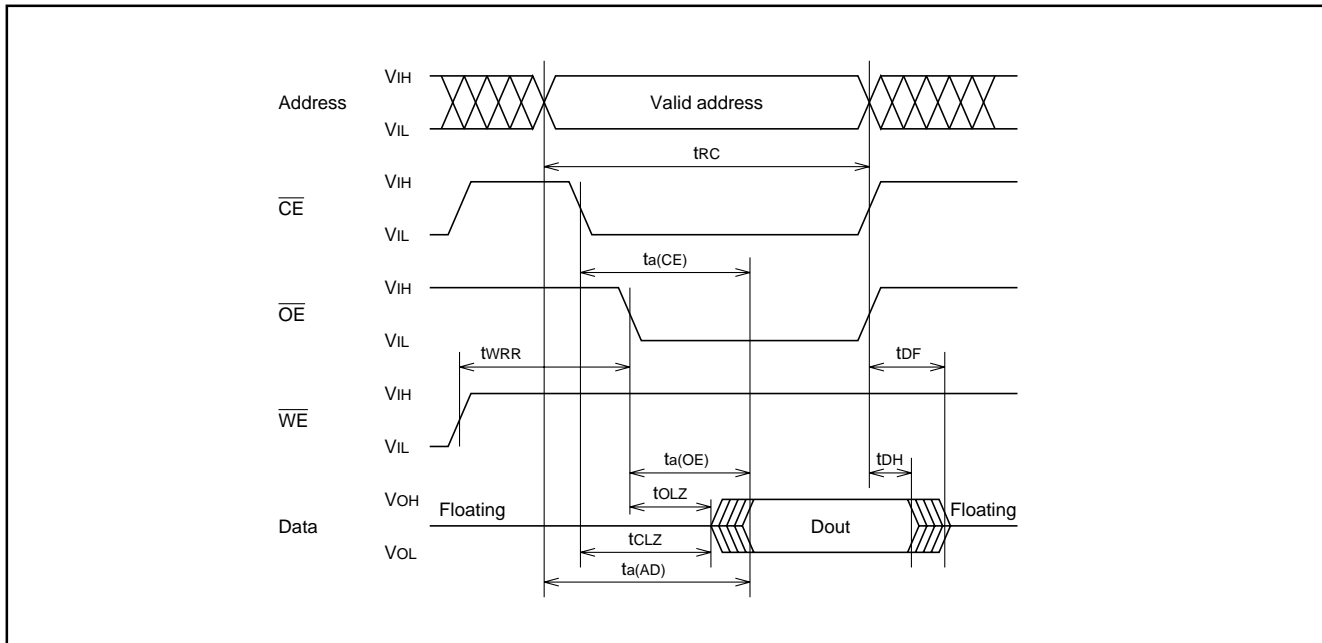

Fig. 86 Read timing

Read/Write Mode

The microcomputer enters the read/write mode by applying V_{PPH} to the V_{PP} pin. In this mode, the user must first input a software command to choose the operation (e. g., read, program, or erase) to be performed on the flash memory (this is called the first cycle), and then input the information necessary for execution of the command (e.g, address and data) and control signals (this is called the second cycle). When this is done, the 3803/3804 group executes the specified operation.

Table 17 shows the software commands and the input/output information in the first and the second cycles. The input address is latched internally at the falling edge of the \overline{WE} input; software commands and other input data are latched internally at the rising edge of the \overline{WE} input.

The following explains each software command. Refer to Figures 87 to 89 for details about the signal input/output timings.

Table 17 Software command (Parallel input/output mode)

Symbol	First cycle		Second cycle	
	Address input	Data input	Address input	Data I/O
Read	×	00 ₁₆	Read address	Read data (Output)
Program	×	40 ₁₆	Program address	Program data (Input)
Program verify	×	C0 ₁₆	×	Verify data (Output)
Erase	×	20 ₁₆	×	20 ₁₆ (Input)
Erase verify	Verify address	A0 ₁₆	×	Verify data (Output)
Reset	×	FF ₁₆	×	FF ₁₆ (Input)
Device identification	×	90 ₁₆	ADI	DDI (Output)

Note: ADI = Device identification address : manufacturer's code 00000₁₆, device code 00001₁₆
 DDI = Device identification data : manufacturer's code 1C₁₆, device code D0₁₆
 X can be VIL or VIH.

● Read command

The microcomputer enters the read mode by inputting command code "0016" in the first cycle. The command code is latched into the internal command latch at the rising edge of the WE input. When the address of a memory location to be read is input in the second cycle, with control signals input at the timing shown in Figure 87, the 3803/3804 group outputs the contents of the specified address from the data I/O pins to the external.

The read mode is retained until any other command is latched into the command latch. Consequently, once the 3803/3804 group enters the read mode, the user can read out the successive memory contents simply by changing the input address and executing the second cycle only. Any command other than the read command must be input beginning from its command code over again each time the user execute it. The contents of the command latch immediately after power-on is 0016.

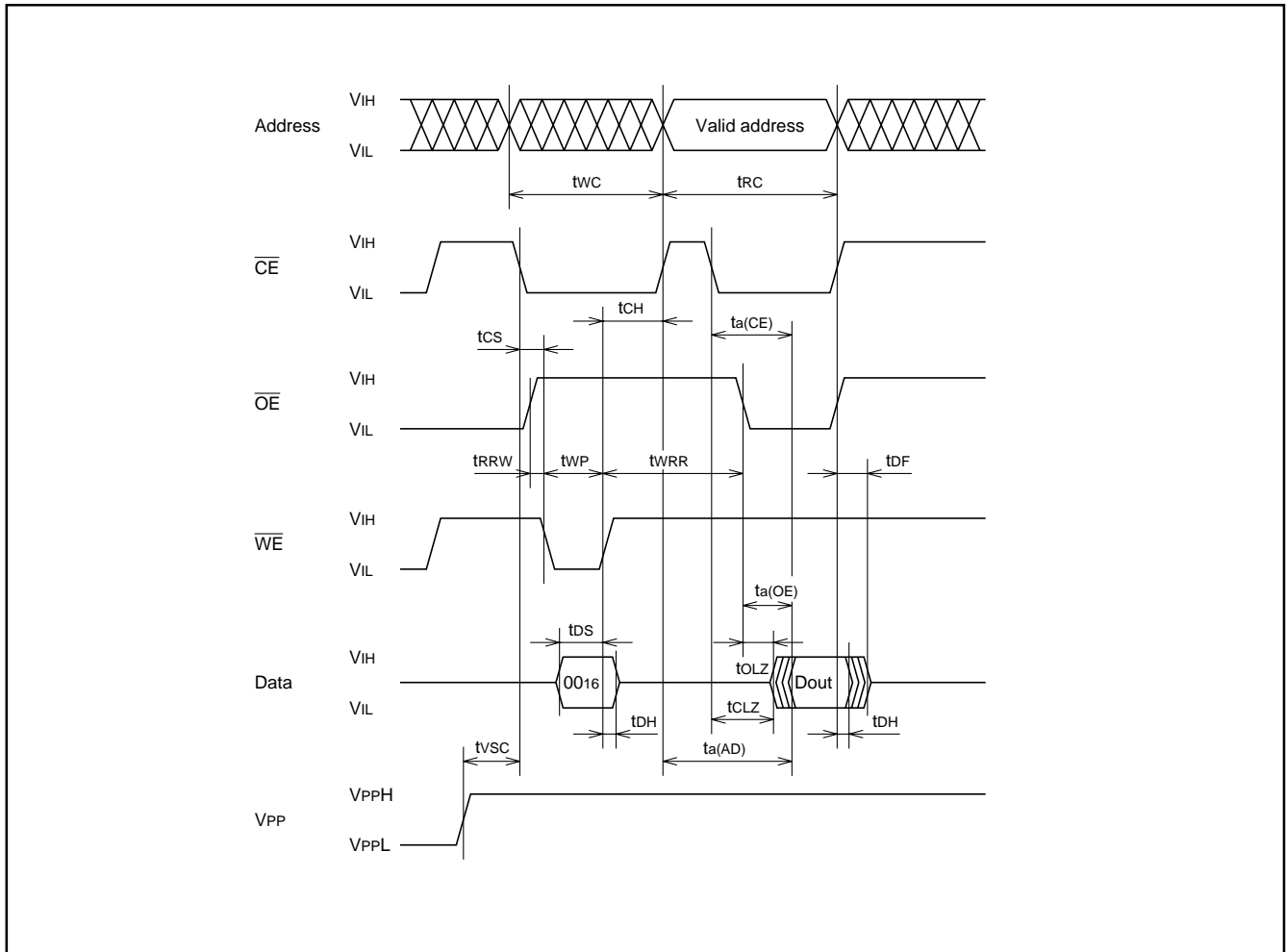

Fig. 87 Timings during reading

● Program command

The microcomputer enters the program mode by inputting command code "4016" in the first cycle. The command code is latched into the internal command latch at the rising edge of the WE input. When the address which indicates a program location and data is input in the second cycle, the 3803/3804 group internally latches the address at the falling edge of the WE input and the data at the rising edge of the WE input. The 3803/3804 group starts programming at the rising edge of the WE input in the second cycle and finishes programming within 10 μs as measured by its internal timer. Programming is performed in units of bytes.

Note: A programming operation is not completed by executing the program command once. Always be sure to execute a program verify command after executing the program command. When the failure is found in this verification, the user must repeatedly execute the program command until the pass. Refer to Figure 90 for the programming flowchart.

● Program verify command

The microcomputer enters the program verify mode by inputting command code "C016" in the first cycle. This command is used to verify the programmed data after executing the program command. The command code is latched into the internal command latch at the rising edge of the WE input. When control signals are input in the second cycle at the timing shown in Figure 88, the 3803/3804 group outputs the programmed address's contents to the external. Since the address is internally latched when the program command is executed, there is no need to input it in the second cycle.

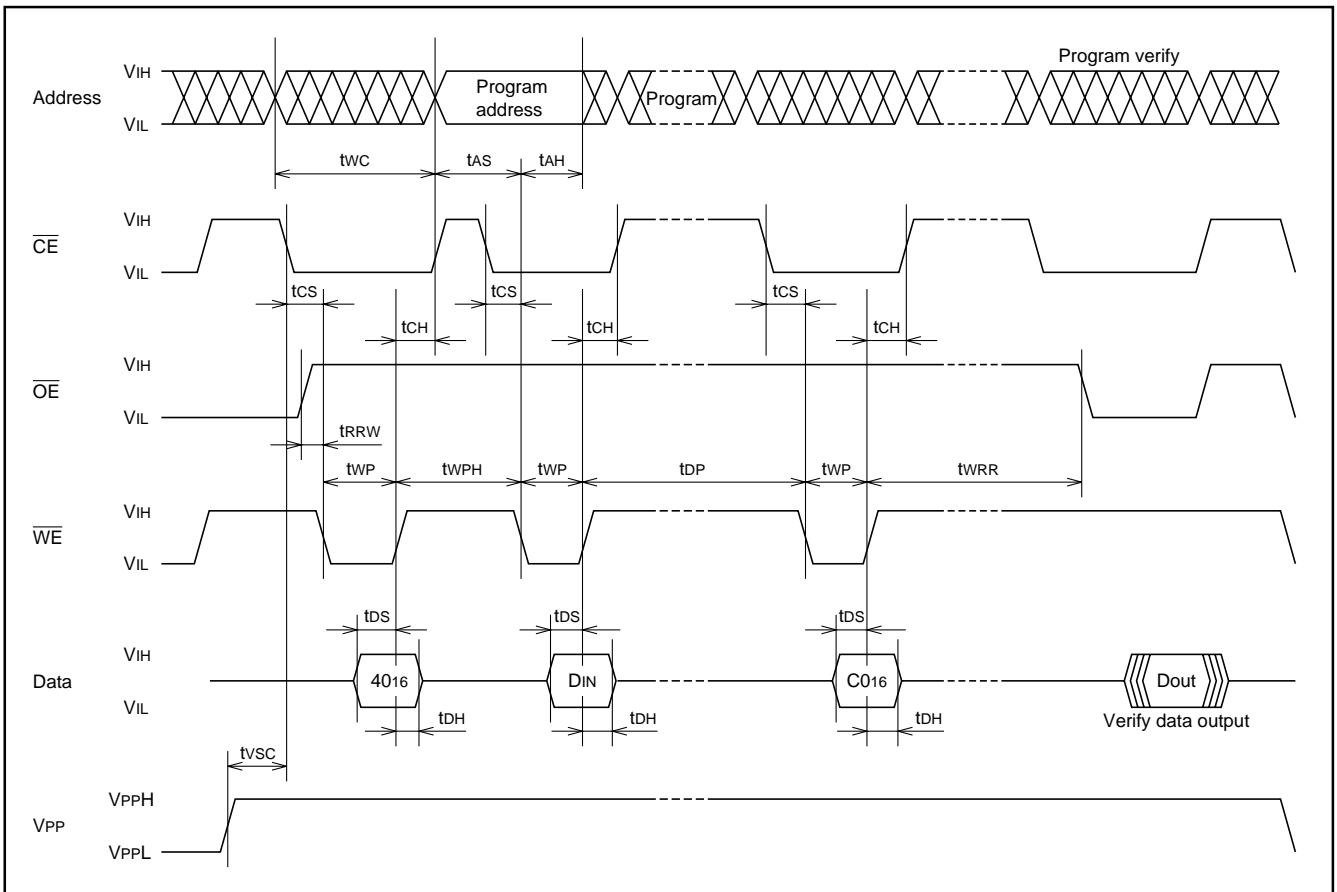

Fig. 88 Input/output timings during programming (Verify data is output at the same timing as for read.)

● Erase command

The erase command is executed by inputting command code 20₁₆ in the first cycle and command code 20₁₆ again in the second cycle. The command code is latched into the internal command latch at the rising edges of the \overline{WE} input in the first cycle and in the second cycle, respectively. The erase operation is initiated at the rising edge of the \overline{WE} input in the second cycle, and the memory contents are collectively erased within 9.5 ms as measured by the internal timer. Note that data 00₁₆ must be written to all memory locations before executing the erase command.

Note: An erase operation is not completed by executing the erase command once. Always be sure to execute an erase verify command after executing the erase command. When the failure is found in this verification, the user must repeatedly execute the erase command until the pass. Refer to Figure 90 for the erase flowchart.

● Erase verify command

The user must verify the contents of all addresses after completing the erase command. The microcomputer enters the erase verify mode by inputting the verify address and command code A0₁₆ in the first cycle. The address is internally latched at the falling edge of the \overline{WE} input, and the command code is internally latched at the rising edge of the \overline{WE} input. When control signals are input in the second cycle at the timing shown in Figure 89, the 3803/3804 group outputs the contents of the specified address to the external.

Note: If any memory location where the contents have not been erased is found in the erase verify operation, execute the operation of “erase → erase verify” over again. In this case, however, the user does not need to write data 00₁₆ to memory locations before erasing.

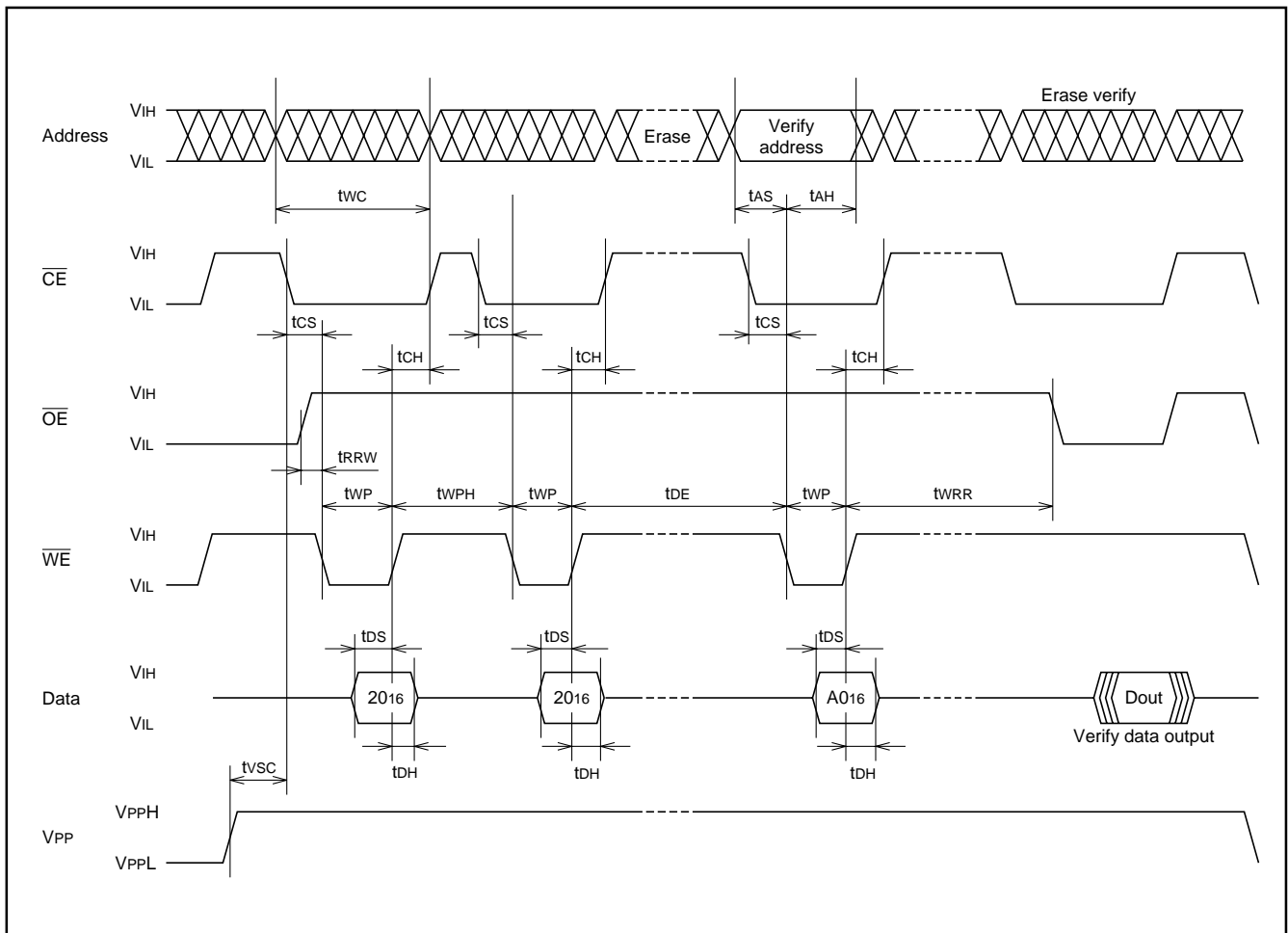

Fig. 89 Input/output timings during erasing (verify data is output at the same timing as for read.)

● Reset command

The reset command provides a means of stopping execution of the erase or program command safely. If the user inputs command code FF₁₆ in the second cycle after inputting the erase or program command in the first cycle and again input command code FF₁₆ in the third cycle, the erase or program command is disabled (i.e., reset), and the 3803/3804 group is placed in the read mode. If the reset command is executed, the contents of the memory does not change.

● Device identification code command

By inputting command code 90₁₆ in the first cycle, the user can read out the device identification code. The command code is latched into the internal command latch at the rising edge of the \overline{WE} input. At this time, the user can read out manufacture's code 1C₁₆ (i.e., MITSUBISHI) by inputting 00000₁₆ to the address input pins in the second cycle; the user can read out device code D0₁₆ (i. e., 1M-bit flash memory) by inputting 00001₁₆.

These command and data codes are input/output at the same timing as for read.

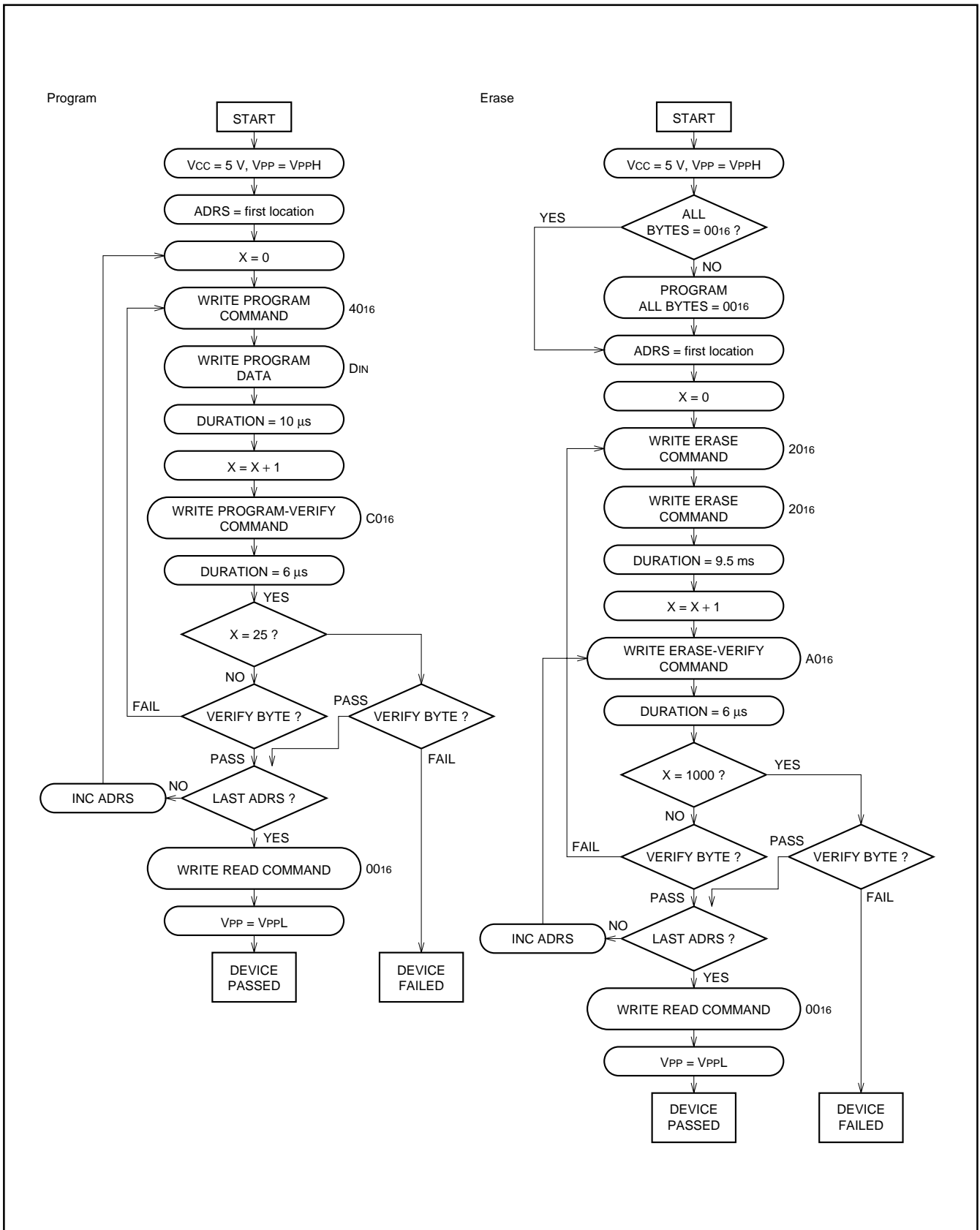

Fig. 90 Programming/Erasing algorithm flow chart

Table 18 DC ELECTRICAL CHARACTERISTICS ($T_a = 25\text{ }^\circ\text{C}$, $V_{CC} = 5\text{ V} \pm 10\%$, unless otherwise noted)

Symbol	Parameter	Test conditions	Limits			Unit
			Min.	Typ.	Max.	
ISB1	VCC supply current (at standby)	$V_{CC} = 5.5\text{ V}$, $\overline{CE} = V_{IH}$			1	mA
ISB2		$V_{CC} = 5.5\text{ V}$, $\overline{CE} = V_{CC} \pm 0.2\text{ V}$			100	μA
ICC1	VCC supply current (at read)	$V_{CC} = 5.5\text{ V}$, $\overline{CE} = V_{IL}$, $t_{RC} = 150\text{ ns}$, $I_{OUT} = 0\text{ mA}$			15	mA
ICC2	VCC supply current (at program)	$V_{PP} = V_{PPH}$			15	mA
ICC3	VCC supply current (at erase)	$V_{PP} = V_{PPH}$			15	mA
IPP1	VPP supply current (at read)	$0 \leq V_{PP} \leq V_{CC}$			10	μA
		$V_{CC} < V_{PP} \leq V_{CC} + 1.0\text{ V}$			100	μA
		$V_{PP} = V_{PPH}$			100	μA
IPP2	VPP supply current (at program)	$V_{PP} = V_{PPH}$			30	mA
IPP3	VPP supply current (at erase)	$V_{PP} = V_{PPH}$			30	mA
VIL	"L" input voltage		0		0.8	V
VIH	"H" input voltage		2.0		V_{CC}	V
VOL	"L" output voltage	$I_{OL} = 2.1\text{ mA}$			0.45	V
VOH1	"H" output voltage	$I_{OH} = -400\text{ }\mu\text{A}$	2.4			V
VOH2		$I_{OH} = -100\text{ }\mu\text{A}$	$V_{CC} - 0.4$			V
VPP_L	VPP supply voltage (read only)		V_{CC}		$V_{CC} + 1.0$	V
VPP_H	VPP supply voltage (read/write)		11.7	12.0	12.6	V

AC ELECTRICAL CHARACTERISTICS ($T_a = 25\text{ }^\circ\text{C}$, $V_{CC} = 5\text{ V} \pm 10\%$, unless otherwise noted)

Table 19 Read-only mode

Symbol	Parameter	Limits		Unit
		Min.	Max.	
t_{RC}	Read cycle time	150		ns
$t_{a(AD)}$	Address access time		150	ns
$t_{a(\overline{CE})}$	\overline{CE} access time		150	ns
$t_{a(\overline{OE})}$	\overline{OE} access time		55	ns
t_{CLZ}	Output enable time (after \overline{CE})	0		ns
t_{OLZ}	Output enable time (after \overline{OE})	0		ns
t_{DF}	Output floating time (after \overline{OE})		35	ns
t_{DH}	Output valid time (after \overline{CE} , \overline{OE} , address)	0		ns
t_{WRR}	Write recovery time (before read)	6		μs

Table 20 Read/Write mode

Symbol	Parameter	Limits		Unit
		Min.	Max.	
t_{WC}	Write cycle time	150		ns
t_{AS}	Address set up time	0		ns
t_{AH}	Address hold time	60		ns
t_{DS}	Data setup time	50		ns
t_{DH}	Data hold time	10		ns
t_{WRR}	Write recovery time (before read)	6		μs
t_{RRW}	Read recovery time (before write)	0		μs
t_{CS}	\overline{CE} setup time	20		ns
t_{CH}	\overline{CE} hold time	0		ns
t_{WP}	Write pulse width	60		ns
t_{WPH}	Write pulse waiting time	20		ns
t_{DP}	Program time	10		μs
t_{DE}	Erase time	9.5		ms
t_{VSC}	VPP setup time	1		μs

Note: Read timing of Read/Write mode is same as Read-only mode.

(2) Flash memory mode 2 (serial I/O mode)

The flash memory version of the 3803/3804 group has a function to serially input/output the software commands, addresses, and data required for operation on the internal flash memory (e. g., read, program, and erase) using only a few pins. This is called the serial I/O (input/output) mode. This mode can be selected by driving the SDA (serial data input/output), SCLK (serial clock input),

and OE pins high after connecting wires as shown in Figures 91 and powering on the VCC pin and then applying VPPH to the VPP pin.

In the serial I/O mode, the user can use six types of software commands: read, program, program verify, erase, erase verify and error check.

Serial input/output is accomplished synchronously with the clock, beginning from the LSB (LSB first).

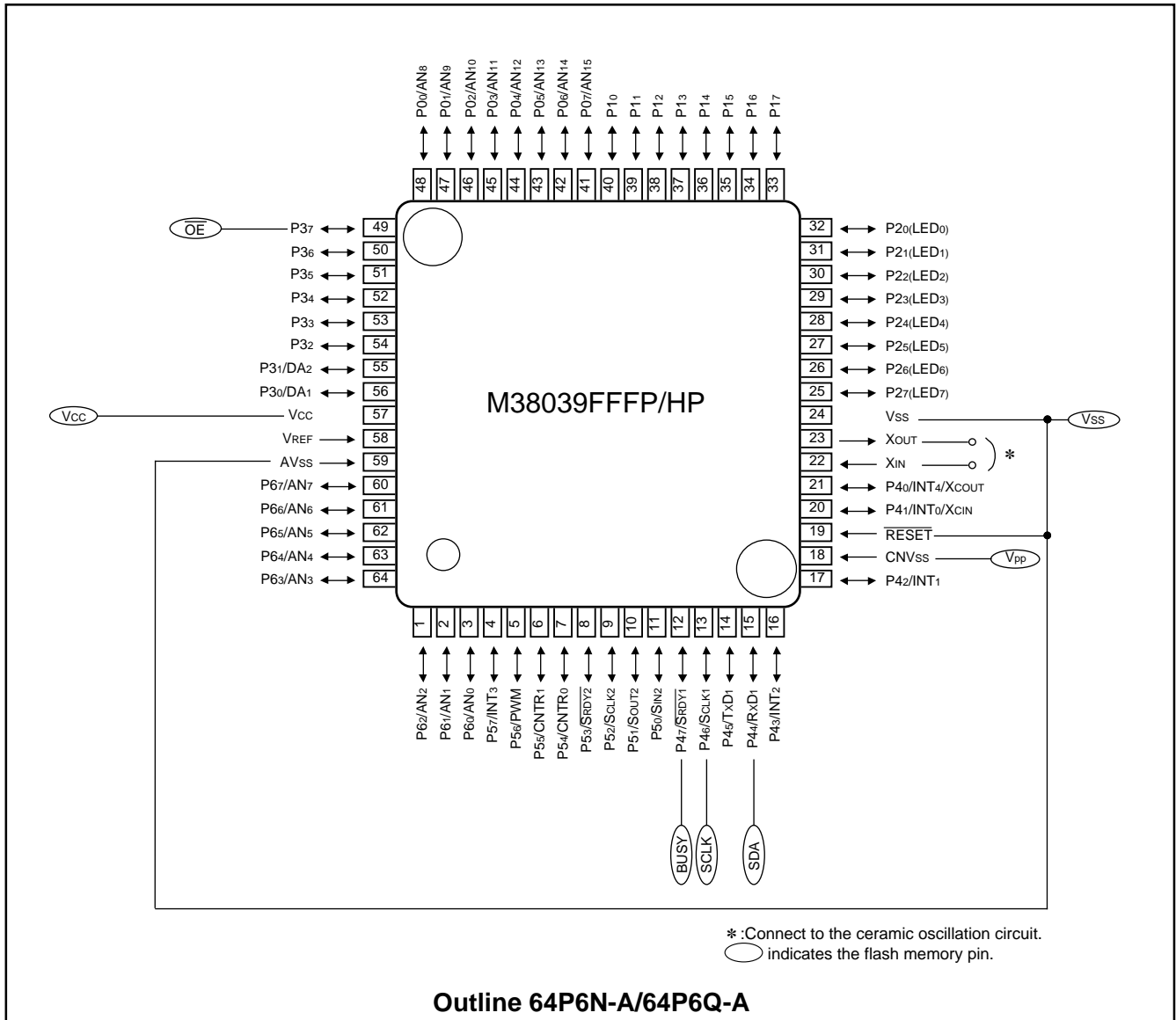

Fig. 91 Pin connection of M38039FFFP/HP when operating in serial I/O mode

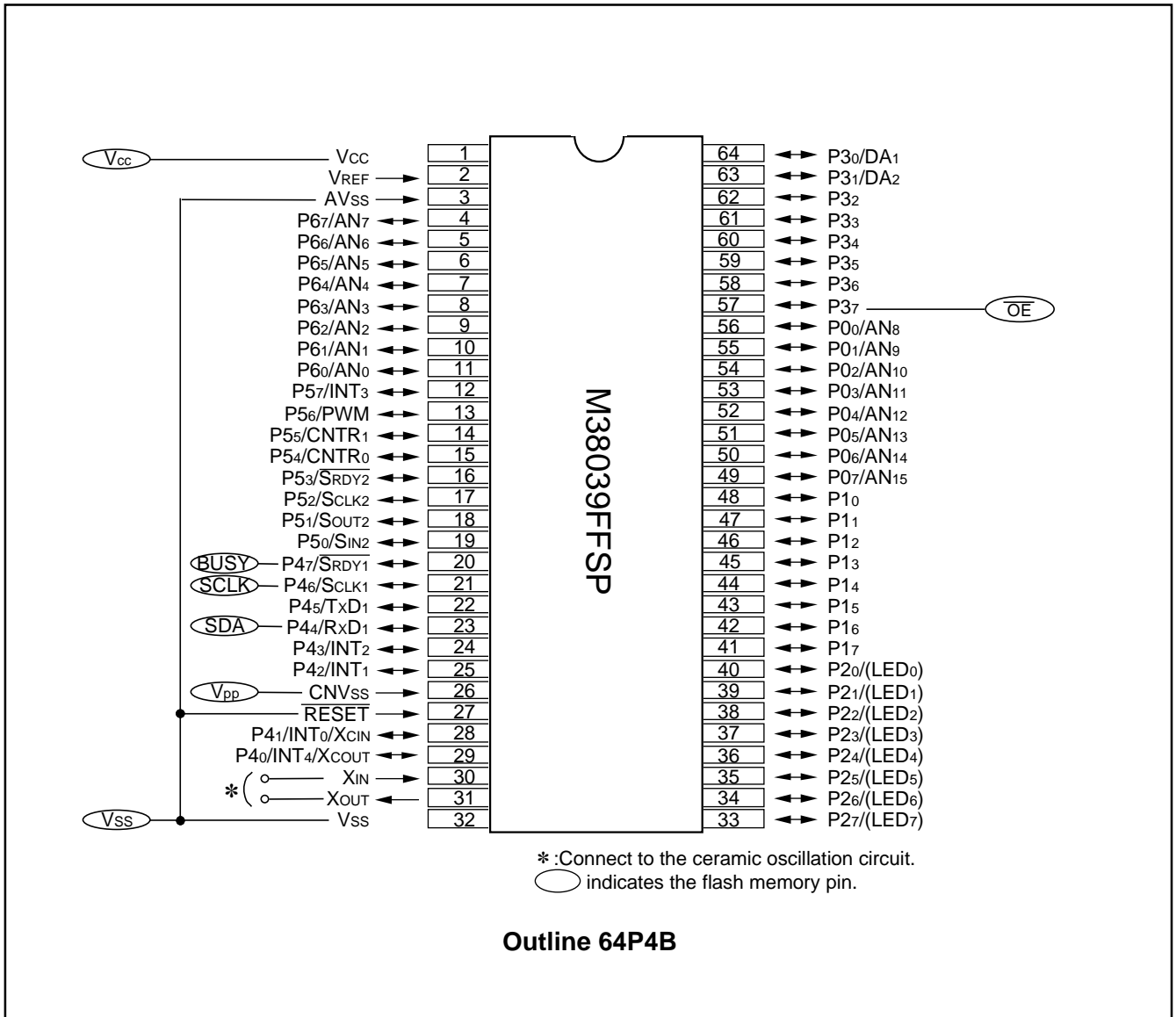

Fig. 92 Pin connection of M38039FFSP when operating in serial I/O mode

Table 21 Pin description (flash memory serial I/O mode)

Pin	Name	Input /Output	Functions
VCC, VSS	Power supply	—	Supply 5 V ± 10 % to VCC and 0 V to VSS.
CNVSS	VPP input	Input	Connect to 11.7 V to 12.6 V.
RESET	Reset input	Input	Connect to VSS.
XIN	Clock input	Input	Connect a ceramic resonator between XIN and XOUT.
XOUT	Clock output	Output	
AVSS	Analog supply input	—	Connect to VSS.
VREF	Reference voltage input	Input	Input an arbitrary level between the range of VSS and VCC.
P00–P07	Input port P0	Input	Input “H” or “L”, or keep them open.
P10–P17	Input port P1	Input	Input “H” or “L”, or keep them open.
P20–P27	Input port P2	Input	Input “H” or “L”, or keep them open.
P30–P36	Input port P3	Input	Input “H” or “L”, or keep them open.
P37	Control signal input	Input	OE input pin
P40–P43, P45	Input port P4	Input	Input “H” or “L” to P40 - P43, P45, or keep them open.
P44	SDA I/O	I/O	This pin is for serial data I/O.
P46	SCLK input	Input	This pin is for serial clock input.
P47	BUSY output	Output	This pin is for BUSY signal output.
P50–P57	Input port P5	Input	Input “H” or “L”, or keep them open.
P60–P67	Input port P6	Input	Input “H” or “L”, or keep them open.

Functional Outline (serial I/O mode)

In the serial I/O mode, data is transferred synchronously with the clock using serial input/output. The input data is read from the SDA pin into the internal circuit synchronously with the rising edge of the serial clock pulse; the output data is output from the SDA pin synchronously with the falling edge of the serial clock pulse. Data is transferred in units of eight bits.

In the first transfer, the user inputs the command code. This is followed by address input and data input/output according to the contents of the command. Table 22 shows the software commands used in the serial I/O mode. The following explains each software command.

Table 22 Software command (serial I/O mode)

Command \ Number of transfers	First command code input	Second	Third	Fourth
Read	00 ₁₆	Read address L (Input)	Read address H (Input)	Read data (Output)
Program	40 ₁₆	Program address L (Input)	Program address H (Input)	Program data (Input)
Program verify	C0 ₁₆	Verify data (Output)	—————	—————
Erase	20 ₁₆	20 ₁₆ (Input)	—————	—————
Erase verify	A0 ₁₆	Verify address L (Input)	Verify address H (Input)	Verify data (Output)
Error check	80 ₁₆	Error code (Output)	—————	—————

● **Read command**

Input command code 00₁₆ in the first transfer. Proceed and input the low-order 8 bits and the high-order 8 bits of the address and pull the \overline{OE} pin low. When this is done, the 3803/3804 group reads out the contents of the specified address, and then latches it into

the internal data latch. When the \overline{OE} pin is released back high and serial clock is input to the SCLK pin, the read data that has been latched into the data latch is serially output from the SDA pin.

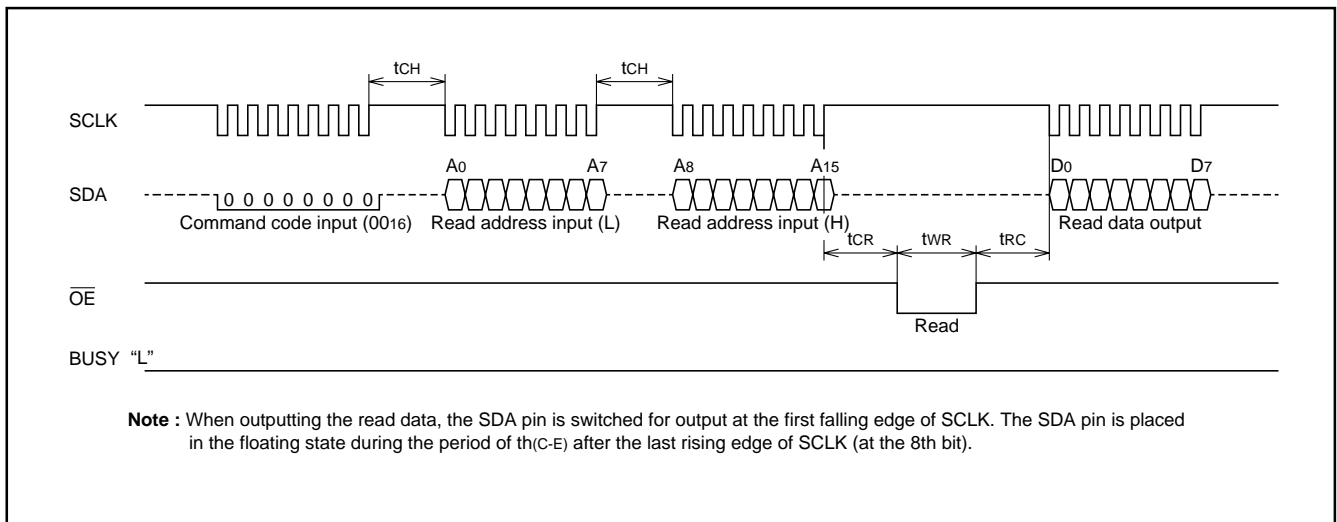

Fig. 93 Timings during reading

● Program command

Input command code 40₁₆ in the first transfer. Proceed and input the low-order 8 bits and the high-order 8 bits of the address and then program data. Programming is initiated at the last rising edge of the serial clock during program data transfer. The BUSY pin is driven high during program operation. Programming is completed within 10 μs as measured by the internal timer, and the BUSY pin is pulled low.

Note : A programming operation is not completed by executing the program command once. Always be sure to execute a program verify command after executing the program command. When the failure is found in the verification, the user must repeatedly execute the program command until the pass in the verification. Refer to Figure 90 for the programming flowchart.

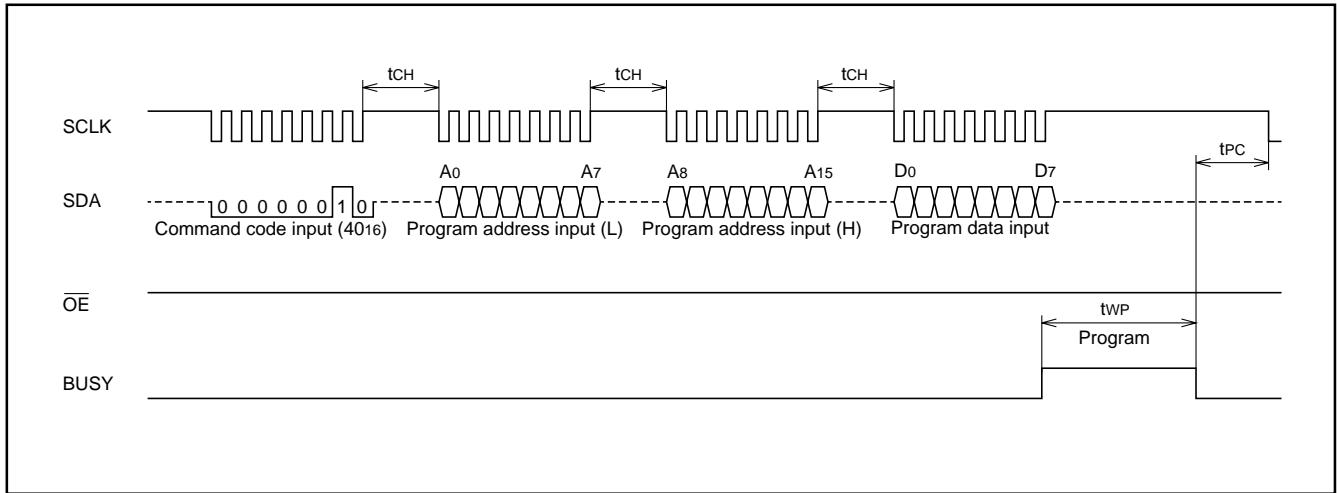
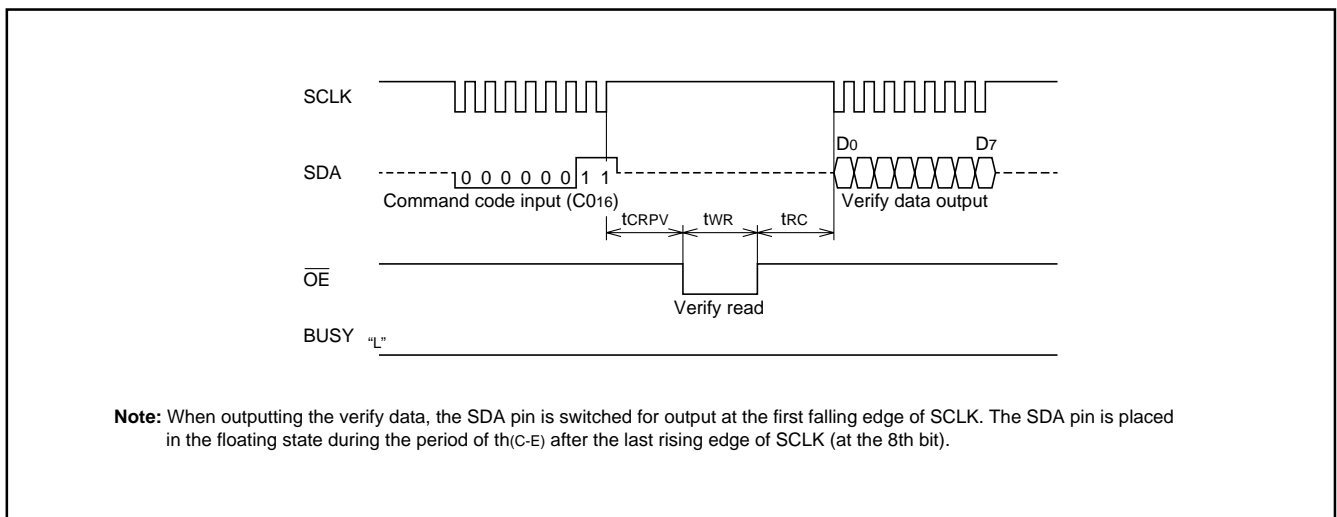

Fig. 94 Timings during programming

● Program verify command

Input command code C0₁₆ in the first transfer. Proceed and drive the OE pin low. When this is done, the 3803/3804 group verify-reads the programmed address's contents, and then latches it into

the internal data latch. When the OE pin is released back high and serial clock is input to the SCLK pin, the verify data that has been latched into the data latch is serially output from the SDA pin.



Note: When outputting the verify data, the SDA pin is switched for output at the first falling edge of SCLK. The SDA pin is placed in the floating state during the period of $t_{h(C-E)}$ after the last rising edge of SCLK (at the 8th bit).

Fig. 95 Timings during program verify

● Erase command

Input command code 20₁₆ in the first transfer and command code 20₁₆ again in the second transfer. When this is done, the 3803/3804 group executes an erase command. Erase is initiated at the last rising edge of the serial clock. The BUSY pin is driven high during the erase operation. Erase is completed within 9.5 ms as measured by the internal timer, and the BUSY pin is pulled low. Note that data 00₁₆ must be written to all memory locations before

executing the erase command.

Note: A erase operation is not completed by executing the erase command once. Always be sure to execute a erase verify command after executing the erase command. When the failure is found in the verification, the user must repeatedly execute the erase command until the pass in the verification. Refer to Figure 90 for the erase flowchart.

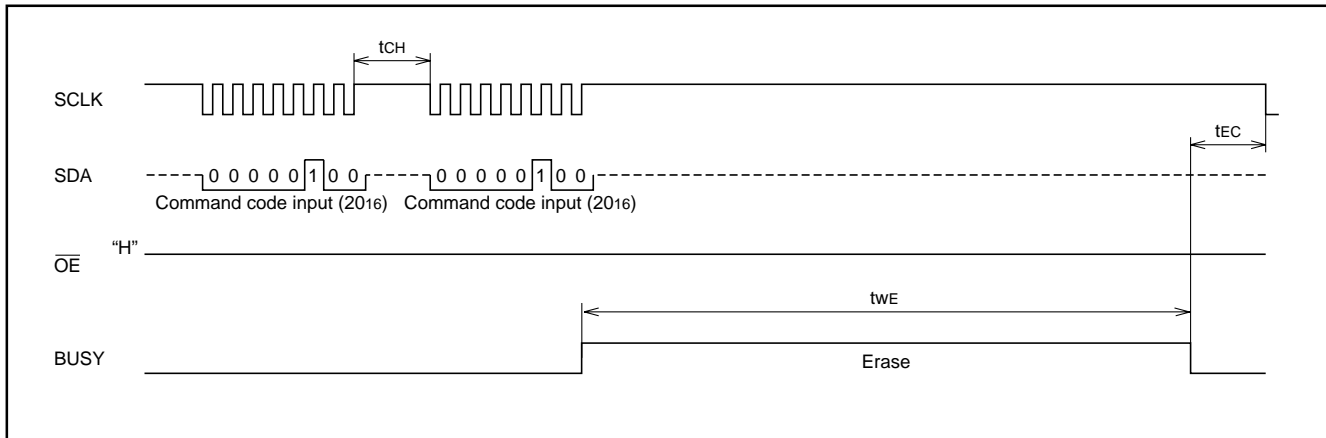

Fig. 96 Timings at erasing

● Erase verify command

The user must verify the contents of all addresses after completing the erase command. Input command code A0₁₆ in the first transfer. Proceed and input the low-order 8 bits and the high-order 8 bits of the address and pull the OE pin low. When this is done, the 3803/3804 group reads out the contents of the specified address, and then latches it into the internal data latch. When the OE pin is released back high and serial clock is input to the SCLK pin,

the verify data that has been latched into the data latch is serially output from the SDA pin.

Note: If any memory location where the contents have not been erased is found in the erase verify operation, execute the operation of “erase → erase verify” over again. In this case, however, the user does not need to write data 00₁₆ to memory locations before erasing.

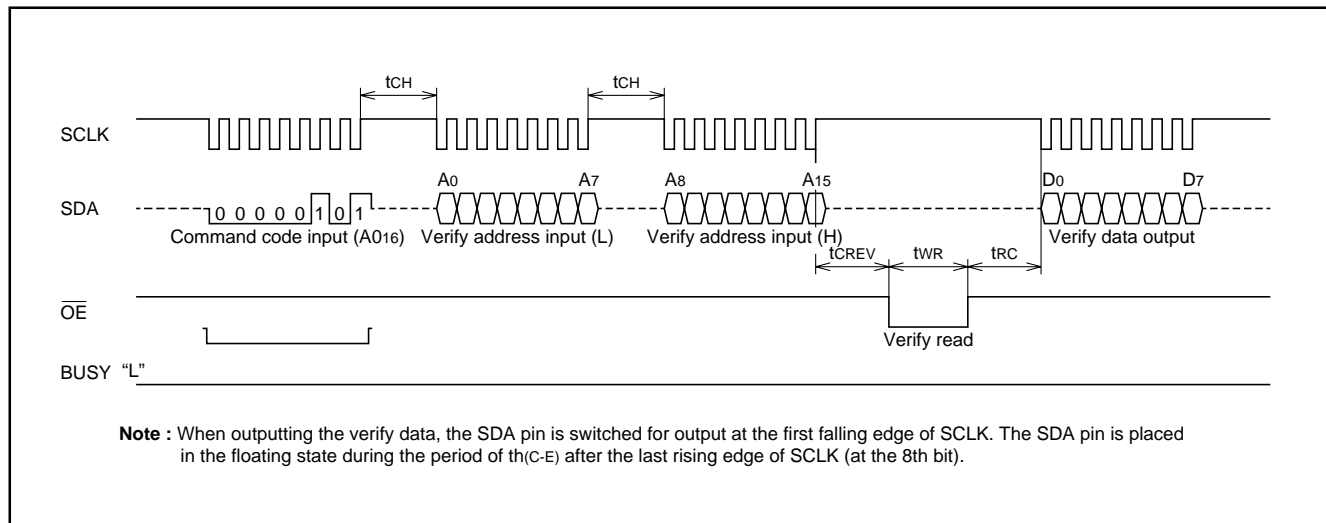

Note : When outputting the verify data, the SDA pin is switched for output at the first falling edge of SCLK. The SDA pin is placed in the floating state during the period of $t_{h(C-E)}$ after the last rising edge of SCLK (at the 8th bit).

Fig. 97 Timings during erase verify

● Error check command

Input command code 80₁₆ in the first transfer, and the 3803/3804 group outputs error information from the SDA pin, beginning at the next falling edge of the serial clock. If the LSB bit of the 8-bit error information is 1, it indicates that a command error has occurred. A command error means that some invalid commands other than commands shown in Table 22 has been input.

When a command error occurs, the serial communication circuit sets the corresponding flag and stops functioning to avoid an erroneous programming or erase. When being placed in this state, the serial communication circuit does not accept the subsequent serial clock and data (even including an error check command). Therefore, if the user wants to execute an error check command,

temporarily drop the VPP pin input to the VPPL level to terminate the serial input/output mode. Then, place the 3803/3804 group into the serial I/O mode back again. The serial communication circuit is reset by this operation and is ready to accept commands. The error flag alone is not cleared by this operation, so the user can examine the serial communication circuit's error conditions before reset. This examination is done by the first execution of an error check command after the reset. The error flag is cleared when the user has executed the error check command. Because the error flag is undefined immediately after power-on, always be sure to execute the error check command.

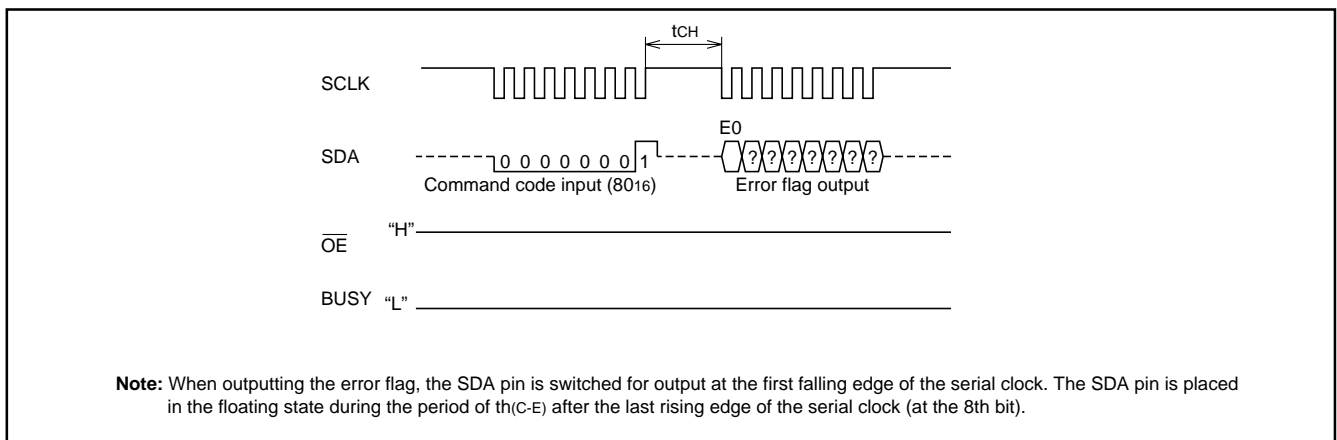

Fig. 98 Timings at error checking

DC ELECTRICAL CHARACTERISTICS (Ta = 25 °C, Vcc = 5 V ± 10 %, VPP = 11.7 V to 12.6 V, unless otherwise noted)

ICC, IPP-relevant standards during read, program, and erase are the same as in the parallel input/output mode. VIH, VIL, VOH, VOL, IiH, and IiL for the SCLK, SDA, BUSY, OE pins conform to the microcomputer modes.

Table 23 AC Electrical characteristics

(Ta = 25 °C, Vcc = 5 V ± 10 %, VPP = 11.7 V to 12.6 V, f(XIN) = 10 MHz, unless otherwise noted)

Symbol	Parameter	Limits		Unit
		Min.	Max.	
tCH	Serial transmission interval	500(Notes 1)		ns
tCR	Read waiting time after transmission	500(Notes 1)		ns
tWR	Read pulse width	400(Notes 2)		ns
tRC	Transfer waiting time after read	500(Notes 1)		ns
tCRPV	Waiting time before program verify	6		µs
tWP	Programming time		10	µs
tPC	Transfer waiting time after programming	500(Notes 1)		ns
tCREV	Waiting time before erase verify	6		ns
tWE	Erase time		9.5	ns
tEC	Transfer waiting time after erase	500(Notes 1)		ns
tc(CK)	SCLK input cycle time	250		ns
tw(CKH)	SCLK high-level pulse width	100		ns
tw(CKL)	SCLK low-level pulse width	100		ns
tr(CK)	SCLK rise time	20		ns
tf(CK)	SCLK fall time	20		ns
td(C-Q)	SDA output delay time	0	90	ns
th(C-Q)	SDA output hold time	0		ns
th(C-E)	SDA output hold time (only the 8th bit)	150(Notes 3)	250(Notes 4)	ns
tsu(D-C)	SDA input set up time	30		ns
th(C-D)	SDA input hold time	90		ns

Notes 1: When f(XIN) = 10 MHz or less, calculate the minimum value according to formula 1.

$$\text{Formula 1 : } \frac{5000}{f(XIN)} \times 10^6$$

2: When f(XIN) = 10 MHz or less, calculate the minimum value according to formula 2.

$$\text{Formula 2 : } \frac{4000}{f(XIN)} \times 10^6$$

3: When f(XIN) = 10 MHz or less, calculate the minimum value according to formula 3.

$$\text{Formula 3 : } \frac{1500}{f(XIN)} \times 10^6$$

4: When f(XIN) = 10 MHz or less, calculate the minimum value according to formula 4

$$\text{Formula 4 : } \frac{2500}{f(XIN)} \times 10^6$$

AC waveforms

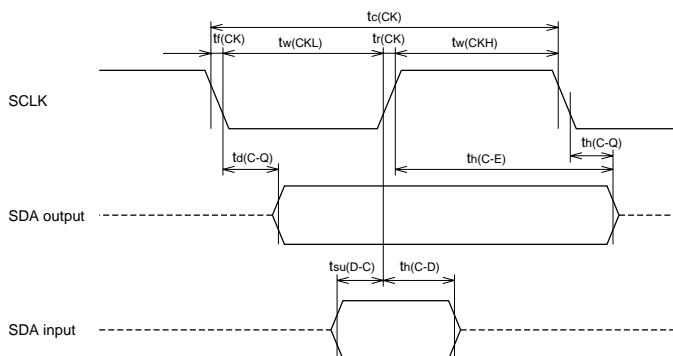

Test conditions for AC characteristics

- Output timing voltage : VOL = 0.8 V, VOH = 2.0 V
- Input timing voltage : VIL = 0.2 Vcc, VIH = 0.8 Vcc

(3) Flash memory mode 3 (CPU reprogramming mode)

The 3803/3804 group has the CPU reprogramming mode where a built-in flash memory is handled by the central processing unit (CPU).

In CPU reprogramming mode, the flash memory is handled by writing and reading to/from the flash memory control register (see Figure 99) and the flash command register (see Figure 100).

The CNVss pin is used as the VPP power supply pin in CPU reprogramming mode. It is necessary to apply the power-supply voltage of VPPH from the external to this pin.

Functional Outline (CPU reprogramming mode)

Figure 99 shows the structure of the flash memory control register.

Figure 100 shows the structure of the flash command register.

Bit 0 of the flash memory control register is the CPU reprogramming mode select bit. When this bit is set to "1" and VPPH is applied to the CNVss/VPP pin, the CPU reprogramming mode is selected. Whether the CPU reprogramming mode is realized or not is judged by reading the CPU reprogramming mode monitor flag (bit 2 of the flash memory control register).

Bit 1 is a busy flag which becomes "1" during erase and program execution.

Whether these operations have been completed or not is judged

by checking this flag after each command of erase and the program is executed.

Bits 4, 5 of the flash memory control register are the erase/program area select bits. These bits specify an area where erase and program is operated. When the erase command is executed after an area is specified by these bits, only the specified area is erased. Only for the specified area, programming is enabled; for the other areas, programming is disabled.

Figure 101 shows the structure of the CPU mode register in the CPU reprogramming mode. Set bit 1 to "0" (single-chip or memory expansion mode) in the CPU reprogramming mode.

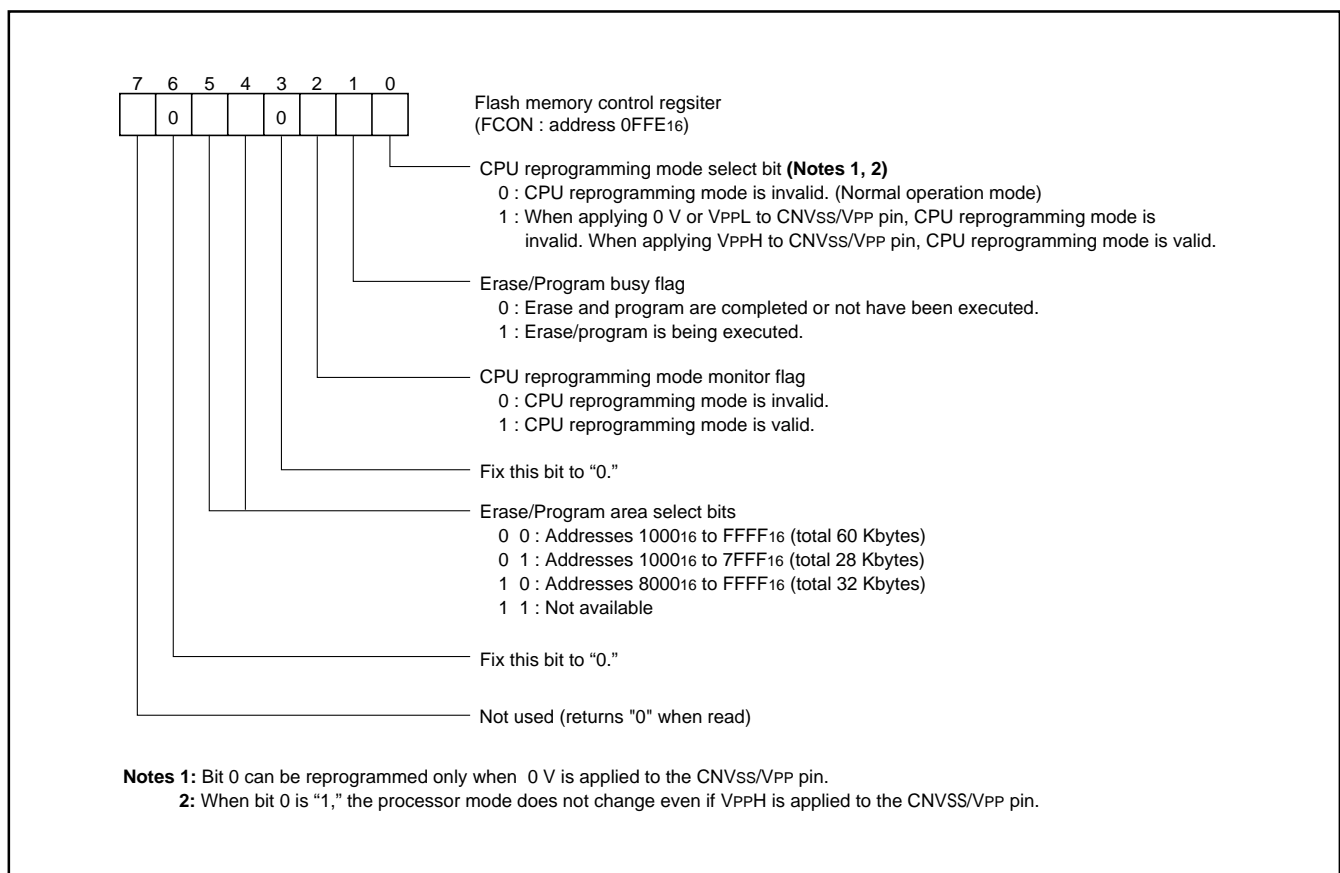

Fig. 99 Structure of flash memory control register

● CPU reprogramming mode operation procedure

The operation procedure in CPU reprogramming mode is described below.

< Beginning procedure >

- ① Apply 0 V to the CNVss/VPP pin for reset release.
- ② Set the CPU mode register (see Figure 101).
- ③ After CPU reprogramming mode control program is transferred to internal RAM, jump to this control program on RAM. (The following operations are controlled by this control program).
- √ Set "1" to the CPU reprogramming mode select bit.
- ⑤ Apply VPPH to the CNVss/VPP pin.
- ≈ Wait till CNVss/VPP pin becomes 12V.
- △ Read the CPU reprogramming mode monitor flag to confirm whether the CPU reprogramming mode is valid.
- ⑥ The operation of the flash memory is executed by software-command-writing to the flash command register .

Note: The following are necessary other than this:

- Control for data which is input from the external (serial I/O etc.) and to be programmed to the flash memory
- Initial setting for ports etc.
- Writing to the watchdog timer

< Release procedure >

- ① Apply 0 V to the CNVss/VPP pin.
- ② Wait till CNVss/VPP pin becomes 0 V.
- ③ Set the CPU reprogramming mode select bit to "0."

Each software command is explained as follows.

● Read command

When "0016" is written to the flash command register, the 3803/3804 group enters the read mode. The contents of the corresponding address can be read by reading the flash memory (For instance, with the LDA instruction etc.) under this condition.

The read mode is maintained until another command code is written to the flash command register. Accordingly, after setting the read mode once, the contents of the flash memory can continuously be read.

After reset and after the reset command is executed, the read mode is set.

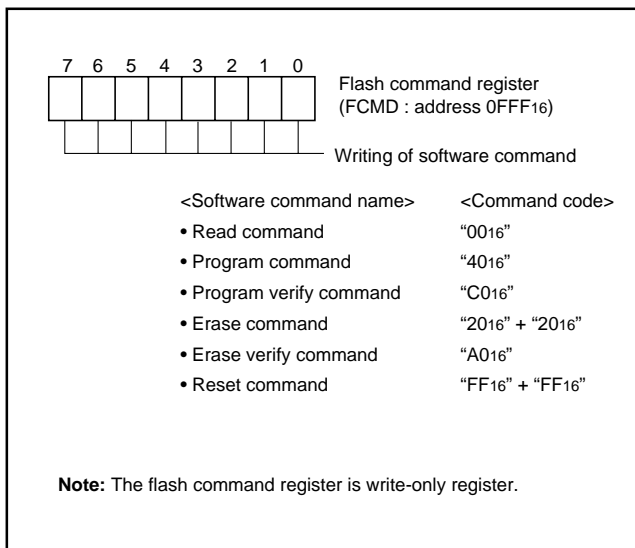

Fig. 100 Structure of flash command register

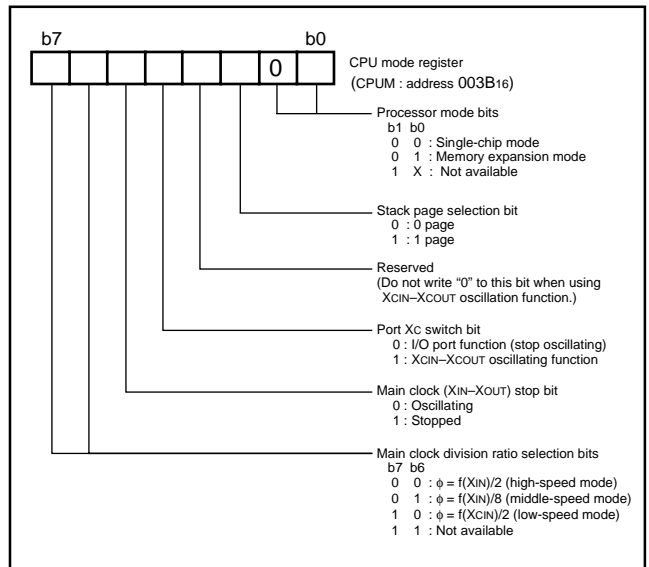

Fig. 101 Structure of CPU mode register in CPU rewriting mode

● Program command

When "40₁₆" is written to the flash command register, the 3803/3804 group enters the program mode.

Subsequently to this, if the instruction (for instance, STA or LDM instruction) for writing byte data in the address to be programmed is executed, the control circuit of the flash memory executes the program. The erase/program busy flag of the flash memory control register is set to "1" when the program starts, and becomes "0" when the program is completed. Accordingly, after the write instruction is executed, CPU can recognize the completion of the program by polling this bit.

The programmed area must be specified beforehand by the erase/program area select bits.

During programming, watchdog timer stops with "FFFF₁₆" set.

Note: A programming operation is not completed by executing the program command once. Always be sure to execute a program verify command after executing the program command. When the failure is found in this verification, the user must repeatedly execute the program command until the pass. Refer to Figure 102 for the flow chart of the programming.

● Program verify command

When "C0₁₆" is written to the flash command register, the 3803/3804 group enters the program verify mode. Subsequently to this, if the instruction (for instance, LDA instruction) for reading byte data from the address to be verified (i.e., previously programmed address), the contents which has been written to the address actually is read.

CPU compares this read data with data which has been written by the previous program command. In consequence of the comparison, if not agreeing, the operation of "program → program verify" must be executed again.

● Erase command

When writing "20₁₆" twice continuously to the flash command register, the flash memory control circuit performs erase to the area specified beforehand by the erase/program area select bits.

Erase/program busy flag of the flash memory control register becomes "1" when erase begins, and it becomes "0" when erase completes. Accordingly, CPU can recognize the completion of erase by polling this bit.

Data "00₁₆" must be written to all areas to be erased by the program and the program verify commands before the erase command is executed.

During erasing, watchdog timer stops with "FFFF₁₆" set.

Note: The erasing operation is not completed by executing the erase command once. Always be sure to execute an erase verify command after executing the erase command. When the failure is found in this verification, the user must repeatedly execute the erase command until the pass. Refer to Figure 102 for the erasing flowchart.

● Erase verify command

When "A0₁₆" is written to the flash command register, the 3803/3804 group enters the erase verify mode. Subsequently to this, if the instruction (for instance, LDA instruction) for reading byte data from the address to be verified, the contents of the address is read.

CPU must erase and verify to all erased areas in a unit of address.

If the address of which data is not "FF₁₆" (i.e., data is not erased) is found, it is necessary to discontinue erasure verification there, and execute the operation of "erase → erase verify" again.

Note: By executing the operation of "erase → erase verify" again when the memory not erased is found. It is unnecessary to write data "00₁₆" before erasing in this case.

● Reset command

The reset command is a command to discontinue the program or erase command on the way. When "FF₁₆" is written to the command register two times continuously after "40₁₆" or "20₁₆" is written to the flash command register, the program, or erase command becomes invalid (reset), and the 3803/3804 group enters the reset mode.

The contents of the memory does not change even if the reset command is executed.

DC Electric Characteristics

Note: The characteristic concerning the flash memory part are the same as the characteristic of the parallel I/O mode.

AC Electric Characteristics

Note: The characteristics are the same as the characteristic of the microcomputer mode.

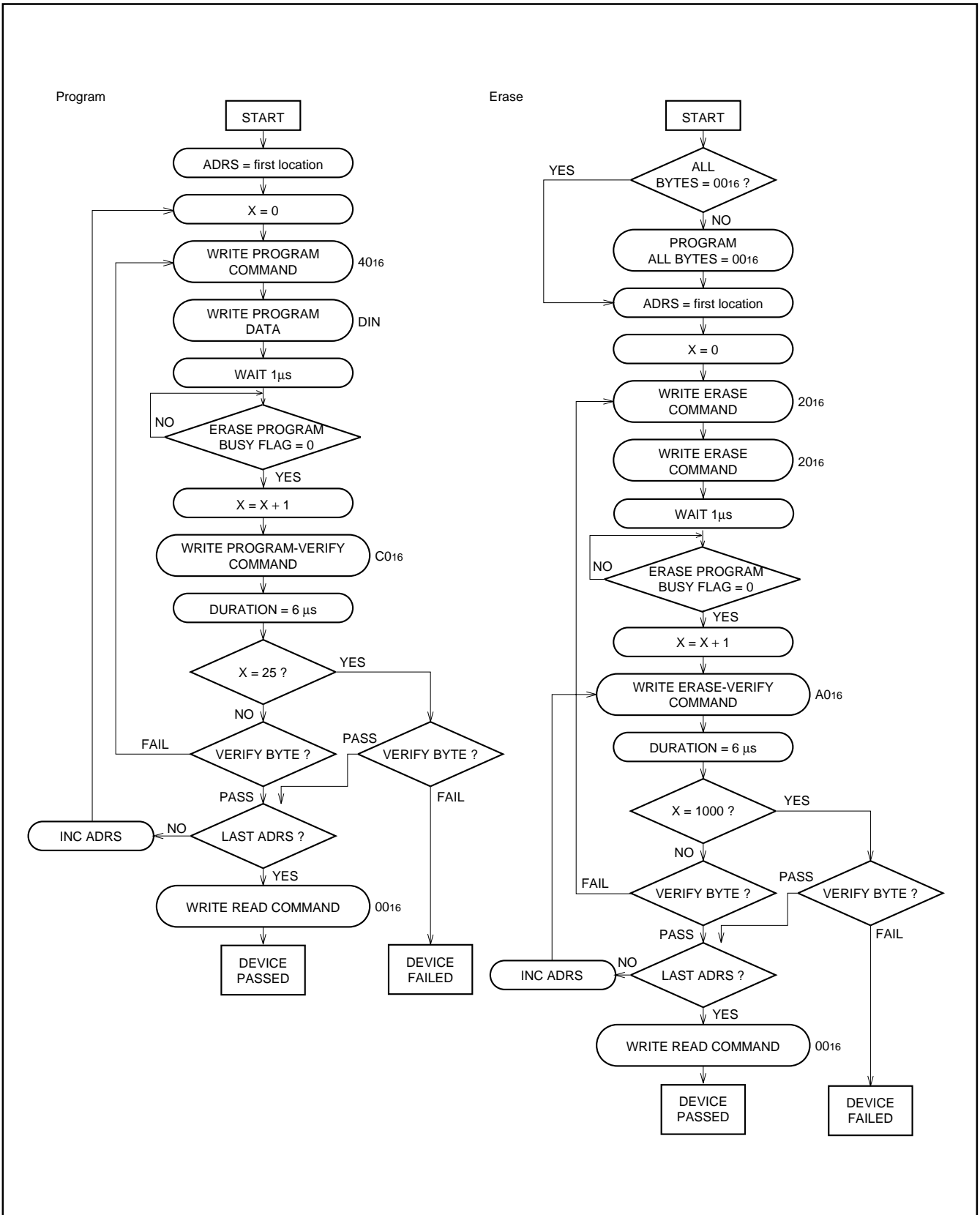

Fig. 102 Flowchart of program/erase operation at CPU reprogramming mode

NOTES ON PROGRAMMING

Processor Status Register

The contents of the processor status register (PS) after a reset are undefined, except for the interrupt disable flag (I) which is "1." After a reset, initialize flags which affect program execution. In particular, it is essential to initialize the index X mode (T) and the decimal mode (D) flags because of their effect on calculations.

Interrupts

The contents of the interrupt request bits do not change immediately after they have been written. After writing to an interrupt request register, execute at least one instruction before performing a BBC or BBS instruction.

Decimal Calculations

- To calculate in decimal notation, set the decimal mode flag (D) to "1", then execute an ADC or SBC instruction. After executing an ADC or SBC instruction, execute at least one instruction before executing a SEC, CLC, or CLD instruction.
- In decimal mode, the values of the negative (N), overflow (V), and zero (Z) flags are invalid.

Timers

If a value n (between 0 and 255) is written to a timer latch, the frequency division ratio is $1/(n+1)$.

Multiplication and Division Instructions

- The index X mode (T) and the decimal mode (D) flags do not affect the MUL and DIV instruction.
- The execution of these instructions does not change the contents of the processor status register.

Ports

The contents of the port direction registers cannot be read. The following cannot be used:

- The data transfer instruction (LDA, etc.)
- The operation instruction when the index X mode flag (T) is "1"
- The instruction with the addressing mode which uses the value of a direction register as an index
- The bit-test instruction (BBC or BBS, etc.) to a direction register
- The read-modify-write instructions (ROR, CLB, or SEB, etc.) to a direction register.

Use instructions such as LDM and STA, etc., to set the port direction registers.

Serial I/O

In clock synchronous serial I/O, if the receive side is using an external clock and it is to output the $\overline{\text{SRDY}}$ signal, set the transmit enable bit, the receive enable bit, and the $\overline{\text{SRDY}}$ output enable bit to "1."

Serial I/O continues to output the final bit from the TXD pin after transmission is completed. SOUT2 pin for serial I/O2 goes to high impedance after transfer is completed.

When in serial I/Os 1 and 3 (clock-synchronous mode) or in serial I/O2, an external clock is used as synchronous clock, write transmission data to the transmit buffer register or serial I/O2 register, during transfer clock is "H."

A-D Converter

The comparator uses capacitive coupling amplifier whose charge will be lost if the clock frequency is too low.

Therefore, make sure that $f(\text{XIN})$ is at least on 500 kHz during an A-D conversion.

Do not execute the STP or WIT instruction during an A-D conversion.

D-A Converter

The accuracy of the D-A converter becomes rapidly poor under the $V_{CC} = 4.0 \text{ V}$ or less condition; a supply voltage of $V_{CC} \geq 4.0 \text{ V}$ is recommended. When a D-A converter is not used, set all values of D-Ai conversion registers ($i=1, 2$) to "0016."

Instruction Execution Time

The instruction execution time is obtained by multiplying the period of the internal clock ϕ by the number of cycles needed to execute an instruction.

The number of cycles required to execute an instruction is shown in the list of machine instructions.

The period of the internal clock ϕ is half of the XIN period in high-speed mode.

NOTES ON USAGE

Handling of Power Source Pins

In order to avoid a latch-up occurrence, connect a capacitor suitable for high frequencies as bypass capacitor between power source pin (VCC pin) and GND pin (VSS pin), and between power source pin (VCC pin) and analog power source input pin (AVSS pin). Besides, connect the capacitor to as close as possible. For bypass capacitor which should not be located too far from the pins to be connected, a ceramic capacitor of 0.01 μ F–0.1 μ F is recommended.

Flash memory version

The CNVSS pin is connected to the internal memory circuit block by a low-ohmic resistance, since it has the multiplexed function to be a programmable power source pin (VPP pin) as well.

To improve the noise reduction, connect a track between CNVSS pin and VSS pin or VCC pin with 1 to 10 k Ω resistance.

The mask ROM version track of CNVSS pin has no operational interference even if it is connected to Vss pin or Vcc pin via a resistor.

DATA REQUIRED FOR MASK ORDERS

The following are necessary when ordering a mask ROM production:

- 1.Mask ROM Confirmation Form
- 2.Mark Specification Form
- 3.Data to be written to ROM, in EPROM form (three identical copies)

ELECTRICAL CHARACTERISTICS

Table 24 Absolute maximum ratings

Symbol	Parameter	Conditions	Ratings	Unit	
V _{CC}	Power source voltages		-0.3 to 6.5	V	
V _I	Input voltage P00-P07, P10-P17, P20-P27, P30, P31, P34-P37, P40-P47, P50-P57, P60-P67, VREF	All voltages are based on V _{SS} . Output transistors are cut off.	-0.3 to V _{CC} +0.3	V	
V _I	Input voltage P32, P33		-0.3 to 5.8	V	
V _I	Input voltage RESET, X _{IN}		-0.3 to V _{CC} +0.3	V	
V _I	Input voltage CNV _{SS} (Mask ROM version)		-0.3 to V _{CC} +0.3	V	
V _I	Input voltage CNV _{SS} (Flash memory version)		-0.3 to 13	V	
V _O	Output voltage P00-P07, P10-P17, P20-P27, P30, P31, P34-P37, P40-P47, P50-P57, P60-P67, X _{OUT}		-0.3 to V _{CC} +0.3	V	
V _O	Output voltage P32, P33		-0.3 to 5.8	V	
P _d	Power dissipation		T _a = 25 °C	1000 (Note)	mW
T _{opr}	Operating temperature			-20 to 85	°C
T _{stg}	Storage temperature			-65 to 125	°C

Note: In flat package, this value is 300 mV.

Table 25 Recommended operating conditions
(V_{CC} = 2.7 to 5.5 V, T_a = -20 to 85 °C, unless otherwise noted)

Symbol	Parameter	Limits			Unit
		Min.	Typ.	Max.	
VCC	Power source voltage (f(X _{IN}) ≤ 8.4 MHz)	2.7	5.0	5.5	V
	Power source voltage (f(X _{IN}) ≤ 12.5 MHz)	4.0	5.0	5.5	
	Power source voltage (f(X _{IN}) ≤ 16.8 MHz)	4.5	5.0	5.5	
VCC	Power source voltage (flash memory version)	4.0	5.0	5.5	V
VSS	Power source voltage		0		V
VREF	Analog reference voltage (when A-D converter is used)	2.0		V _{CC}	V
	Analog reference voltage (when D-A converter is used)	2.7		V _{CC}	V
AVSS	Analog power source voltage		0		V
VIA	Analog input voltage AN ₀ -AN ₁₅	AVSS		V _{CC}	V
V _{IH}	"H" input voltage P ₀₀ -P ₀₇ , P ₁₀ -P ₁₇ , P ₂₀ -P ₂₇ , P ₃₀ , P ₃₃ , P ₃₄ -P ₃₇ , P ₄₀ -P ₄₇ , P ₅₀ -P ₅₇ , P ₆₀ -P ₆₇	0.8V _{CC}		V _{CC}	V
V _{IH}	"H" input voltage P ₃₂ , P ₃₃	0.8V _{CC}		5.5	V
V _{IH}	"H" input voltage (when I ² C-BUS input level is selected) SDA, SCL	0.7V _{CC}		5.5	V
V _{IH}	"H" input voltage (when SMBUS input level is selected) SDA, SCL	1.4		5.5	V
V _{IH}	"H" input voltage RESET, X _{IN} , X _{CIN} , CNVSS	0.8V _{CC}		V _{CC}	V
V _{IL}	"L" input voltage P ₀₀ -P ₀₇ , P ₁₀ -P ₁₇ , P ₂₀ -P ₂₇ , P ₃₀ -P ₃₇ , P ₄₀ -P ₄₇ , P ₅₀ -P ₅₇ , P ₆₀ -P ₆₇	0		0.2V _{CC}	V
V _{IL}	"L" input voltage (when I ² C-BUS input level is selected) SDA, SCL	0		0.3V _{CC}	V
V _{IL}	"L" input voltage (when SMBUS input level is selected) SDA, SCL	0		0.6	V
V _{IL}	"L" input voltage RESET, CNVSS			0.2V _{CC}	V
V _{IL}	"L" input voltage X _{IN} , X _{CIN}			0.16V _{CC}	V

Table 26 Recommended operating conditions
(V_{CC} = 2.7 to 5.5 V, T_a = -20 to 85 °C, unless otherwise noted)

Symbol	Parameter		Limits			Unit
			Min.	Typ.	Max.	
ΣIOH(peak)	"H" total peak output current	P00-P07, P10-P17, P20-P27, P30, P31, P34-P37 (Note 1)			-80	mA
ΣIOH(peak)	"H" total peak output current	P40-P47, P50-P57, P60-P67 (Note 1)			-80	mA
ΣIOL(peak)	"L" total peak output current	P00-P07, P10-P17, P30-P37 (Note 1)			80	mA
ΣIOL(peak)	"L" total peak output current	P20-P27 (Note 1)			80	mA
ΣIOL(peak)	"L" total peak output current	P40-P47, P50-P57, P60-P67 (Note 1)			80	mA
ΣIOH(avg)	"H" total average output current	P00-P07, P10-P17, P20-P27, P30, P31, P34-P37 (Note 1)			-40	mA
ΣIOH(avg)	"H" total average output current	P40-P47, P50-P57, P60-P67 (Note 1)			-40	mA
ΣIOL(avg)	"L" total average output current	P00-P07, P10-P17, P30-P37 (Note 1)			40	mA
ΣIOL(avg)	"L" total average output current	P20-P27 (Note 1)			40	mA
ΣIOL(avg)	"L" total average output current	P40-P47, P50-P57, P60-P67 (Note 1)			40	mA
IOH(peak)	"H" peak output current	P00-P07, P10-P17, P20-P27, P30, P31, P34-P37, P40-P47, P50-P57, P60-P67 (Note 2)			-10	mA
IOL(peak)	"L" peak output current	P00-P07, P10-P17, P30-P37, P40-P47, P50-P57, P60-P67 (Note 2)			10	mA
IOL(peak)	"L" peak output current	P20-P27 (Note 2)			20	mA
IOH(avg)	"H" average output current	P00-P07, P10-P17, P20-P27, P30, P31, P34-P37, P40-P47, P50-P57, P60-P67 (Note 3)			-5	mA
IOL(avg)	"L" average output current	P00-P07, P10-P17, P30-P37, P40-P47, P50-P57, P60-P67 (Note 3)			5	mA
IOL(avg)	"L" average output current	P20-P27 (Note 3)			10	mA
f(XIN)	Main clock input oscillation frequency (Note 4)	V _{CC} = 4.5-5.5 V			16.8	MHz
		V _{CC} = 4.0-4.5 V			8.6V _{CC} -21.9	MHz
		V _{CC} = 2.7-4.0 V			$\frac{41}{13}V_{CC}-\frac{3}{26}$	MHz
f(XCIN)	Sub-clock input oscillation frequency (Notes 4, 5)		32.768	50		kHz

Notes 1: The total output current is the sum of all the currents flowing through all the applicable ports. The total average current is an average value measured over 100 ms. The total peak current is the peak value of all the currents.

2: The peak output current is the peak current flowing in each port.

3: The average output current IOL(avg), IOH(avg) are average value measured over 100 ms.

4: When the oscillation frequency has a duty cycle of 50%.

5: When using the microcomputer in low-speed mode, set the sub-clock input oscillation frequency on condition that f(XCIN) < f(XIN)/3.

Table 27 Electrical characteristics

(VCC = 2.7 to 5.5 V, VSS = 0 V, Ta = -20 to 85 °C, unless otherwise noted)

Symbol	Parameter	Test conditions	Limits			Unit
			Min.	Typ.	Max.	
VOH	"H" output voltage P00-P07, P10-P17, P20-P27 P30, P31, P34-P37, P40-P47, P50-P57, P60-P67 (Note 1)	IOH = -10 mA VCC = 4.0-5.5 V	VCC-2.0			V
		IOH = -1.0 mA VCC = 2.7-5.5 V	VCC-1.0			V
VOL	"L" output voltage P00-P07, P10-P17, P20-P27 P30-P37, P40-P47, P50-P57 P60-P67	IOI = 10 mA VCC = 4.0-5.5 V			2.0	V
		IOI = 1.6 mA VCC = 2.7-5.5 V			0.4	V
VT+~VT-	Hysteresis CNTR0, CNTR1, CNTR2, INT0-INT4			0.4		V
VT+~VT-	Hysteresis RXD1, SCLK1, SIN2, SCLK2, RXD3, SCLK3			0.5		V
VT+~VT-	Hysteresis $\overline{\text{RESET}}$			0.5		V
IiH	"H" input current P00-P07, P10-P17, P20-P27 P30-P37, P40-P47, P50-P57 P60-P67	Vi = VCC (Pin floating. Pull-up transistors "off")			5.0	μA
IiH	"H" input current $\overline{\text{RESET}}$, CNVSS	Vi = VCC			5.0	μA
IiH	"H" input current XIN	Vi = VCC		4		μA
IiL	"L" input current P00-P07, P10-P17, P20-P27, P30-P37, P40-P47, P50-P57, P60-P67	Vi = VSS (Pin floating. Pull-up transistors "off")			-5.0	μA
IiL	"L" input current $\overline{\text{RESET}}$, CNVSS	Vi = VSS			-5.0	μA
IiL	"L" input current XIN	Vi = VSS		-4		μA
IiL	"L" input current (at Pull-up) P00-P07, P10-P17, P20-P27, P30, P31, P34-P37, P40-P47, P50-P57, P60-P67	Vi = VSS VCC = 5.0 V	-80	-210	-420	μA
		Vi = VSS VCC = 3.0 V	-30	-70	-140	μA
VRAM	RAM hold voltage	When clock stopped	2.0		5.5	V

Note 1: P35 is measured when the P35/TxD3 P-channel output disable bit of the UART3 control register (bit 4 of address 003316) is "0".
P45 is measured when the P45/TxD1 P-channel output disable bit of the UART1 control register (bit 4 of address 001B16) is "0".

Table 28 Electrical characteristics (flash memory version)
 (V_{CC} = 2.7 to 5.5 V, V_{SS} = 0 V, T_a = -20 to 85 °C, unless otherwise noted)

Symbol	Parameter	Test conditions	Limits			Unit	
			Min.	Typ.	Max.		
I _{CC}	Power source current	High-speed mode f(X _{IN}) = 16.8 MHz f(XC _{IN}) = 32.768 kHz Output transistors "off"		12	22	mA	
		High-speed mode f(X _{IN}) = 12.5 MHz f(XC _{IN}) = 32.768 kHz Output transistors "off"		10	18	mA	
		High-speed mode f(X _{IN}) = 8.4 MHz f(XC _{IN}) = 32.768 kHz Output transistors "off"		7	13.5	mA	
		High-speed mode f(X _{IN}) = 16.8 MHz (in WIT state) f(XC _{IN}) = 32.768 kHz Output transistors "off"		3.5	6	mA	
		Low-speed mode f(X _{IN}) = stopped f(XC _{IN}) = 32.768 kHz Output transistors "off"		60	200	μA	
		Low-speed mode f(X _{IN}) = stopped f(XC _{IN}) = 32.768 kHz (in WIT state) Output transistors "off"		30	60	μA	
		Low-speed mode (V _{CC} = 3 V) f(X _{IN}) = stopped f(XC _{IN}) = 32.768 kHz Output transistors "off"		20	55	μA	
		Low-speed mode (V _{CC} = 3 V) f(X _{IN}) = stopped f(XC _{IN}) = 32.768 kHz (in WIT state) Output transistors "off"		8.0	20.0	μA	
		Middle-speed mode f(X _{IN}) = 16.8 MHz f(XC _{IN}) = stopped Output transistors "off"		6	12	mA	
		Middle-speed mode f(X _{IN}) = 16.8 MHz (in WIT state) f(XC _{IN}) = stopped Output transistors "off"		3	5.5	mA	
		Increment when A-D conversion is executed f(X _{IN}) = 16.8 MHz		500		μA	
		All oscillation stopped (in STP state) Output transistors "off"	T _a = 25 °C		0.1	1.0	μA
			T _a = 85 °C			10	μA

Table 29 Electrical characteristics (mask ROM version)
 (VCC = 2.7 to 5.5 V, VSS = 0 V, Ta = -20 to 85 °C, unless otherwise noted)

Symbol	Parameter	Test conditions	Limits			Unit	
			Min.	Typ.	Max.		
ICC	Power source current	High-speed mode f(XIN) = 16.8 MHz f(XCIN) = 32.768 kHz Output transistors "off"		8	15	mA	
		High-speed mode f(XIN) = 12.5 MHz f(XCIN) = 32.768 kHz Output transistors "off"		6.5	12	mA	
		High-speed mode f(XIN) = 8.4 MHz f(XCIN) = 32.768 kHz Output transistors "off"		5	9	mA	
		High-speed mode f(XIN) = 16.8 MHz (in WIT state) f(XCIN) = 32.768 kHz Output transistors "off"		2	3.6	mA	
		Low-speed mode f(XIN) = stopped f(XCIN) = 32.768 kHz Output transistors "off"		55	200	μA	
		Low-speed mode f(XIN) = stopped f(XCIN) = 32.768 kHz (in WIT state) Output transistors "off"		40	70	μA	
		Low-speed mode (VCC = 3 V) f(XIN) = stopped f(XCIN) = 32.768 kHz Output transistors "off"		15	40	μA	
		Low-speed mode (VCC = 3 V) f(XIN) = stopped f(XCIN) = 32.768 kHz (in WIT state) Output transistors "off"		8	15	μA	
		Middle-speed mode f(XIN) = 16.8 MHz f(XCIN) = stopped Output transistors "off"		4	7	mA	
		Middle-speed mode f(XIN) = 16.8 MHz (in WIT state) f(XCIN) = stopped Output transistors "off"		1.8	3.3	mA	
		Increment when A-D conversion is executed f(XIN) = 16.8 MHz		500		μA	
		All oscillation stopped (in STP state) Output transistors "off"	Ta = 25 °C		0.1	1.0	μA
			Ta = 85 °C			10	μA

Table 30 A-D converter characteristics (1)

(VCC = 2.7 to 5.5 V, VREF = 2.0 V to VCC, VSS = AVSS = 0 V, Ta = -20 to 85 °C, unless otherwise noted)

10-bit A-D mode (when conversion mode selection bit (bit 7 of address 003816) is "0")

Symbol	Parameter		Test conditions	Limits			Unit
				Min.	Typ.	Max.	
-	Resolution					10	bit
-	Absolute accuracy (excluding quantization error)		VCC = VREF = 5.0 V			±4	LSB
tCONV	Conversion time					61	2tc(XIN)
RLADDER	Ladder resistor			12	35	100	kΩ
IVREF	Reference power source input current	at A-D converter operated	VREF = 5.0 V	50	150	200	μA
		at A-D converter stopped	VREF = 5.0 V			5	μA
II(AD)	A-D port input current					5.0	μA

Table 31 A-D converter characteristics (2)

(VCC = 2.7 to 5.5 V, VREF = 2.0 V to VCC, VSS = AVSS = 0 V, Ta = -20 to 85 °C, unless otherwise noted)

8-bit A-D mode (when conversion mode selection bit (bit 7 of address 003816) is "1")

Symbol	Parameter		Test conditions	Limits			Unit
				Min.	Typ.	Max.	
-	Resolution					8	bit
-	Absolute accuracy (excluding quantization error)		VCC = VREF = 5.0 V			±2	LSB
tCONV	Conversion time					50	2tc(XIN)
RLADDER	Ladder resistor			12	35	100	kΩ
IVREF	Reference power source input current	at A-D converter operated	VREF = 5.0 V	50	150	200	μA
		at A-D converter stopped	VREF = 5.0 V			5	μA
II(AD)	A-D port input current					5.0	μA

Table 32 D-A converter characteristics

(VCC = 2.7 to 5.5 V, VREF = 2.7 V to VCC, VSS = AVSS = 0 V, Ta = -20 to 85 °C, unless otherwise noted)

Symbol	Parameter		Test conditions	Limits			Unit
				Min.	Typ.	Max.	
-	Resolution					8	Bits
-	Absolute accuracy	VCC = 4.0-5.5 V				1.0	%
		VCC = 2.7-4.0 V				2.5	%
tsu	Setting time					3	μs
RO	Output resistor			1	2.5	4	kΩ
IVREF	Reference power source input current (Note 1)					3.2	mA

Note 1: Using one D-A converter, with the value in the D-A conversion register of the other D-A converter being "0016".

TIMING REQUIREMENTS

Table 33 Timing requirements (1)

(V_{CC} = 4.0 to 5.5 V, V_{SS} = 0 V, T_a = -20 to 85 °C, unless otherwise noted)

Symbol	Parameter	Limits			Unit
		Min.	Typ.	Max.	
tw(RESET)	Reset input "L" pulse width	2			μs
tc(XIN)	Main clock input cycle time (V _{CC} = 4.5–5.5 V)	59.5			ns
	Main clock input cycle time (V _{CC} = 4.0–4.5 V)	$\frac{10000}{86V_{CC}-219}$			ns
tWH(XIN)	Main clock input "H" pulse width (V _{CC} = 4.5–5.5 V)	25			ns
	Main clock input "H" pulse width (V _{CC} = 4.0–4.5 V)	$\frac{4000}{86V_{CC}-219}$			ns
tWL(XIN)	Main clock input "L" pulse width (V _{CC} = 4.5–5.5 V)	25			ns
	Main clock input "L" pulse width (V _{CC} = 4.0–4.5 V)	$\frac{4000}{86V_{CC}-219}$			ns
tc(XCIN)	Sub-clock input cycle time	20			μs
tWH(XCIN)	Sub-clock input "H" pulse width	5			μs
tWL(XCIN)	Sub-clock input "L" pulse width	5			μs
tc(CNTR)	CNTR0–CNTR2 input cycle time	200			ns
tWH(CNTR)	CNTR0–CNTR2 input "H" pulse width	80			ns
tWL(CNTR)	CNTR0–CNTR2 input "L" pulse width	80			ns
tWH(INT)	INT00, INT01, INT1, INT2, INT3, INT40, INT41 input "H" pulse width	80			ns
tWL(INT)	INT00, INT01, INT1, INT2, INT3, INT40, INT41 input "L" pulse width	80			ns
tc(SCLK1), tc(SCLK3)	Serial I/O1, serial I/O3 clock input cycle time (Note)	800			ns
tWH(SCLK1), tWH(SCLK3)	Serial I/O1, serial I/O3 clock input "H" pulse width (Note)	370			ns
tWL(SCLK1), tWL(SCLK3)	Serial I/O1, serial I/O3 clock input "L" pulse width (Note)	370			ns
tsu(RxD1-SCLK1), tsu(RxD3-SCLK3)	Serial I/O1, serial I/O3 input setup time	220			ns
th(SCLK1-RxD1), th(SCLK1-RxD3)	Serial I/O1, serial I/O3 input hold time	100			ns
tc(SCLK2)	Serial I/O2 clock input cycle time	1000			ns
tWH(SCLK2)	Serial I/O2 clock input "H" pulse width	400			ns
tWL(SCLK2)	Serial I/O2 clock input "L" pulse width	400			ns
tsu(SIN2-SCLK2)	Serial I/O2 input setup time	200			ns
th(SCLK2-SIN2)	Serial I/O2 input hold time	200			ns

Note : When bit 6 of address 001A16 is "1" (clock synchronous).

Divide this value by four when bit 6 of address 001A16 and bit 6 of address 003216 are "0" (UART).

Table 34 Timing requirements (2)

(V_{CC} = 2.7 to 4.0 V, V_{SS} = 0 V, T_a = -20 to 85 °C, unless otherwise noted)

Symbol	Parameter	Limits			Unit
		Min.	Typ.	Max.	
tw(RESET)	Reset input "L" pulse width	2			μs
tc(XIN)	Main clock input cycle time	$\frac{26 \times 10^3}{82V_{CC}-3}$			ns
twh(XIN)	Main clock input "H" pulse width	$\frac{10000}{82V_{CC}-3}$			ns
twl(XIN)	Main clock input "L" pulse width	$\frac{10000}{82V_{CC}-3}$			ns
tc(XCIN)	Sub-clock input cycle time	20			μs
twh(XCIN)	Sub-clock input "H" pulse width	5			μs
twl(XCIN)	Sub-clock input "L" pulse width	5			μs
tc(CNTR)	CNTR0–CNTR2 input cycle time	500			ns
twh(CNTR)	CNTR0–CNTR2 input "H" pulse width	230			ns
twl(CNTR)	CNTR0–CNTR2 input "L" pulse width	230			ns
twh(INT)	INT00, INT01, INT1, INT2, INT3, INT40, INT41 input "H" pulse width	230			ns
twl(INT)	INT00, INT01, INT1, INT2, INT3, INT40, INT41 input "L" pulse width	230			ns
tc(SCLK1), tc(SCLK3)	Serial I/O1, serial I/O3 clock input cycle time (Note)	2000			ns
twh(SCLK1), twh(SCLK3)	Serial I/O1, serial I/O3 clock input "H" pulse width (Note)	950			ns
twl(SCLK1), twl(SCLK3)	Serial I/O1, serial I/O3 clock input "L" pulse width (Note)	950			ns
tsu(RxD1-SCLK1), tsu(RxD3-SCLK3)	Serial I/O1, serial I/O3 input setup time	400			ns
th(SCLK1-RxD1), th(SCLK1-RxD3)	Serial I/O1, serial I/O3 input hold time	200			ns
tc(SCLK2)	Serial I/O2 clock input cycle time	2000			ns
twh(SCLK2)	Serial I/O2 clock input "H" pulse width	950			ns
twl(SCLK2)	Serial I/O2 clock input "L" pulse width	950			ns
tsu(SIN2-SCLK2)	Serial I/O2 input setup time	400			ns
th(SCLK2-SIN2)	Serial I/O2 input hold time	300			ns

Note : When bit 6 of address 001A16 is "1" (clock synchronous).

Divide this value by four when bit 6 of address 001A16 is "0" (UART).

Table 35 Switching characteristics 1

(V_{CC} = 4.0 to 5.5 V, V_{SS} = 0 V, T_a = -20 to 85 °C, unless otherwise noted)

Symbol	Parameter	Test conditions	Limits			Unit
			Min.	Typ.	Max.	
t _{WH} (SCLK1), t _{WH} (SCLK3)	Serial I/O1, serial I/O3 clock output "H" pulse width	Fig. 65	tc(SCLK1)/2-30			ns
t _{WL} (SCLK1), t _{WL} (SCLK3)	Serial I/O1, serial I/O3 clock output "L" pulse width		tc(SCLK1)/2-30			ns
t _d (SCLK1-TxD1) , t _d (SCLK3-TxD3)	Serial I/O1, serial I/O3 output delay time (Note 1)				140	ns
t _v (SCLK1-TxD1) , t _v (SCLK3-TxD3)	Serial I/O1, serial I/O3 output valid time (Note 1)		-30			ns
t _r (SCLK1) , t _r (SCLK3)	Serial I/O1, serial I/O3 clock output rising time				30	ns
t _f (SCLK1), t _f (SCLK3)	Serial I/O1, serial I/O3 clock output falling time				30	ns
t _{WH} (SCLK2)	Serial I/O2 clock output "H" pulse width		tc(SCLK2)/2-160			ns
t _{WL} (SCLK2)	Serial I/O2 clock output "L" pulse width		tc(SCLK2)/2-160			ns
t _d (SCLK2-SOUT2)	Serial I/O2 output delay time				200	ns
t _v (SCLK2-SOUT2)	Serial I/O2 output valid time		0			ns
t _f (SCLK2)	Serial I/O2 clock output falling time				30	ns
t _r (CMOS)	CMOS output rising time (Note 2)			10	30	ns
t _f (CMOS)	CMOS output falling time (Note 2)			10	30	ns

Notes 1: When the P45/TxD1 P-channel output disable bit of the UART1 control register (bit 4 of address 001B16) is "0".
When the P35/TxD3 P-channel output disable bit of the UART3 control register (bit 4 of address 003316) is "0".

2: The XOUT pin is excluded.

Table 36 Switching characteristics 2

(V_{CC} = 2.7 to 4.0 V, V_{SS} = 0 V, T_a = -20 to 85 °C, unless otherwise noted)

Symbol	Parameter	Test conditions	Limits			Unit
			Min.	Typ.	Max.	
t _{WH} (SCLK1), t _{WH} (SCLK3)	Serial I/O1, serial I/O3 clock output "H" pulse width	Fig. 65	tc(SCLK1)/2-50			ns
t _{WL} (SCLK1), t _{WL} (SCLK3)	Serial I/O1, serial I/O3 clock output "L" pulse width		tc(SCLK1)/2-50			ns
t _d (SCLK1-TxD1) , t _d (SCLK3-TxD3)	Serial I/O1, serial I/O3 output delay time (Note 1)				350	ns
t _v (SCLK1-TxD1) , t _v (SCLK3-TxD3)	Serial I/O1, serial I/O3 output valid time (Note 1)		-30			ns
t _r (SCLK1) , t _r (SCLK3)	Serial I/O1, serial I/O3 clock output rising time				50	ns
t _f (SCLK1), t _f (SCLK3)	Serial I/O1, serial I/O3 clock output falling time				50	ns
t _{WH} (SCLK2)	Serial I/O2 clock output "H" pulse width		tc(SCLK2)/2-240			ns
t _{WL} (SCLK2)	Serial I/O2 clock output "L" pulse width		tc(SCLK2)/2-240			ns
t _d (SCLK2-SOUT2)	Serial I/O2 output delay time				400	ns
t _v (SCLK2-SOUT2)	Serial I/O2 output valid time		0			ns
t _f (SCLK2)	Serial I/O2 clock output falling time				50	ns
t _r (CMOS)	CMOS output rising time (Note 2)			20	50	ns
t _f (CMOS)	CMOS output falling time (Note 2)			20	50	ns

Notes 1: When the P45/TxD1 P-channel output disable bit of the UART1 control register (bit 4 of address 001B16) is "0".
When the P35/TxD3 P-channel output disable bit of the UART3 control register (bit 4 of address 003316) is "0".

2: The XOUT pin is excluded.

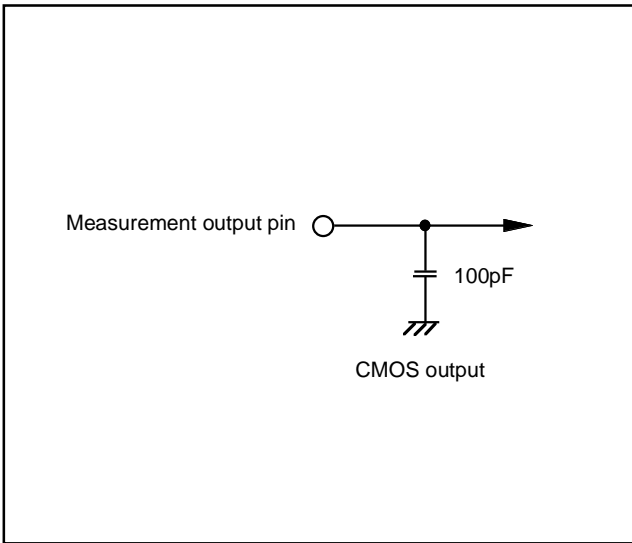

Fig. 103 Circuit for measuring output switching characteristics (1)

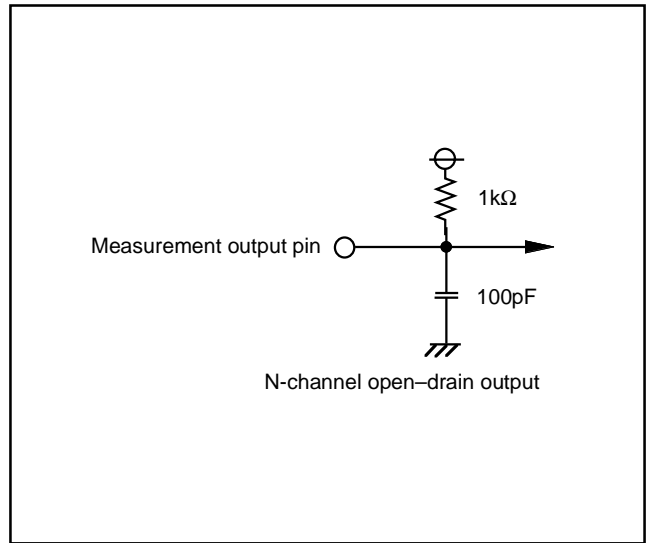

Fig. 104 Circuit for measuring output switching characteristics (2)

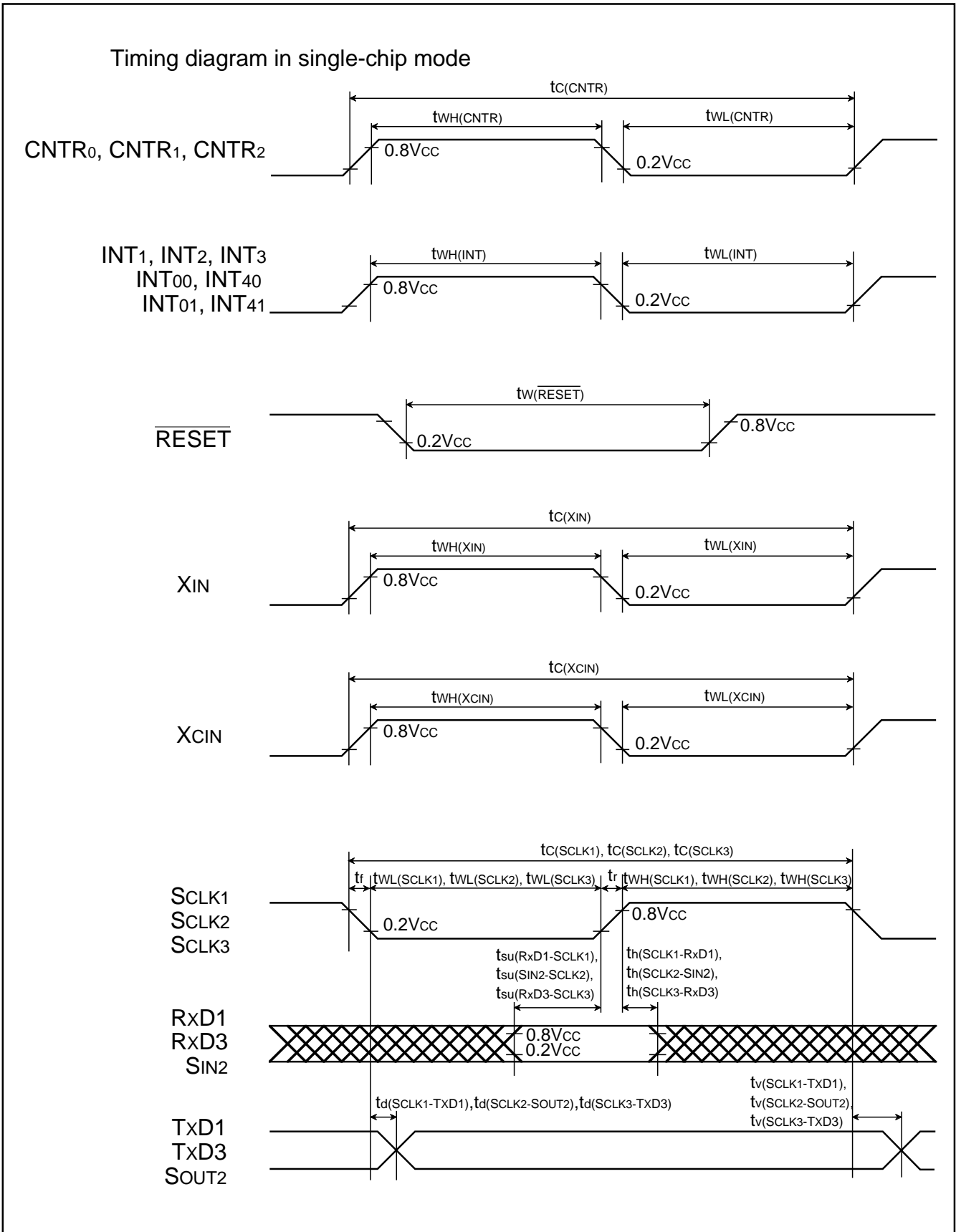

Fig. 105 Timing diagram (in single-chip mode)

Table 37 Multi-master I²C-BUS bus line characteristics

Symbol	Parameter	Standard clock mode		High-speed clock mode		Unit
		Min.	Max.	Min.	Max.	
t _{BUF}	Bus free time	4.7		1.3		μs
t _{HD:STA}	Hold time for START condition	4.0		0.6		μs
t _{LOW}	Hold time for SCL clock = "0"	4.7		1.3		μs
t _R	Rising time of both SCL and SDA signals		1000	20+0.1C _b	300	ns
t _{HD:DAT}	Data hold time	0		0	0.9	μs
t _{HIGH}	Hold time for SCL clock = "1"	4.0		0.6		μs
t _F	Falling time of both SCL and SDA signals		300	20+0.1C _b	300	ns
t _{SU:DAT}	Data setup time	250		100		ns
t _{SU:STA}	Setup time for repeated START condition	4.7		0.6		μs
t _{SU:STO}	Setup time for STOP condition	4.0		0.6		μs

Note: C_b = total capacitance of 1 bus line

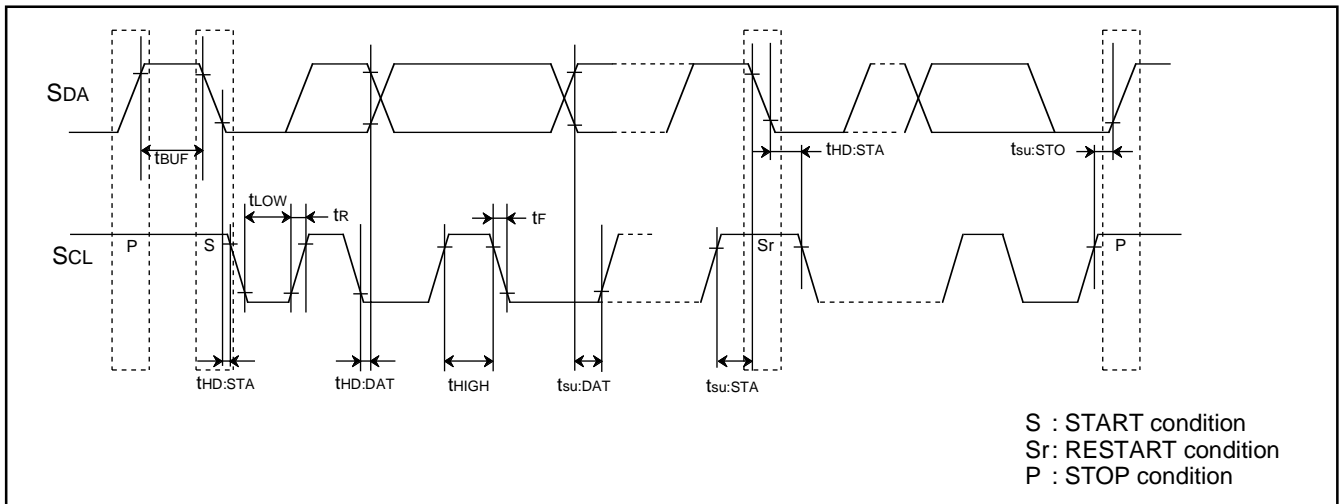
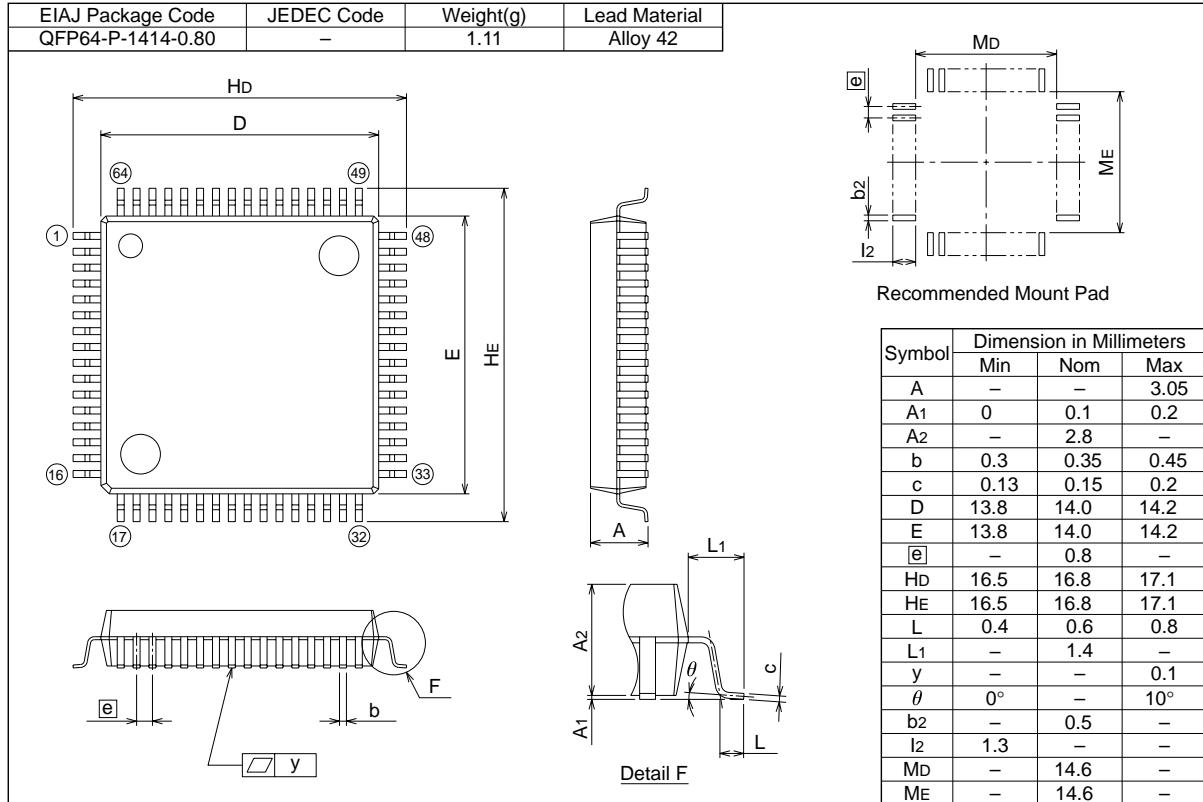

Fig. 106 Timing diagram of multi-master I²C-BUS

PACKAGE OUTLINE

64P6N-A

Plastic 64pin 14X14mm body QFP



64P4B

Plastic 64pin 750mil SDIP

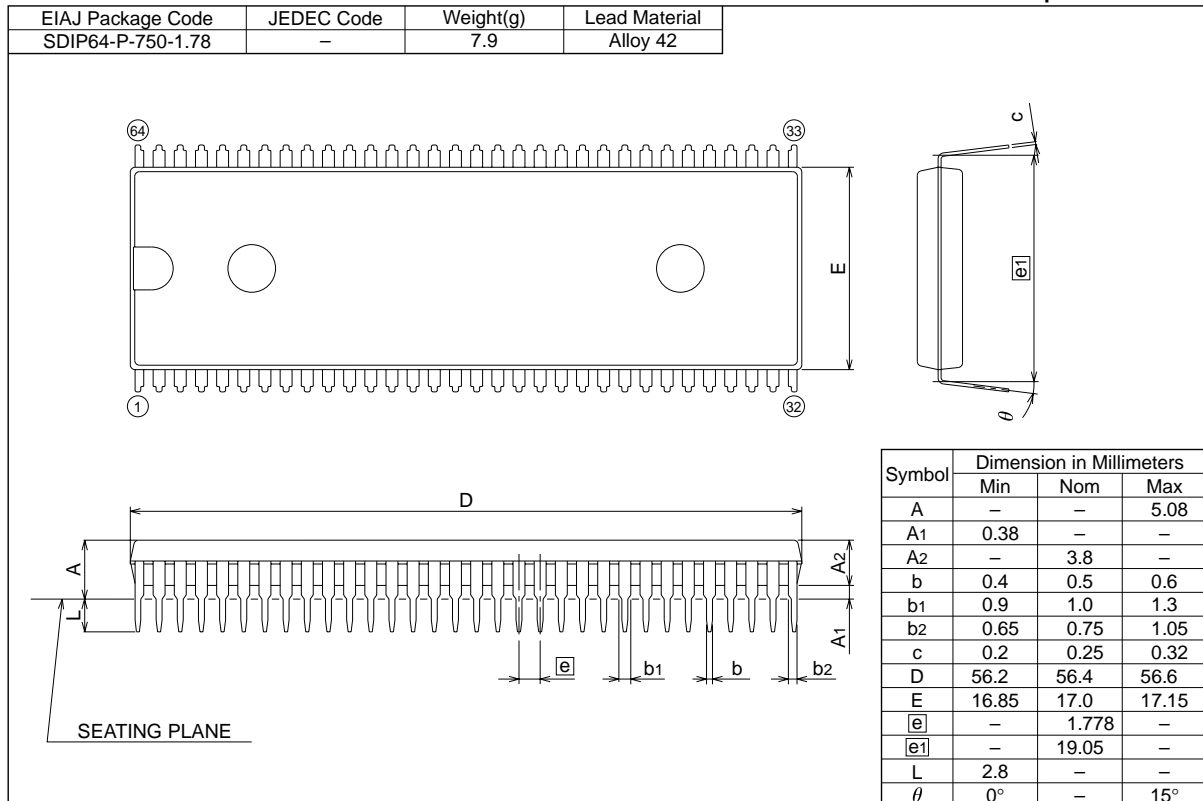

64P6Q-A

Plastic 64pin 10X10mm body LQFP

EIAJ Package Code	JEDEC Code	Weight(g)	Lead Material
LQFP64-P-1010-0.50	-	-	Cu Alloy

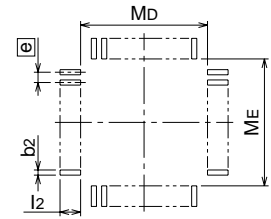
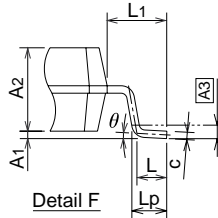
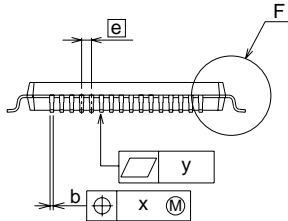
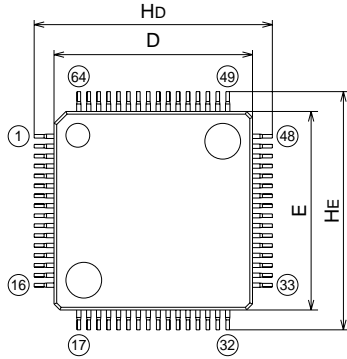

Recommended Mount Pad

Symbol	Dimension in Millimeters		
	Min	Nom	Max
A	-	-	1.7
A1	0	0.1	0.2
A2	-	1.4	-
b	0.13	0.18	0.28
c	0.105	0.125	0.175
D	9.9	10.0	10.1
E	9.9	10.0	10.1
e	-	0.5	-
Hd	11.8	12.0	12.2
HE	11.8	12.0	12.2
L	0.3	0.5	0.7
L1	-	1.0	-
Lp	0.45	0.6	0.75
A3	-	0.25	-
x	-	-	0.08
y	-	-	0.1
θ	0°	-	10°
b2	-	0.225	-
l2	1.0	-	-
Md	-	10.4	-
ME	-	10.4	-

Keep safety first in your circuit designs!

- Mitsubishi Electric Corporation puts the maximum effort into making semiconductor products better and more reliable, but there is always the possibility that trouble may occur with them. Trouble with semiconductors may lead to personal injury, fire or property damage. Remember to give due consideration to safety when making your circuit designs, with appropriate measures such as (i) placement of substitutive, auxiliary circuits, (ii) use of non-flammable material or (iii) prevention against any malfunction or mishap.

Notes regarding these materials

- These materials are intended as a reference to assist our customers in the selection of the Mitsubishi semiconductor product best suited to the customer's application; they do not convey any license under any intellectual property rights, or any other rights, belonging to Mitsubishi Electric Corporation or a third party.
- Mitsubishi Electric Corporation assumes no responsibility for any damage, or infringement of any third-party's rights, originating in the use of any product data, diagrams, charts or circuit application examples contained in these materials.
- All information contained in these materials, including product data, diagrams and charts, represent information on products at the time of publication of these materials, and are subject to change by Mitsubishi Electric Corporation without notice due to product improvements or other reasons. It is therefore recommended that customers contact Mitsubishi Electric Corporation or an authorized Mitsubishi Semiconductor product distributor for the latest product information before purchasing a product listed herein.
- Mitsubishi Electric Corporation semiconductors are not designed or manufactured for use in a device or system that is used under circumstances in which human life is potentially at stake. Please contact Mitsubishi Electric Corporation or an authorized Mitsubishi Semiconductor product distributor when considering the use of a product contained herein for any specific purposes, such as apparatus or systems for transportation, vehicular, medical, aerospace, nuclear, or undersea repeater use.
- The prior written approval of Mitsubishi Electric Corporation is necessary to reprint or reproduce in whole or in part these materials.
- If these products or technologies are subject to the Japanese export control restrictions, they must be exported under a license from the Japanese government and cannot be imported into a country other than the approved destination.
Any diversion or reexport contrary to the export control laws and regulations of Japan and/or the country of destination is prohibited.
- Please contact Mitsubishi Electric Corporation or an authorized Mitsubishi Semiconductor product distributor for further details on these materials or the products contained therein.

REVISION DESCRIPTION LIST

3803/3804 GROUP DATA SHEET

Rev. No.	Revision Description	Rev. date
0.1	First Edition; Only including overview. The issue including all information will be released in April.	990315
1.0	Functional descriptions are added.	990525
2.0	<p>All pages; "PRELIMINARY Notice: This is..." eliminated.</p> <p>Page 9; Product names are added into Figure 8.</p> <p>Page 10; Product names are added into Table 3.</p> <p>Page 34; Explanation of "Timer divider" of "8-bit Timers" is revised.</p> <p>Page 52; Explanation of Note 7 is revised.</p> <p>Page 60; Explanation of Note 7 is revised.</p> <p>Page 63; Explanation of "A-D CONVERTER" is revised.</p> <p>Explanations of Figure 56 are partly revised.</p> <p>Page 66; Explanations of "Watchdog Timer Initial Value" and "Watchdog Timer Operations" are revised.</p> <p>Explanations of Figure 60 are partly revised.</p> <p>Page 67; Explanation of "MULTI-MASTER I²C-BUS INTERFACE" is revised.</p> <p>Explanation of Note eliminated.</p> <p>Explanations of Figure 62 are partly revised.</p> <p>Page 68; Explanations of "I²C Data Shift Register" and "I²C Address Registers 0 to 2" are revised.</p> <p>Page 69; Explanation of Bit 5 of "I²C Clock Control Register" is revised.</p> <p>Page 75; Value of "Setup time" and "Hold time" into Table 13 are revised.</p> <p>Page 76; Explanation of Bit 5 of "I²C Special Mode Status Register" is added.</p> <p>Note is added into Figure 73.</p> <p>Page 77; Explanation of Bit 1 of "I²C Special Mode Control Register" is added.</p> <p>Explanation of Bit 6 of "I²C Special Mode Control Register" is revised.</p> <p>Note is added into Figure 74.</p> <p>Page 82; Register Contents of (21) into Figure 78 is revised.</p> <p>Page 86; Explanations of Figure 82 are partly revised.</p> <p>Note 2 into Figure 82 is revised.</p>	990909

REVISION DESCRIPTION LIST

3803/3804 GROUP DATA SHEET

Rev. No.	Revision Description	Rev. date
2.0	Page 117; Table 28 is revised for only flash memory version. Table 29 is added.	990909