

General purpose (dual digital transistors)

EMB11 / UMB11N / IMB11A

●Features

- 1) Two DTA114E chips in a EMT or UMT or SMT package.
- 2) Mounting possible with EMT3 or UMT3 or SMT3 automatic mounting machines.
- 3) Transistor elements are independent, eliminating interference.
- 4) Mounting cost and area can be cut in half.

●Structure

Epitaxial planar type
PNP silicon transistor (Built-in resistor type)

The following characteristics apply to both DT_{r1} and DT_{r2}.

●Equivalent circuit

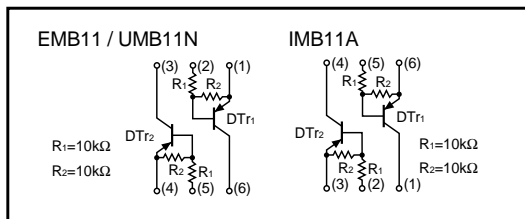

●Absolute maximum ratings (Ta = 25°C)

Parameter	Symbol	Limits	Unit
Supply voltage	V _{CC}	-50	V
Input voltage	V _{IN}	-40	V
		10	
Output current	I _O	-50	mA
	I _{C (Max.)}	-100	
Power dissipation	P _d	150 (TOTAL)	*1
		300 (TOTAL)	*2
Junction temperature	T _j	150	°C
Storage temperature	T _{stg}	-55~+150	°C

*1 120mW per element must not be exceeded.

*2 200mW per element must not be exceeded.

●External dimensions (Units : mm)

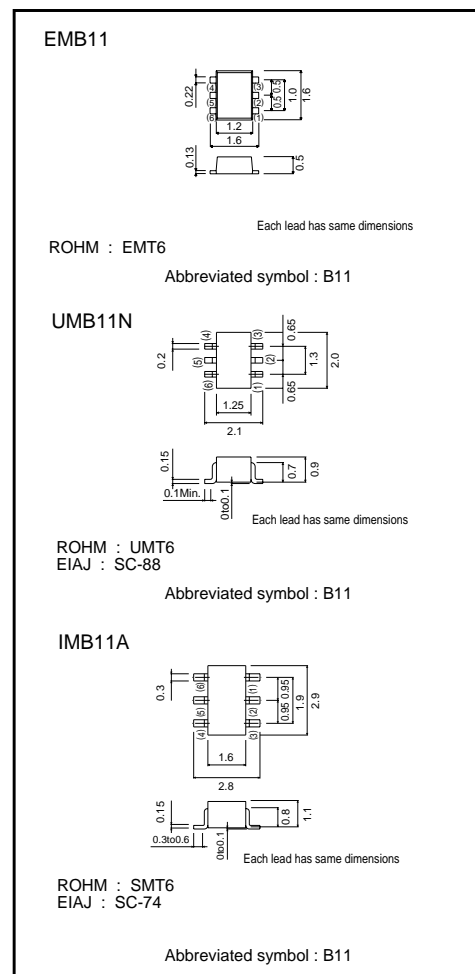

Transistors

●Electrical characteristics (Ta = 25°C)

Parameter	Symbol	Min.	Typ.	Max.	Unit	Conditions
Input voltage	$V_{I(off)}$	-	-	-0.5	V	$V_{CC}=-5V, I_o=-100\mu A$
	$V_{I(on)}$	-3.0	-	-		$V_o=-0.3V, I_o=-10mA$
Output voltage	$V_{O(on)}$	-	0.1	-0.3	V	$I_o/I_i=-10mA/-0.5mA$
Input current	I_i	-	-	-0.88	mA	$V_i=-5V$
Output current	$I_o(off)$	-	-	-0.5	μA	$V_{CC}=-50V, V_i=0V$
DC current gain	G_i	30	-	-	-	$V_o=-5V, I_o=-5mA$
Transition frequency	f_T	-	250	-	MHz	$V_{CE}=10mA, I_E=-5mA, f=100MHz$ *
Input resistance	R_1	7	10	13	$k\Omega$	-
Resistance ratio	R_2 / R_1	0.8	1	1.2	-	-

* Transition frequency of the device

●Packaging specifications

Type	Package	Taping		
	Code	T2R	TR	T148
	Basic ordering unit (pieces)	8000	3000	3000
EMB11	○	—	—	—
UMB11N	—	○	—	—
IMB11A	—	—	—	○

●Electrical characteristic curves

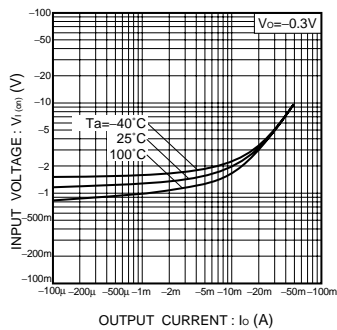

Fig.1 Input voltage vs. output current (ON characteristics)

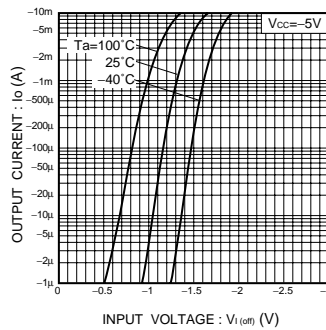

Fig.2 Output current vs. input voltage (OFF characteristics)

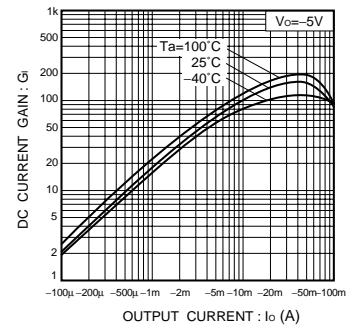

Fig.3 DC current gain vs. output current

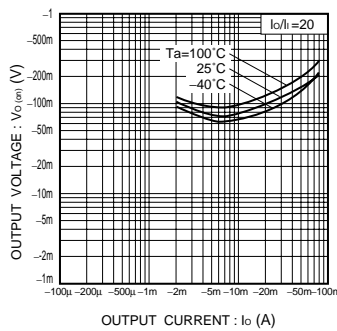

Fig.4 Output voltage vs. output current