

Magnetic Field Sensors

**ZMY20, ZMZ20
ZMY30, ZMZ30**

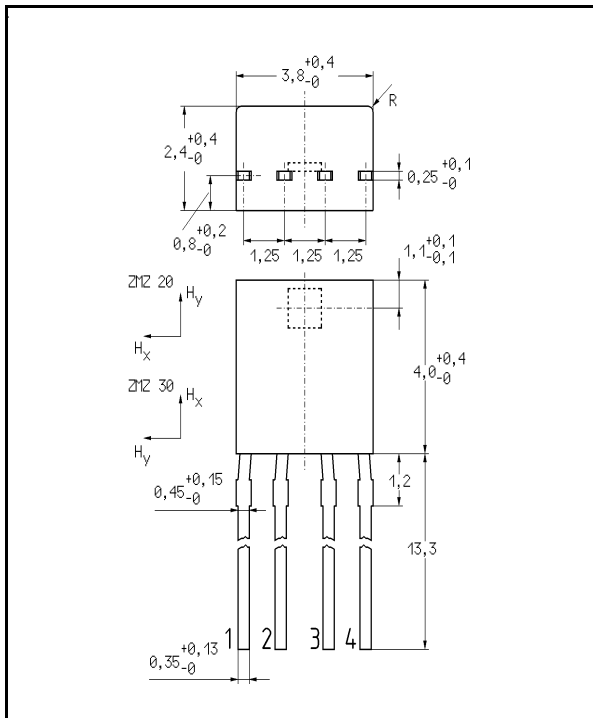

package : E-Line (4-Pin)

1: +V_O 2: -V_B 3: -V_O 4: +V_B

V_O - output voltage V_B - supply voltage

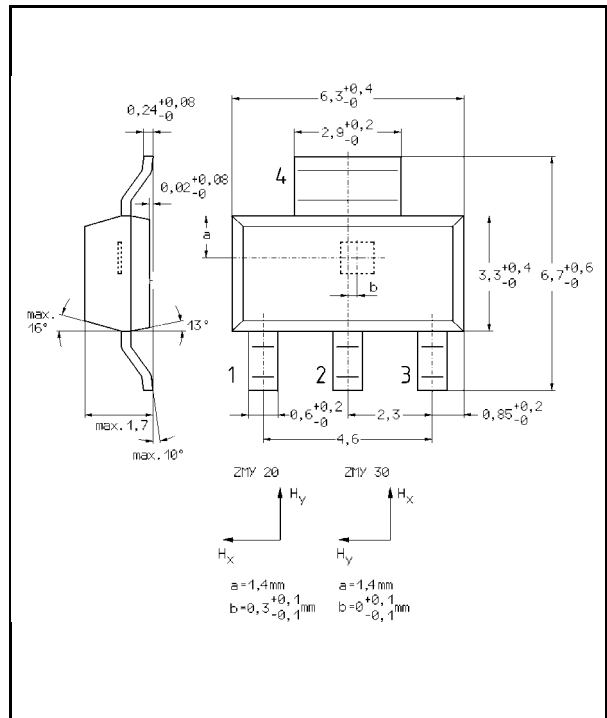

package : SOT223S (4-Pin)

1: +V_O 2: -V_O 3: +V_B 4: -V_B

V_O - output voltage V_B - supply voltage

FEATURES

- ZMZ20/30 (E-Line 4-Pin) and ZMY20/30 (SOT-223-S) are extremely sensitive magnetic sensors employing the magneto-resistive effect of thin film permalloy
- Packages : E-Line 4-Pin and SOT-223-S
- Output voltage proportional to the magnetic field H_y
- Adjustment of sensitivity and suppression of the hysteresis by the auxiliary magnetic field H_x
- Magnetic fields vertical to the chip level are not effective

ABSOLUTE MAXIMUM RATINGS

Parameter	Symbol		Unit
Supply voltage ZMY20/ZMZ20	V _B	12	V
Supply voltage ZMY30/ZMZ30	V _B	15	V
Total power dissipation	P _{tot}	120	mW
Operating temperature range	T _{amb}	-40 to +150	°C
Storage temperature range	T _{stg}	-65 to +150	°C

ZMY20/30, ZMZ 20/30

ELECTRICAL CHARACTERISTICS (at $T_{amb} = 25\text{ °C}$ and $H_x = 3\text{ kA/m}$ unless otherwise stated)

Parameter	Symbol	Min.	Typ.	Max.	Unit	Test conditions
Bridge resistance ZMY20/ZMZ20 ZMY30/ZMZ30	R_{br}	1.2 2.0	1.7 3.0	2.2 4.0	$k\Omega$	
Output voltage range ZMY20/ZMZ20 ZMY30/ZMZ30	V_O/V_B	16 12	20 16	24 20	mV/V	
Open circuit sensitivity ZMY20/ZMZ20 ZMY30/ZMZ30	S	3.7 2.0	4.7 3.0	5.7 4.0	(mV/V)/(kA/m)	no disturbing field H_d allowed
Hysteresis of output voltage	V_{OH}/V_B	-	-	50	$\mu\text{V/V}$	$H_y \leq 2\text{ kA/m}$
Offset voltage	V_{off}/V_B	-1.0	-	+1.0	mV/V	
Operating frequency	f_{max}	0	-	1	MHz	
Temperature coefficient of offset voltage	TCV_{off}	-3	-	+3	($\mu\text{V/V}$)/K	$T_{amb} = -25\dots+125\text{ °C}$
Temperature coefficient of bridge resistance	TCR_{br}	-	0.3	-	%/K	$T_{amb} = -25\dots+125\text{ °C}$
Temperature coefficient of open circuit sensitivity $V_B = 5\text{ V}$	TCS_V	-	-0.4	-	%/K	$T_{amb} = -25\dots+125\text{ °C}$
Temperature coefficient of open circuit sensitivity $I_B = 3\text{ mA}$	TCS_I	-	-0.1	-	%/K	$T_{amb} = -25\dots+125\text{ °C}$

Devices are identified by a code on the body of the device

ZMY20/ZMZ20 M20 ZMY30/ZMZ30 M30

Ordering information:

ZMY20TA 7" reel 1,000 components per reel
 ZMY20TC 13" reel 4,000 components per reel
 ZMY30TA 7" reel 1,000 components per reel
 ZMY30TC 13" reel 4,000 components per reel
 ZMZ20 bulk in box (2,000 components per box)
 ZMZ30 bulk in box (2,000 components per box)

Application 1 (digital output)

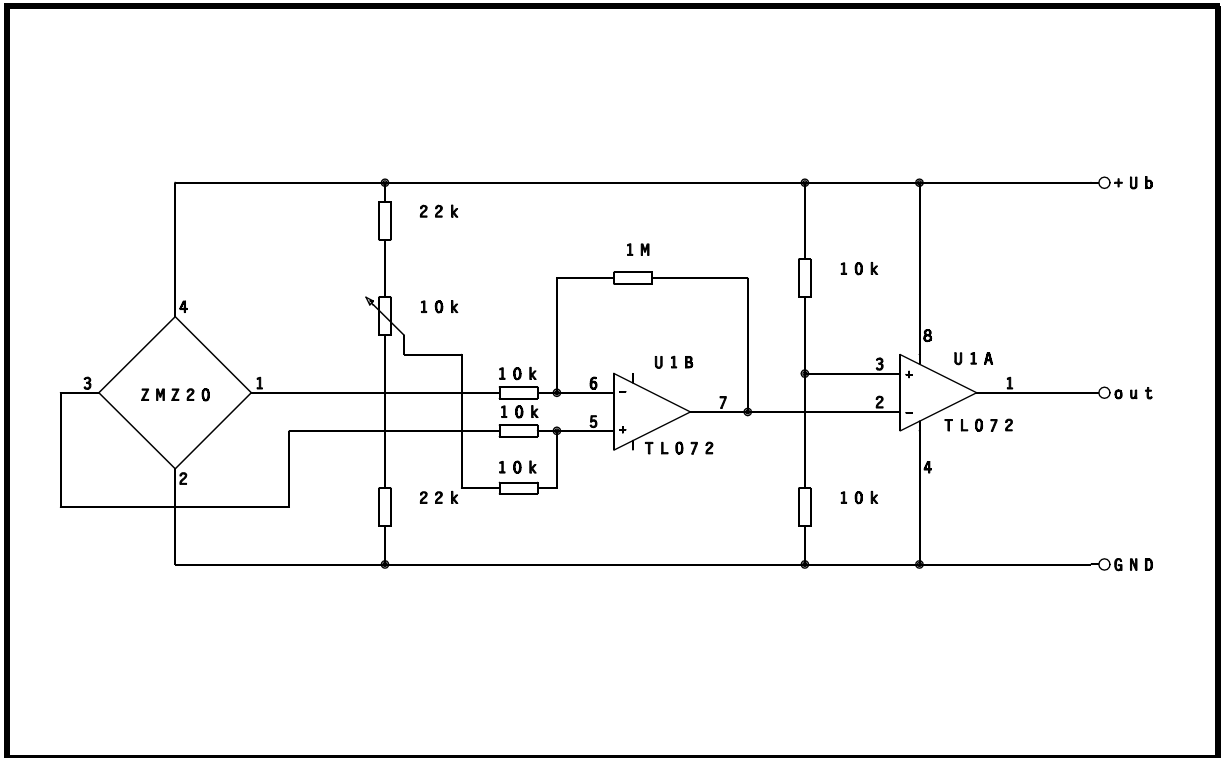

Application 2 (analogue output)

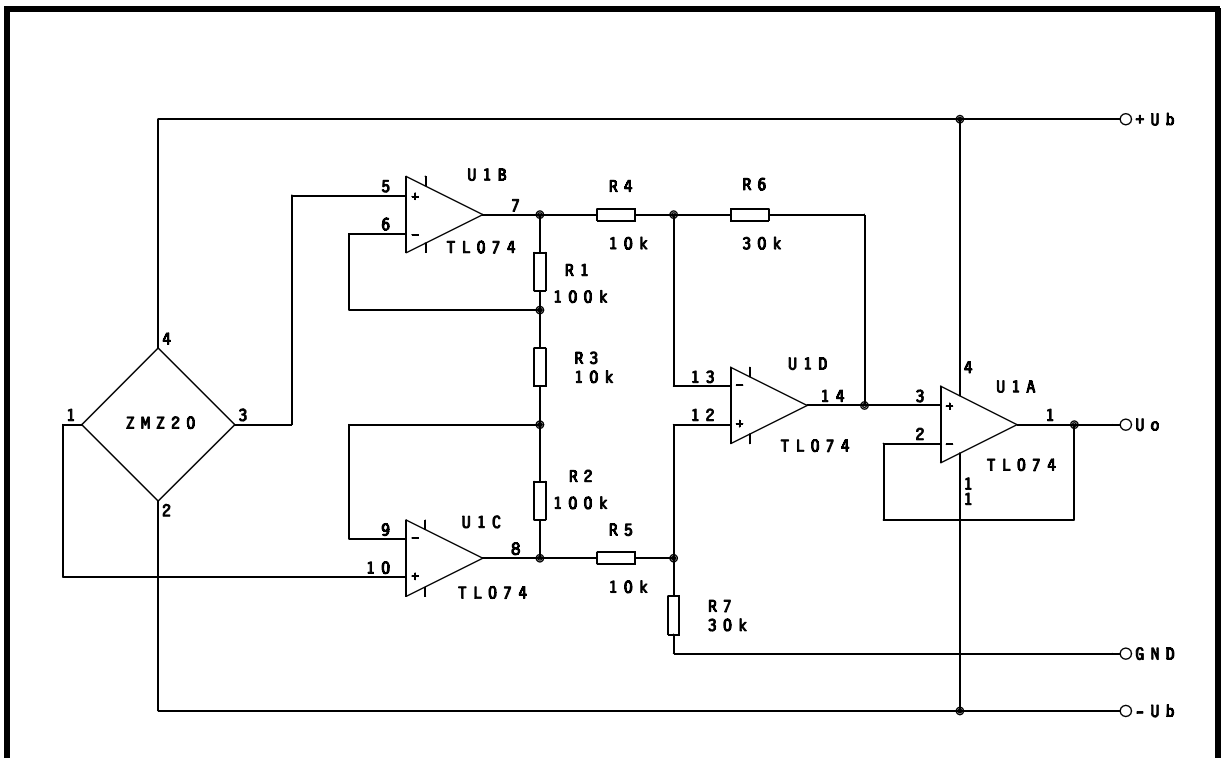

Sensor output characteristic ZMZ 20 / ZMY 20 $V_o = f(H_y); H_x$ - parameter

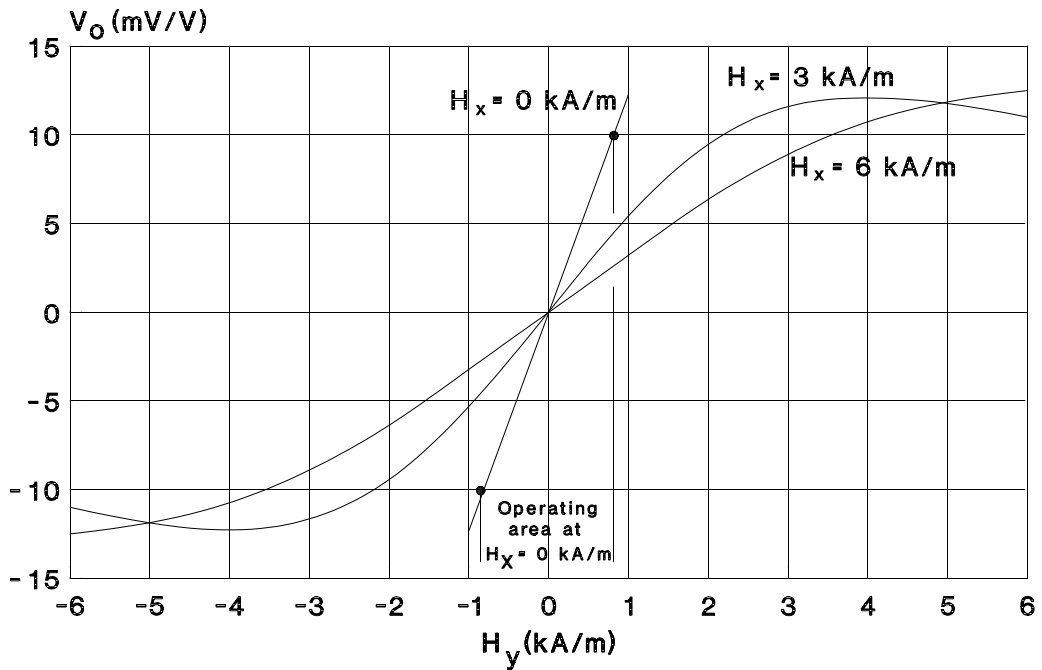

$V_B = \text{const.}; T_{\text{amb}} = 25^\circ\text{C}$

Sensor output characteristic ZMY 30 / ZMZ 30 $V_o = f(H_y); H_x$ - parameter

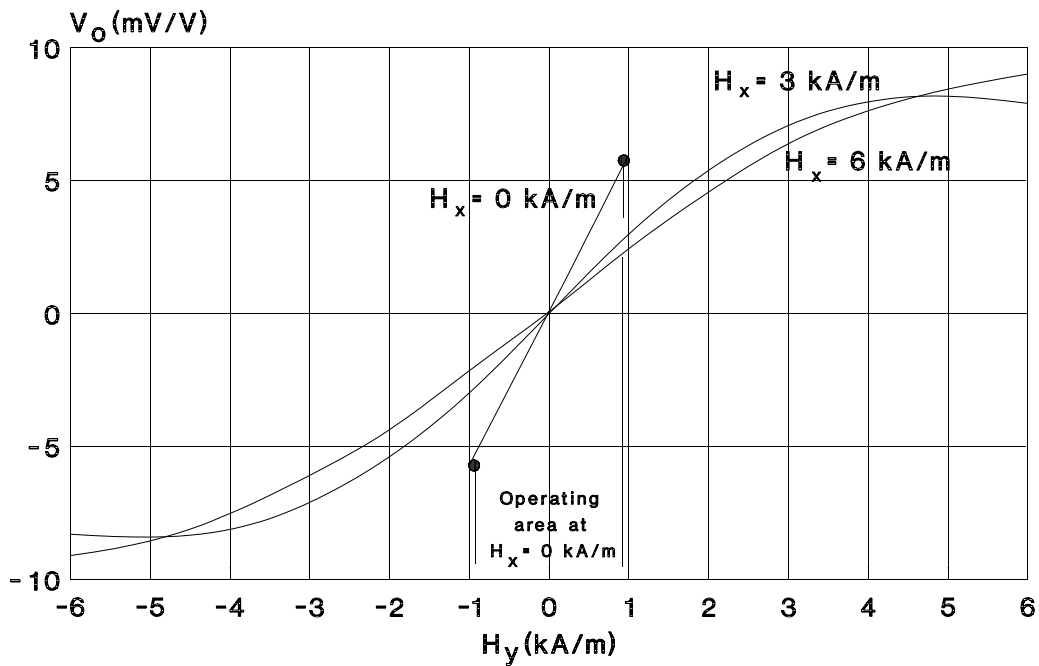

$V_B = \text{const.}; T_{\text{amb}} = 25^\circ\text{C}$

The sensor has to be reset after leaving the safe operating area by an auxiliary field of $H_X = 3$ kA/m.

Safe operating area ZMY20/ZMZ20

$$H_{xtot} = H_x + H_d, T_{amb} = 25\text{ }^\circ\text{C}$$

(H_d - disturbing field)

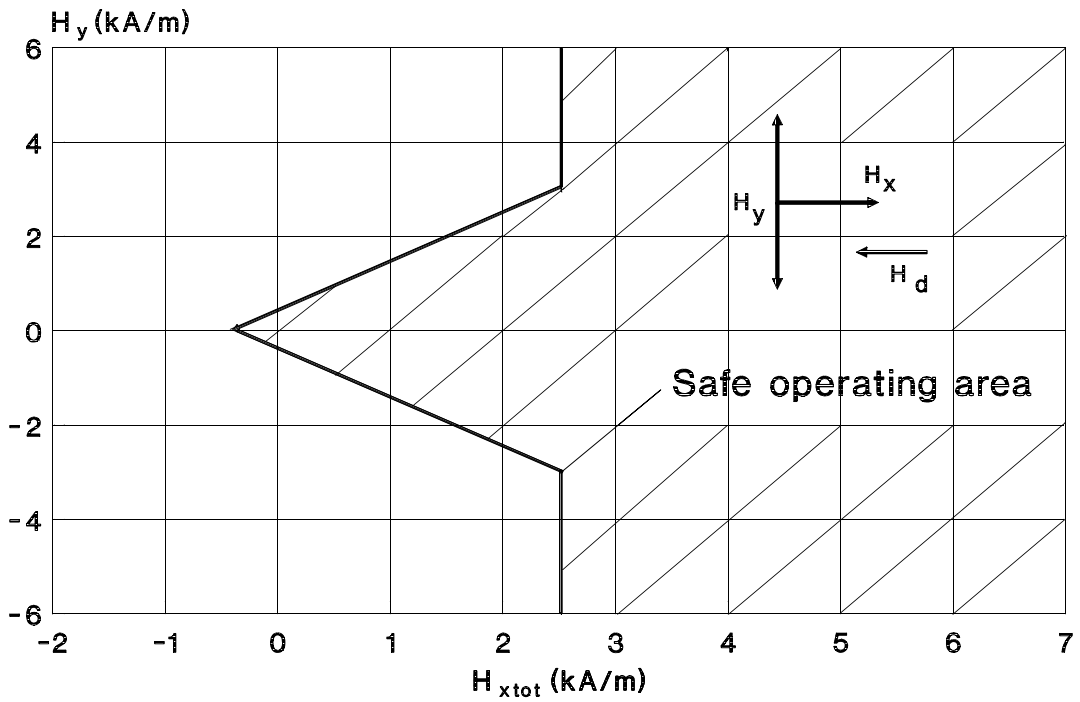

Safe operating area ZMY30/ZMZ30

$$H_{xtot} = H_x + H_d, T_{amb} = 25\text{ }^\circ\text{C}$$

(H_d - disturbing field)

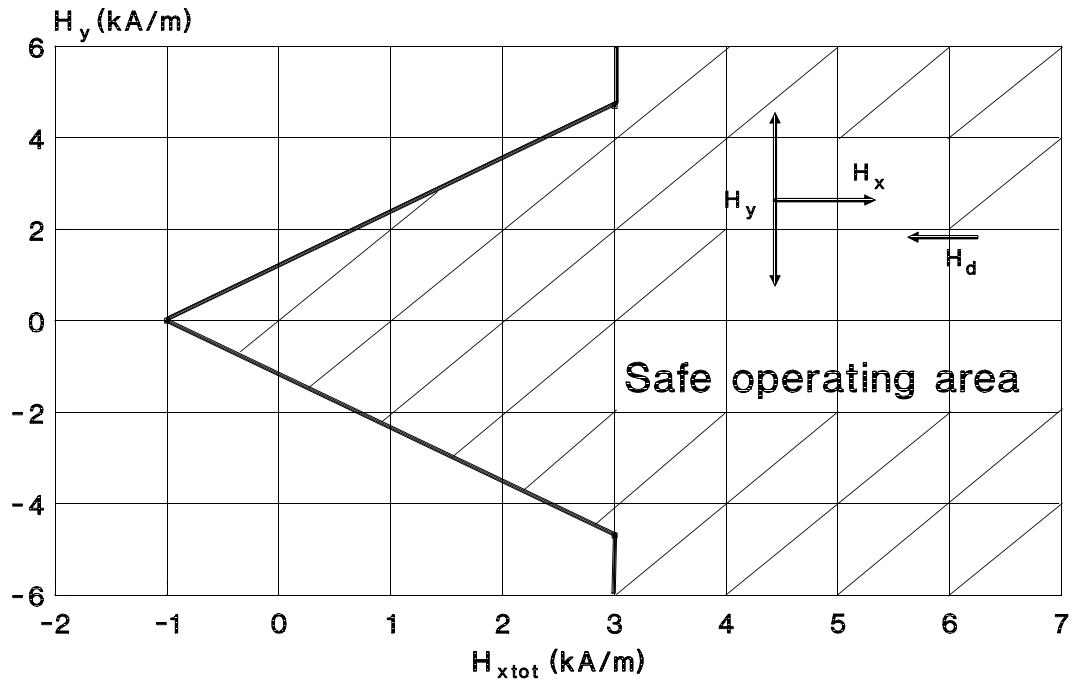

ZMY20/30, ZMZ 20/30

Sensor sensitivity characteristic ZMY 20 / ZMZ 20 $S = f(H_x)$

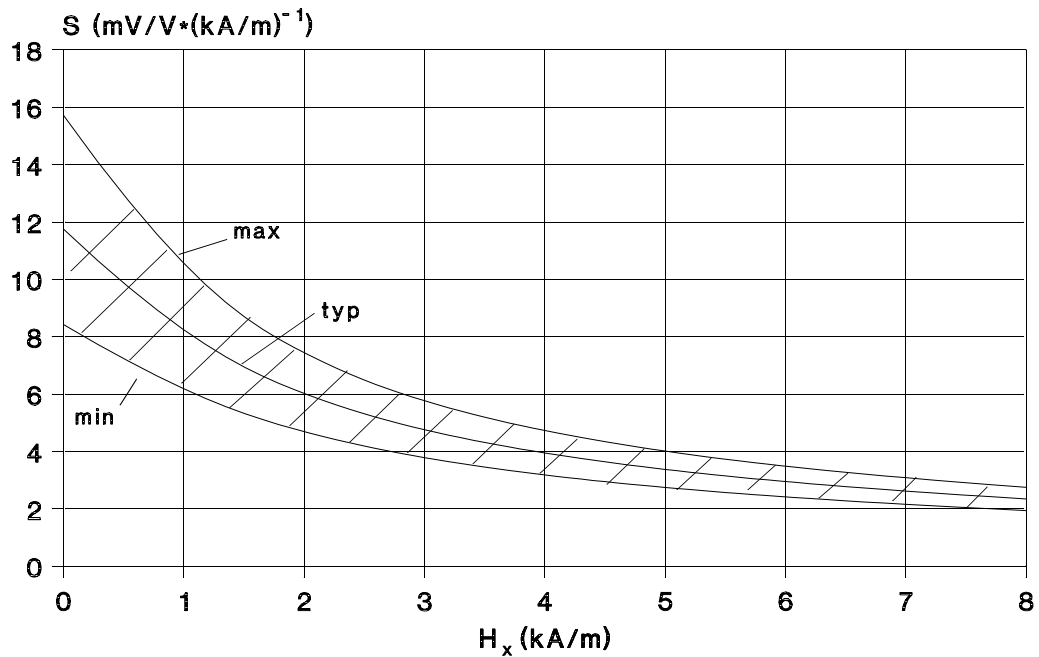

$V_B = \text{const.}; T_{\text{amb}} = 25^\circ\text{C}$

Sensor sensitivity characteristic ZMY 30 / ZMZ 30 $S = f(H_x)$

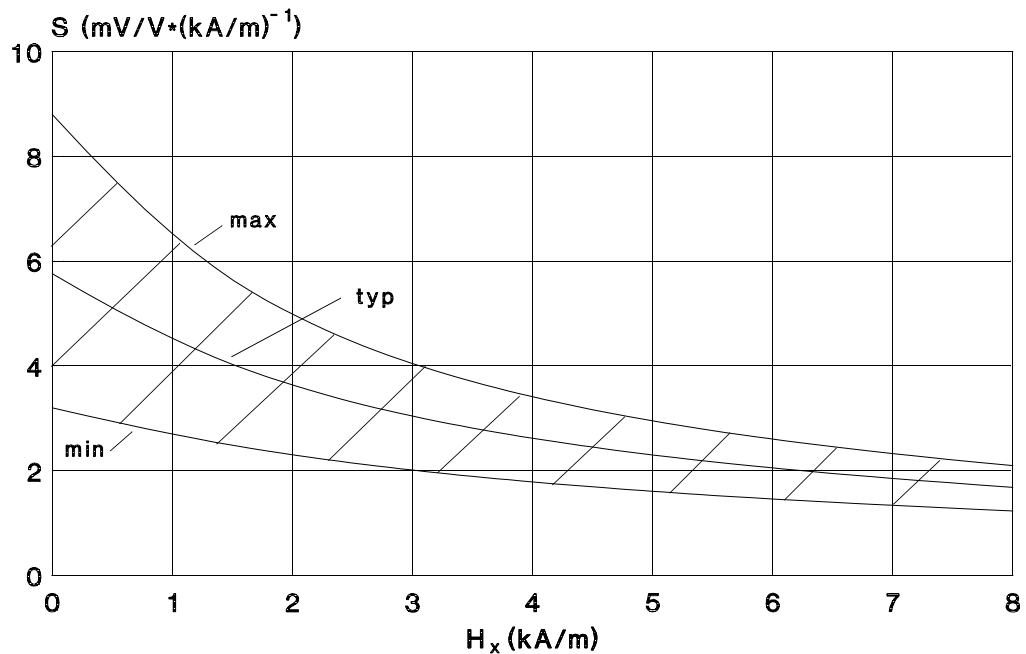

$V_B = \text{const.}; T_{\text{amb}} = 25^\circ\text{C}$

In applications with $H_x < 3 \text{ kA/m}$, the sensor has to be reset by an auxiliary field of $H_x \geq 3 \text{ kA/m}$ before use.

ZMY20/30, ZMZ 20/30

Supply voltage (maximum) derating curve

ZMY 20 / ZMZ 20

$$V_{Bmax} = f(T_{amb})$$

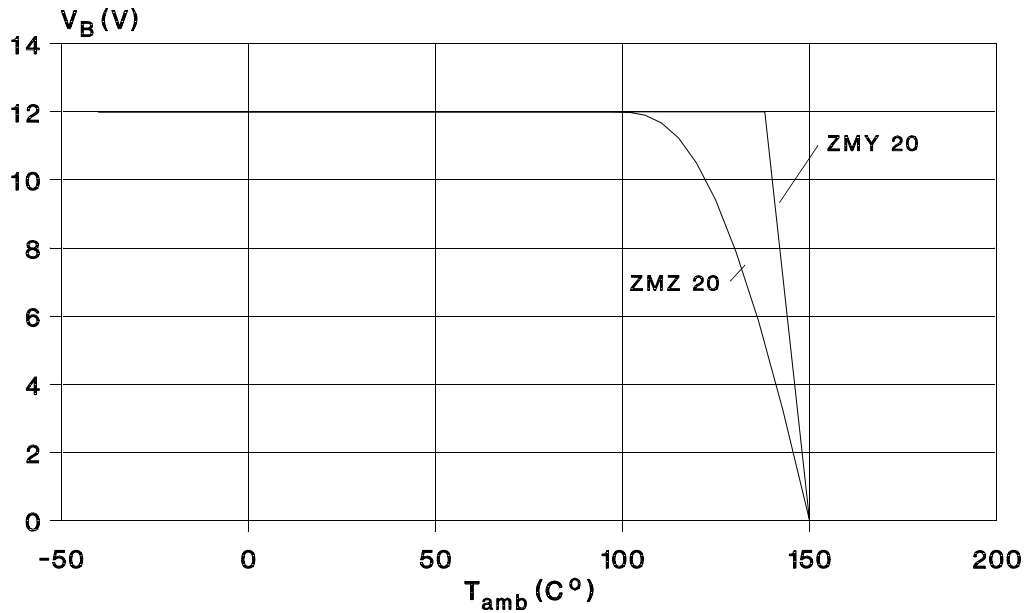

ZMY 20 : Device mounted on 40 x 40 mm² board (copper area 600 mm²)
ZMZ 20 : Device mounted on board (copper area 100 mm²)

Supply voltage (maximum) derating curve

ZMY 30 / ZMZ 30

$$V_{Bmax} = f(T_{amb})$$

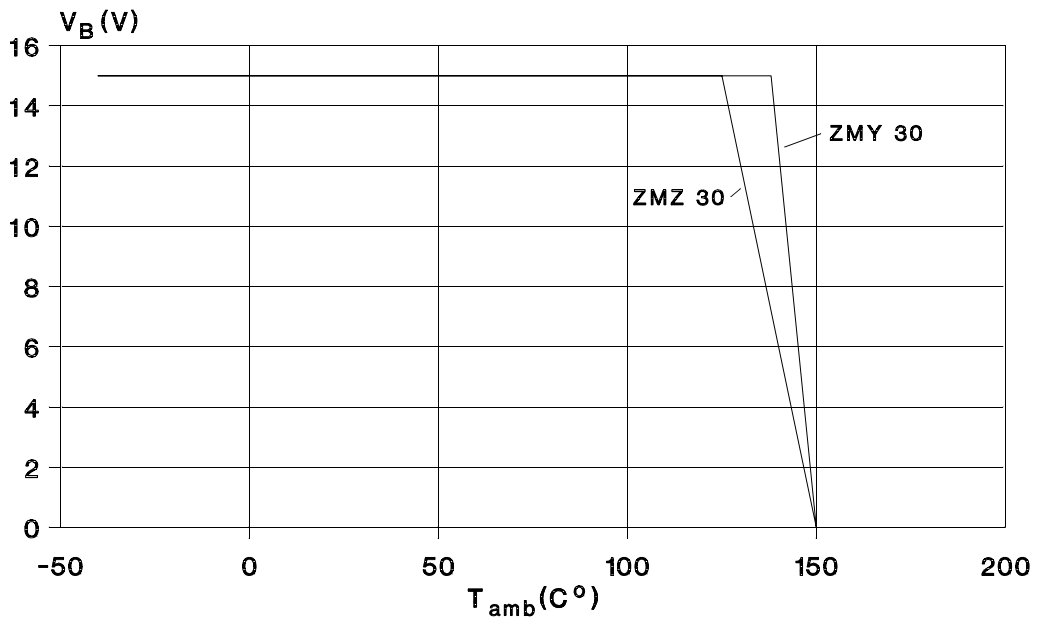

ZMY 30 : Device mounted on 40 x 40 mm² board (copper area 600 mm²)
ZMZ 30 : Device mounted on board (copper area 100 mm²)