

IPIC* High Side Bulb Driver

Description

*(IPIC: Intelligent Power IC)

HA13702A is high side power driver IC with protectors and diagnostic function. The device is especially designed to switch automotive light bulbs using PWM current limiter system.

Functions

- Power MOS source follower output (4 A)
- With over voltage shut down circuit (OVSD)
- With over current protector circuit (PWM OCL)
- With over temperature shut down circuit (OTSD)
- With diagnostic circuit and status output
- With fail safe function under input open circuit condition
- With low voltage inhibit circuit (LVI)
- With output negative voltage clamp circuit

Features

- Protected against 60 V load dump condition
- Low R_{ON} (0.1 Ω typ)
- Wide operating supply voltage range ($V_{DD} = 7\text{ V to }25\text{ V}$)
- Protected against reverse supply voltage (-13 V)
- Protected against output short circuit condition
- Suitable switching speed to have high speed operation and low EMI
- Input compatible with TTL, LS-TTL, or 5 V CMOS
- Protected against electrostatic discharge (2 kV min at 100 pF/1.5 k Ω)

Block Diagram

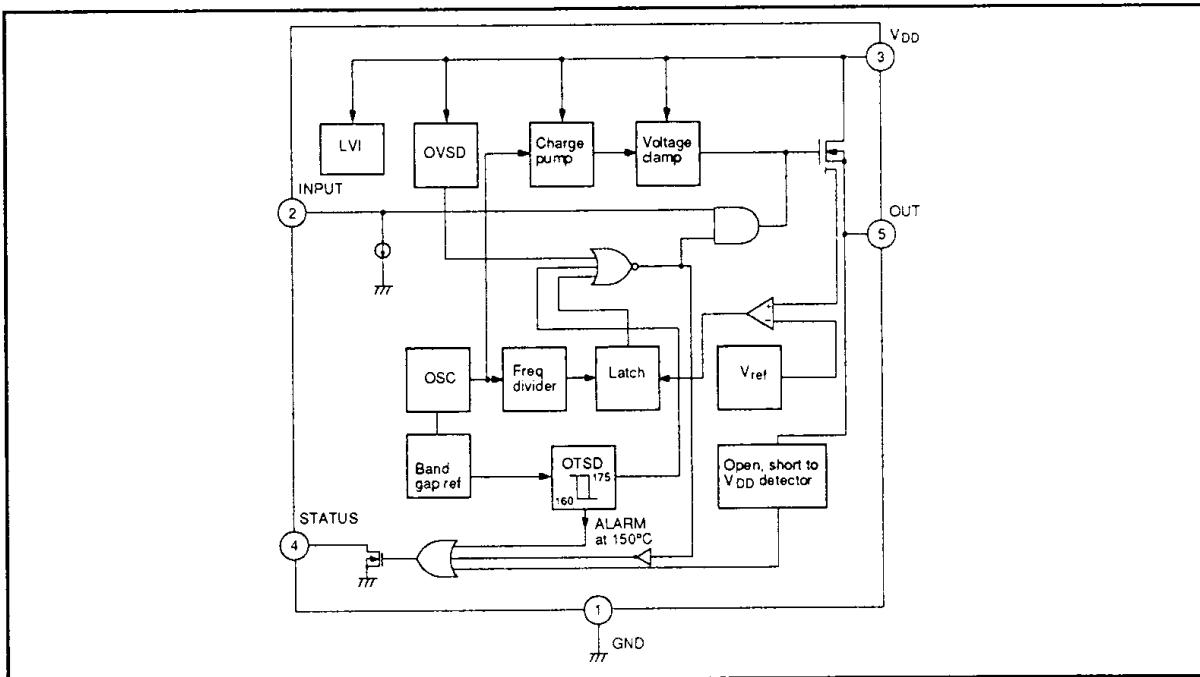
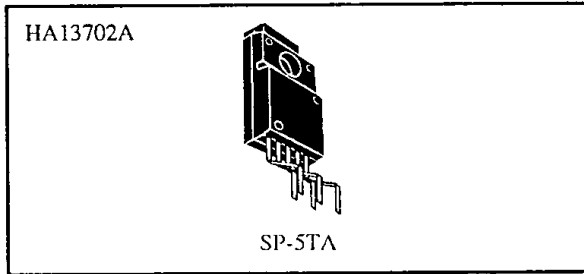
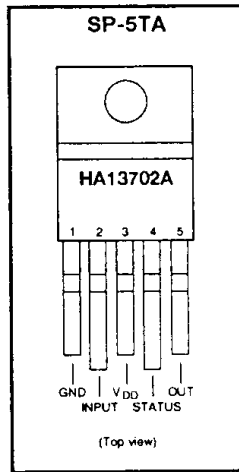

Figure 2 Block Diagram



Pin Arrangement



Ordering Information

Type No.	Package
HA13702A	SP-5TA

Figure 1 Pin Arrangement

HA13702A

Table 1 Truth Table

Mode	In	Out	Status
Normal	L	L	H
	H	H	H
Load short	L	L	H
	H	L	L
Load open	L	L	H
	H	H	L
Short to V _{DD}	L	H	L
	H	H	L
OTSD *1	L	L	L
	H	L	L
OVSD *2	L	L	L
	H	L	L
LVI *3	L	L	H
	H	L	H

Note: L: Low level (0.8 V)
H: High level (2.0 V)

*1) OTSD: Over temperature shut down

*2) OVSD: Over voltage shut down

*3) LVI: Low voltage inhibit

Table 2 Absolute Maximum Ratings (T_a = 25°C)

Item	Symbol	HA13702A	Unit	Note
Continuous supply voltage	V _{DD}	-13 to +35	V	1
Transient supply voltage	V _{DD}	60	V	2
Input voltage	V _{IN}	-0.3 to +15	V	
Output voltage	V _{out}	V _{DD}	V	
Status voltage	V _S	-0.3 to 15	V	
Output current	I _{out}	—	A	3
Status current	I _S	5	mA	
Power dissipation	P _T	—	W	4
Package thermal resistance	Junction to case	θ _{jc}	5	°C/W
	Junction to air	θ _{ja}	70	°C/W
Junction temperature range	T _j	-40 to OTSD	°C	5
Storage temperature range	T _{stg}	-55 to 150	°C	

The absolute maximum ratings are limiting values, to be applied individually, beyond which the device may be permanently damaged. Functional operation under any of these conditions is not guaranteed. Exposing a circuit to its absolute maximum rating for extended periods of time may affect the device's reliability.

Notes: 1. Recommended operating voltage:

V_{DD} = 7 to 16 V (Normal)
16 to 25 V (Jump start)

2. Load dump condition

3. Internally limited

4. Maximum power dissipation (P_{T(MAX)}) can be defined as:

$$P_T(\text{MAX}) = (T_{jopr}(\text{MAX}) - T_{\text{ambient}}) / (\theta_{jc} + \theta_{ca})$$

θ_{ca}: Thermal resistance between case and air (Depend on heat sink size)

5. Operating junction temperature range

T_{jopr} = -40 to +125°C

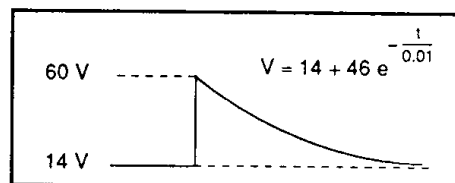
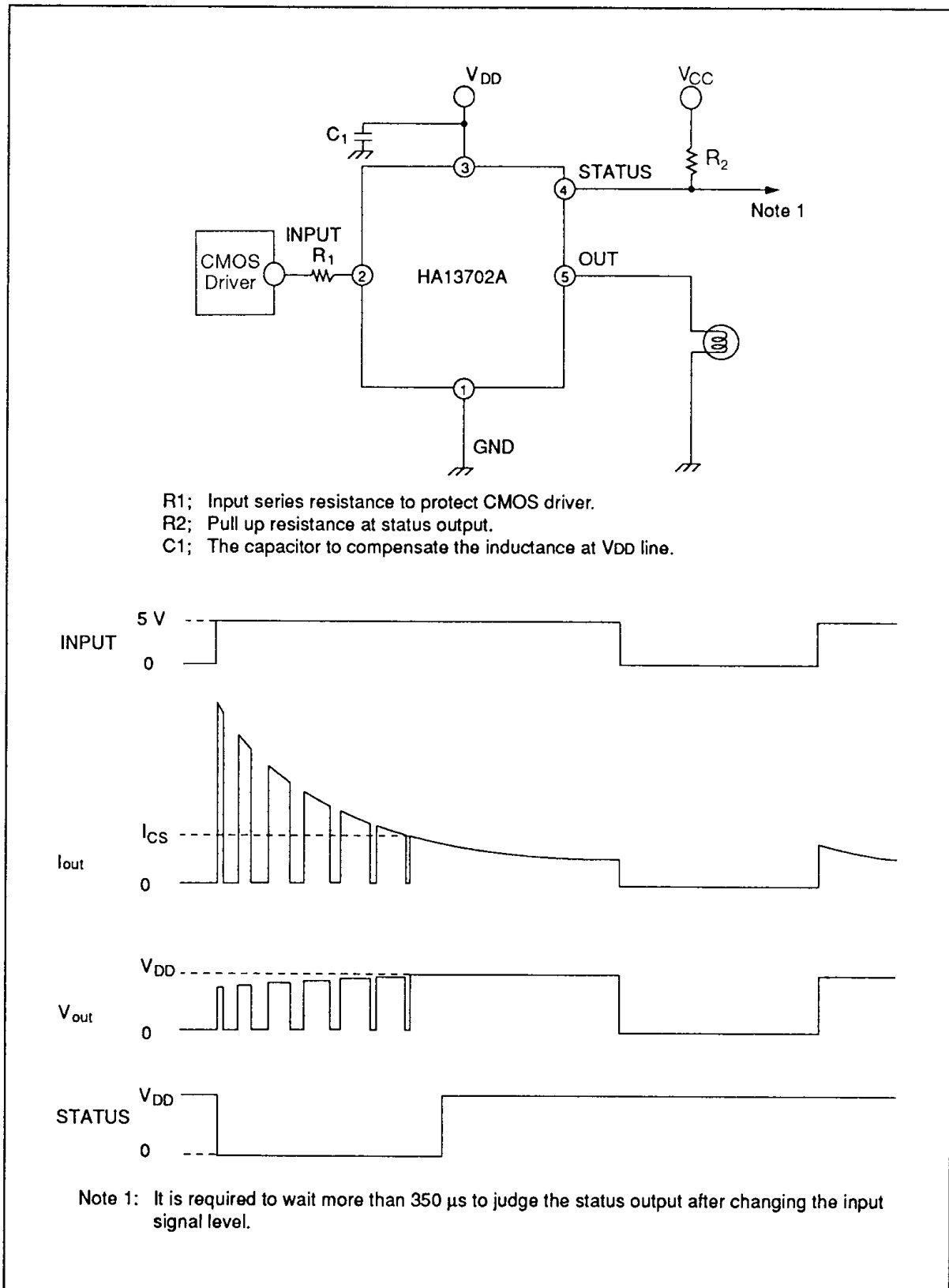

Table 3 Electrical Characteristics (Ta = 25°C)

Item	Symbol	Min	Typ	Max	Unit	Test condition	Pin	Note	
Output R _(ON)	R _{DS(ON)}	—	0.1	0.15	Ω	I _o = 4 A (@T _j = -40 to 25°C)	5		
		—	0.15	0.22	Ω	I _o = 4 A (@T _j = 125°C)	5		
Operating supply voltage range	V _{DD}	7	—	25	V		3		
Quiescent current	I _{DD1}	—	3	5	mA	V _{IN} = 0 V, out = open	3		
	I _{DD2}	—	6	10	mA	V _{IN} = 5.5 V, out = open	3		
Output leak current	I _{LEAK}	—	—	100	μA	V _{DD} = 35 V, V _{IN} = 0 V, T _j = 125°C	5		
Input threshold voltage	V _{IL}	—	—	0.8	V		2		
	V _{IH}	2.0	—	—	V		2		
Input current	I _{IL}	-10	—	60	μA	V _{IN} = 0 to 0.8 V	2		
	I _{IH}	5	35	60	μA	V _{IN} = 2.0 to 5.5 V	2		
Propagation delay time	T _{d(ON)}	—	20	—	μs	I _o = 3 A	2, 5		
	T _r	—	50	—	μs		5		
	T _{d(OFF)}	—	20	—	μs		2, 5		
	T _f	—	10	—	μs		5		
Open detect threshold current	I _{OD}	0.3	0.7	1.2	A		4, 5		
Current limiter operating level	I _{CS}	10	15	20	A		5	1	
Low Voltage Inhibit operating level	L.V.I	—	5	6	V				
Over voltage shut down	Operating level	OVSD	26	30	33	V		3	
	Hysteresys	V _{HYS}	—	0.5	1.0	V		3	
Over temperature shut down	Operating level	OTSD	—	175	—	°C		5	2
		OTSD (Alarm)	—	150	—			4	2
	Hysteresys	T _{HYS}	—	15	—	°C		5	2
Status on voltage	V _{SL}	—	0.1	0.4	V	I _S = 1 mA	4		
Status leak current	I _{S(Leak)}	—	—	100	μA	V _S = 5.5 V	4		

- Notes: 1. Output current will be PWM controlled under current limit condition.
2. Design parameter only (no test)

Bulb Drive Application and Its Waveform



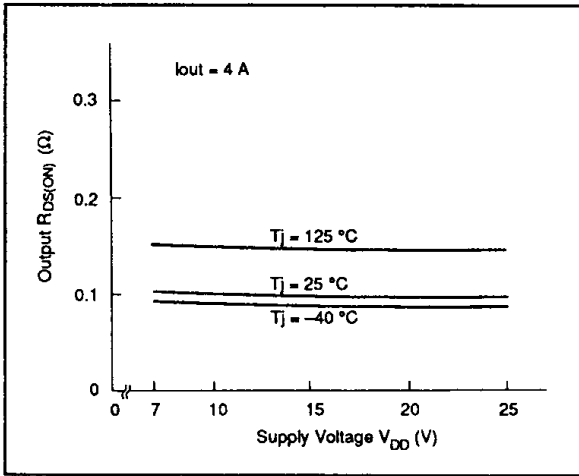

$R_{DS(ON)}$ vs. V_{DD}

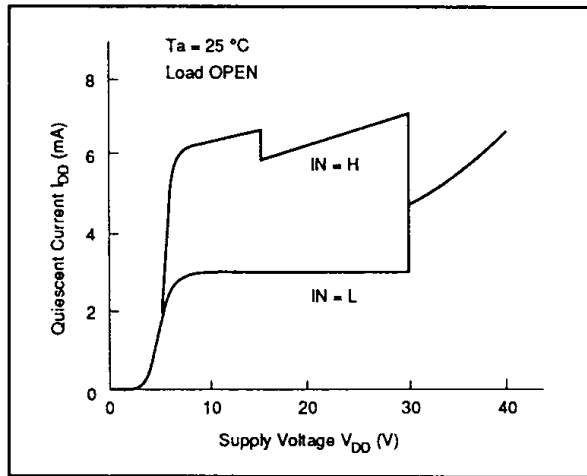

I_{DD} vs. V_{DD}

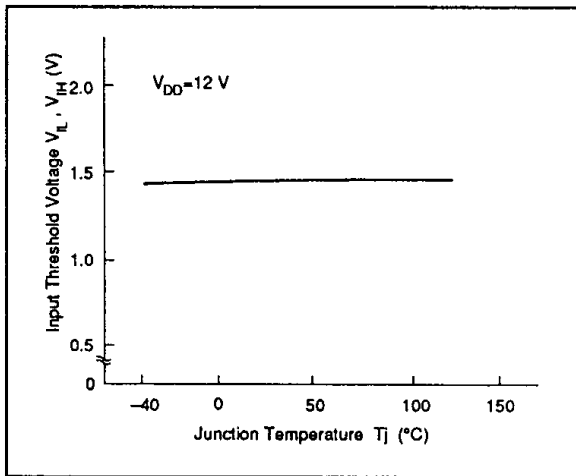

V_{IL} , V_{IH} vs. T_j

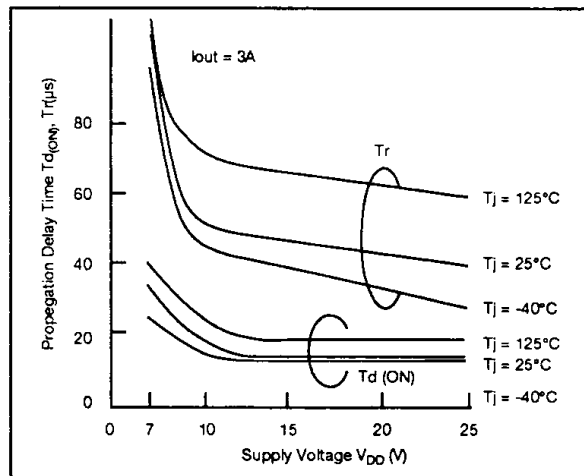

$T_{d(ON)}$, T_r vs. V_{DD}

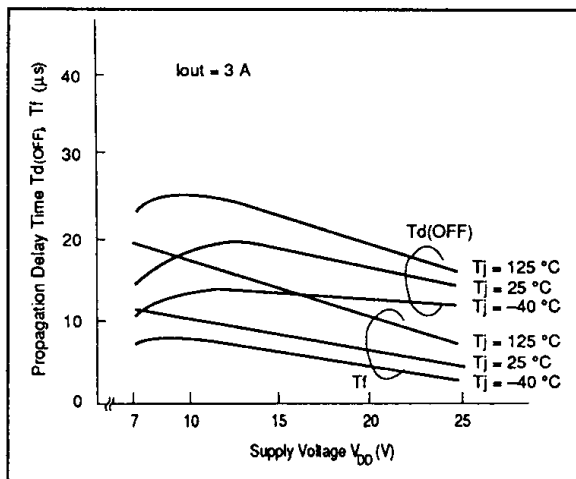

$T_{d(OFF)}$, T_f vs. V_{DD}

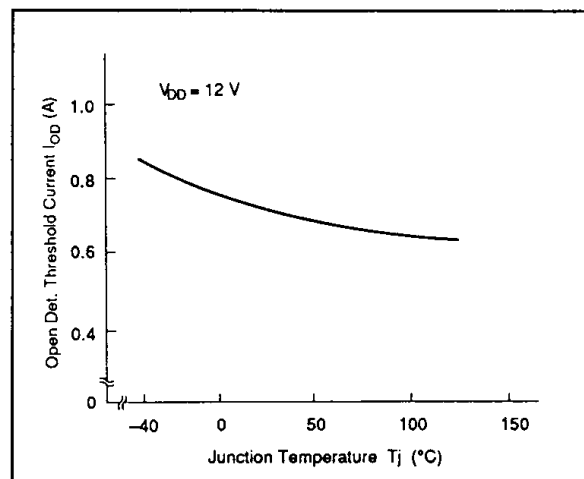

I_{OD} vs. T_j



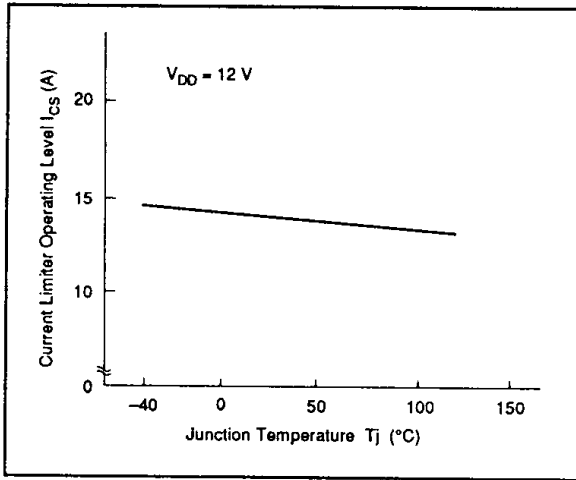

I_{CS} vs. T_j

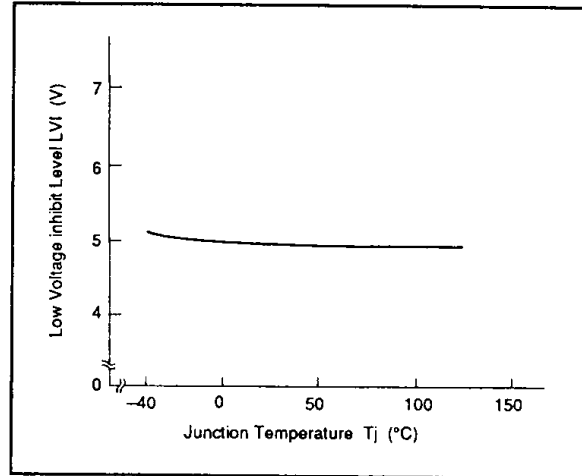

L_{VI} vs. T_j

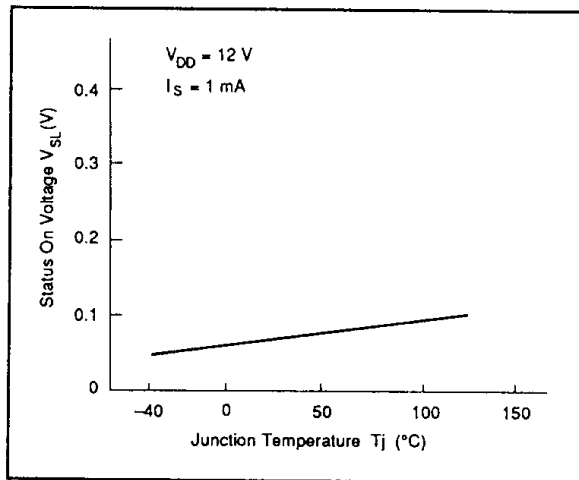

V_{SL} vs. T_j

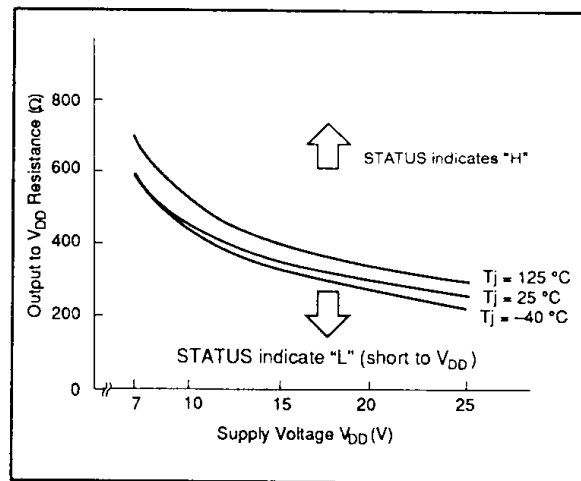

Short to V_{DD}