

---

## Features

- Compatible with MCS-51<sup>®</sup> Products
- 32K Bytes of Reprogrammable Flash Memory
- Endurance: 1000 Write/Erase Cycles
- 4V to 5.5V Operating Range
- Fully Static Operation: 0 Hz to 33 MHz
- Three-level Program Memory Lock
- 512 x 8-bit Internal RAM
- 32 Programmable I/O Lines
- Three 16-bit Timer/Counters
- Eight Interrupt Sources
- Programmable Serial Channel
- Low-power Idle and Power-down Modes
- Interrupt Recovery from Power-down Mode
- Hardware Watchdog Timer
- Dual Data Pointer
- Power-off Flag

## Description

The AT89C51RC is a low-power, high-performance CMOS 8-bit microcontroller with 32K bytes of Flash programmable read only memory and 512 bytes of RAM. The device is manufactured using Atmel's high-density nonvolatile memory technology and is compatible with the industry-standard 80C51 and 80C52 instruction set and pinout. The on-chip Flash allows the program memory to be user programmed by a conventional nonvolatile memory programmer. A total of 512 bytes of internal RAM are available in the AT89C51RC. The 256-byte expanded internal RAM is accessed via MOVX instructions after clearing bit 1 in the SFR located at address 8EH. The other 256-byte RAM segment is accessed the same way as the Atmel AT89-series and other 8052-compatible products. By combining a versatile 8-bit CPU with Flash on a monolithic chip, the Atmel AT89C51RC is a powerful microcomputer which provides a highly-flexible and cost-effective solution to many embedded control applications.

The AT89C51RC provides the following standard features: 32K bytes of Flash, 512 bytes of RAM, 32 I/O lines, three 16-bit timer/counters, a six-vector two-level interrupt architecture, a full duplex serial port, on-chip oscillator, and clock circuitry. In addition, the AT89C51RC is designed with static logic for operation down to zero frequency and supports two software selectable power saving modes. The Idle Mode stops the CPU while allowing the RAM, timer/counters, serial port, and interrupt system to continue functioning. The Power-down mode saves the RAM contents but freezes the oscillator, disabling all other chip functions until the next external interrupt or hardware reset.



---

## 8-bit Microcontroller with 32K Bytes Flash

---

## AT89C51RC

Rev. 1920B-MICRO-11/02



# Pin Configurations

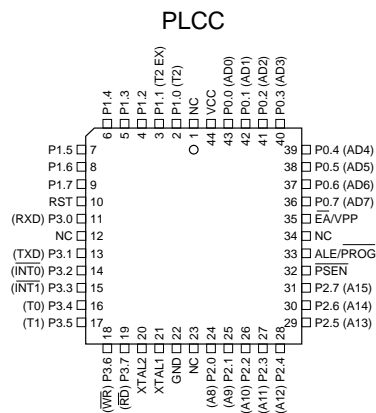
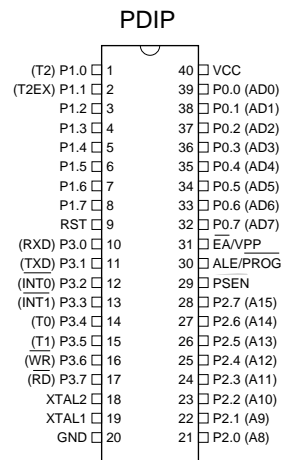
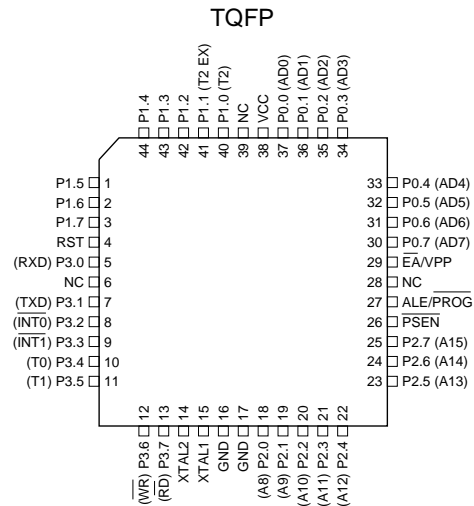

Block Diagram

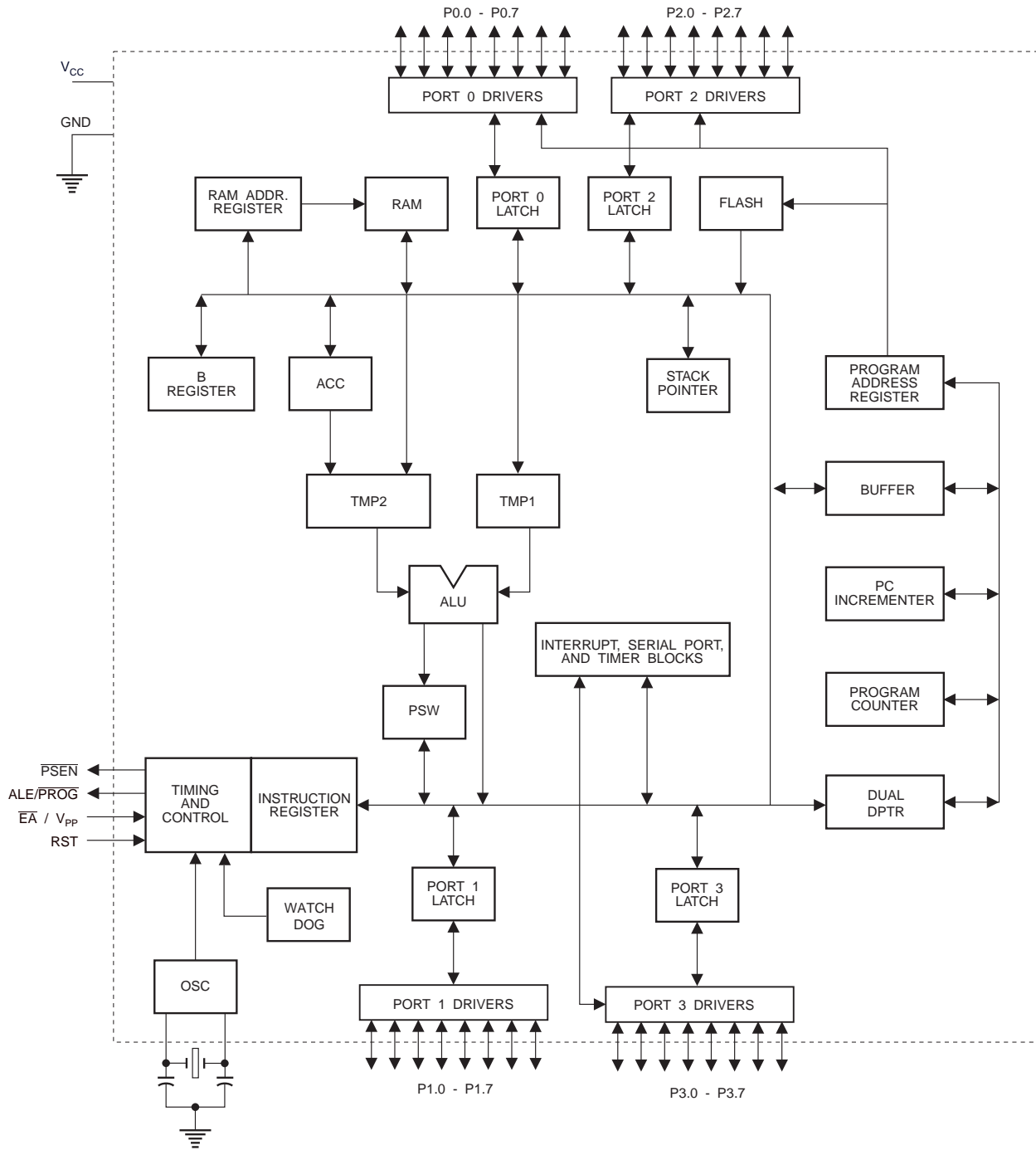



## Pin Description

**VCC** Supply voltage.

**GND** Ground.

**Port 0** Port 0 is an 8-bit open drain bidirectional I/O port. As an output port, each pin can sink eight TTL inputs. When 1s are written to port 0 pins, the pins can be used as high-impedance inputs.

Port 0 can also be configured to be the multiplexed low-order address/data bus during accesses to external program and data memory. In this mode, P0 has internal pull-ups.

Port 0 also receives the code bytes during Flash programming and outputs the code bytes during program verification. **External pull-ups are required during program verification.**

**Port 1** Port 1 is an 8-bit bidirectional I/O port with internal pull-ups. The Port 1 output buffers can sink/source four TTL inputs. When 1s are written to Port 1 pins, they are pulled high by the internal pull-ups and can be used as inputs. As inputs, Port 1 pins that are externally being pulled low will source current ( $I_{IL}$ ) because of the internal pull-ups.

In addition, P1.0 and P1.1 can be configured to be the timer/counter 2 external count input (P1.0/T2) and the timer/counter 2 trigger input (P1.1/T2EX), respectively, as shown in the following table.

Port 1 also receives the low-order address bytes during Flash programming and verification.

Port Pin	Alternate Functions
P1.0	T2 (external count input to Timer/Counter 2), clock-out
P1.1	T2EX (Timer/Counter 2 capture/reload trigger and direction control)

**Port 2** Port 2 is an 8-bit bidirectional I/O port with internal pull-ups. The Port 2 output buffers can sink/source four TTL inputs. When 1s are written to Port 2 pins, they are pulled high by the internal pull-ups and can be used as inputs. As inputs, Port 2 pins that are externally being pulled low will source current ( $I_{IL}$ ) because of the internal pull-ups.

Port 2 emits the high-order address byte during fetches from external program memory and during accesses to external data memory that use 16-bit addresses (MOVX @ DPTR). In this application, Port 2 uses strong internal pull-ups when emitting 1s. During accesses to external data memory that use 8-bit addresses (MOVX @ RI), Port 2 emits the contents of the P2 Special Function Register.

Port 2 also receives the high-order address bits and some control signals during Flash programming and verification.

**Port 3** Port 3 is an 8-bit bidirectional I/O port with internal pull-ups. The Port 3 output buffers can sink/source four TTL inputs. When 1s are written to Port 3 pins, they are pulled high by the internal pull-ups and can be used as inputs. As inputs, Port 3 pins that are externally being pulled low will source current ( $I_{IL}$ ) because of the pull-ups.

Port 3 receives some control signals for Flash programming and verification.

Port 3 also serves the functions of various special features of the AT89C51RC, as shown in the following table.

Port Pin	Alternate Functions
P3.0	RXD (serial input port)
P3.1	TXD (serial output port)
P3.2	$\overline{\text{INT0}}$ (external interrupt 0)
P3.3	$\overline{\text{INT1}}$ (external interrupt 1)
P3.4	T0 (timer 0 external input)
P3.5	T1 (timer 1 external input)
P3.6	$\overline{\text{WR}}$ (external data memory write strobe)
P3.7	$\overline{\text{RD}}$ (external data memory read strobe)

**RST** Reset input. A high on this pin for two machine cycles while the oscillator is running resets the device. This pin drives High for 98 oscillator periods after the Watchdog times out. The DISRTO bit in SFR AUXR (address 8EH) can be used to disable this feature. In the default state of bit DISRTO, the RESET HIGH out feature is enabled.

**ALE/PROG** Address Latch Enable is an output pulse for latching the low byte of the address during accesses to external memory. This pin is also the program pulse input ( $\overline{\text{PROG}}$ ) during Flash programming.

In normal operation, ALE is emitted at a constant rate of 1/6 the oscillator frequency and may be used for external timing or clocking purposes. Note, however, that one ALE pulse is skipped during each access to external data memory.

If desired, ALE operation can be disabled by setting bit 0 of SFR location 8EH. With the bit set, ALE is active only during a MOVX or MOVC instruction. Otherwise, the pin is weakly pulled high. Setting the ALE-disable bit has no effect if the microcontroller is in external execution mode.

**$\overline{\text{PSEN}}$**  Program Store Enable is the read strobe to external program memory.

When the AT89C51RC is executing code from external program memory,  $\overline{\text{PSEN}}$  is activated twice each machine cycle, except that two  $\overline{\text{PSEN}}$  activations are skipped during each access to external data memory.

**$\overline{\text{EA/VP}}$**  External Access Enable.  $\overline{\text{EA}}$  must be strapped to GND in order to enable the device to fetch code from external program memory locations starting at 0000H up to FFFFH. Note, however, that if lock bit 1 is programmed,  $\overline{\text{EA}}$  will be internally latched on reset.

$\overline{\text{EA}}$  should be strapped to  $V_{CC}$  for internal program executions.

This pin also receives the 12-volt programming enable voltage ( $V_{PP}$ ) during Flash programming.

**XTAL1** Input to the inverting oscillator amplifier and input to the internal clock operating circuit.

**XTAL2** Output from the inverting oscillator amplifier.

**Table 1.** AT89C51RC SFR Map and Reset Values

0F8H									0FFH
0F0H	B 00000000								0F7H
0E8H									0EFH
0E0H	ACC 00000000								0E7H
0D8H									0DFH
0D0H	PSW 00000000								0D7H
0C8H	T2CON 00000000	T2MOD XXXXXX00	RCAP2L 00000000	RCAP2H 00000000	TL2 00000000	TH2 00000000			0CFH
0C0H									0C7H
0B8H	IP XX000000								0BFH
0B0H	P3 11111111								0B7H
0A8H	IE 0X000000								0AFH
0A0H	P2 11111111		AUXR1 XXXXXX0				WDTRST XXXXXXXX		0A7H
98H	SCON 00000000	SBUF XXXXXXXX							9FH
90H	P1 11111111								97H
88H	TCON 00000000	TMOD 00000000	TL0 00000000	TL1 00000000	TH0 00000000	TH1 00000000	AUXR XXX00X00		8FH
80H	P0 11111111	SP 0000111	DP0L 00000000	DP0H 00000000	DP1L 00000000	DP1H 00000000		PCON 0XXX0000	87H

## Special Function Registers

A map of the on-chip memory area called the Special Function Register (SFR) space is shown in Table 1.

Note that not all of the addresses are occupied, and unoccupied addresses may not be implemented on the chip. Read accesses to these addresses will in general return random data, and write accesses will have an indeterminate effect.

User software should not write 1s to these unlisted locations, since they may be used in future products to invoke new features. In that case, the reset or inactive values of the new bits will always be 0.

**Timer 2 Registers:** Control and status bits are contained in registers T2CON (shown in Table 2) and T2MOD (shown in Table 3) for Timer 2. The register pair (RCAP2H, RCAP2L) are the Capture/Reload registers for Timer 2 in 16-bit capture mode or 16-bit auto-reload mode.

**Interrupt Registers:** The individual interrupt enable bits are in the IE register. Two priorities can be set for each of the six interrupt sources in the IP register.

**Table 2. T2CON – Timer/Counter 2 Control Register**

T2CON Address = 0C8H					Reset Value = 0000 0000B			
Bit Addressable								
Bit	TF2	EXF2	RCLK	TCLK	EXEN2	TR2	$C/\overline{T2}$	$CP/\overline{RL2}$
	7	6	5	4	3	2	1	0

Symbol	Function
TF2	Timer 2 overflow flag set by a Timer 2 overflow and must be cleared by software. TF2 will not be set when either RCLK = 1 or TCLK = 1.
EXF2	Timer 2 external flag set when either a capture or reload is caused by a negative transition on T2EX and EXEN2 = 1. When Timer 2 interrupt is enabled, EXF2 = 1 will cause the CPU to vector to the Timer 2 interrupt routine. EXF2 must be cleared by software. EXF2 does not cause an interrupt in up/down counter mode (DCEN = 1).
RCLK	Receive clock enable. When set, causes the serial port to use Timer 2 overflow pulses for its receive clock in serial port Modes 1 and 3. RCLK = 0 causes Timer 1 overflow to be used for the receive clock.
TCLK	Transmit clock enable. When set, causes the serial port to use Timer 2 overflow pulses for its transmit clock in serial port Modes 1 and 3. TCLK = 0 causes Timer 1 overflows to be used for the transmit clock.
EXEN2	Timer 2 external enable. When set, allows a capture or reload to occur as a result of a negative transition on T2EX if Timer 2 is not being used to clock the serial port. EXEN2 = 0 causes Timer 2 to ignore events at T2EX.
TR2	Start/Stop control for Timer 2. TR2 = 1 starts the timer.
$C/\overline{T2}$	Timer or counter select for Timer 2. $C/\overline{T2}$ = 0 for timer function. $C/\overline{T2}$ = 1 for external event counter (falling edge triggered).
$CP/\overline{RL2}$	Capture/Reload select. $CP/\overline{RL2}$ = 1 causes captures to occur on negative transitions at T2EX if EXEN2 = 1. $CP/\overline{RL2}$ = 0 causes automatic reloads to occur when Timer 2 overflows or negative transitions occur at T2EX when EXEN2 = 1. When either RCLK or TCLK = 1, this bit is ignored and the timer is forced to auto-reload on Timer 2 overflow.

**Table 3a.** AUXR: Auxiliary Register

AUXR	Address = 8EH	Reset Value = XXX00X00B							
Not Bit Addressable									
		–	–	–	WDIDLE	DISRTO	–	EXTRAM	DISALE
Bit		7	6	5	4	3	2	1	0
–	Reserved for future expansion								
DISALE	Disable/Enable ALE								
	DISALE	Operating Mode							
	0	ALE is emitted at a constant rate of 1/6 the oscillator frequency							
	1	ALE is active only during a MOVX or MOVC instruction							
EXTRAM	Internal/External RAM access using MOVX @ Ri/@DPTR								
	EXTRAM	Operating Mode							
	0	Internal ERAM (00H-FFH) access using MOVX @ Ri/@DPTR							
	1	External data memory access							
DISRTO	Disable/Enable Reset out								
	DISRTO	Operating Mode							
	0	Reset pin is driven High after WDT times out							
	1	Reset pin is input only							
WDIDLE	Disable/Enable WDT in IDLE mode								
	WDIDLE	Operating Mode							
	0	WDT continues to count in IDLE mode							
	1	WDT halts counting in IDLE mode							

**Dual Data Pointer Registers:** To facilitate accessing both internal and external data memory, two banks of 16-bit Data Pointer Registers are provided: DP0 at SFR address locations 82H-83H and DP1 at 84H-85H. Bit DPS = 0 in SFR AUXR1 selects DP0 and DPS = 1 selects DP1. The user should always initialize the DPS bit to the appropriate value before accessing the respective Data Pointer Register.

**Power Off Flag:** The Power Off Flag (POF) is located at bit 4 (PCON.4) in the PCON SFR. POF is set to “1” during power up. It can be set and rest under software control and is not affected by reset.

**Table 3b.** AUXR1: Auxiliary Register 1

AUXR1	Address = A2H	Reset Value = XXXXXXX0B																
	Not Bit Addressable																	
	<table border="1" style="margin: auto; border-collapse: collapse;"> <tr> <td style="width: 20px; text-align: center;">–</td> <td style="width: 20px; text-align: center;">–</td> <td style="width: 20px; text-align: center;">–</td> <td style="width: 20px; text-align: center;">–</td> <td style="width: 20px; text-align: center;">–</td> <td style="width: 20px; text-align: center;">–</td> <td style="width: 20px; text-align: center;">–</td> <td style="width: 20px; text-align: center;">DPS</td> </tr> <tr> <td style="text-align: center;">Bit</td> <td style="text-align: center;">7</td> <td style="text-align: center;">6</td> <td style="text-align: center;">5</td> <td style="text-align: center;">4</td> <td style="text-align: center;">3</td> <td style="text-align: center;">2</td> <td style="text-align: center;">1</td> <td style="text-align: center;">0</td> </tr> </table>	–	–	–	–	–	–	–	DPS	Bit	7	6	5	4	3	2	1	0
–	–	–	–	–	–	–	DPS											
Bit	7	6	5	4	3	2	1	0										
–	Reserved for future expansion																	
DPS	Data Pointer Register Select																	
	DPS																	
	0	Selects DPTR Registers DP0L, DP0H																
	1	Selects DPTR Registers DP1L, DP1H																

## Memory Organization

MCS-51 devices have a separate address space for Program and Data Memory. Up to 64K bytes each of external Program and Data Memory can be addressed.

## Program Memory

If the  $\overline{EA}$  pin is connected to GND, all program fetches are directed to external memory. On the AT89C51RC, if  $\overline{EA}$  is connected to  $V_{CC}$ , program fetches to addresses 0000H through 7FFFH are directed to internal memory and fetches to addresses 8000H through FFFFH are to external memory.

## Data Memory

The AT89C51RC has internal data memory that is mapped into four separate segments: the lower 128 bytes of RAM, upper 128 bytes of RAM, 128 bytes special function register (SFR) and 256 bytes expanded RAM (ERAM).

The four segments are:

1. The Lower 128 bytes of RAM (addresses 00H to 7FH) are directly and indirectly addressable.
2. The Upper 128 bytes of RAM (addresses 80H to FFH) are indirectly addressable only.
3. The Special Function Registers, SFRs, (addresses 80H to FFH) are directly addressable only.
4. The 256-byte expanded RAM (ERAM, 00H-FFH) is indirectly accessed by MOVX instructions, and with the EXTRAM bit cleared.

The Lower 128 bytes can be accessed by either direct or indirect addressing. The Upper 128 bytes can be accessed by indirect addressing only. The Upper 128 bytes occupy the same address space as the SFR. This means they have the same address, but are physically separate from the SFR space.

When an instruction accesses an internal location above address 7FH, the CPU knows whether the access is to the upper 128 bytes of data RAM or to SFR space by the addressing mode used in the instruction. Instructions that use direct addressing access SFR space. For example:

```
MOV 0A0H, # data
```

accesses the SFR at location 0S0H (which is P2). Instructions that use indirect addressing access the Upper 128 bytes of data RAM. For example:

```
MOV@R0, # data
```

where R0 contains 0A0H, accesses the data byte at address 0A0H, rather than P2 (whose address is 0A0H).

Note that stack operations are examples of indirect addressing, so the upper 128 bytes of data RAM are available as stack space.

The 256 bytes of ERAM can be accessed by indirect addressing, with EXTRAM bit cleared and MOVX instructions. This part of memory is physically located on-chip, logically occupying the first 256 bytes of external data memory.

**Figure 1.** Internal and External Data Memory Address (with EXTRAM = 0)

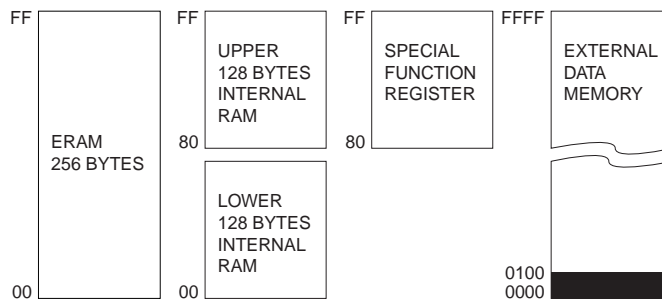

With EXTRAM = 0, the ERAM is indirectly addressed, using the MOVX instruction in combination with any of the registers R0, R1 of the selected bank or DPTR. An access to ERAM will not affect ports P0, P2, P3.6 ( $\overline{WR}$ ), and P3.7 ( $\overline{RD}$ ). For example, with EXTRAM = 0,

```
MOVX@R0, # data
```

where R0 contains 0A0H, accesses the ERAM at address 0A0H rather than external memory. An access to external data memory locations higher than FFH (i.e. 0100H to FFFFH) will be performed with the MOVX DPTR instructions in the same way as in the standard 80C51, i.e., with P0 and P2 as data/address bus, and P3.6 and P3.7 as write and read timing signals. Refer to Figure 1.

With EXTRAM = 1, MOVX @ Ri and MOVX@DPTR will be similar to the standard 80C51. MOVX@Ri will provide an 8-bit address multiplexed with data on Port 0 and any output port pins can be used to output higher-order address bits. This is to provide the external paging capability. MOVX@DPTR will generate a 16-bit address. Port 2 outputs the high-order 8 address bits (the contents of DP0H), while Port 0 multiplexes the low-order 8 address bits (the contents of DP0L) with data. MOVX@Ri and MOVX@DPTR will generate either read or write signals on P3.6 ( $\overline{WR}$ ) and P3.7 ( $\overline{RD}$ ).

The stack pointer (SP) may be located anywhere in the 256 bytes RAM (lower and upper RAM) internal data memory. The stack may not be located in the ERAM.

## Hardware Watchdog Timer (One-time Enabled with Reset-out)

The WDT is intended as a recovery method in situations where the CPU may be subjected to software upsets. The WDT consists of a 13-bit counter and the WatchDog Timer Reset (WDTRST) SFR. The WDT is defaulted to disable from exiting reset. To enable the WDT, a user must write 01EH and 0E1H in sequence to the WDTRST register (SFR location 0A6H). When the WDT is enabled, it will increment every machine cycle while the oscillator is running. The WDT timeout period is dependent on the external clock frequency. There is no way to disable the WDT except through reset (either hardware reset or WDT overflow reset). When WDT overflows, it will drive an output RESET HIGH pulse at the RST pin.

## Using the WDT

To enable the WDT, a user must write 01EH and 0E1H in sequence to the WDTRST register (SFR location 0A6H). When the WDT is enabled, the user needs to service it by writing 01EH and 0E1H to WDTRST to avoid a WDT overflow. The 13-bit counter overflows when it reaches 8191 (1FFFH), and this will reset the device. When the WDT is enabled, it will increment every machine cycle while the oscillator is running. This means the user must reset the WDT at least every 8191 machine cycles. To reset the WDT the user must write 01EH and 0E1H to WDTRST. WDTRST is a write-only register. The WDT counter cannot be read or written. When WDT overflows, it will generate an output RESET pulse at the RST pin. The RESET pulse duration is  $98 \times T_{OSC}$ , where  $T_{OSC} = 1/F_{OSC}$ . To make the best use of the WDT, it should be serviced in those sections of code that will periodically be executed within the time required to prevent a WDT reset.

## WDT During Power-down and Idle

In Power-down mode the oscillator stops, which means the WDT also stops. While in Power-down mode, the user does not need to service the WDT. There are two methods of exiting Power-down mode: by a hardware reset or via a level-activated external interrupt which is enabled prior to entering Power-down mode. When Power-down is exited with hardware reset, servicing the WDT should occur as it normally does whenever the AT89C51RC is reset. Exiting Power-down with an interrupt is significantly different. The interrupt is held low long enough for the oscillator to stabilize. When the interrupt is brought high, the interrupt is serviced. To prevent the WDT from resetting the device while the interrupt pin is held low, the WDT is not started until the interrupt is pulled high. It is suggested that the WDT be reset during the interrupt service for the interrupt used to exit Power-down mode.

To ensure that the WDT does not overflow within a few states of exiting Power-down, it is best to reset the WDT just before entering Power-down mode.

Before going into the IDLE mode, the WDIDLE bit in SFR AUXR is used to determine whether the WDT continues to count if enabled. The WDT keeps counting during IDLE (WDIDLE bit = 0) as the default state. To prevent the WDT from resetting the AT89C51RC while in IDLE mode, the user should always set up a timer that will periodically exit IDLE, service the WDT, and reenter IDLE mode.

With WDIDLE bit enabled, the WDT will stop to count in IDLE mode and resumes the count upon exit from IDLE.

## UART

The UART in the AT89C51RC operates the same way as the UART in the AT89C51 and AT89C52. For further information, see the December 1997 Microcontroller Data Book, page 2-48, section titled, "Serial Interface".

## Timer 0 and 1

Timer 0 and Timer 1 in the AT89C51RC operate the same way as Timer 0 and Timer 1 in the AT89C51 and AT89C52.

## Timer 2

Timer 2 is a 16-bit Timer/Counter that can operate as either a timer or an event counter. The type of operation is selected by bit  $\overline{C/T2}$  in the SFR T2CON (shown in Table 2). Timer 2 has three operating modes: capture, auto-reload (up or down counting), and baud rate generator. The modes are selected by bits in T2CON, as shown in Table 3.

Timer 2 consists of two 8-bit registers, TH2 and TL2. In the Timer function, the TL2 register is incremented every machine cycle. Since a machine cycle consists of 12 oscillator periods, the count rate is 1/12 of the oscillator frequency.

**Table 3.** Timer 2 Operating Modes

RCLK +TCLK	CP/RL2	TR2	MODE
0	0	1	16-bit Auto-reload
0	1	1	16-bit Capture
1	X	1	Baud Rate Generator
X	X	0	(Off)

In the Counter function, the register is incremented in response to a 1-to-0 transition at its corresponding external input pin, T2. In this function, the external input is sampled during S5P2 of every machine cycle. When the samples show a high in one cycle and a low in the next cycle, the count is incremented. The new count value appears in the register during S3P1 of the cycle following the one in which the transition was detected. Since two machine cycles (24 oscillator periods) are required to recognize a 1-to-0 transition, the maximum count rate is 1/24 of the oscillator frequency. To ensure that a given level is sampled at least once before it changes, the level should be held for at least one full machine cycle.

### Capture Mode

In the capture mode, two options are selected by bit EXEN2 in T2CON. If EXEN2 = 0, Timer 2 is a 16-bit timer or counter which upon overflow sets bit TF2 in T2CON. This bit can then be used to generate an interrupt. If EXEN2 = 1, Timer 2 performs the same operation, but a 1-to-0 transition at external input T2EX also causes the current value in TH2 and TL2 to be captured into RCAP2H and RCAP2L, respectively. In addition, the transition at T2EX causes bit EXF2 in T2CON to be set. The EXF2 bit, like TF2, can generate an interrupt. The capture mode is illustrated in Figure 2.

### Auto-Reload (Up or Down Counter)

Timer 2 can be programmed to count up or down when configured in its 16-bit auto-reload mode. This feature is invoked by the DCEN (Down Counter Enable) bit located in the SFR T2MOD (see Table 4). Upon reset, the DCEN bit is set to 0 so that timer 2 will default to count up. When DCEN is set, Timer 2 can count up or down, depending on the value of the T2EX pin.

Figure 2. Timer in Capture Mode

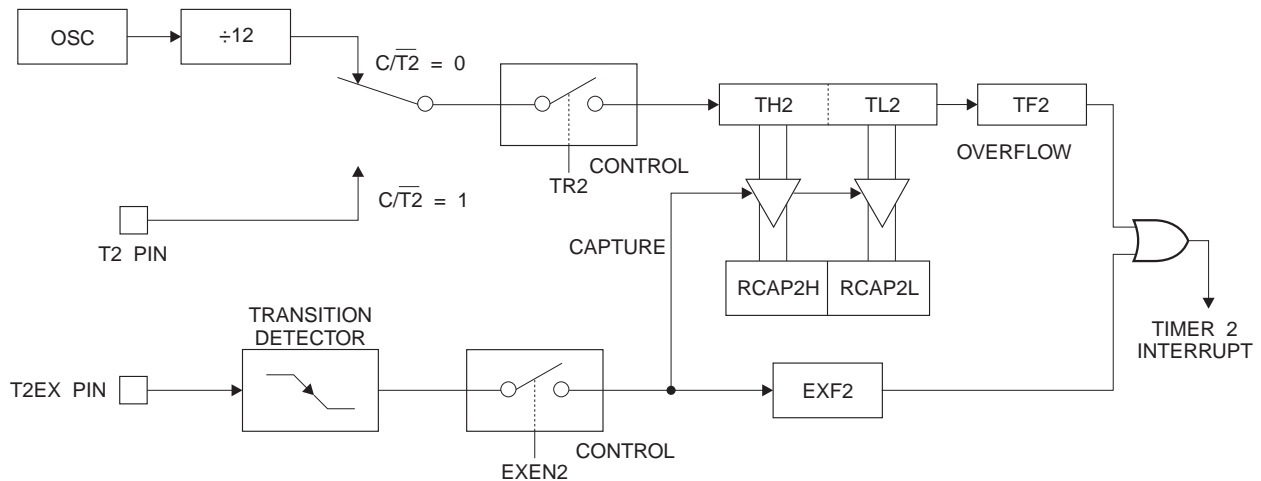

Figure 3 shows Timer 2 automatically counting up when DCEN=0. In this mode, two options are selected by bit EXEN2 in T2CON. If EXEN2 = 0, Timer 2 counts up to 0FFFFH and then sets the TF2 bit upon overflow. The overflow also causes the timer registers to be reloaded with the 16-bit value in RCAP2H and RCAP2L. The values in Timer in Capture Mode RCAP2H and RCAP2L are preset by software. If EXEN2 = 1, a 16-bit reload can be triggered either by an overflow or by a 1-to-0 transition at external input T2EX. This transition also sets the EXF2 bit. Both the TF2 and EXF2 bits can generate an interrupt if enabled.

Setting the DCEN bit enables Timer 2 to count up or down, as shown in Figure 3. In this mode, the T2EX pin controls the direction of the count. A logic 1 at T2EX makes Timer 2 count up. The timer will overflow at 0FFFFH and set the TF2 bit. This overflow also causes the 16-bit value in RCAP2H and RCAP2L to be reloaded into the timer registers, TH2 and TL2, respectively.

A logic 0 at T2EX makes Timer 2 count down. The timer underflows when TH2 and TL2 equal the values stored in RCAP2H and RCAP2L. The underflow sets the TF2 bit and causes 0FFFFH to be reloaded into the timer registers.

The EXF2 bit toggles whenever Timer 2 overflows or underflows and can be used as a 17th bit of resolution. In this operating mode, EXF2 does not flag an interrupt.

**Figure 3.** Timer 2 Auto Reload Mode (DCEN = 0)

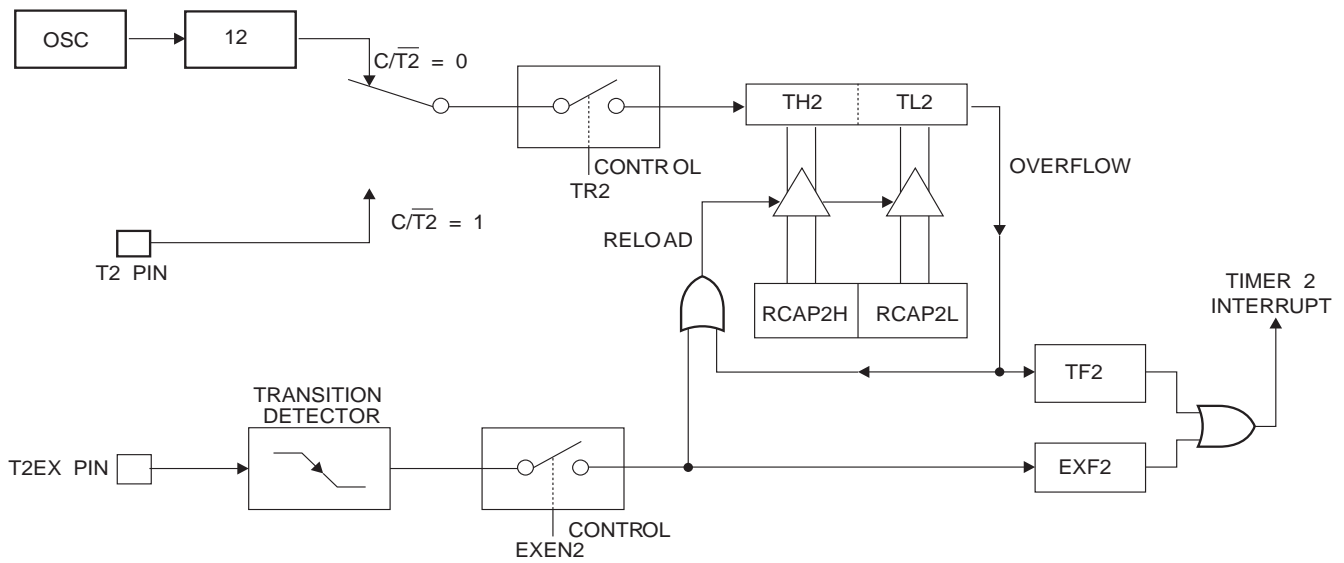

**Table 4.** T2MOD—Timer 2 Mode Control Register

T2MOD Address = 0C9H						Reset Value = XXXX XX00B		
Not Bit Addressable								
	-	-	-	-	-	-	T2OE	DCEN
Bit	7	6	5	4	3	2	1	0

Symbol	Function
-	Not implemented, reserved for future
T2OE	Timer 2 Output Enable bit
DCEN	When set, this bit allows Timer 2 to be configured as an up/down counter

Figure 4. Timer 2 Auto Reload Mode (DCEN = 1)

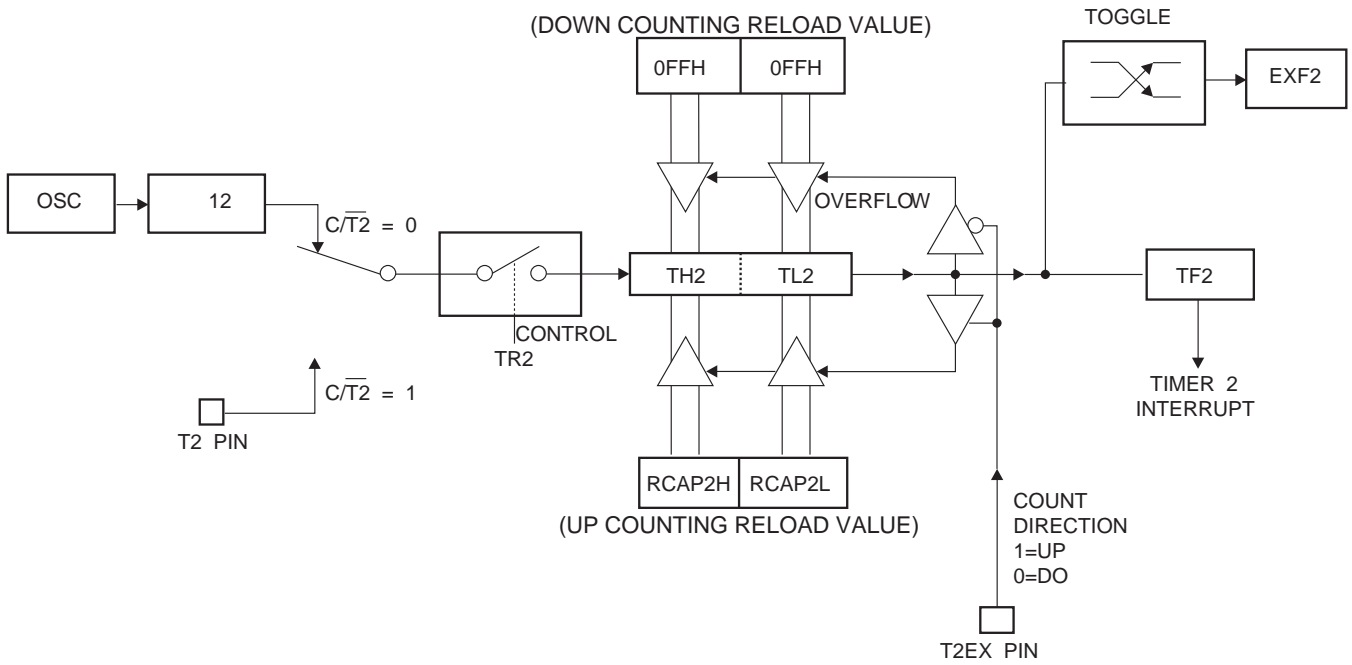
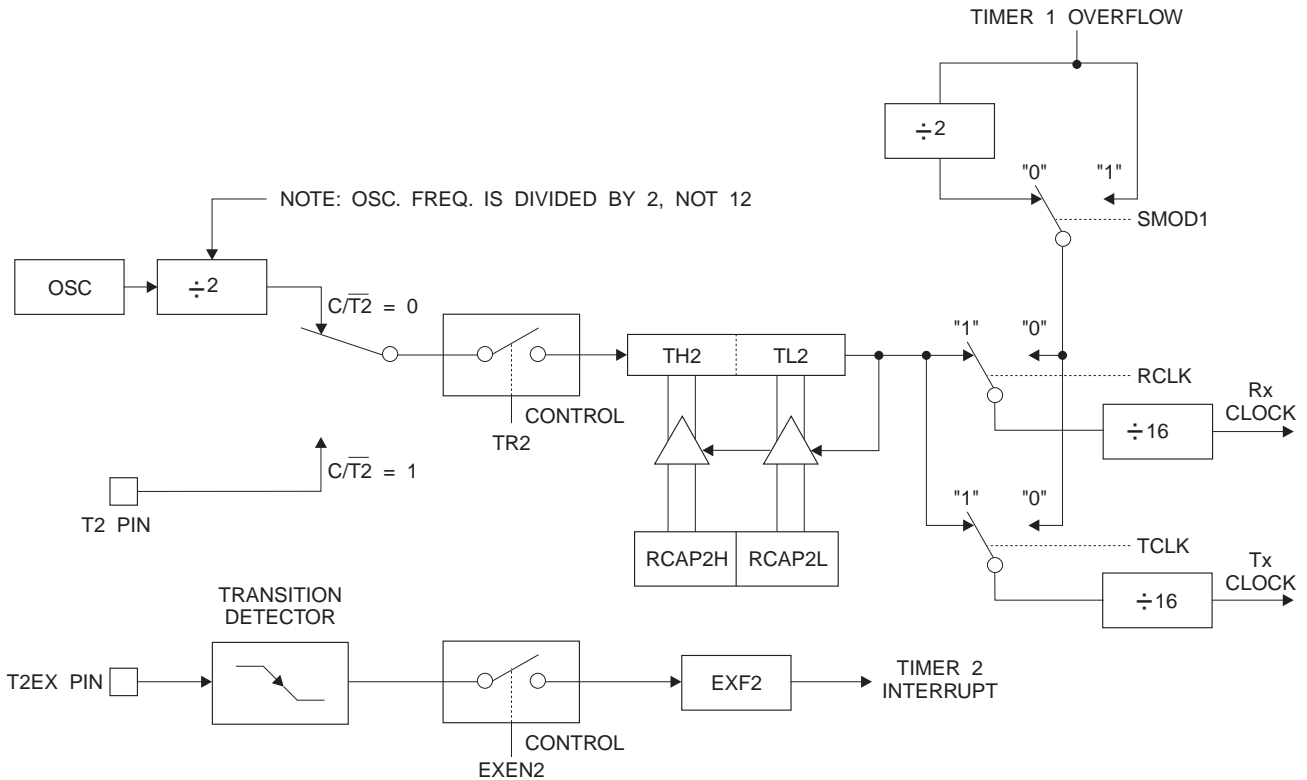

Figure 5. Timer 2 in Baud Rate Generator Mode





## Baud Rate Generator

Timer 2 is selected as the baud rate generator by setting TCLK and/or RCLK in T2CON (Table 2). Note that the baud rates for transmit and receive can be different if Timer 2 is used for the receiver or transmitter and Timer 1 is used for the other function. Setting RCLK and/or TCLK puts Timer 2 into its baud rate generator mode, as shown in Figure 5.

The baud rate generator mode is similar to the auto-reload mode, in that a rollover in TH2 causes the Timer 2 registers to be reloaded with the 16-bit value in registers RCAP2H and RCAP2L, which are preset by software.

The baud rates in Modes 1 and 3 are determined by Timer 2's overflow rate according to the following equation.

$$\text{Modes 1 and 3 Baud Rates} = \frac{\text{Timer 2 Overflow Rate}}{16}$$

The Timer can be configured for either timer or counter operation. In most applications, it is configured for timer operation ( $CP/\overline{T2} = 0$ ). The timer operation is different for Timer 2 when it is used as a baud rate generator. Normally, as a timer, it increments every machine cycle (at 1/12 the oscillator frequency). As a baud rate generator, however, it increments every state time (at 1/2 the oscillator frequency). The baud rate formula is given below.

$$\frac{\text{Modes 1 and 3}}{\text{Baud Rate}} = \frac{\text{Oscillator Frequency}}{32 \times [65536 - \text{RCAP2H}, \text{RCAP2L}]}$$

where (RCAP2H, RCAP2L) is the content of RCAP2H and RCAP2L taken as a 16-bit unsigned integer.

Timer 2 as a baud rate generator is shown in Figure 5. This figure is valid only if RCLK or TCLK = 1 in T2CON. Note that a rollover in TH2 does not set TF2 and will not generate an interrupt. Note too, that if EXEN2 is set, a 1-to-0 transition in T2EX will set EXF2 but will not cause a reload from (RCAP2H, RCAP2L) to (TH2, TL2). Thus when Timer 2 is in use as a baud rate generator, T2EX can be used as an extra external interrupt.

Note that when Timer 2 is running (TR2 = 1) as a timer in the baud rate generator mode, TH2 or TL2 should not be read from or written to. Under these conditions, the Timer is incremented every state time, and the results of a read or write may not be accurate. The RCAP2 registers may be read but should not be written to, because a write might overlap a reload and cause write and/or reload errors. The timer should be turned off (clear TR2) before accessing the Timer 2 or RCAP2 registers.

Figure 6. Timer 2 in Clock-Out Mode

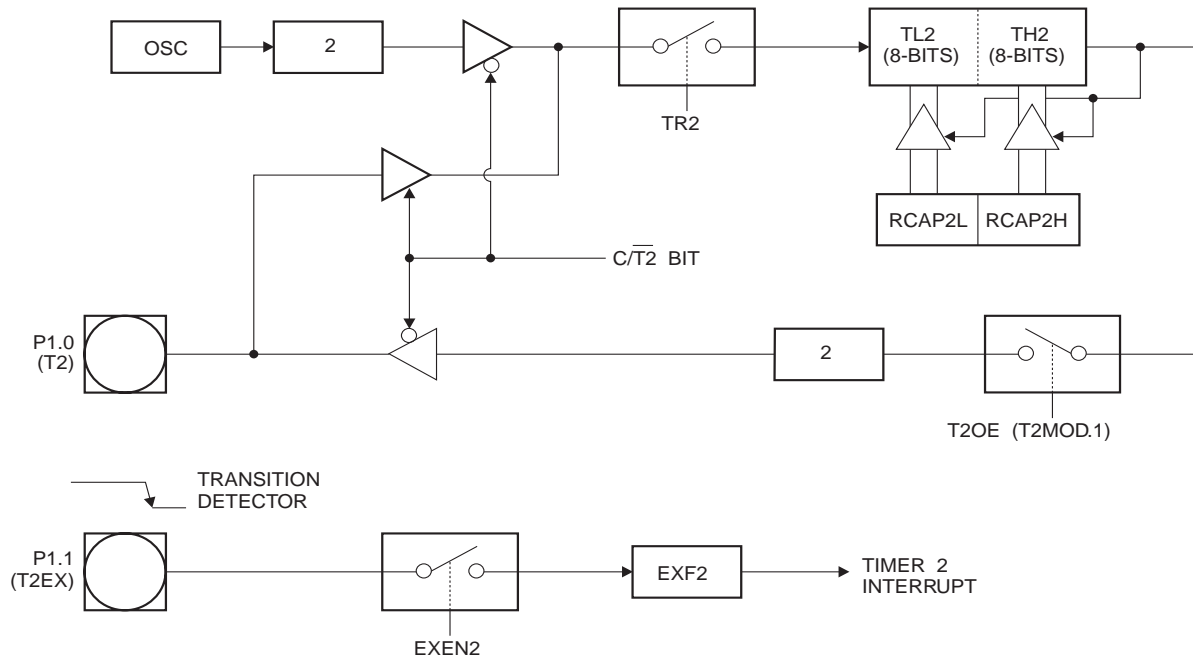

## Programmable Clock Out

A 50% duty cycle clock can be programmed to come out on P1.0, as shown in Figure 6. This pin, besides being a regular I/O pin, has two alternate functions. It can be programmed to input the external clock for Timer/Counter 2 or to output a 50% duty cycle clock ranging from 61 Hz to 4 MHz at a 16 MHz operating frequency.

To configure the Timer/Counter 2 as a clock generator, bit  $C/\overline{T2}$  (T2CON.1) must be cleared and bit T2OE (T2MOD.1) must be set. Bit TR2 (T2CON.2) starts and stops the timer.

The clock-out frequency depends on the oscillator frequency and the reload value of Timer 2 capture registers (RCAP2H, RCAP2L), as shown in the following equation.

$$\text{Clock-Out Frequency} = \frac{\text{Oscillator Frequency}}{4 \times [65536 - (\text{RCAP2H}, \text{RCAP2L})]}$$

In the clock-out mode, Timer 2 roll-overs will not generate an interrupt. This behavior is similar to when Timer 2 is used as a baud-rate generator. It is possible to use Timer 2 as a baud-rate generator and a clock generator simultaneously. Note, however, that the baud-rate and clock-out frequencies cannot be determined independently from one another since they both use RCAP2H and RCAP2L.

## Interrupts

The AT89C51RC has a total of six interrupt vectors: two external interrupts ( $\overline{\text{INT0}}$  and  $\overline{\text{INT1}}$ ), three timer interrupts (Timers 0, 1, and 2), and the serial port interrupt. These interrupts are all shown in Figure 7.

Each of these interrupt sources can be individually enabled or disabled by setting or clearing a bit in Special Function Register IE. IE also contains a global disable bit, EA, which disables all interrupts at once.

Note that Table 5 shows that bit position IE.6 is unimplemented. User software should not write 1s to these bit positions, since they may be used in future AT89 products.

Timer 2 interrupt is generated by the logical OR of bits TF2 and EXF2 in register T2CON. Neither of these flags is cleared by hardware when the service routine is vectored to. In fact, the service routine may have to determine whether it was TF2 or EXF2 that generated the interrupt, and that bit will have to be cleared in software.

The Timer 0 and Timer 1 flags, TF0 and TF1, are set at S5P2 of the cycle in which the timers overflow. The values are then polled by the circuitry in the next cycle. However, the Timer 2 flag, TF2, is set at S2P2 and is polled in the same cycle in which the timer overflows.

**Table 5.** Interrupt Enable (IE) Register

(MSB)				(LSB)			
EA	–	ET2	ES	ET1	EX1	ET0	EX0

Enable Bit = 1 enables the interrupt.  
 Enable Bit = 0 disables the interrupt.

Symbol	Position	Function
EA	IE.7	Disables all interrupts. If EA = 0, no interrupt is acknowledged. If EA = 1, each interrupt source is individually enabled or disabled by setting or clearing its enable bit.
–	IE.6	Reserved.
ET2	IE.5	Timer 2 interrupt enable bit.
ES	IE.4	Serial Port interrupt enable bit.
ET1	IE.3	Timer 1 interrupt enable bit.
EX1	IE.2	External interrupt 1 enable bit.
ET0	IE.1	Timer 0 interrupt enable bit.
EX0	IE.0	External interrupt 0 enable bit.

User software should never write 1s to reserved bits, because they may be used in future AT89 products.

**Figure 7.** Interrupt Sources

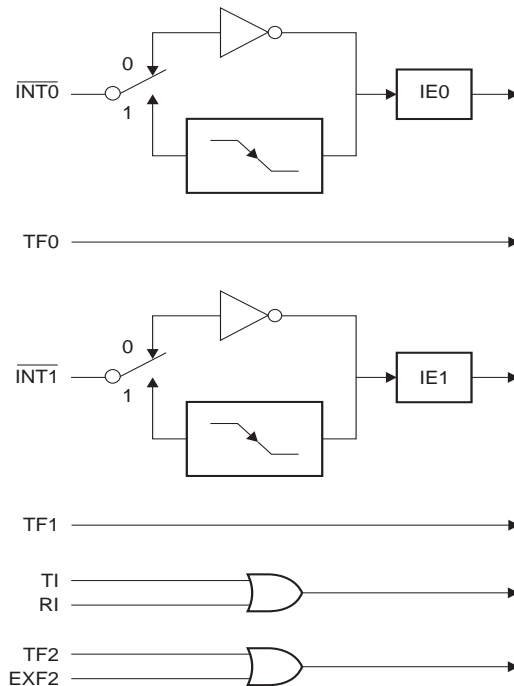

## Oscillator Characteristics

XTAL1 and XTAL2 are the input and output, respectively, of an inverting amplifier that can be configured for use as an on-chip oscillator, as shown in Figure 8. Either a quartz crystal or ceramic resonator may be used. To drive the device from an external clock source, XTAL2 should be left unconnected while XTAL1 is driven, as shown in Figure 9. There are no requirements on the duty cycle of the external clock signal, since the input to the internal clocking circuitry is through a divide-by-two flip-flop, but minimum and maximum voltage high and low time specifications must be observed.

## Idle Mode

In idle mode, the CPU puts itself to sleep while all the on-chip peripherals remain active. The mode is invoked by software. The content of the on-chip RAM and all the special functions registers remain unchanged during this mode. The idle mode can be terminated by any enabled interrupt or by a hardware reset.

Note that when idle mode is terminated by a hardware reset, the device normally resumes program execution from where it left off, up to two machine cycles before the internal reset algorithm takes control. On-chip hardware inhibits access to internal RAM in this event, but access to the port pins is not inhibited. To eliminate the possibility of an unexpected write to a port pin when idle mode is terminated by a reset, the instruction following the one that invokes idle mode should not write to a port pin or to external memory.

## Power-down Mode

In the Power-down mode, the oscillator is stopped, and the instruction that invokes Power-down is the last instruction executed. The on-chip RAM and Special Function Registers retain their values until the Power-down mode is terminated. Exit from Power-down can be initiated either by a hardware reset or by an enabled external interrupt. Reset redefines the SFRs but does not change the on-chip RAM. The reset should not be activated before  $V_{CC}$  is restored to its normal operating level and must be held active long enough to allow the oscillator to restart and stabilize.

**Figure 8.** Oscillator Connections

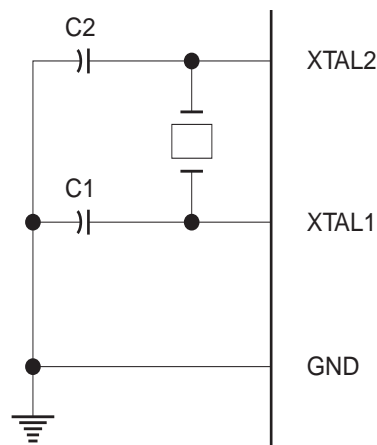

Note: C1, C2 = 30 pF ± 10 pF for Crystals  
 = 40 pF ± 10 pF for Ceramic Resonators

**Figure 9.** External Clock Drive Configuration

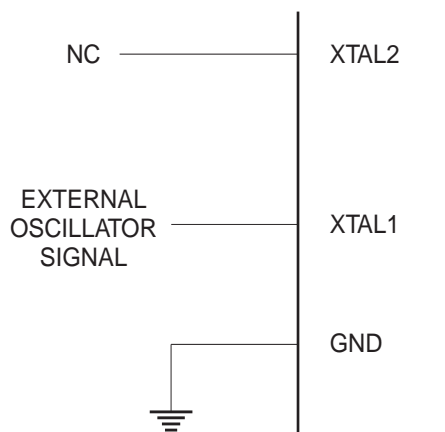

**Table 6.** Status of External Pins During Idle and Power-down Modes

Mode	Program Memory	ALE	$\overline{\text{PSEN}}$	PORT0	PORT1	PORT2	PORT3
Idle	Internal	1	1	Data	Data	Data	Data
Idle	External	1	1	Float	Data	Address	Data
Power-down	Internal	0	0	Data	Data	Data	Data
Power-down	External	0	0	Float	Data	Data	Data

## Program Memory Lock Bits

The AT89C51RC has three lock bits that can be left unprogrammed (U) or can be programmed (P) to obtain the additional features listed in the following table.

**Table 7.** Lock Bit Protection Modes

Program Lock Bits				Protection Type
	LB1	LB2	LB3	
1	U	U	U	No program lock features
2	P	U	U	MOV <sub>C</sub> instructions executed from external program memory are disabled from fetching code bytes from internal memory, $\overline{\text{EA}}$ is sampled and latched on reset, and further programming of the Flash memory is disabled
3	P	P	U	Same as mode 2, but verify is also disabled
4	P	P	P	Same as mode 3, but external execution is also disabled

When lock bit 1 is programmed, the logic level at the  $\overline{\text{EA}}$  pin is sampled and latched during reset. If the device is powered up without a reset, the latch initializes to a random value and holds that value until reset is activated. The latched value of  $\overline{\text{EA}}$  must agree with the current logic level at that pin in order for the device to function properly.

## Programming the Flash

The AT89C51RC is shipped with the on-chip Flash memory array ready to be programmed. The programming interface needs a high-voltage (12-volt) program enable signal and is compatible with conventional third-party Flash or EPROM programmers.

The AT89C51RC code memory array is programmed byte-by-byte.

**Programming Algorithm:** Before programming the AT89C51RC, the address, data, and control signals should be set up according to the Flash programming mode table and Figures 10 and 11. To program the AT89C51RC, take the following steps:

1. Input the desired memory location on the address lines.
2. Input the appropriate data byte on the data lines.
3. Activate the correct combination of control signals.
4. Raise  $\overline{EA}/V_{PP}$  to 12V.
5. Pulse  $ALE/\overline{PROG}$  once to program a byte in the Flash array or the lock bits. The byte-write cycle is self-timed and typically takes no more than 50  $\mu$ s. Repeat steps 1 through 5, changing the address and data for the entire array or until the end of the object file is reached.

**Chip Erase Sequence:** Before the AT89C51RC can be reprogrammed, a Chip Erase operation needs to be performed. To erase the contents of the AT89C51RC, follow this sequence:

1. Raise  $V_{CC}$  to 6.5V.
2. Pulse  $ALE/\overline{PROG}$  once (duration of 200 ns - 500 ns) and wait for 150 ms.
3. Power  $V_{CC}$  down and up to 6.5V.
4. Pulse  $ALE/\overline{PROG}$  once (duration of 200 ns - 500 ns) and wait for 150 ms.
5. Power  $V_{CC}$  down and up.

**Data Polling:** The AT89C51RC features  $\overline{Data}$  Polling to indicate the end of a write cycle. During a write cycle, an attempted read of the last byte written will result in the complement of the written data on P0.7. Once the write cycle has been completed, true data is valid on all outputs, and the next cycle may begin.  $\overline{Data}$  Polling may begin any time after a write cycle has been initiated.

**Ready/Busy:** The progress of byte programming can also be monitored by the  $RDY/\overline{BSY}$  output signal. P3.0 is pulled low after  $ALE$  goes high during programming to indicate  $\overline{BUSY}$ . P3.0 is pulled high again when programming is done to indicate  $READY$ .

**Program Verify:** If lock bits LB1 and LB2 have not been programmed, the programmed code data can be read back via the address and data lines for verification. The status of the individual lock bits can be verified directly by reading them back.

**Reading the Signature Bytes:** The signature bytes are read by the same procedure as a normal verification of locations 000H, 100H, and 200H, except that P3.6 and P3.7 must be pulled to a logic low. The values returned are as follows:





- (000H) = 1EH indicates manufactured by Atmel
- (100H) = 51H
- (200H) = 07H indicates 89C51RC

## Programming Interface

Every code byte in the Flash array can be programmed by using the appropriate combination of control signals. The write operation cycle is self-timed and once initiated, will automatically time itself to completion.

Most major worldwide programming vendors offer support for the Atmel microcontroller series. Please contact your local programming vendor for the appropriate software revision.

**Table 8. Flash Programming Modes**

Mode	V <sub>CC</sub>	RST	PSEN	ALE/ PROG	EA/ V <sub>PP</sub>	P2.6	P2.7	P3.3	P3.6	P3.7	P0.7-0 Data	P3.4	P2.5-0	P1.7-0
												Address		
Write Code Data	5V	H	L		12 V	L	H	H	H	H	D <sub>IN</sub>	A14	A13-8	A7-0
Read Code Data	5V	H	L	H	H/12 V	L	L	L	H	H	D <sub>OUT</sub>	A14	A13-8	A7-0
Write Lock Bit 1	6.5V	H	L		12 V	H	H	H	H	H	X	X	X	X
Write Lock Bit 2	6.5V	H	L		12 V	H	H	H	L	L	X	X	X	X
Write Lock Bit 3	6.5V	H	L		12 V	H	L	H	H	L	X	X	X	X
Read Lock Bits 1, 2, 3	5V	H	L	H	H	H	H	L	H	L	P0.2, P0.3, P0.4	X	X	X
Chip Erase	6.5V	H	L		12V	H	L	H	L	L	X	X	X	X
Read Atmel ID	5V	H	L	H	H	L	L	L	L	L	1EH	X	XX 0000	00H
Read Device ID	5V	H	L	H	H	L	L	L	L	L	51H	X	XX 0001	00H
Read Device ID	5V	H	L	H	H	L	L	L	L	L	07H	X	XX 0010	00H

- Notes:
1. Write Code Data requires a 200 ns PROG pulse.
  2. Write Lock Bits requires a 100 μs PROG pulse.
  3. Chip Erase requires a 200 ns - 500 ns PROG pulse.
  4. RDY/BSY signal is output on P3.0 during programming.



**Figure 10.** Programming the Flash Memory

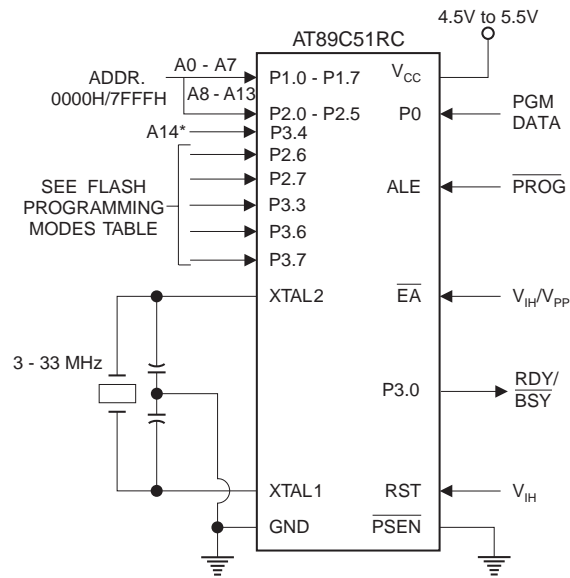

**Figure 11.** Verifying the Flash Memory

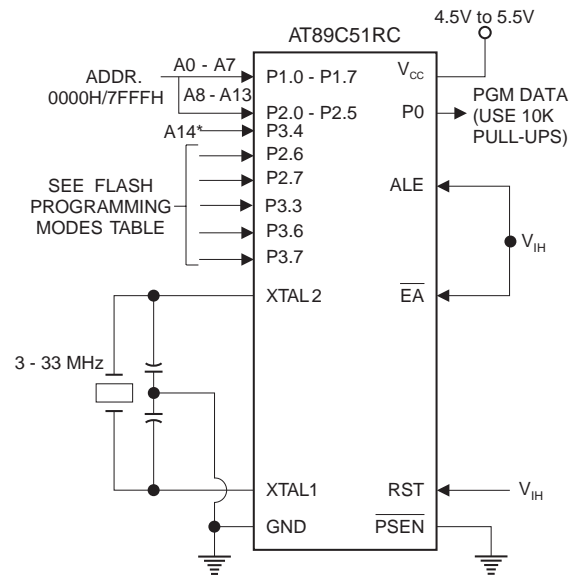

Note: \*Programming address line A14 (P3.4) is not the same as the external memory address line A14 (P2.6).

## Flash Programming and Verification Characteristics

$T_A = 20^\circ\text{C}$  to  $30^\circ\text{C}$ ,  $V_{CC} = 4.5\text{V}$  to  $5.5\text{V}$

Symbol	Parameter	Min	Max	Units
$V_{PP}$	Programming Supply Voltage	11.5	12.5	V
$I_{PP}$	Programming Supply Current		10	mA
$I_{CC}$	$V_{CC}$ Supply Current		30	mA
$1/t_{CLCL}$	Oscillator Frequency	3	33	MHz
$t_{AVGL}$	Address Setup to $\overline{PROG}$ Low	$48t_{CLCL}$		
$t_{GHAX}$	Address Hold after $\overline{PROG}$	$48t_{CLCL}$		
$t_{DVGL}$	Data Setup to $\overline{PROG}$ Low	$48t_{CLCL}$		
$t_{GHDX}$	Data Hold after $\overline{PROG}$	$48t_{CLCL}$		
$t_{EHSB}$	P2.7 ( $\overline{ENABLE}$ ) High to $V_{PP}$	$48t_{CLCL}$		
$t_{SHGL}$	$V_{PP}$ Setup to $\overline{PROG}$ Low	10		$\mu\text{s}$
$t_{GHSL}$	$V_{PP}$ Hold after $\overline{PROG}$	10		$\mu\text{s}$
$t_{GLGH}$	$\overline{PROG}$ Width	0.2	1	$\mu\text{s}$
$t_{AVQV}$	Address to Data Valid		$48t_{CLCL}$	
$t_{ELQV}$	$\overline{ENABLE}$ Low to Data Valid		$48t_{CLCL}$	
$t_{EHQZ}$	Data Float after $\overline{ENABLE}$	0	$48t_{CLCL}$	
$t_{GHBL}$	$\overline{PROG}$ High to $\overline{BUSY}$ Low		1.0	$\mu\text{s}$
$t_{WC}$	Byte Write Cycle Time		80	$\mu\text{s}$

## Flash Programming and Verification Waveforms

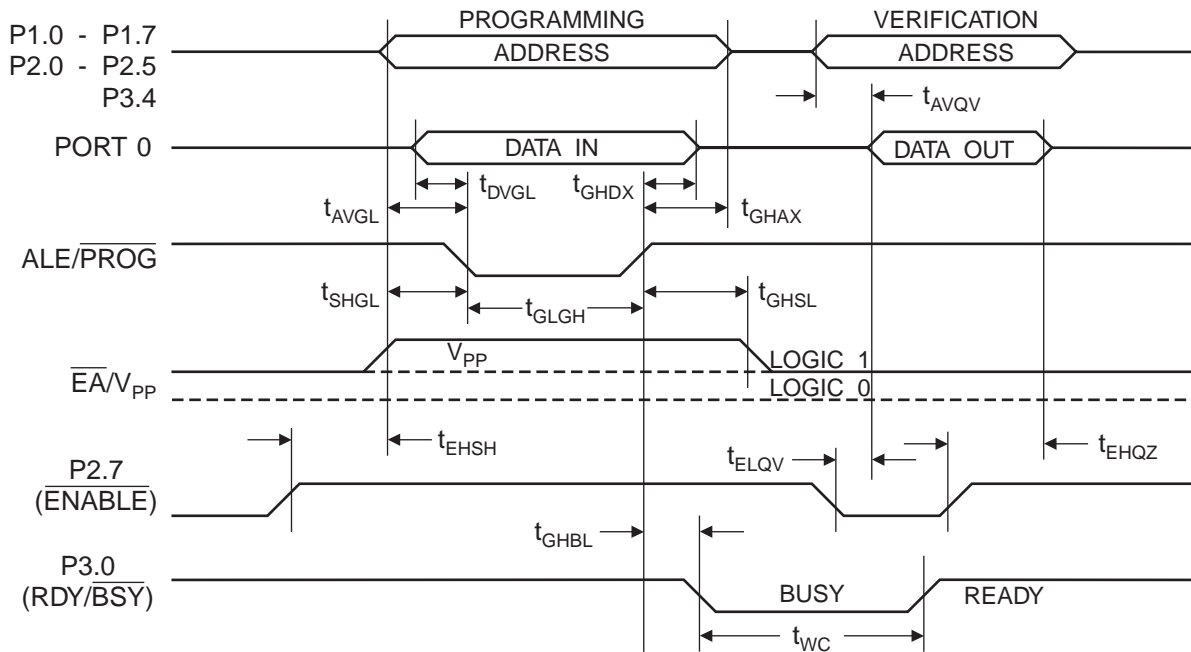

## Lock Bit Programming

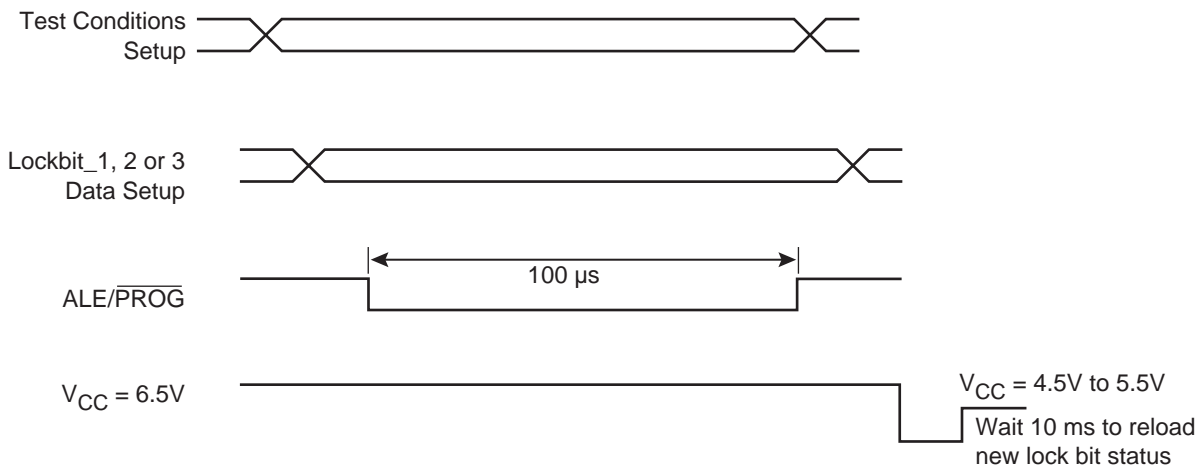

### Parallel Chip Erase Mode

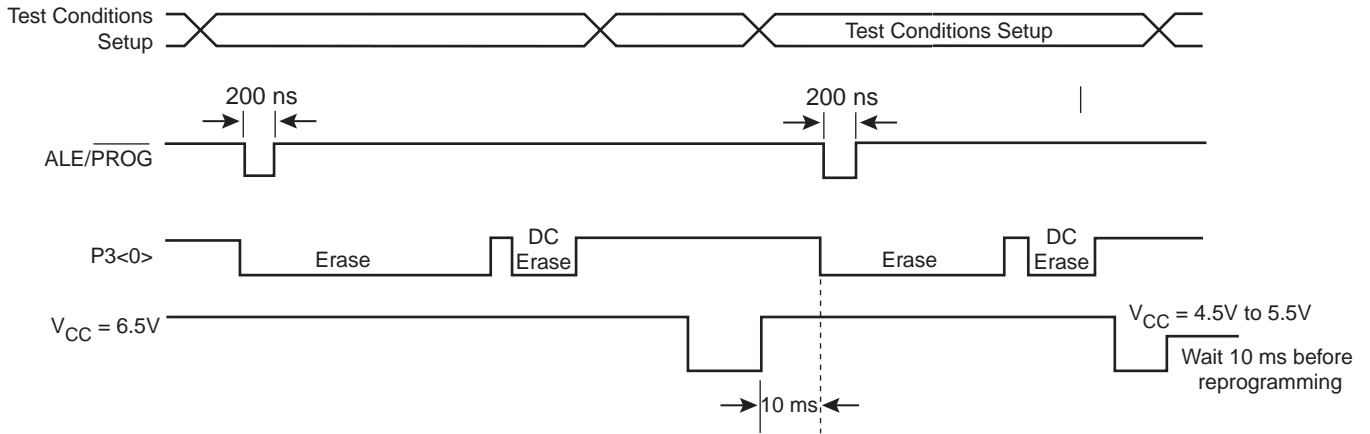



## Absolute Maximum Ratings\*

Operating Temperature.....	-55°C to +125°C
Storage Temperature .....	-65°C to +150°C
Voltage on Any Pin with Respect to Ground .....	-1.0V to +7.0V
Maximum Operating Voltage .....	6.6V
DC Output Current.....	15.0 mA

Notice\*: Stresses beyond those listed under “Absolute Maximum Ratings” may cause permanent damage to the device. This is a stress rating only and functional operation of the device at these or any other conditions beyond those indicated in the operational sections of this specification is not implied. Exposure to absolute maximum rating conditions for extended periods may affect device reliability.

## DC Characteristics

The values shown in this table are valid for  $T_A = -40^\circ\text{C}$  to  $85^\circ\text{C}$  and  $V_{CC} = 4.0\text{V}$  to  $5.5\text{V}$ , unless otherwise noted.

Symbol	Parameter	Condition	Min	Max	Units
$V_{IL}$	Input Low-voltage	(Except $\overline{EA}$ )	-0.5	$0.2 V_{CC}-0.1$	V
$V_{IL1}$	Input Low-voltage ( $\overline{EA}$ )		-0.5	$0.2 V_{CC}-0.3$	V
$V_{IH}$	Input High-voltage	(Except XTAL1, RST)	$0.2 V_{CC}+0.9$	$V_{CC}+0.5$	V
$V_{IH1}$	Input High-voltage	(XTAL1, RST)	$0.7 V_{CC}$	$V_{CC}+0.5$	V
$V_{OL}$	Output Low-voltage <sup>(1)</sup> (Ports 1,2,3)	$I_{OL} = 1.6 \text{ mA}$		0.45	V
$V_{OL1}$	Output Low-voltage <sup>(1)</sup> (Port 0, ALE, $\overline{PSEN}$ )	$I_{OL} = 3.2 \text{ mA}$		0.45	V
$V_{OH}$	Output High-voltage (Ports 1,2,3, ALE, $\overline{PSEN}$ )	$I_{OH} = -60 \mu\text{A}$ , $V_{CC} = 5\text{V} \pm 10\%$	2.4		V
		$I_{OH} = -25 \mu\text{A}$	$0.75 V_{CC}$		V
		$I_{OH} = -10 \mu\text{A}$	$0.9 V_{CC}$		V
$V_{OH1}$	Output High-voltage (Port 0 in External Bus Mode)	$I_{OH} = -800 \mu\text{A}$ , $V_{CC} = 5\text{V} \pm 10\%$	2.4		V
		$I_{OH} = -300 \mu\text{A}$	$0.75 V_{CC}$		V
		$I_{OH} = -80 \mu\text{A}$	$0.9 V_{CC}$		V
$I_{IL}$	Logical 0 Input Current (Ports 1,2,3)	$V_{IN} = 0.45\text{V}$		-50	$\mu\text{A}$
$I_{TL}$	Logical 1 to 0 Transition Current (Ports 1,2,3)	$V_{IN} = 2\text{V}$ , $V_{CC} = 5\text{V} \pm 10\%$		-650	$\mu\text{A}$
$I_{LI}$	Input Leakage Current (Port 0, $\overline{EA}$ )	$0.45 < V_{IN} < V_{CC}$		$\pm 10$	$\mu\text{A}$
RRST	Reset Pull-down Resistor		10	30	$\text{k}\Omega$
$C_{IO}$	Pin Capacitance	Test Freq. = 1 MHz, $T_A = 25^\circ\text{C}$		10	pF
$I_{CC}$	Power Supply Current	Active Mode, 12 MHz		25	mA
		Idle Mode, 12 MHz		6.5	mA
	Power-down Mode <sup>(1)</sup>	$V_{CC} = 5.5\text{V}$		100	$\mu\text{A}$

Notes: 1. Under steady state (non-transient) conditions,  $I_{OL}$  must be externally limited as follows:

Maximum  $I_{OL}$  per port pin: 10 mA

Maximum  $I_{OL}$  per 8-bit port:

Port 0: 26 mA      Ports 1, 2, 3: 15 mA

Maximum total  $I_{OL}$  for all output pins: 71 mA

If  $I_{OL}$  exceeds the test condition,  $V_{OL}$  may exceed the related specification. Pins are not guaranteed to sink current greater than the listed test conditions.

2. Minimum  $V_{CC}$  for Power-down is 2V.

## AC Characteristics

Under operating conditions, load capacitance for Port 0, ALE/ $\overline{\text{PROG}}$ , and  $\overline{\text{PSEN}}$  = 100 pF; load capacitance for all other outputs = 80 pF.

## External Program and Data Memory Characteristics

Symbol	Parameter	12 MHz Oscillator		Variable Oscillator		Units
		Min	Max	Min	Max	
$1/t_{\text{CLCL}}$	Oscillator Frequency			0	33	MHz
$t_{\text{LHLL}}$	ALE Pulse Width	127		$2t_{\text{CLCL}}-40$		ns
$t_{\text{AVLL}}$	Address Valid to ALE Low	43		$t_{\text{CLCL}}-25$		ns
$t_{\text{LLAX}}$	Address Hold after ALE Low	48		$t_{\text{CLCL}}-25$		ns
$t_{\text{LLIV}}$	ALE Low to Valid Instruction In		233		$4t_{\text{CLCL}}-65$	ns
$t_{\text{LLPL}}$	ALE Low to $\overline{\text{PSEN}}$ Low	43		$t_{\text{CLCL}}-25$		ns
$t_{\text{PLPH}}$	$\overline{\text{PSEN}}$ Pulse Width	205		$3t_{\text{CLCL}}-45$		ns
$t_{\text{PLIV}}$	$\overline{\text{PSEN}}$ Low to Valid Instruction In		145		$3t_{\text{CLCL}}-60$	ns
$t_{\text{PXIX}}$	Input Instruction Hold after $\overline{\text{PSEN}}$	0		0		ns
$t_{\text{PXIZ}}$	Input Instruction Float after $\overline{\text{PSEN}}$		59		$t_{\text{CLCL}}-25$	ns
$t_{\text{PXAV}}$	$\overline{\text{PSEN}}$ to Address Valid	75		$t_{\text{CLCL}}-8$		ns
$t_{\text{AVIV}}$	Address to Valid Instruction In		312		$5t_{\text{CLCL}}-80$	ns
$t_{\text{PLAZ}}$	$\overline{\text{PSEN}}$ Low to Address Float		10		10	ns
$t_{\text{RLRH}}$	$\overline{\text{RD}}$ Pulse Width	400		$6t_{\text{CLCL}}-100$		ns
$t_{\text{WLWH}}$	$\overline{\text{WR}}$ Pulse Width	400		$6t_{\text{CLCL}}-100$		ns
$t_{\text{RLDV}}$	$\overline{\text{RD}}$ Low to Valid Data In		252		$5t_{\text{CLCL}}-90$	ns
$t_{\text{RHDX}}$	Data Hold after $\overline{\text{RD}}$	0		0		ns
$t_{\text{RHDZ}}$	Data Float after $\overline{\text{RD}}$		97		$2t_{\text{CLCL}}-28$	ns
$t_{\text{LLDV}}$	ALE Low to Valid Data In		517		$8t_{\text{CLCL}}-150$	ns
$t_{\text{AVDV}}$	Address to Valid Data In		585		$9t_{\text{CLCL}}-165$	ns
$t_{\text{LLWL}}$	ALE Low to $\overline{\text{RD}}$ or $\overline{\text{WR}}$ Low	200	300	$3t_{\text{CLCL}}-50$	$3t_{\text{CLCL}}+50$	ns
$t_{\text{AVWL}}$	Address to $\overline{\text{RD}}$ or $\overline{\text{WR}}$ Low	203		$4t_{\text{CLCL}}-75$		ns
$t_{\text{QVWX}}$	Data Valid to $\overline{\text{WR}}$ Transition	23		$t_{\text{CLCL}}-30$		ns
$t_{\text{QVWH}}$	Data Valid to $\overline{\text{WR}}$ High	433		$7t_{\text{CLCL}}-130$		ns
$t_{\text{WHQX}}$	Data Hold after $\overline{\text{WR}}$	33		$t_{\text{CLCL}}-25$		ns
$t_{\text{RLAZ}}$	$\overline{\text{RD}}$ Low to Address Float		0		0	ns
$t_{\text{WHLH}}$	$\overline{\text{RD}}$ or $\overline{\text{WR}}$ High to ALE High	43	123	$t_{\text{CLCL}}-25$	$t_{\text{CLCL}}+25$	ns

## External Program Memory Read Cycle

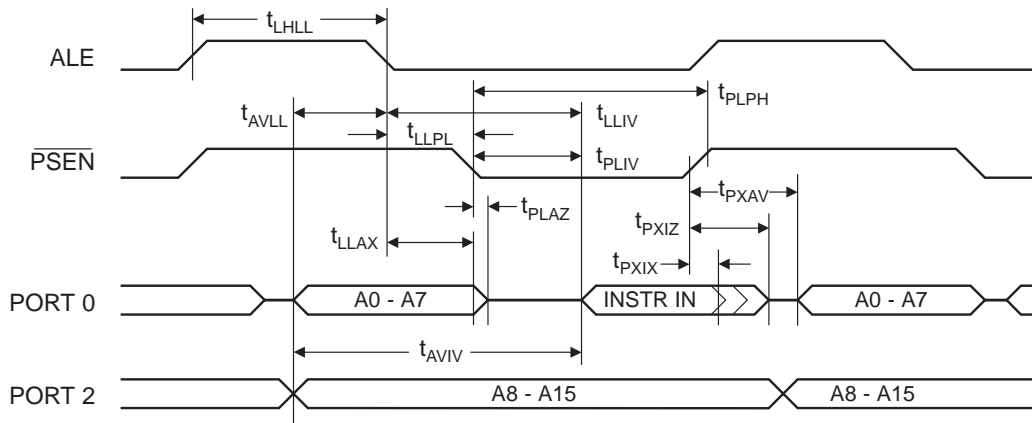

## External Data Memory Read Cycle

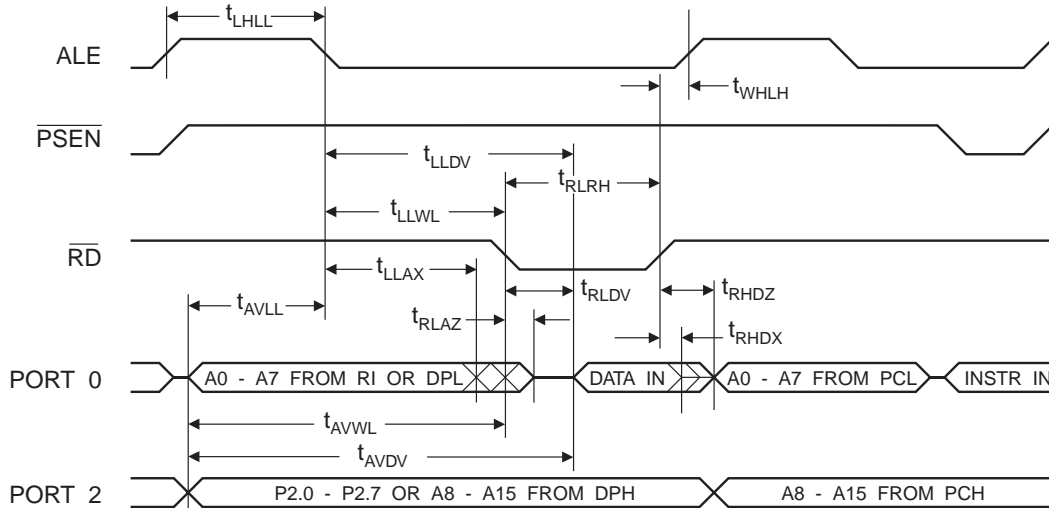

## External Data Memory Write Cycle

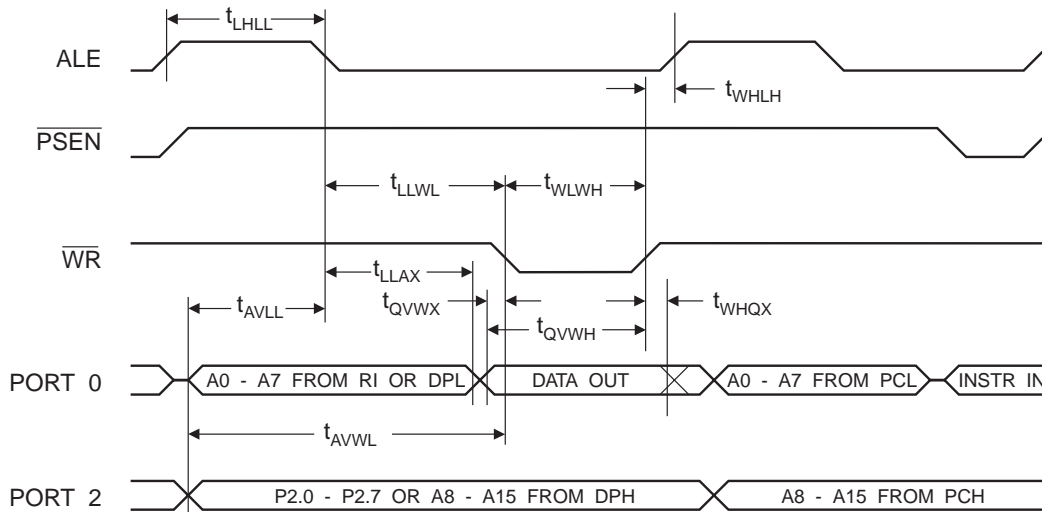

## External Clock Drive Waveforms

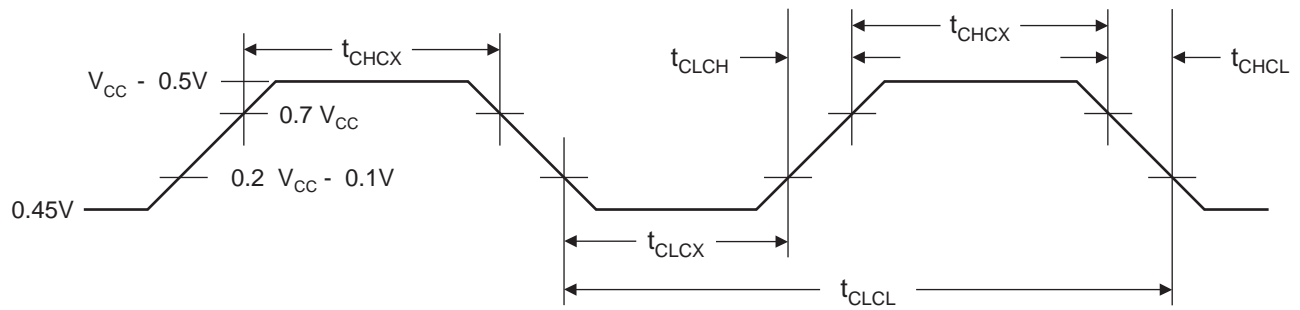

## External Clock Drive

Symbol	Parameter	Min	Max	Units
$1/t_{CLCL}$	Oscillator Frequency	0	33	MHz
$t_{CLCL}$	Clock Period	30		ns
$t_{CHCX}$	High Time	12		ns
$t_{CLCX}$	Low Time	12		ns
$t_{CLCH}$	Rise Time		5	ns
$t_{CHCL}$	Fall Time		5	ns

## Serial Port Timing: Shift Register Mode Test Conditions

The values in this table are valid for  $V_{CC} = 4.0V$  to  $5.5V$  and Load Capacitance =  $80\text{ pF}$ .

Symbol	Parameter	12 MHz Osc		Variable Oscillator		Units
		Min	Max	Min	Max	
$t_{XLXL}$	Serial Port Clock Cycle Time	1.0		$12t_{CLCL}$		$\mu\text{s}$
$t_{QVXH}$	Output Data Setup to Clock Rising Edge	700		$10t_{CLCL} - 133$		ns
$t_{XHGX}$	Output Data Hold after Clock Rising Edge	50		$2t_{CLCL} - 80$		ns
$t_{XHDX}$	Input Data Hold after Clock Rising Edge	0		0		ns
$t_{XHDV}$	Clock Rising Edge to Input Data Valid		700		$10t_{CLCL} - 133$	ns

## Shift Register Mode Timing Waveforms

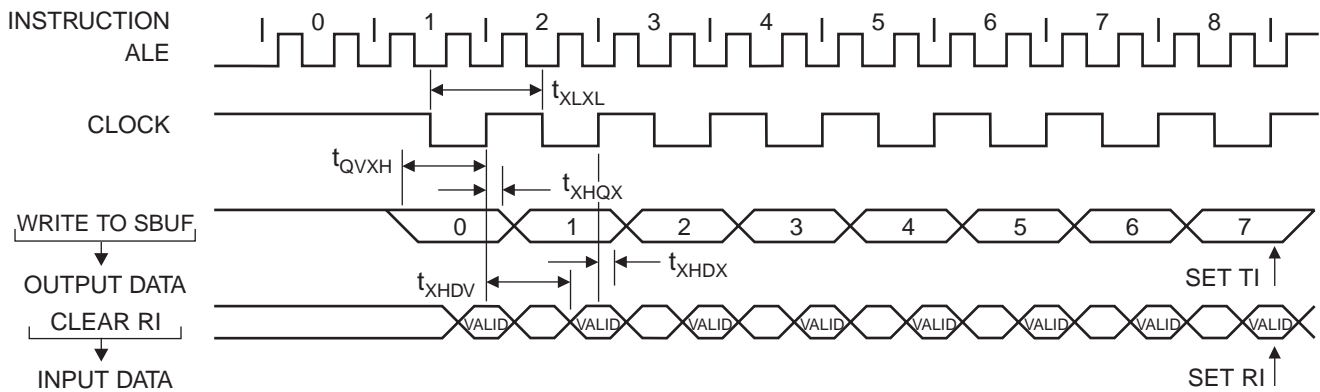

## AC Testing Input/Output Waveforms<sup>(1)</sup>

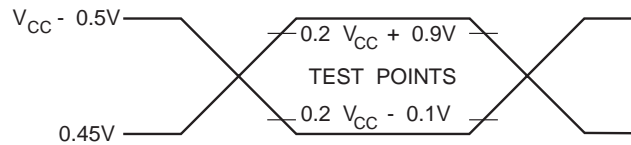

Note: 1. AC Inputs during testing are driven at  $V_{CC} - 0.5V$  for a logic 1 and  $0.45V$  for a logic 0. Timing measurements are made at  $V_{IH}$  min. for a logic 1 and  $V_{IL}$  max. for a logic 0.

## Float Waveforms<sup>(1)</sup>

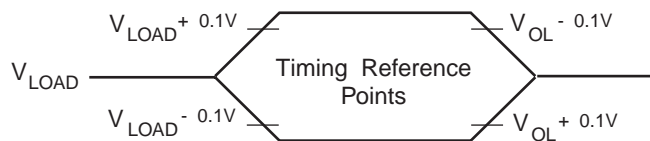

Note: 1. For timing purposes, a port pin is no longer floating when a  $100\text{ mV}$  change from load voltage occurs. A port pin begins to float when a  $100\text{ mV}$  change from the loaded  $V_{OH}/V_{OL}$  level occurs.

## Ordering Information

Speed (MHz)	Power Supply	Ordering Code	Package	Operation Range
24	4.0V to 5.5V	AT89C51RC-24AC	44A	Commercial (0°C to 70°C)
		AT89C51RC-24JC	44J	
		AT89C51RC-24PC	40P6	
		AT89C51RC-24AI	44A	Industrial (-40°C to 85°C)
		AT89C51RC-24JI	44J	
		AT89C51RC-24PI	40P6	
33	4.5V to 5.5V	AT89C51RC-33AC	44A	Commercial (0°C to 70°C)
		AT89C51RC-33JC	44J	
		AT89C51RC-33PC	40P6	

Package Type	
<b>44A</b>	44-lead, Thin Plastic Gull Wing Quad Flatpack (TQFP)
<b>44J</b>	44-lead, Plastic J-leaded Chip Carrier (PLCC)
<b>40P6</b>	40-lead, 0.600" Wide, Plastic Dual Inline Package (PDIP)

# 44A – TQFP

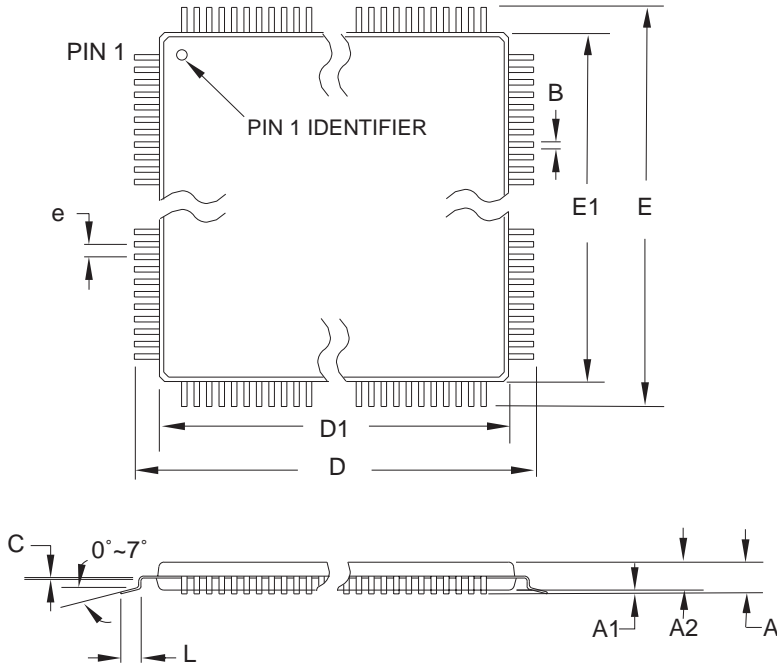

**COMMON DIMENSIONS**  
(Unit of Measure = mm)

SYMBOL	MIN	NOM	MAX	NOTE
A	–	–	1.20	
A1	0.05	–	0.15	
A2	0.95	1.00	1.05	
D	11.75	12.00	12.25	
D1	9.90	10.00	10.10	Note 2
E	11.75	12.00	12.25	
E1	9.90	10.00	10.10	Note 2
B	0.30	–	0.45	
C	0.09	–	0.20	
L	0.45	–	0.75	
e	0.80 TYP			

- Notes:
1. This package conforms to JEDEC reference MS-026, Variation ACB.
  2. Dimensions D1 and E1 do not include mold protrusion. Allowable protrusion is 0.25 mm per side. Dimensions D1 and E1 are maximum plastic body size dimensions including mold mismatch.
  3. Lead coplanarity is 0.10 mm maximum.

10/5/2001

2325 Orchard Parkway  
San Jose, CA 95131

**TITLE**  
44A, 44-lead, 10 x 10 mm Body Size, 1.0 mm Body Thickness,  
0.8 mm Lead Pitch, Thin Profile Plastic Quad Flat Package (TQFP)

**DRAWING NO.** 44A  
**REV.** B

44J – PLCC

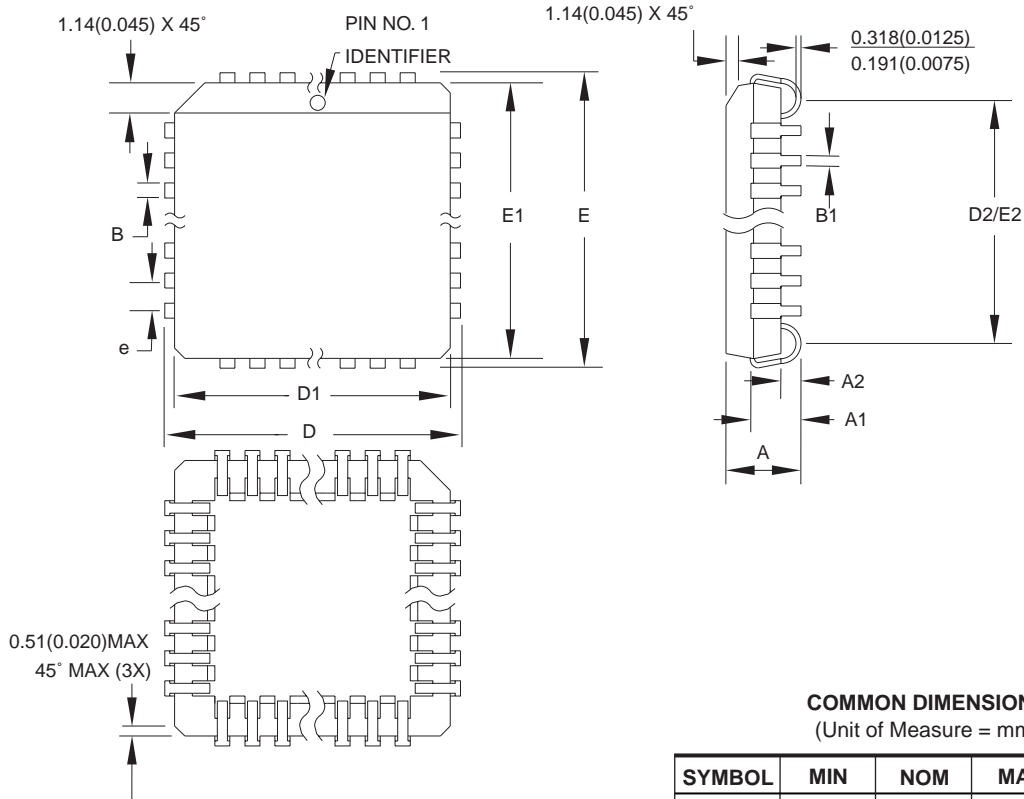

**COMMON DIMENSIONS**  
(Unit of Measure = mm)

SYMBOL	MIN	NOM	MAX	NOTE
A	4.191	–	4.572	
A1	2.286	–	3.048	
A2	0.508	–	–	
D	17.399	–	17.653	
D1	16.510	–	16.662	Note 2
E	17.399	–	17.653	
E1	16.510	–	16.662	Note 2
D2/E2	14.986	–	16.002	
B	0.660	–	0.813	
B1	0.330	–	0.533	
e	1.270 TYP			

- Notes:
1. This package conforms to JEDEC reference MS-018, Variation AC.
  2. Dimensions D1 and E1 do not include mold protrusion. Allowable protrusion is .010"(0.254 mm) per side. Dimension D1 and E1 include mold mismatch and are measured at the extreme material condition at the upper or lower parting line.
  3. Lead coplanarity is 0.004" (0.102 mm) maximum.

10/04/01

**ATMEL** 2325 Orchard Parkway  
San Jose, CA 95131

**TITLE**  
44J, 44-lead, Plastic J-leaded Chip Carrier (PLCC)

**DRAWING NO.** 44J  
**REV.** B

# 40P6 – PDIP

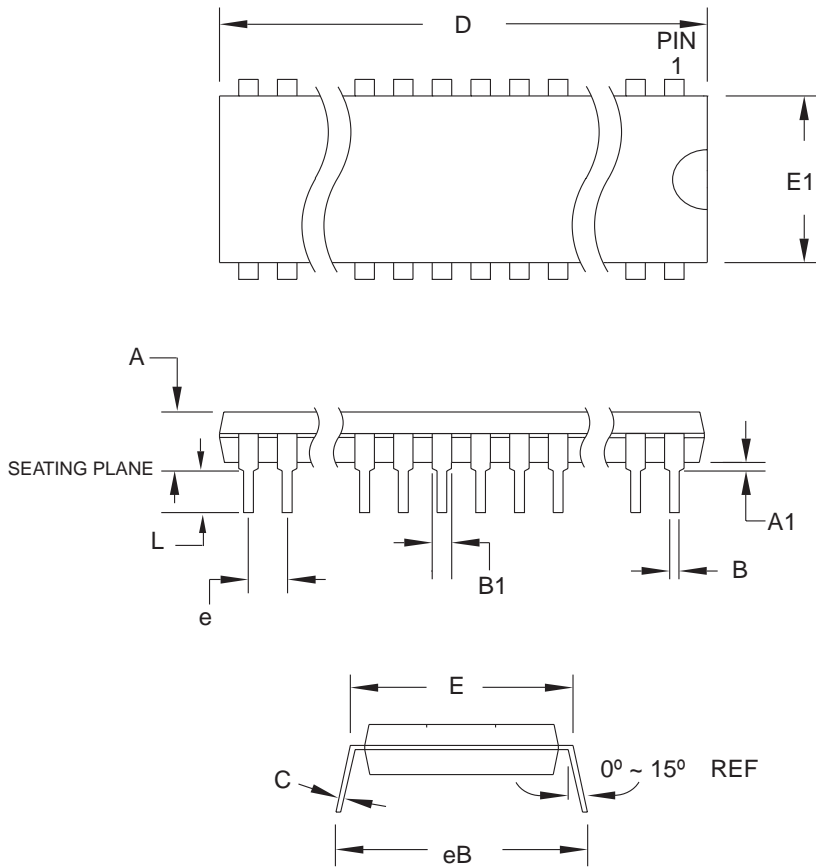

**COMMON DIMENSIONS**  
(Unit of Measure = mm)

SYMBOL	MIN	NOM	MAX	NOTE
A	–	–	4.826	
A1	0.381	–	–	
D	52.070	–	52.578	Note 2
E	15.240	–	15.875	
E1	13.462	–	13.970	Note 2
B	0.356	–	0.559	
B1	1.041	–	1.651	
L	3.048	–	3.556	
C	0.203	–	0.381	
eB	15.494	–	17.526	
e	2.540 TYP			

- Notes: 1. This package conforms to JEDEC reference MS-011, Variation AC.  
 2. Dimensions D and E1 do not include mold Flash or Protrusion. Mold Flash or Protrusion shall not exceed 0.25 mm (0.010").

09/28/01



2325 Orchard Parkway  
San Jose, CA 95131

**TITLE**

**40P6**, 40-lead (0.600"/15.24 mm Wide) Plastic Dual Inline Package (PDIP)

**DRAWING NO.**

40P6

**REV.**

B



## Atmel Headquarters

### *Corporate Headquarters*

2325 Orchard Parkway  
San Jose, CA 95131  
USA  
TEL 1(408) 441-0311  
FAX 1(408) 487-2600

### *Europe*

Atmel Sarl  
Route des Arsenaux 41  
Case Postale 80  
CH-1705 Fribourg  
Switzerland  
TEL (41) 26-426-5555  
FAX (41) 26-426-5500

### *Asia*

Room 1219  
Chinachem Golden Plaza  
77 Mody Road Tsimshatsui  
East Kowloon  
Hong Kong  
TEL (852) 2721-9778  
FAX (852) 2722-1369

### *Japan*

9F, Tonetsu Shinkawa Bldg.  
1-24-8 Shinkawa  
Chuo-ku, Tokyo 104-0033  
Japan  
TEL (81) 3-3523-3551  
FAX (81) 3-3523-7581

## Atmel Operations

### *Memory*

2325 Orchard Parkway  
San Jose, CA 95131  
TEL 1(408) 441-0311  
FAX 1(408) 436-4314

### *Microcontrollers*

2325 Orchard Parkway  
San Jose, CA 95131  
TEL 1(408) 441-0311  
FAX 1(408) 436-4314

La Chantrerie  
BP 70602  
44306 Nantes Cedex 3, France  
TEL (33) 2-40-18-18-18  
FAX (33) 2-40-18-19-60

### *ASIC/ASSP/Smart Cards*

Zone Industrielle  
13106 Rousset Cedex, France  
TEL (33) 4-42-53-60-00  
FAX (33) 4-42-53-60-01

1150 East Cheyenne Mtn. Blvd.  
Colorado Springs, CO 80906  
TEL 1(719) 576-3300  
FAX 1(719) 540-1759

Scottish Enterprise Technology Park  
Maxwell Building  
East Kilbride G75 0QR, Scotland  
TEL (44) 1355-803-000  
FAX (44) 1355-242-743

### *RF/Automotive*

Theresienstrasse 2  
Postfach 3535  
74025 Heilbronn, Germany  
TEL (49) 71-31-67-0  
FAX (49) 71-31-67-2340

1150 East Cheyenne Mtn. Blvd.  
Colorado Springs, CO 80906  
TEL 1(719) 576-3300  
FAX 1(719) 540-1759

### *Biometrics/Imaging/Hi-Rel MPU/ High Speed Converters/RF Datacom*

Avenue de Rochepleine  
BP 123  
38521 Saint-Egreve Cedex, France  
TEL (33) 4-76-58-30-00  
FAX (33) 4-76-58-34-80

---

### *e-mail*

[literature@atmel.com](mailto:literature@atmel.com)

### *Web Site*

<http://www.atmel.com>

### © Atmel Corporation 2002.

Atmel Corporation makes no warranty for the use of its products, other than those expressly contained in the Company's standard warranty which is detailed in Atmel's Terms and Conditions located on the Company's web site. The Company assumes no responsibility for any errors which may appear in this document, reserves the right to change devices or specifications detailed herein at any time without notice, and does not make any commitment to update the information contained herein. No licenses to patents or other intellectual property of Atmel are granted by the Company in connection with the sale of Atmel products, expressly or by implication. Atmel's products are not authorized for use as critical components in life support devices or systems.

ATMEL® is the registered trademark of Atmel. MCS®51 is a registered trademark of Intel Corporation.

Other terms and product names may be the trademarks of others.



Printed on recycled paper.