



MBR2035CT THRU MBR20200CT

20.0 AMPS. Schottky Barrier Rectifiers



Voltage Range
35 to 200 Volts
Current
20.0 Amperes

Features

- ✦ Plastic material used carries Underwriters Laboratory Classifications 94V-0
- ✦ Metal silicon junction, majority carrier conduction
- ✦ Low power loss, high efficiency
- ✦ High current capability, low forward voltage drop
- ✦ High surge capability
- ✦ For use in low voltage, high frequency inverters, free wheeling, and polarity protection applications
- ✦ Guardring for overvoltage protection
- ✦ High temperature soldering guaranteed: 260°C/10 seconds, 0.25"(6.35mm) from case

Mechanical Data

- ✦ Cases: JEDEC TO-220 molded plastic
- ✦ Terminals: Leads solderable per MIL-STD-750, Method 2026
- ✦ Polarity: As marked
- ✦ Mounting position: Any
- ✦ Mounting torque: 5 in. - lbs. max
- ✦ Weight: 0.08 ounce, 2.24 grams

TO-220

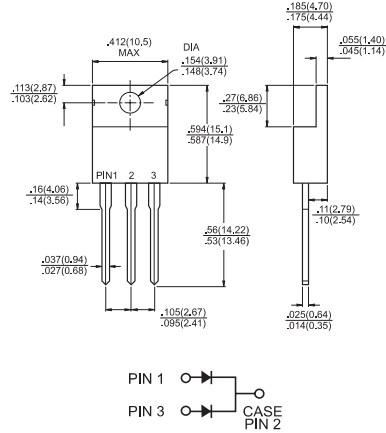

Dimensions in inches and (millimeters)

Maximum Ratings and Electrical Characteristics

Rating at 25°C ambient temperature unless otherwise specified.

Single phase, half wave, 60 Hz, resistive or inductive load.

For capacitive load, derate current by 20%

Type Number	Symbol	MBR 2035CT	MBR 2045CT	MBR 2050CT	MBR 2060CT	MBR 20100CT	MBR 20200CT	Units
Maximum Recurrent Peak Reverse Voltage	V_{RRM}	35	45	50	60	100	200	V
Maximum RMS Voltage	V_{RMS}	24	31	35	42	70	140	V
Maximum DC Blocking Voltage	V_{DC}	35	45	50	60	10	200	V
Maximum Average Forward Rectified Current at $T_C=135^\circ\text{C}$	$I_{(AV)}$	20						A
Peak Repetitive Forward Current (Rated V_R , Square Wave, 20KHz) at $T_C=135^\circ\text{C}$	I_{FRM}	20.0						A
Peak Forward Surge Current, 8.3 ms Single Half Sine-wave Superimposed on Rated Load (JEDEC method)	I_{FSM}	150						A
Peak Repetitive Reverse Surge Current (Note 1)	I_{RRM}	1.0	0.5			1.0	A	
Maximum Instantaneous Forward Voltage at (Note 2) IF=10A, TC=25°C IF=10A, TC=125°C IF=20A, TC=25°C IF=20A, TC=125°C	V_F	0.57 0.84 0.72	0.80 0.70 0.95 0.85		0.85 0.75 0.95 0.85	0.99 0.87 1.23 1.10	V	
Maximum Instantaneous Reverse Current @ $T_C=25^\circ\text{C}$ at Rated DC Blocking Voltage @ $T_C=125^\circ\text{C}$	I_R	0.1 15.0	0.15 150.0			1.0 50	mA mA	
Voltage Rate of Change, (Rated V_R)	dV/dt	10,000						V/ μs
Typical Junction Capacitance	C_j	400	320				pF	
Typical Thermal Resistance Per Leg (Note 3)	$R_{\theta JC}$	1.0			2.0		°C/W	
Operating Junction Temperature Range	T_J	-65 to +150						°C
Storage Temperature Range	T_{STG}	-65 to +175						°C

Notes: 1. 2.0us Pulse Width, $f=1.0$ KHz

2. Pulse Test: 300us Pulse Width, 1% Duty Cycle

3. Thermal Resistance from Junction to Case Per Leg, with Heatsink Size (4"x6"x0.25") Al-Plate.

RATINGS AND CHARACTERISTIC CURVES (MBR2035CT THRU MBR20200CT)

FIG.1- FORWARD CURRENT DERATING CURVE

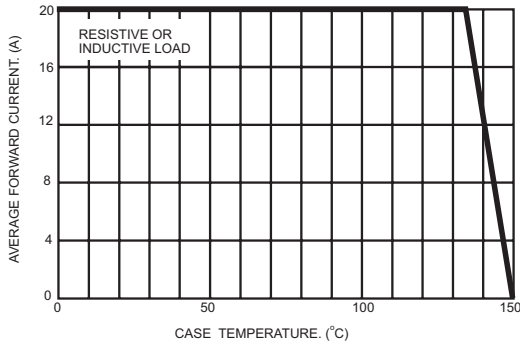

FIG.2- MAXIMUM NON-REPETITIVE FORWARD SURGE CURRENT PER LEG

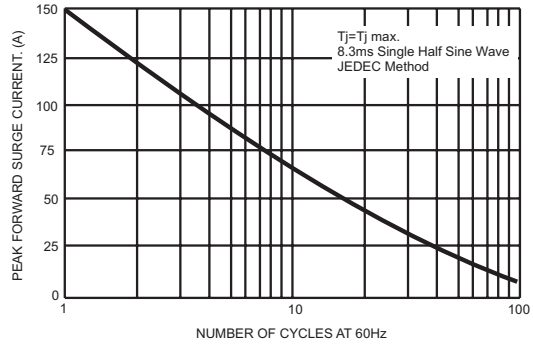

FIG.3- TYPICAL INSTANTANEOUS FORWARD CHARACTERISTICS PER LEG

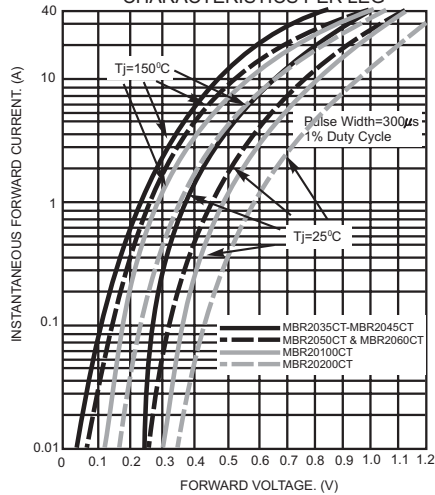

FIG.4- TYPICAL REVERSE CHARACTERISTICS PER LEG

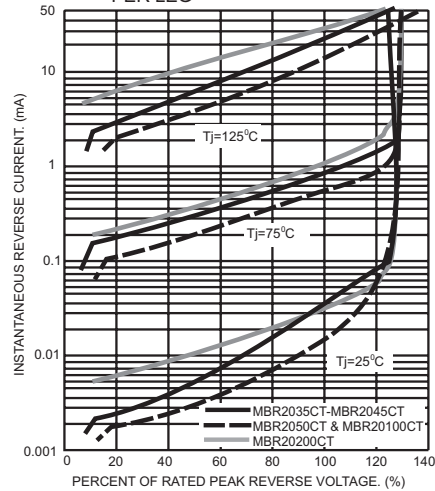

FIG.5- TYPICAL JUNCTION CAPACITANCE PER LEG

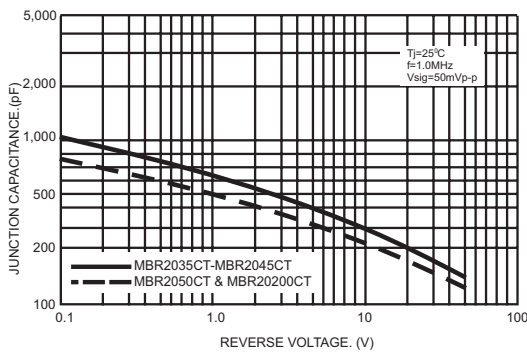

FIG.6- TYPICAL TRANSIENT THERMAL IMPEDANCE PER LEG

