



# EMIF06-HMC01F2

IPAD™

## 6 LINES EMI FILTER INCLUDING ESD PROTECTION

### MAIN APPLICATION

- High Speed MultiMediaCard™

### DESCRIPTION

The EMIF06-HMC01F2 is a highly integrated array designed to suppress EMI / RFI noise for High Speed MultiMediaCard™ port filtering. The EMIF06-HMC01F2 Flip-Chip packaging means the package size is equal to the die size. Additionally, this filter includes an ESD protection circuitry which prevents the protected device from destruction when subjected to ESD surges up to 15 kV.

### BENEFITS

- 6 lines low-pass-filter
- High efficiency in EMI filtering
- Very low PCB space consuming: < 4.4 mm<sup>2</sup>
- Lead Free package
- Very thin package: 0.65 mm
- High efficiency in ESD suppression
- High reliability offered by monolithic integration
- High reducing of parasitic elements through integration & wafer level packaging

### COMPLIES WITH THE FOLLOWING STANDARDS: IEC61000-4-2

Level 4 on external pins 15kV (air discharge)  
8kV (contact discharge)

MIL STD 883E - Method 3015-6 Class 3

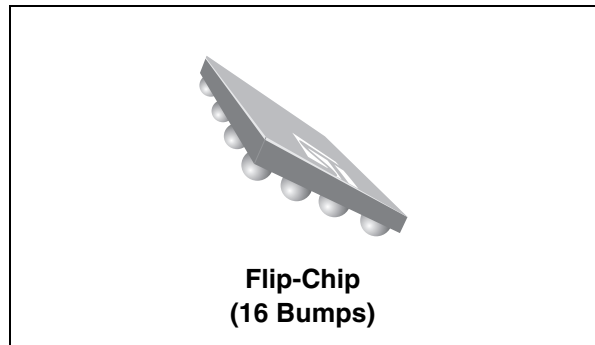

Table 1: Order Code

Part Number	Marking
EMIF06-HMC01F2	GH

Figure 1: Pin Configuration (ball side)

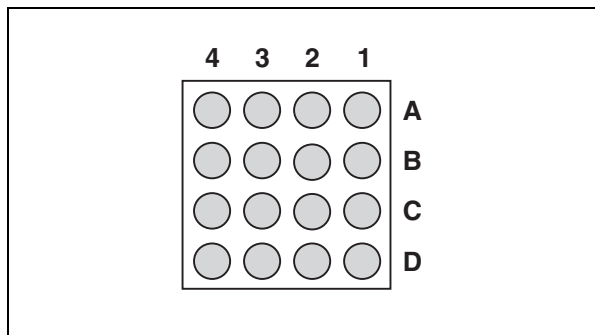

Figure 2: Configuration

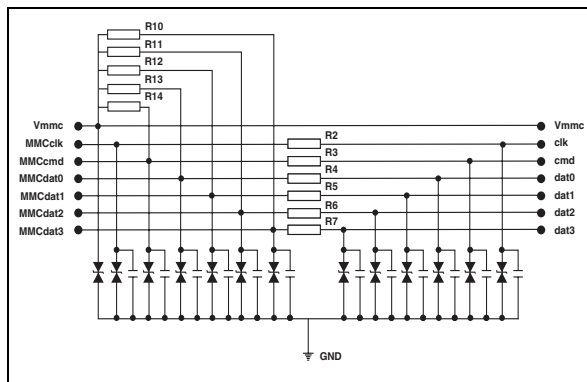

Table 2: Ball configuration

<b>A1</b>	cmd	<b>C1</b>	dat2
<b>A2</b>	clk	<b>C2</b>	gnd
<b>A3</b>	Vmmc/Vdd	<b>C3</b>	MMCdat1
<b>A4</b>	MMCclk	<b>C4</b>	MMCdat0
<b>B1</b>	dat1	<b>D1</b>	dat3
<b>B2</b>	dat0	<b>D2</b>	gnd
<b>B3</b>	gnd	<b>D3</b>	MMCdat3
<b>B4</b>	MMCcmd	<b>D4</b>	MMCdat2

TM: IPAD is a trademark of STMicroelectronics.

## EMIF06-HMC01F2

**Table 3: Absolute Maximum Ratings** ( $T_{amb} = 25^{\circ}\text{C}$ )

Symbol	Parameter and test conditions	Value	Unit
$V_{PP}$	<b>Internal pins (A4, B4, C3, C4, D3, D4):</b>		
	ESD discharge IEC61000-4-2, air discharge	2	kV
	ESD discharge IEC61000-4-2, contact discharge	2	
	<b>External pins (A1, A2, A3, B1, B2, C1, D1):</b>		
ESD discharge IEC61000-4-2, air discharge	15		
	ESD discharge IEC61000-4-2, contact discharge	8	
$T_j$	Maximum junction temperature	125	$^{\circ}\text{C}$
$T_{op}$	Operating temperature range	- 40 to + 85	$^{\circ}\text{C}$
$T_{stg}$	Storage temperature range	- 55 to + 150	$^{\circ}\text{C}$

**Table 4: Electrical Characteristics** ( $T_{amb} = 25^{\circ}\text{C}$ )

Symbol	Parameter
$V_{BR}$	Breakdown voltage
$I_{RM}$	Leakage current @ $V_{RM}$
$V_{RM}$	Stand-off voltage
$C_{line}$	Input capacitance per line

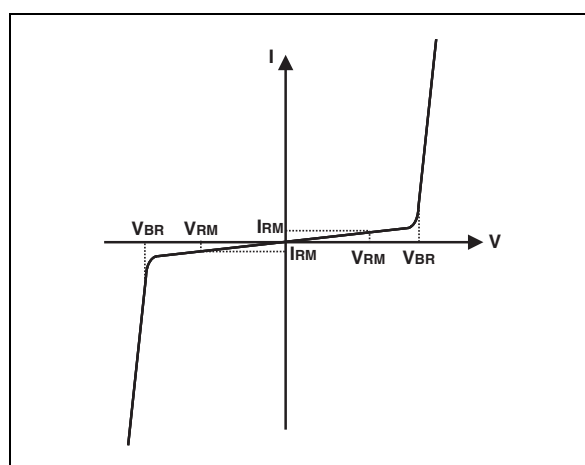

Symbol	Test conditions	Tolerance	Min.	Typ.	Max.	Unit
$V_{BR}$	$I_R = 1 \text{ mA}$		14			V
$I_{RM}$	$V_{RM} = 3\text{V}$				0.1	$\mu\text{A}$
$C_{line}$	@ 0V				20	pF
$R_2, R_3, R_4, R_5, R_6, R_7$	$I = 50 \text{ mA}$	$\pm 20\%$		50		$\Omega$
$R_{10}, R_{11}, R_{12}, R_{13}$	$I = 50 \mu\text{A}$	$\pm 30\%$		75		$\text{k}\Omega$
$R_{14}$	$I = 200 \mu\text{A}$	$\pm 30\%$		7		$\text{k}\Omega$

Figure 3: S21 (dB) attenuation measurement

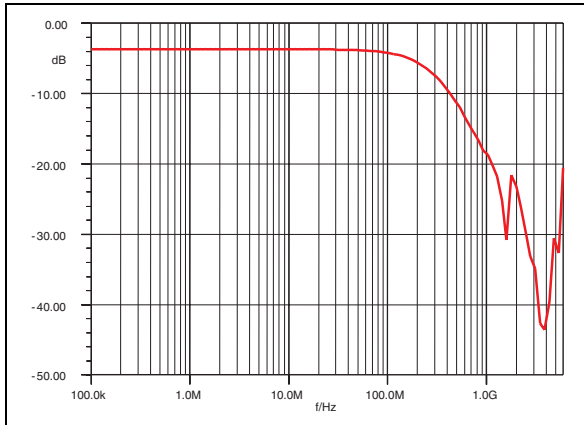

Figure 4: Analog crosstalk measurement

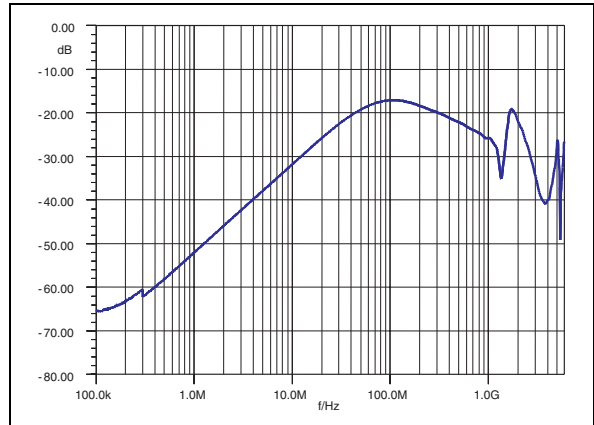

Figure 5: ESD response to IEC61000-4-2 (+15kV air discharge) on one input V(in) and on one output (Vout)

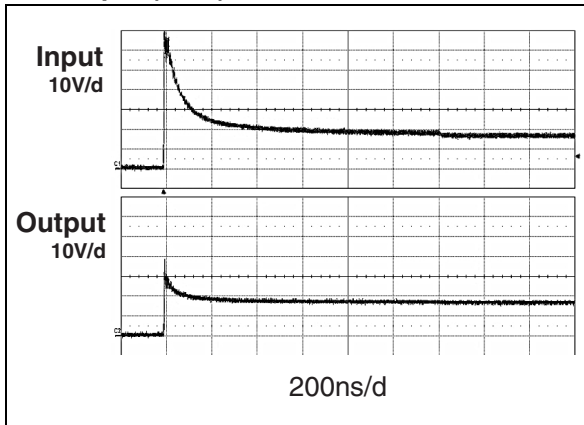

Figure 6: ESD response to IEC61000-4-2 (-15kV air discharge) on one input V(in) and on one output (Vout)

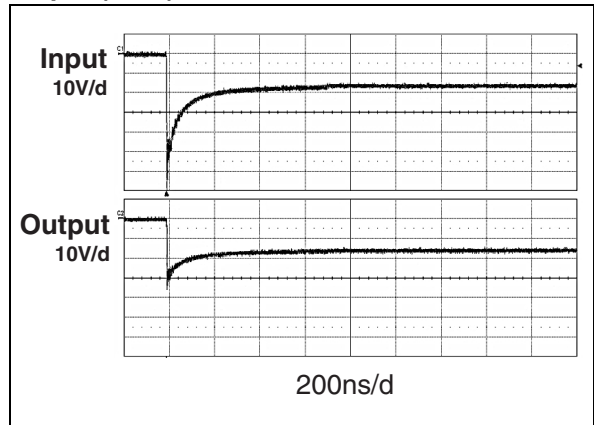

Figure 7: Junction capacitance versus reverse voltage applied (typical values)

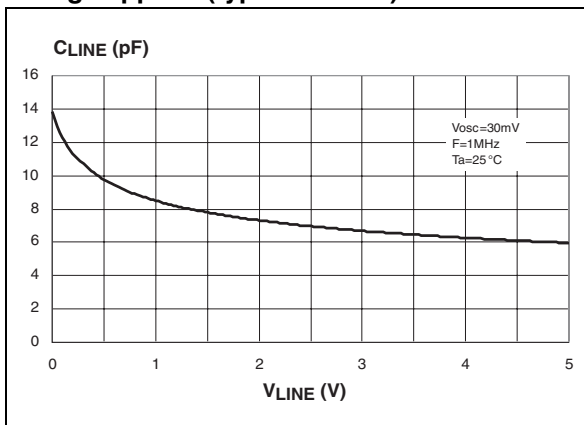

Figure 8: Aplac model device structure

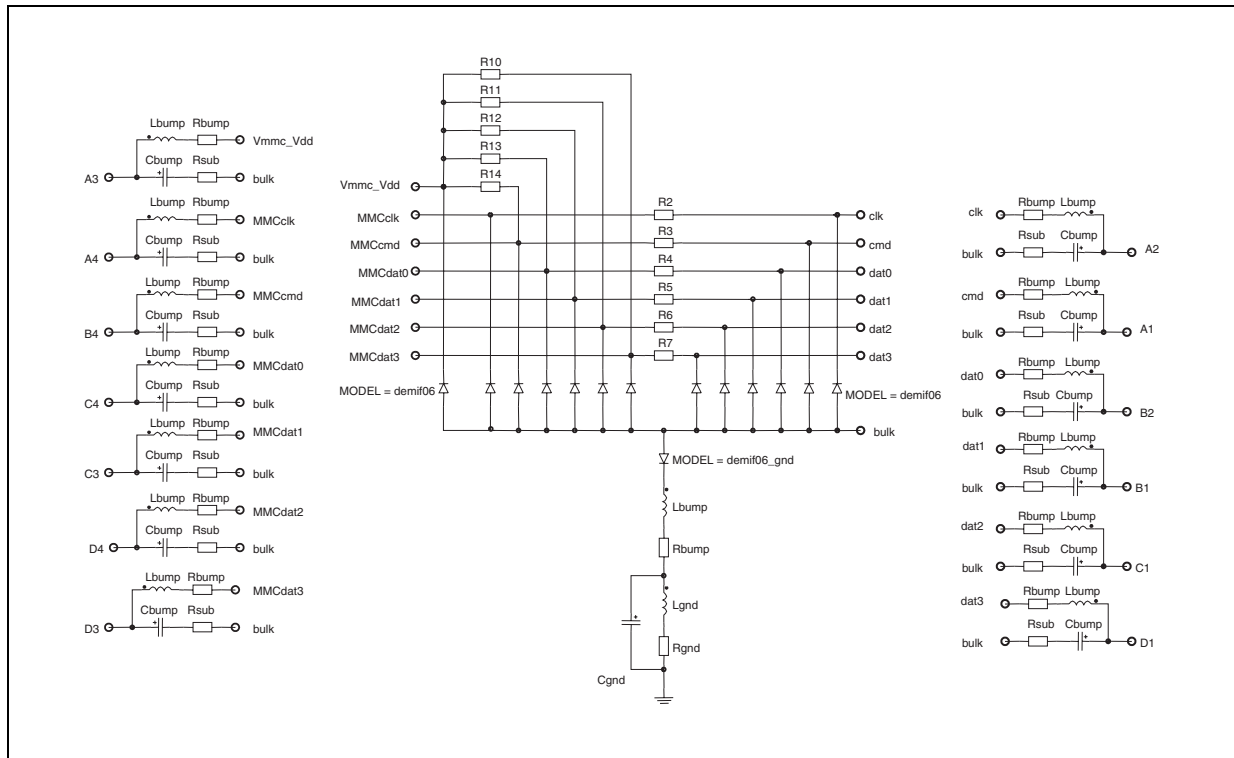

Figure 9: APLAC model parameters

Variables	Variables	demif06_gnd	demif06
R2 50	Cz 11pF	BV=14	BV=14
R3 50	Cz_gnd 45pF	IBV=1m	IBV=1m
R4 50	RS_gnd 480m	CJO=Cz_gnd	CJO=Cz
R5 50	Ls 950pH	M=0.31	M=0.31
R6 50	Rs 150m	RS=RS_gnd	RS=1
R7 50	Rbump 100m	VJ=0.6	VJ=0.6
R10 75k	Lbump 50pH	TT=100n	TT=100n
R11 75k	Cbump 0.15pF		
R12 75k	Lgnd 50pH		
R13 75k	Rgnd 100m		
R14 7k	Cgnd 0.15pF		
Rsub 100m			

Figure 10: Ordering Information Scheme

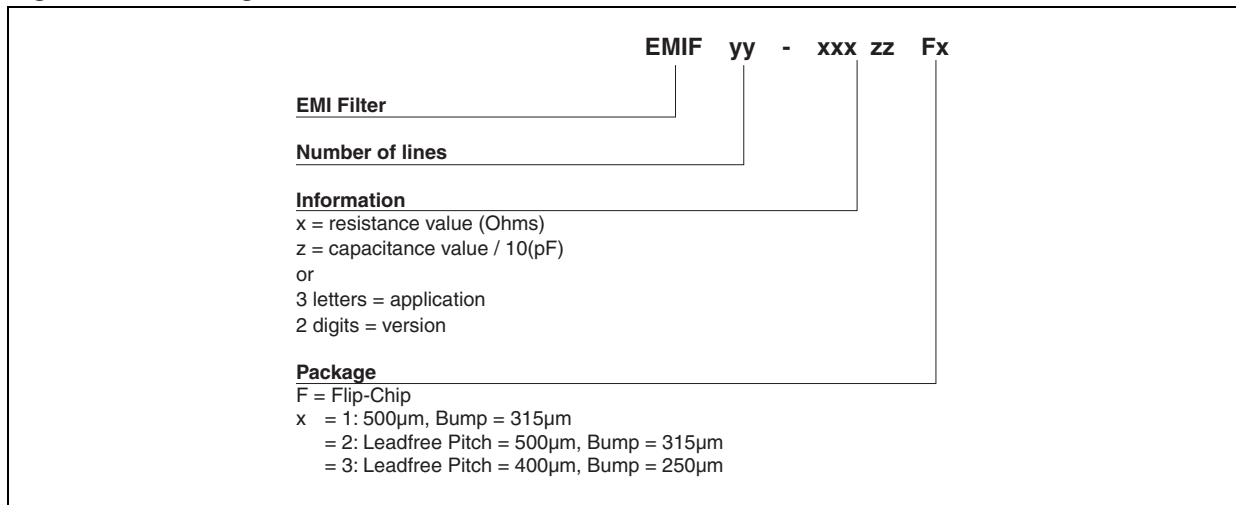

Figure 11: FLIP-CHIP Package Mechanical Data

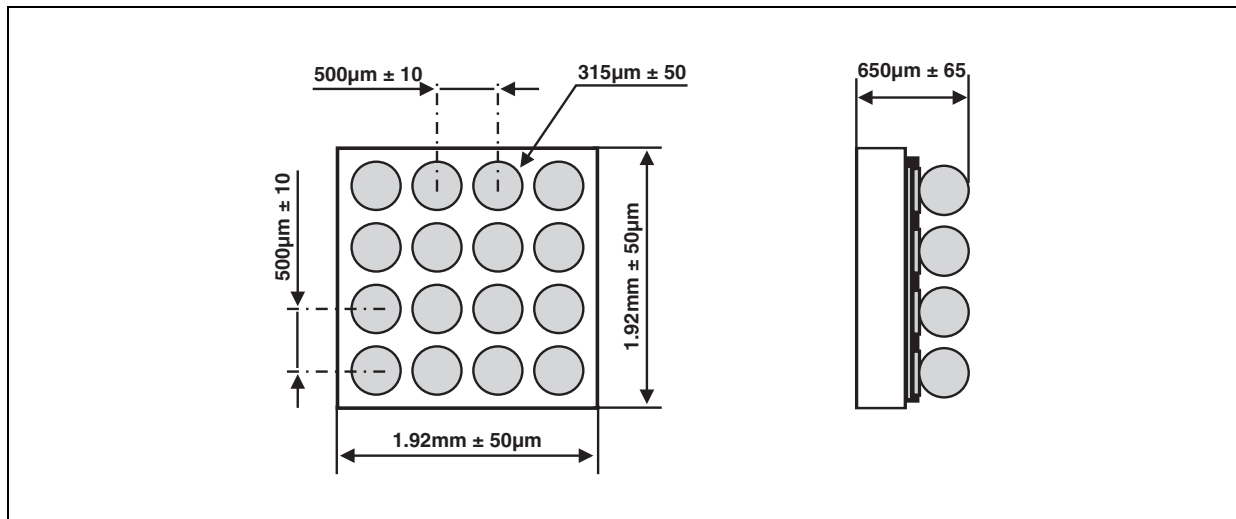

Figure 12: Foot Print Recommendations

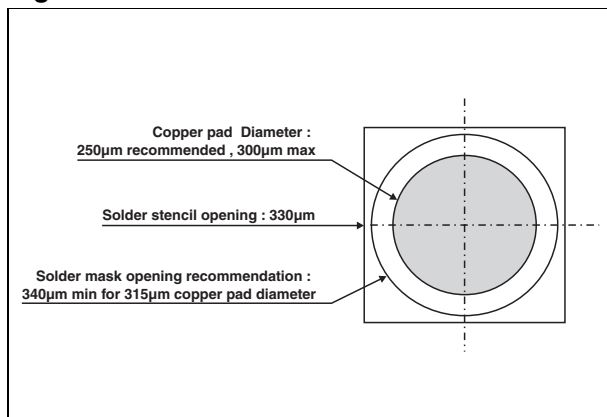

Figure 13: Marking

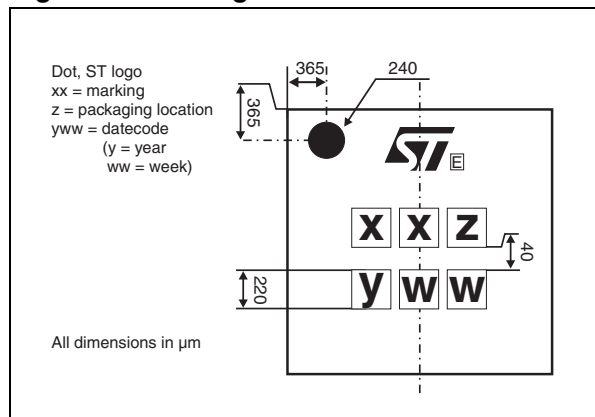

Figure 14: FLIP-CHIP Tape and Reel Specification

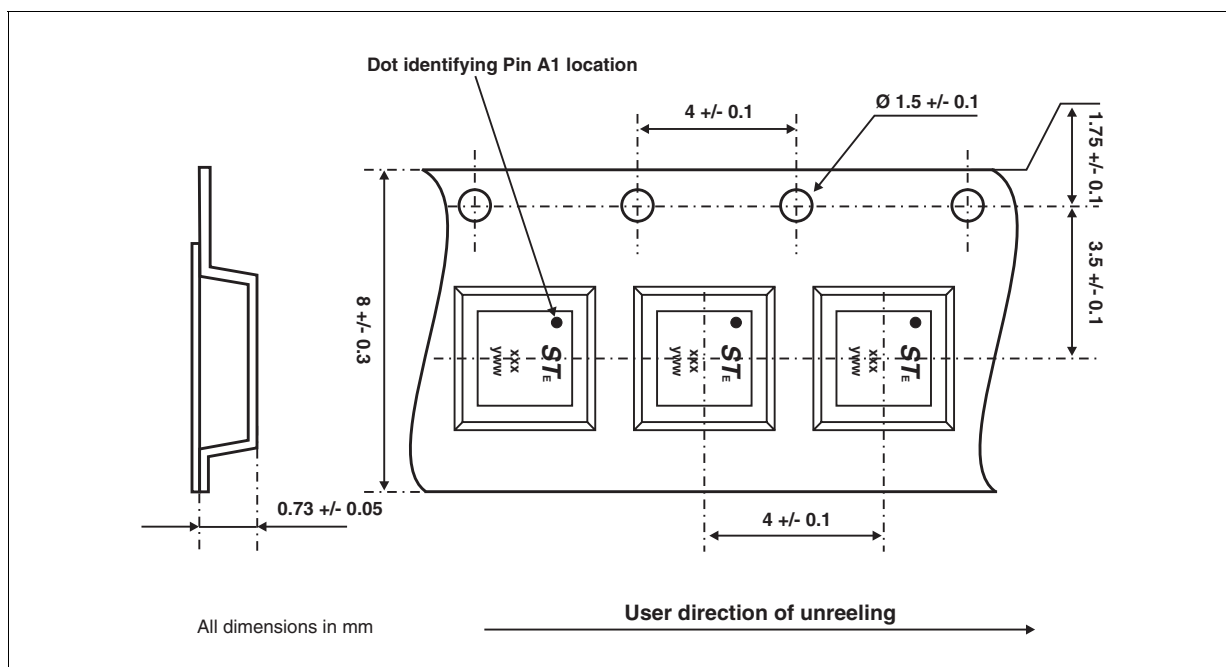

Table 5: Ordering Information

Ordering code	Marking	Package	Weight	Base qty	Delivery mode
EMIF06-HMC01F2	GH	Flip-Chip	5.3 mg	5000	Tape & reel 7"

**Note:** More packing informations are available in the application note AN1235: "Flip-Chip: Package description and recommendations for use"

Table 6: Revision History

Date	Revision	Description of Changes
25-Jan-2005	1	First issue.

Information furnished is believed to be accurate and reliable. However, STMicroelectronics assumes no responsibility for the consequences of use of such information nor for any infringement of patents or other rights of third parties which may result from its use. No license is granted by implication or otherwise under any patent or patent rights of STMicroelectronics. Specifications mentioned in this publication are subject to change without notice. This publication supersedes and replaces all information previously supplied. STMicroelectronics products are not authorized for use as critical components in life support devices or systems without express written approval of STMicroelectronics.

The ST logo is a registered trademark of STMicroelectronics.  
All other names are the property of their respective owners

© 2005 STMicroelectronics - All rights reserved

**STMicroelectronics group of companies**

Australia - Belgium - Brazil - Canada - China - Czech Republic - Finland - France - Germany - Hong Kong - India - Israel - Italy - Japan -  
Malaysia - Malta - Morocco - Singapore - Spain - Sweden - Switzerland - United Kingdom - United States of America  
[www.st.com](http://www.st.com)

