



# STM690, STM704, STM795 STM802, STM804, STM805, STM806

## 3V Supervisor with Battery Switchover

### FEATURES SUMMARY

- RST OR  $\overline{\text{RST}}$  OUTPUTS
- NVRAM SUPERVISOR FOR EXTERNAL LPSRAM
- CHIP-ENABLE GATING (STM795 only) FOR EXTERNAL LPSRAM (7ns max PROP DELAY)
- MANUAL (PUSH-BUTTON) RESET INPUT
- 200ms (TYP)  $t_{\text{rec}}$
- WATCHDOG TIMER - 1.6sec (TYP)
- AUTOMATIC BATTERY SWITCHOVER
- LOW BATTERY SUPPLY CURRENT - 0.4 $\mu$ A (TYP)
- POWER-FAIL COMPARATOR (PFI/ $\overline{\text{PFO}}$ )
- LOW SUPPLY CURRENT - 40 $\mu$ A (TYP)
- GUARANTEED  $\overline{\text{RST}}$  (RST) ASSERTION DOWN TO  $V_{\text{CC}} = 1.0\text{V}$
- OPERATING TEMPERATURE:  
-40°C to 85°C (Industrial Grade)

Figure 1. Packages

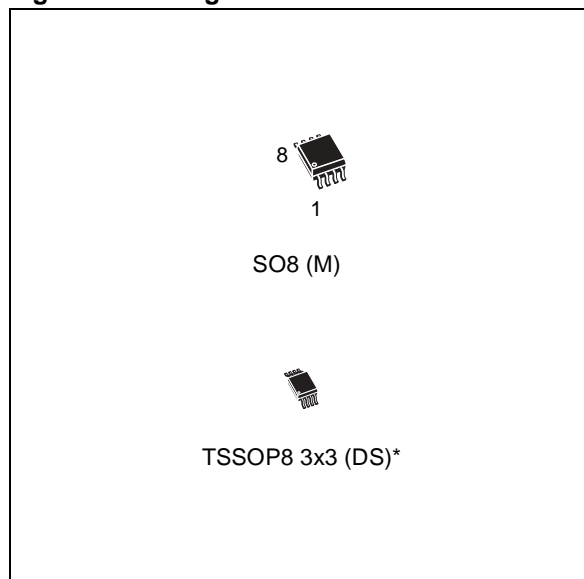


Table 1. Device Options

	Watchdog Input	Active-Low $\overline{\text{RST}}$ <sup>(1)</sup>	Active-High RST	Manual Reset Input	Battery Switch-over	Power-fail Comparator	Chip-Enable Gating
STM690T/S/R	✓	✓			✓	✓	
STM704T/S/R		✓		✓	✓	✓	
STM795T/S/R		✓ <sup>(2)</sup>			✓		✓
STM802T/S/R	✓	✓			✓	✓	
STM804T/S/R	✓		✓ <sup>(2)</sup>		✓	✓	
STM805T/S/R	✓		✓ <sup>(2)</sup>		✓	✓	
STM806T/S/R		✓		✓	✓	✓	

Note: 1. All  $\overline{\text{RST}}$  outputs push-pull (unless otherwise noted)  
2. Open drain output.

\* Contact local ST sales office for availability.

## TABLE OF CONTENTS

<b>FEATURES SUMMARY</b> .....	<b>1</b>
Figure 1. Packages.....	1
Table 1. Device Options .....	1
<b>SUMMARY DESCRIPTION</b> .....	<b>4</b>
Figure 2. Logic Diagram (STM690/802/804/805) .....	4
Figure 3. Logic Diagram (STM704/806) .....	4
Figure 4. Logic Diagram (STM795).....	4
Table 2. Signal Names .....	4
Figure 5. STM690/802/804/805 Connections .....	5
Figure 6. STM704/806 Connections.....	5
Figure 7. STM795 Connections .....	5
<b>Pin Descriptions</b> .....	<b>6</b>
Table 3. Pin Description.....	6
Figure 8. Block Diagram (STM690/802/804/805) .....	7
Figure 9. Block Diagram (STM704/806).....	7
Figure 10. Block Diagram (STM795) .....	8
Figure 11. Hardware Hookup .....	8
<b>OPERATION</b> .....	<b>9</b>
<b>Reset Output</b> .....	<b>9</b>
<b>Push-button Reset Input (STM704/806)</b> .....	<b>9</b>
<b>Watchdog Input (NOT available on STM704/795/806)</b> .....	<b>9</b>
<b>Back-up Battery Switchover</b> .....	<b>9</b>
Table 4. I/O Status in Battery Back-up .....	9
<b>Chip-Enable Gating (STM795 only)</b> .....	<b>10</b>
<b>Chip Enable Input (STM795 only)</b> .....	<b>10</b>
<b>Chip Enable Output (STM795 only)</b> .....	<b>10</b>
Figure 12. Chip-Enable Gating .....	10
Figure 13. Chip Enable Waveform (STM795) .....	10
<b>Power-fail Input/Output (NOT available on STM795)</b> .....	<b>11</b>
<b>Applications Information</b> .....	<b>11</b>
Figure 14. Power-fail Comparator Waveform (STM690/704/802/804/805/806).....	11
<b>Using a SuperCap™ as a Backup Power Source</b> .....	<b>12</b>
Figure 15. Using a SuperCap™ .....	12
<b>Negative-Going V<sub>CC</sub> Transients</b> .....	<b>12</b>
<b>TYPICAL OPERATING CHARACTERISTICS</b> .....	<b>13</b>
Figure 16. V <sub>CC</sub> -to-V <sub>OUT</sub> On-Resistance vs. Temperature .....	13
Figure 17. V <sub>BAT</sub> -to-V <sub>OUT</sub> On-Resistance vs. Temperature.....	13
Figure 18. Supply Current vs. Temperature (no load) .....	14
Figure 19. Battery Current vs. Temperature.....	14
Figure 20. V <sub>PFI</sub> Threshold vs. Temperature .....	15

Figure 21. Reset Comparator Propagation Delay vs. Temperature . . . . .	15
Figure 22. Power-up $t_{rec}$ vs. Temperature . . . . .	16
Figure 23. Normalized Reset Threshold vs. Temperature . . . . .	16
Figure 24. Watchdog Time-out Period vs. Temperature . . . . .	17
Figure 25. $\bar{E}$ to $\bar{E}_{CON}$ On-Resistance vs. Temperature . . . . .	17
Figure 26. PFI to $\overline{PFO}$ Propagation Delay vs. Temperature. . . . .	18
Figure 27. Output Voltage vs. Load Current ( $V_{CC} = 5V$ ; $V_{BAT} = 2.8V$ ; $T_A = 25^\circ C$ ). . . . .	18
Figure 28. Output Voltage vs. Load Current ( $V_{CC} = 0V$ ; $V_{BAT} = 2.8V$ ; $T_A = 25^\circ C$ ). . . . .	19
Figure 29. $\overline{RST}$ Output Voltage vs. Supply Voltage . . . . .	19
Figure 30. RST Output Voltage vs. Supply Voltage . . . . .	20
Figure 31. Power-fail Comparator Response Time (Assertion) . . . . .	20
Figure 32. Power-fail Comparator Response Time (De-Assertion) . . . . .	21
Figure 33. Maximum Transient Duration vs. Reset Threshold Overdrive. . . . .	21
Figure 34. $\bar{E}$ to $\bar{E}_{CON}$ Propagation Delay vs. Temperature . . . . .	22
<b>MAXIMUM RATING. . . . .</b>	<b>22</b>
Table 5. Absolute Maximum Ratings. . . . .	22
<b>DC and AC PARAMETERS . . . . .</b>	<b>23</b>
Table 6. Operating and AC Measurement Conditions. . . . .	23
Figure 35. $\bar{E}$ to $\bar{E}_{CON}$ Propagation Delay Test Circuit. . . . .	23
Figure 36. AC Testing Input/Output Waveforms. . . . .	23
Figure 37. $\overline{MR}$ Timing Waveform . . . . .	24
Figure 38. Watchdog Timing . . . . .	24
Table 7. DC and AC Characteristics . . . . .	24
<b>PACKAGE MECHANICAL . . . . .</b>	<b>27</b>
Figure 39. SO8 – 8-lead Plastic Small Outline, 150 mils body width, Package Mech. Drawing. . . . .	27
Table 8. SO8 – 8-lead Plastic Small Outline, 150 mils body width, Package Mechanical Data . . . . .	27
Figure 40. TSSOP8 – 8-lead, Thin Shrink Small Outline, 3x3mm body size, Outline . . . . .	28
Table 9. TSSOP8 – 8-lead, Thin Shrink Small Outline, 3x3mm body size, Mechanical Data . . . . .	28
<b>PART NUMBERING . . . . .</b>	<b>29</b>
Table 10. Ordering Information Scheme . . . . .	29
Table 11. Marking Description. . . . .	30
<b>REVISION HISTORY. . . . .</b>	<b>31</b>
Table 12. Document Revision History . . . . .	31

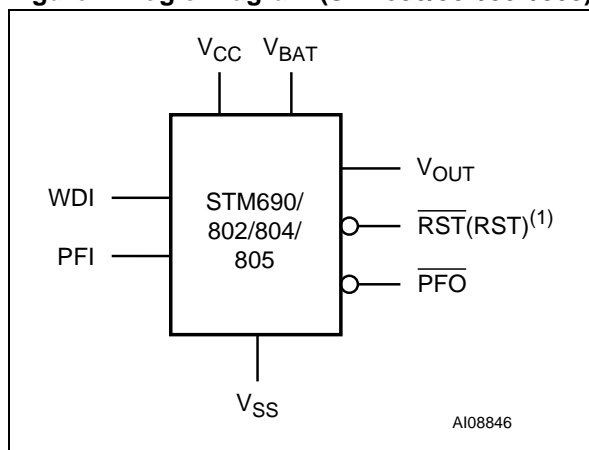
### SUMMARY DESCRIPTION

The STM690/704/795/802/804/805/806 Supervisors are self-contained devices which provide microprocessor supervisory functions with the ability to non-volatize and write-protect external LPSRAM. A precision voltage reference and comparator monitors the V<sub>CC</sub> input for an out-of-tolerance condition. When an invalid V<sub>CC</sub> condition occurs, the reset output (RST) is forced low (or high in the case of RST). These devices also offer

a watchdog timer (except for STM704/795/806) as well as a power-fail comparator (except for STM795) to provide the system with an early warning of impending power failure.

These devices are available in a standard 8-pin SOIC package or a space-saving 8-pin TSSOP package.

Figure 2. Logic Diagram (STM690/802/804/805)



Note: 1. For STM804/805, reset output is active-high and open drain.

Figure 3. Logic Diagram (STM704/806)

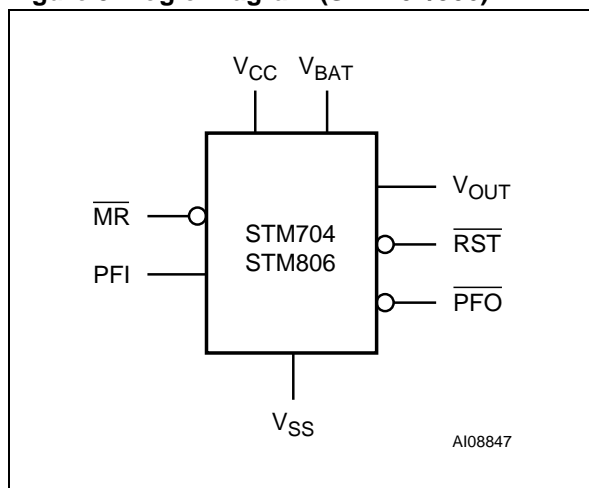


Figure 4. Logic Diagram (STM795)

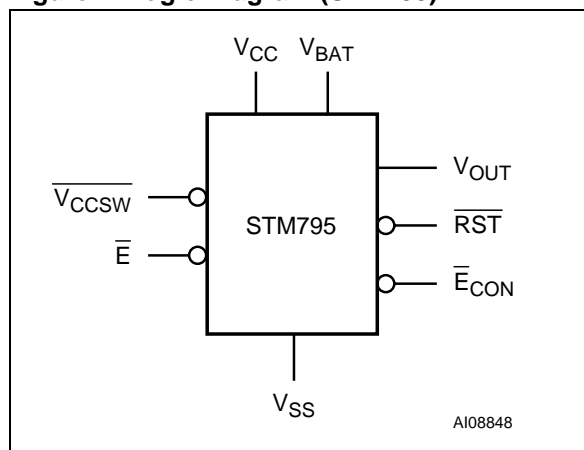
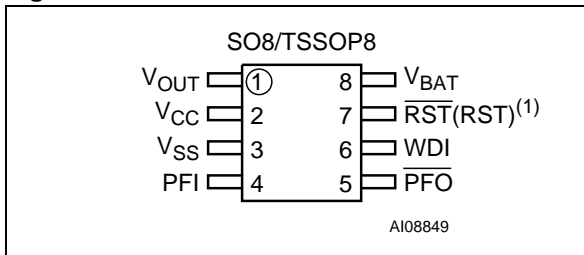


Table 2. Signal Names

$\overline{MR}$	Push-button Reset Input
WDI	Watchdog Input
$\overline{RST}$	Active-Low Reset Output
RST <sup>(1)</sup>	Active-High Reset Output
$\overline{E}^{(2)}$	Chip Enable Input
$\overline{ECON}^{(2)}$	Conditioned Chip Enable Output
$\overline{VCCSW}^{(2)}$	VCC Switch Output
V <sub>OUT</sub>	Supply Voltage Output
V <sub>CC</sub>	Supply Voltage
V <sub>BAT</sub>	Back-up Supply Voltage
PFI	Power-fail Input
$\overline{PFO}$	Power-fail Output
V <sub>SS</sub>	Ground

Note: 1. Open drain for STM804/805 only.  
2. STM795

Figure 5. STM690/802/804/805 Connections



Note: 1. For STM804/805, reset output is active-high and open drain.

Figure 6. STM704/806 Connections

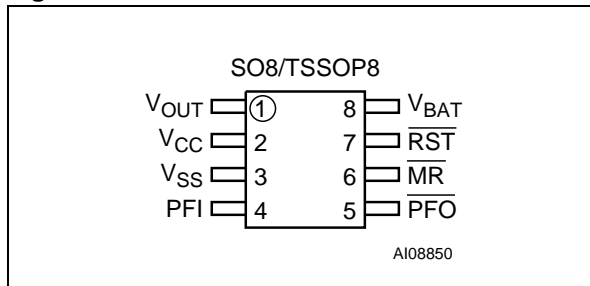
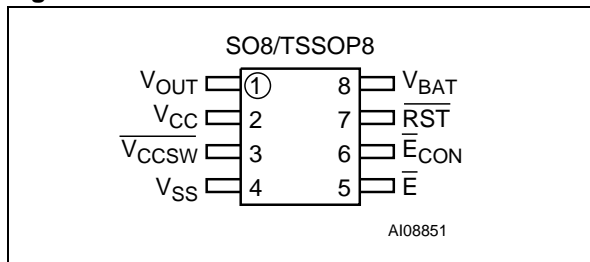


Figure 7. STM795 Connections



**Pin Descriptions**

**MR.** A logic low on /MR asserts the reset output. Reset remains asserted as long as MR is low and for  $t_{rec}$  after MR returns high. This active-low input has an internal pull-up. It can be driven from a TTL or CMOS logic line, or shorted to ground with a switch. Leave open if unused.

**WDI.** If WDI remains high or low for 1.6sec, the internal watchdog timer runs out and reset is triggered. The internal watchdog timer clears while reset is asserted or when WDI sees a rising or falling edge.

The watchdog function cannot be disabled by allowing the WDI pin to float.

**RST.** Pulses low for  $t_{rec}$  when triggered, and stays low whenever  $V_{CC}$  is below the reset threshold or when MR is a logic low. It remains low for  $t_{rec}$  after either  $V_{CC}$  rises above the reset threshold, the watchdog triggers a reset, or MR goes from low to high.

**RST (Open Drain).** Pulses high for  $t_{rec}$  when triggered, and stays high whenever  $V_{CC}$  is above the reset threshold or when MR is a logic high. It remains high for  $t_{rec}$  after either  $V_{CC}$  falls below the reset threshold, the watchdog triggers a reset, or MR goes from high to low.

**PFI.** When PFI is less than  $V_{PFI}$  or when  $V_{CC}$  falls below  $V_{SW}$  (2.4V), PFO goes low; otherwise, PFO remains high. Connect to ground if unused.

**PFO.** When PFI is less than  $V_{PFI}$ , or  $V_{CC}$  falls below  $V_{SW}$ , PFO goes low; otherwise, PFO remains high. Leave open if unused.

**VO<sub>UT</sub>.** When  $V_{CC}$  is above the switchover voltage ( $V_{SO}$ ),  $V_{OUT}$  is connected to  $V_{CC}$  through a P-channel MOSFET switch. When  $V_{CC}$  falls below  $V_{SO}$ ,  $V_{BAT}$  connects to  $V_{OUT}$ . Connect to  $V_{CC}$  if no battery is used.

**V<sub>CCSW</sub>.** When  $V_{OUT}$  switches to battery,  $\overline{V_{CCSW}}$  is high. When  $V_{OUT}$  switches back to  $V_{CC}$ ,  $V_{CCSW}$  is low. It can be used to drive gate of external PMOS transistor for  $I_{OUT}$  requirements exceeding 75mA.

**E.** The input to the chip-enable gating circuit. Connect to ground if unused.

**E<sub>CON</sub>.**  $\overline{E_{CON}}$  goes low only when E is low and reset is not asserted. If  $\overline{E_{CON}}$  is low when reset is asserted,  $\overline{E_{CON}}$  will remain low for 15µs or until E goes high, whichever occurs first. In the disabled mode,  $\overline{E_{CON}}$  is pulled up to  $V_{OUT}$ .

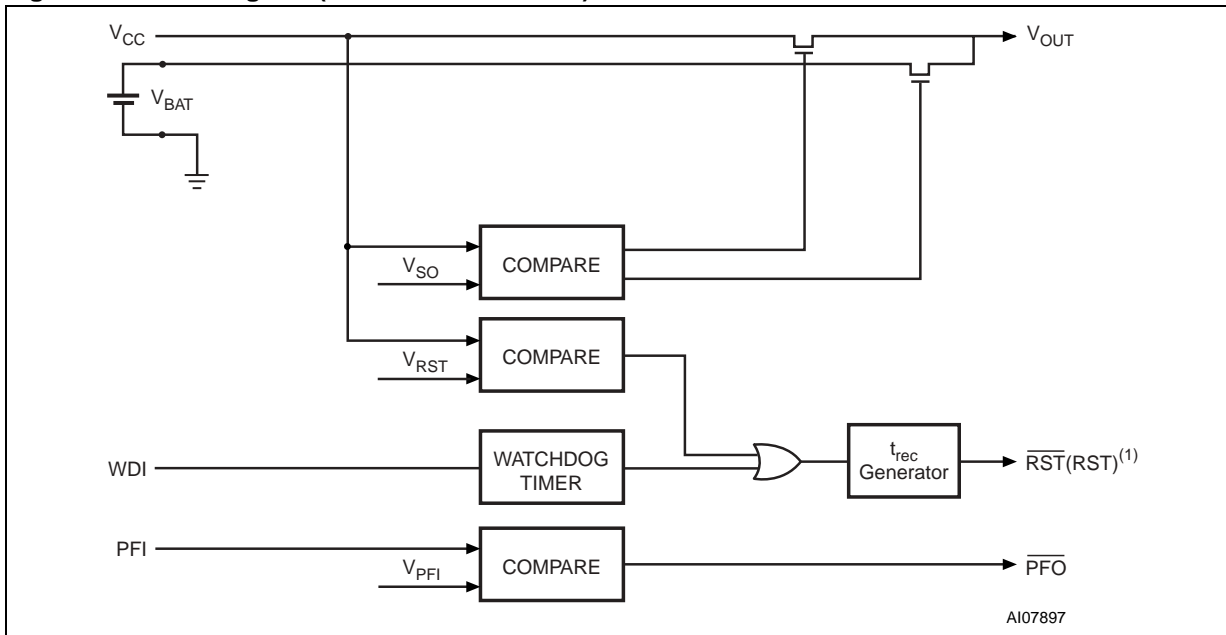
**V<sub>BAT</sub>.** When  $V_{CC}$  falls below  $V_{SO}$ ,  $V_{OUT}$  switches from  $V_{CC}$  to  $V_{BAT}$ . When  $V_{CC}$  rises above  $V_{SO}$  + hysteresis,  $V_{OUT}$  reconnects to  $V_{CC}$ .  $V_{BAT}$  may exceed  $V_{CC}$ . Connect to  $V_{CC}$  if no battery is used.

**Table 3. Pin Description**

Pin				Name	Function
STM795	STM690 STM802	STM704 STM806	STM804 STM805		
–	–	6	–	$\overline{MR}$	Push-button Reset Input
–	6	–	6	WDI	Watchdog Input
7	7	7	–	$\overline{RST}$	Active-Low Reset Output
–	–	–	7	RST	Active-High Reset Output
–	4	4	4	PFI	PFI Power-fail Input
–	5	5	5	$\overline{PFO}$	$\overline{PFO}$ Power-fail Output
1	1	1	1	$V_{OUT}$	Supply Output for External LPSRAM
2	2	2	2	$V_{CC}$	Supply Voltage
3	–	–	–	$\overline{V_{CCSW}}$	$V_{CC}$ Switch Output
4	3	3	3	$V_{SS}$	Ground
5	–	–	–	E	Chip Enable Input
6	–	–	–	$\overline{E_{CON}}$	Conditioned Chip Enable Output
8	8	8	8	$V_{BAT}$	Backup-Battery Input

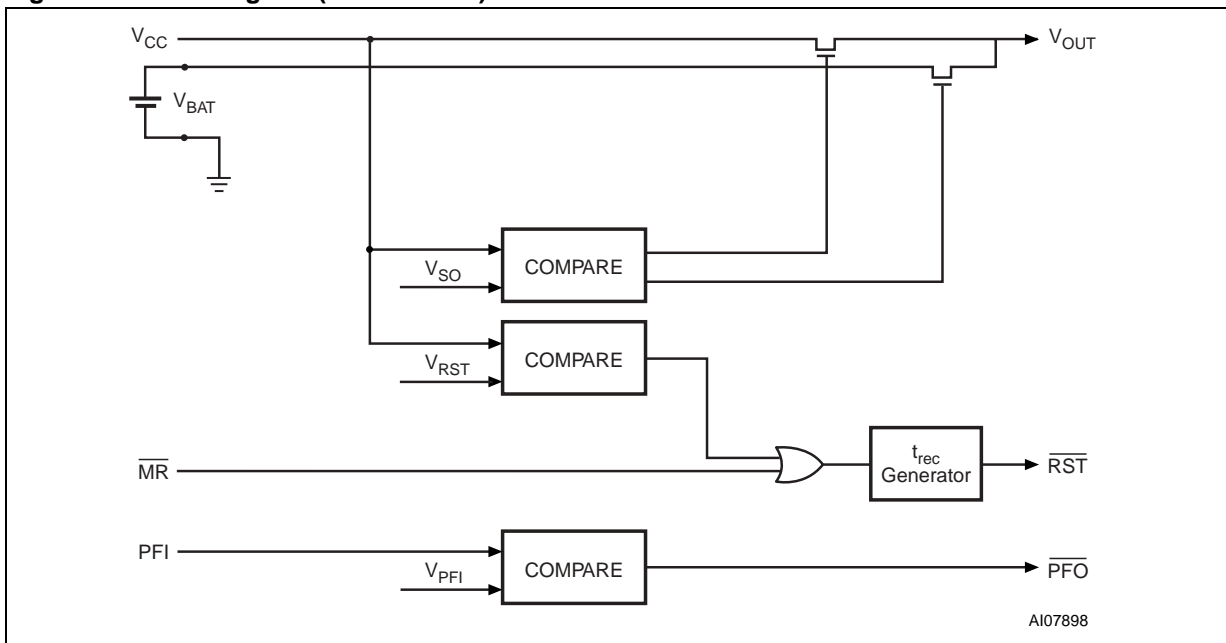


Figure 8. Block Diagram (STM690/802/804/805)



Note: 1. For STM804/805, reset output is active-high and open drain.

Figure 9. Block Diagram (STM704/806)





## OPERATION

### Reset Output

The STM690/704/795/802/804/805/806 Supervisor asserts a reset signal to the MCU whenever  $V_{CC}$  goes below the reset threshold ( $V_{RST}$ ), a watchdog time-out occurs, or when the Push-button Reset Input ( $\overline{MR}$ ) is taken low.  $RST$  is guaranteed to be a logic low (logic high for STM804/805) for  $0V < V_{CC} < V_{RST}$  if  $V_{BAT}$  is greater than 1V. Without a back-up battery,  $RST$  is guaranteed valid down to  $V_{CC} = 1V$ .

During power-up, once  $V_{CC}$  exceeds the reset threshold an internal timer keeps  $RST$  low for the reset time-out period,  $t_{rec}$ . After this interval  $RST$  returns high.

If  $V_{CC}$  drops below the reset threshold,  $\overline{RST}$  goes low. Each time  $\overline{RST}$  is asserted, it stays low for at least the reset time-out period ( $t_{rec}$ ). Any time  $V_{CC}$  goes below the reset threshold the internal timer clears. The reset timer starts when  $V_{CC}$  returns above the reset threshold.

### Push-button Reset Input (STM704/806)

A logic low on  $\overline{MR}$  asserts reset. Reset remains asserted while  $\overline{MR}$  is low, and for  $t_{rec}$  (see [Figure 37., page 24](#)) after it returns high. The  $\overline{MR}$  input has an internal 40k $\Omega$  pull-up resistor, allowing it to be left open if not used. This input can be driven with TTL/CMOS-logic levels or with open-drain/collector outputs. Connect a normally open momentary switch from  $\overline{MR}$  to GND to create a manual reset function; external debounce circuitry is not required. If  $\overline{MR}$  is driven from long cables or the device is used in a noisy environment, connect a 0.1 $\mu$ F capacitor from  $\overline{MR}$  to GND to provide additional noise immunity.  $\overline{MR}$  may float, or be tied to  $V_{CC}$  when not used.

### Watchdog Input (NOT available on STM704/795/806)

The watchdog timer can be used to detect an out-of-control MCU. If the MCU does not toggle the Watchdog Input (WDI) within  $t_{WD}$  (1.6sec typ), the reset is asserted. The internal watchdog timer is cleared by either:

1. a reset pulse, or
2. by toggling WDI (high-to-low or low-to-high), which can detect pulses as short as 50ns. If WDI is tied high or low, a reset pulse is triggered every 1.8sec ( $t_{WD} + t_{rec}$ ).

The timer remains cleared and does not count for as long as reset is asserted. As soon as reset is released, the timer starts counting (see [Figure 38., page 24](#)).

**Note:** Input frequency greater than 20ns (50MHz) will be filtered.

### Back-up Battery Switchover

In the event of a power failure, it may be necessary to preserve the contents of external SRAM through  $V_{OUT}$ . With a backup battery installed with voltage  $V_{BAT}$ , the devices automatically switch the SRAM to the back-up supply when  $V_{CC}$  falls.

**Note:** If back-up battery is not used, connect both  $V_{BAT}$  and  $V_{OUT}$  to  $V_{CC}$ .

This family of Supervisors does not always connect  $V_{BAT}$  to  $V_{OUT}$  when  $V_{BAT}$  is greater than  $V_{CC}$ .  $V_{BAT}$  connects to  $V_{OUT}$  (through a 100 $\Omega$  switch) when  $V_{CC}$  is below  $V_{SW}$  (2.4V) or  $V_{BAT}$  (whichever is lower). This is done to allow the back-up battery (e.g., a 3.6V lithium cell) to have a higher voltage than  $V_{CC}$ .

Assuming that  $V_{BAT} > 2.0V$ , switchover at  $V_{SO}$  ensures that battery back-up mode is entered before  $V_{OUT}$  gets too close to the 2.0V minimum required to reliably retain data in most external SRAMs. When  $V_{CC}$  recovers, hysteresis is used to avoid oscillation around the  $V_{SO}$  point.  $V_{OUT}$  is connected to  $V_{CC}$  through a 3 $\Omega$  PMOS power switch.

**Note:** The back-up battery may be removed while  $V_{CC}$  is valid, assuming  $V_{BAT}$  is adequately decoupled (0.1 $\mu$ F typ), without danger of triggering a reset.

**Table 4. I/O Status in Battery Back-up**

Pin	Status
$V_{OUT}$	Connected to $V_{BAT}$ through internal switch
$V_{CC}$	Disconnected from $V_{OUT}$
PFI	Disabled
$\overline{PFO}$	Logic Low
$\overline{E}$	High impedance
$\overline{ECON}$	Logic High
WDI	Watchdog timer is disabled
$\overline{MR}$	Disabled
$\overline{RST}$	Logic Low
RST	Logic High
$V_{BAT}$	Connected to $V_{OUT}$
$\overline{VCCSW}$	Logic High (STM795)

**Chip-Enable Gating (STM795 only)**

Internal gating of the chip enable ( $\bar{E}$ ) signal prevents erroneous data from corrupting the external CMOS RAM in the event of an undervoltage condition. The STM795 uses a series transmission gate from  $\bar{E}$  to  $\bar{E}_{CON}$  (see Figure 12). During normal operation (reset not asserted), the  $\bar{E}$  transmission gate is enabled and passes all  $\bar{E}$  transitions. When reset is asserted, this path becomes disabled, preventing erroneous data from corrupting the CMOS RAM. The short  $\bar{E}$  propagation delay from  $\bar{E}$  to  $\bar{E}_{CON}$  enables the STM795 to be used with most  $\mu$ Ps. If  $\bar{E}$  is low when reset asserts,  $\bar{E}_{CON}$  remains low for typically 10 $\mu$ s to permit the current WRITE cycle to complete.

**Chip Enable Input (STM795 only)**

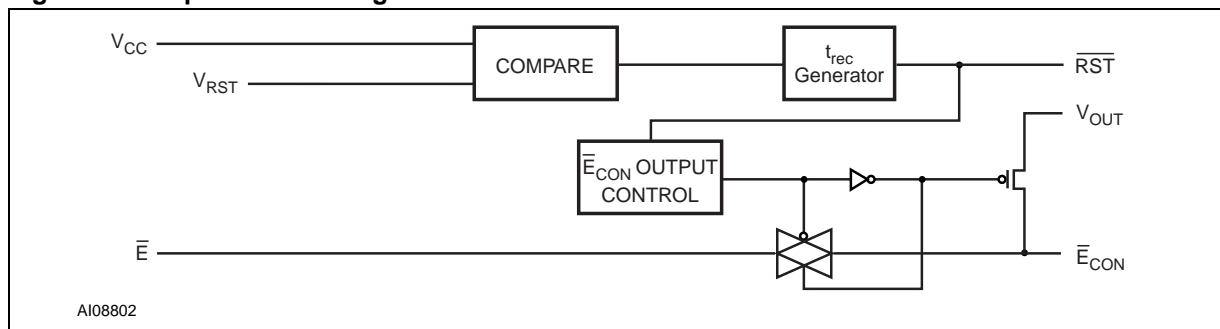
The chip-enable transmission gate is disabled and  $\bar{E}$  is high impedance (disabled mode) while reset is asserted. During a power-down sequence when  $V_{CC}$  passes the reset threshold, the chip-enable transmission gate disables and  $\bar{E}$  immediately becomes high impedance if the voltage at  $\bar{E}$  is high. If  $\bar{E}$  is low when reset asserts, the chip-enable transmission gate will disable 10 $\mu$ s after reset asserts (see Figure 13). This permits the current WRITE cycle to complete during power-down.

Any time a reset is generated, the chip-enable transmission gate remains disabled and  $\bar{E}$  remains high impedance (regardless of  $\bar{E}$  activity) for the first half of the reset time-out period ( $t_{rec}/2$ ). When the chip enable transmission gate is enabled, the impedance of  $\bar{E}$  appears as a 40 $\Omega$  resistor in series with the load at  $\bar{E}_{CON}$ . The propagation delay through the chip-enable transmission gate depends on  $V_{CC}$ , the source impedance of the drive connected to  $\bar{E}$ , and the loading on  $\bar{E}_{CON}$ . The chip enable propagation delay is production tested from the 50% point on  $\bar{E}$  to the 50% point on  $\bar{E}_{CON}$  using a 50 $\Omega$  driver and a 50pF load capacitance (see Figure 36., page 23). For minimum propagation delay, minimize the capacitive load at  $\bar{E}_{CON}$  and use a low-output impedance driver.

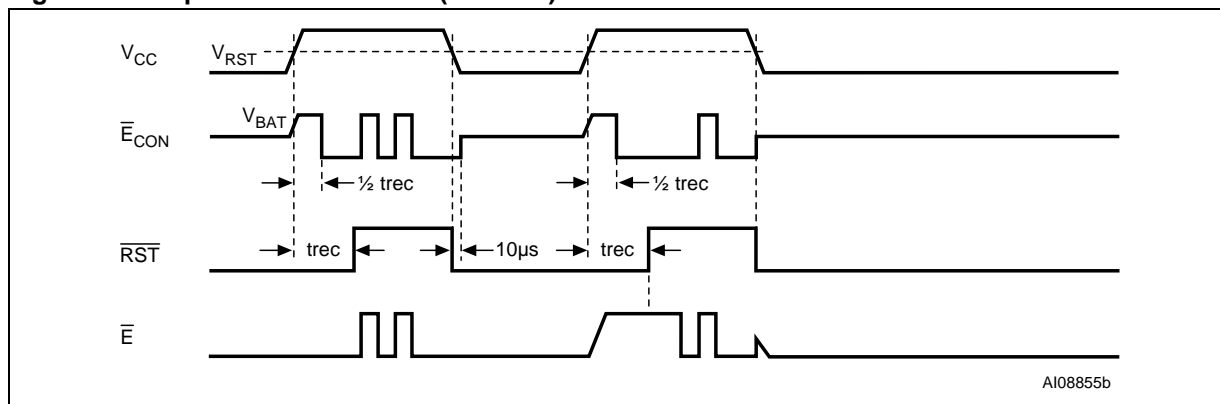
**Chip Enable Output (STM795 only)**

When the chip-enable transmission gate is enabled, the impedance of  $\bar{E}_{CON}$  is equivalent to a 40 $\Omega$  resistor in series with the source driving  $\bar{E}$ . In the disabled mode, the transmission gate is off and an active pull-up connects  $\bar{E}_{CON}$  to  $V_{OUT}$  (see Figure 12). This pull-up turns off when the transmission gate is enabled.

**Figure 12. Chip-Enable Gating**



**Figure 13. Chip Enable Waveform (STM795)**



**Power-fail Input/Output (NOT available on STM795)**

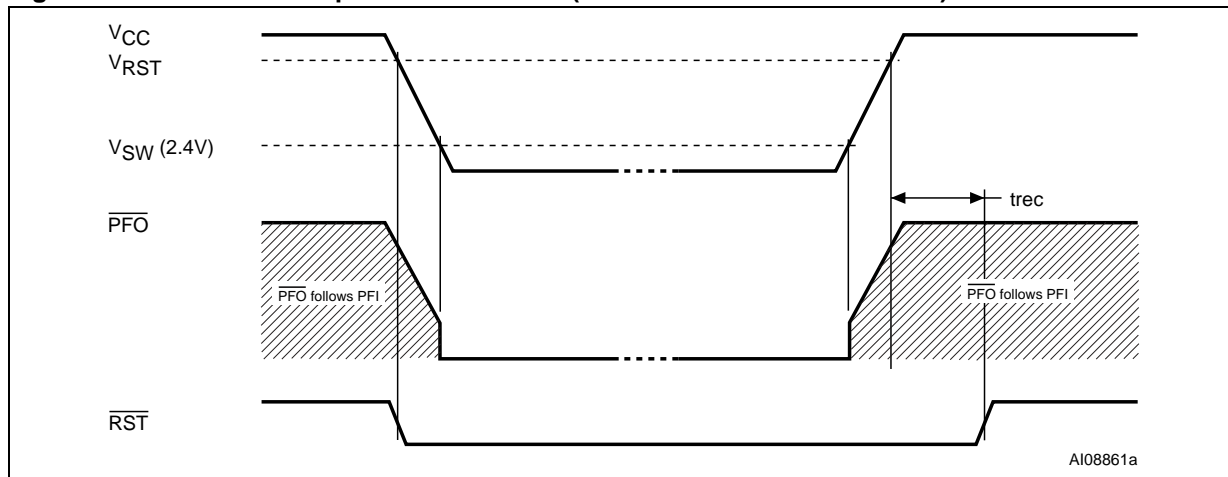
The Power-fail Input (PFI) is compared to an internal reference voltage (independent from the  $V_{RST}$  comparator). If PFI is less than the power-fail threshold ( $V_{PFI}$ ), the Power-Fail Output ( $\overline{PFO}$ ) will go low. This function is intended for use as an undervoltage detector to signal a failing power supply. Typically PFI is connected through an external voltage divider (see Figure 11., page 8) to either the unregulated DC input (if it is available) or the regulated output of the  $V_{CC}$  regulator. The voltage divider can be set up such that the voltage at PFI falls below  $V_{PFI}$  several milliseconds before the regulated  $V_{CC}$  input to the STM690/704/795/802/804/805/806 or the microprocessor drops below the minimum operating voltage.

During battery back-up, the power-fail comparator is turned off and  $\overline{PFO}$  goes (or remains) low (see

Figure 14., page 11). This occurs after  $V_{CC}$  drops below  $V_{SW}$  (2.4V). When power returns, the power-fail comparator is enabled and  $\overline{PFO}$  follows PFI. If the comparator is unused, PFI should be connected to  $V_{SS}$  and  $\overline{PFO}$  left unconnected.  $\overline{PFO}$  may be connected to  $\overline{MR}$  on the STM704/806 so that a low voltage on PFI will generate a reset output.

**Applications Information**

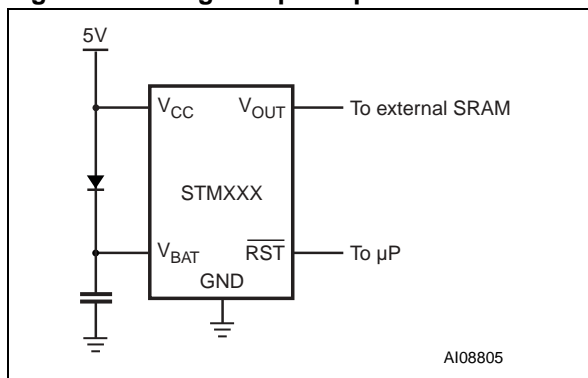
These Supervisor circuits are not short-circuit protected. Shorting  $V_{OUT}$  to ground - excluding power-up transients such as charging a decoupling capacitor - destroys the device. Decouple both  $V_{CC}$  and  $V_{BAT}$  pins to ground by placing 0.1 $\mu$ F capacitors as close to the device as possible.

**Figure 14. Power-fail Comparator Waveform (STM690/704/802/804/805/806)**

**Using a SuperCap™ as a Backup Power Source**

SuperCaps™ are capacitors with extremely high capacitance values (e.g., order of 0.47F) for their size. Figure 15 shows how to use a SuperCap as a back-up power source. The SuperCap may be connected through a diode to the V<sub>CC</sub> supply. Since V<sub>BAT</sub> can exceed V<sub>CC</sub> while V<sub>CC</sub> is above the reset threshold, there are no special precautions when using these supervisors with a Super-Cap.

**Figure 15. Using a SuperCap™**



**Negative-Going V<sub>CC</sub> Transients**

The STM690/704/795/802/804/805/806 Supervisors are relatively immune to negative-going V<sub>CC</sub> transients (glitches). Figure 33., page 21 was generated using a negative pulse applied to V<sub>CC</sub>, starting at V<sub>RST</sub> + 0.3V and ending below the reset threshold by the magnitude indicated (comparator overdrive). The graph indicates the maximum pulse width a negative V<sub>CC</sub> transient can have without causing a reset pulse. As the magnitude of the transient increases (further below the threshold), the maximum allowable pulse width decreases. Any combination of duration and overdrive which lies under the curve will NOT generate a reset signal. Typically, a V<sub>CC</sub> transient that goes 100mV below the reset threshold and lasts 40μs or less will not cause a reset pulse. A 0.1μF bypass capacitor mounted as close as possible to the V<sub>CC</sub> pin provides additional transient immunity.

### TYPICAL OPERATING CHARACTERISTICS

Note: Typical values are at  $T_A = 25^\circ\text{C}$ .

Figure 16.  $V_{CC}$ -to- $V_{OUT}$  On-Resistance vs. Temperature

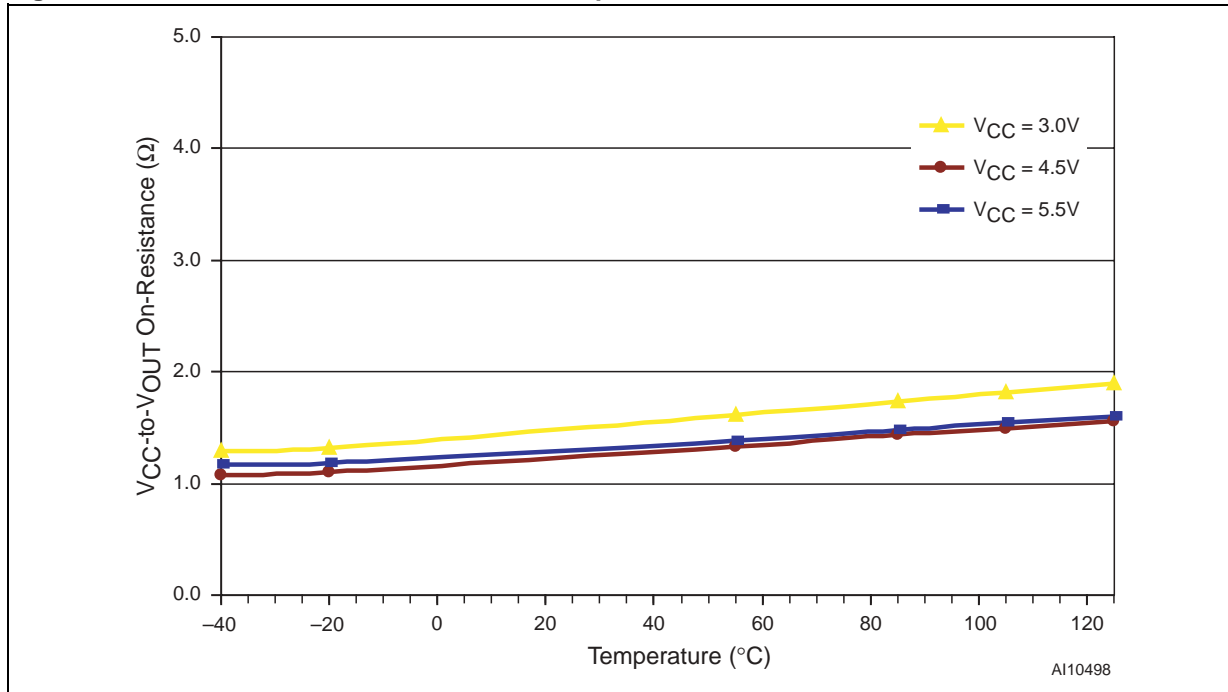


Figure 17.  $V_{BAT}$ -to- $V_{OUT}$  On-Resistance vs. Temperature

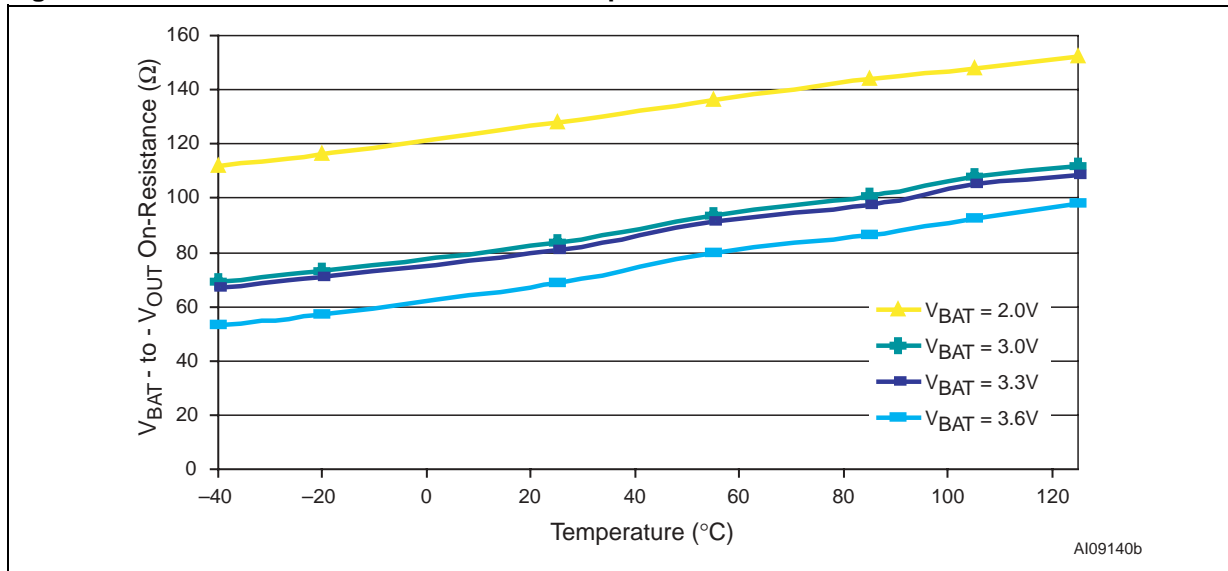


Figure 18. Supply Current vs. Temperature (no load)

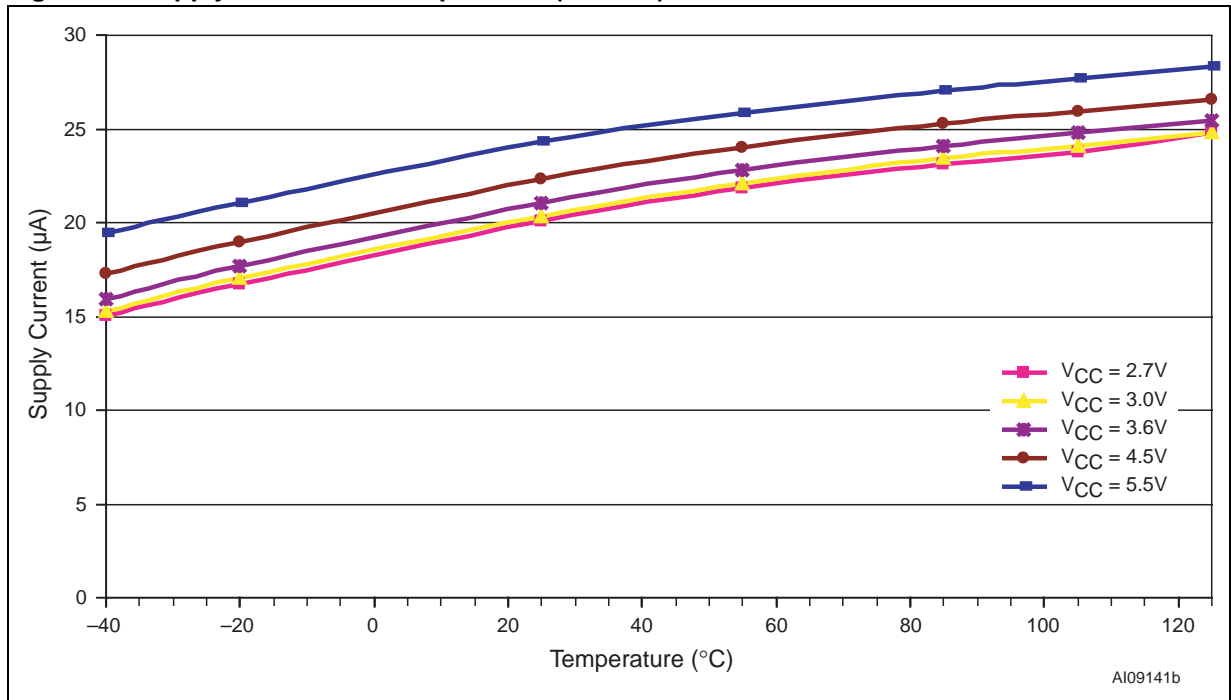


Figure 19. Battery Current vs. Temperature

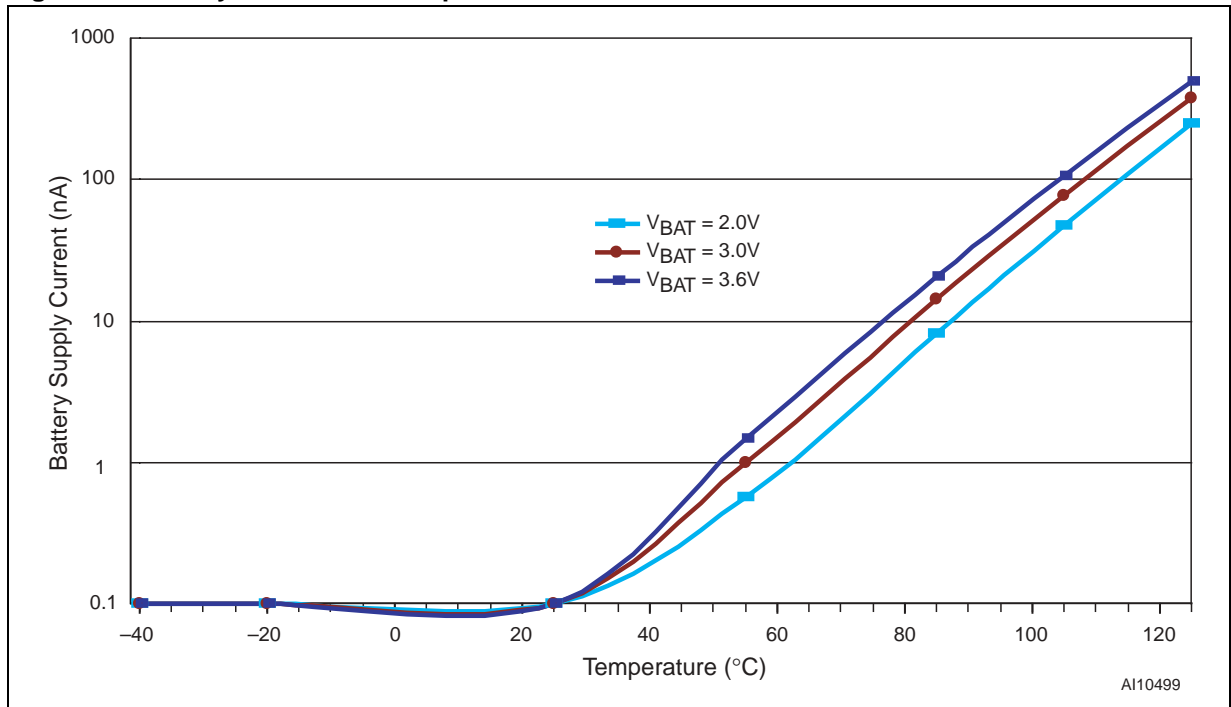


Figure 20. V<sub>PFI</sub> Threshold vs. Temperature

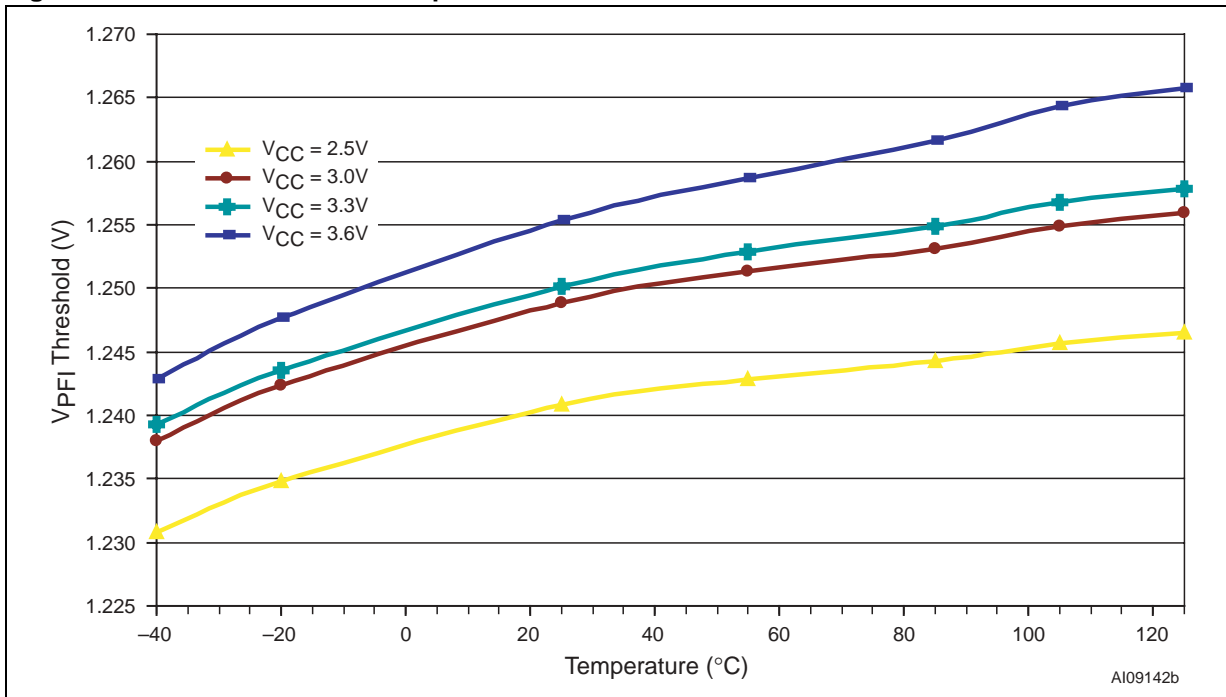


Figure 21. Reset Comparator Propagation Delay vs. Temperature

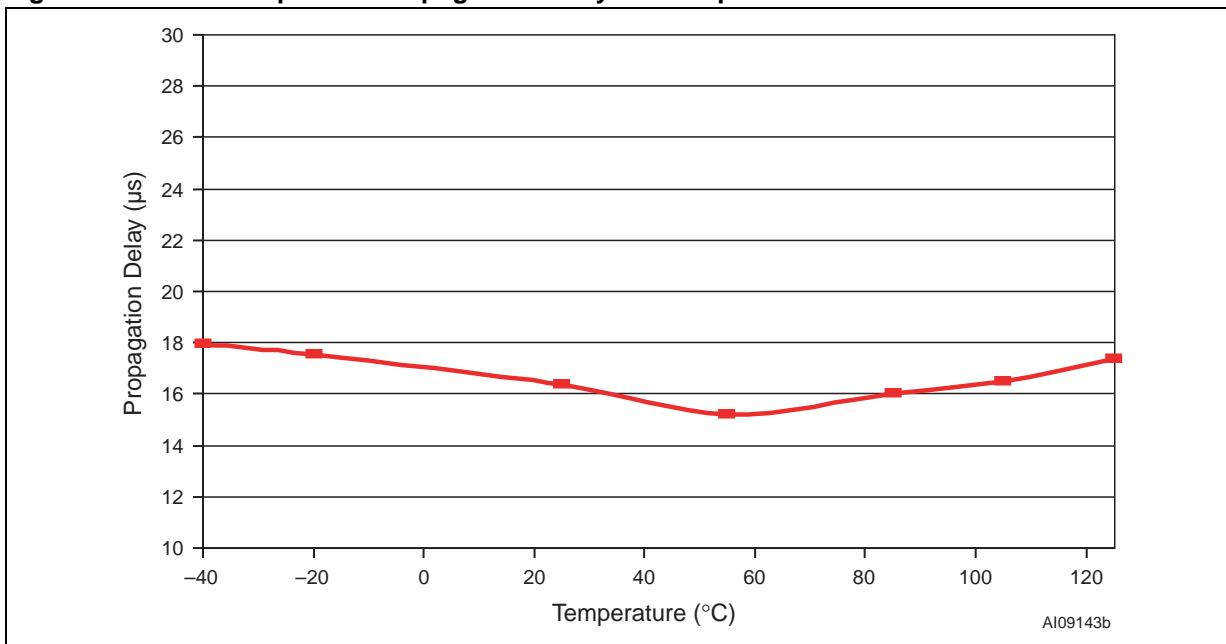


Figure 22. Power-up  $t_{rec}$  vs. Temperature

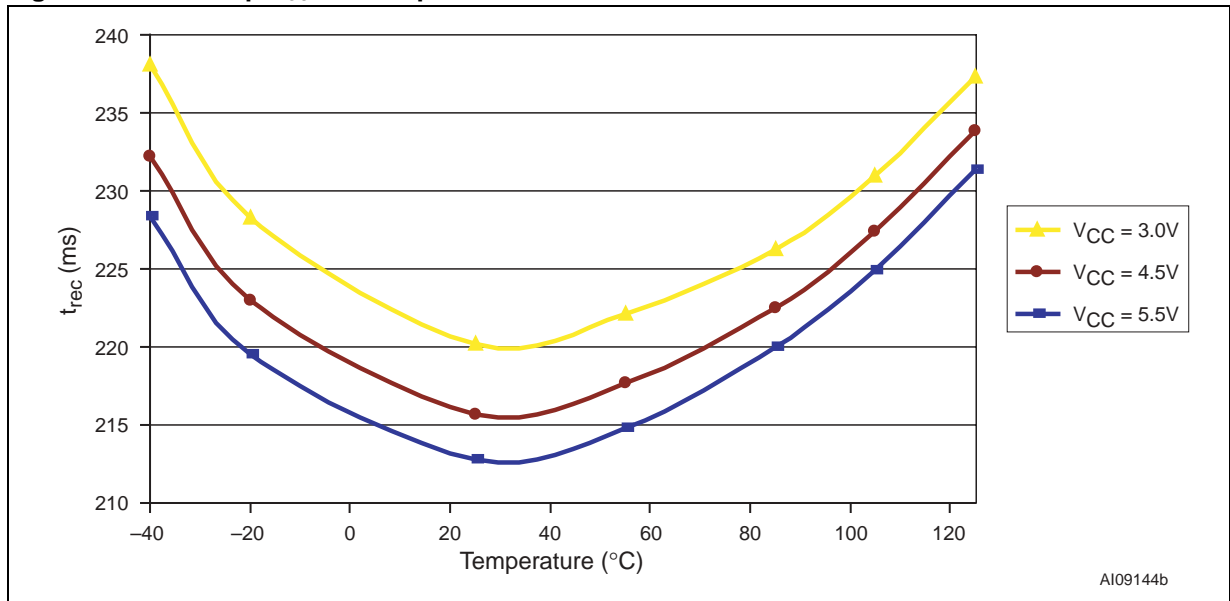


Figure 23. Normalized Reset Threshold vs. Temperature

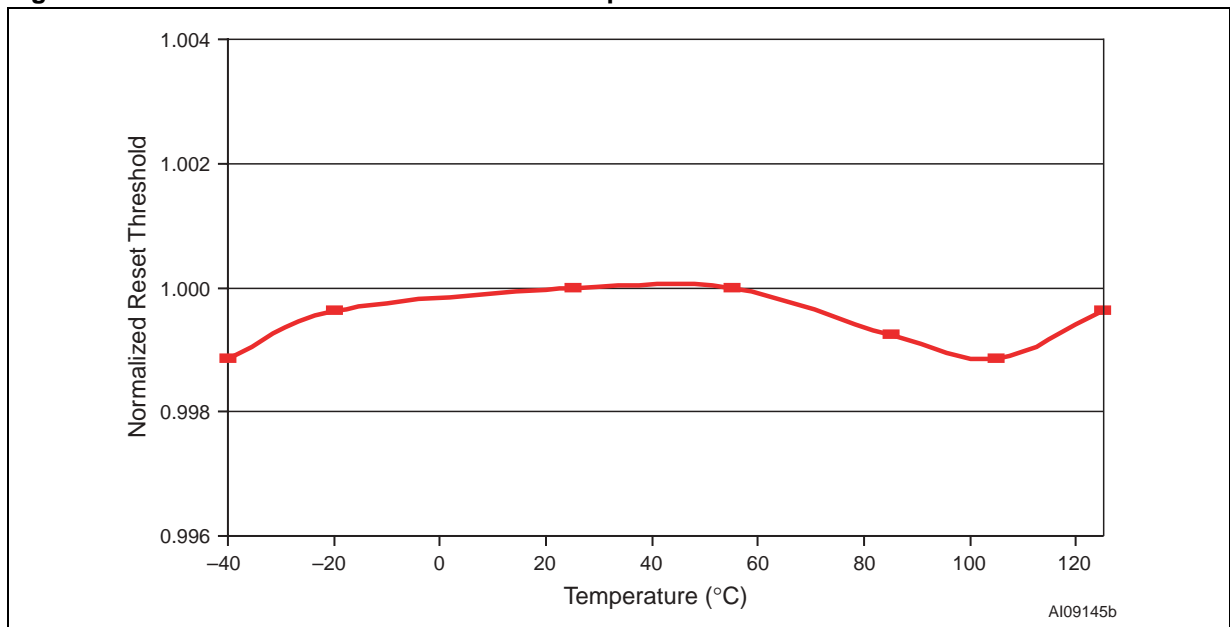


Figure 24. Watchdog Time-out Period vs. Temperature

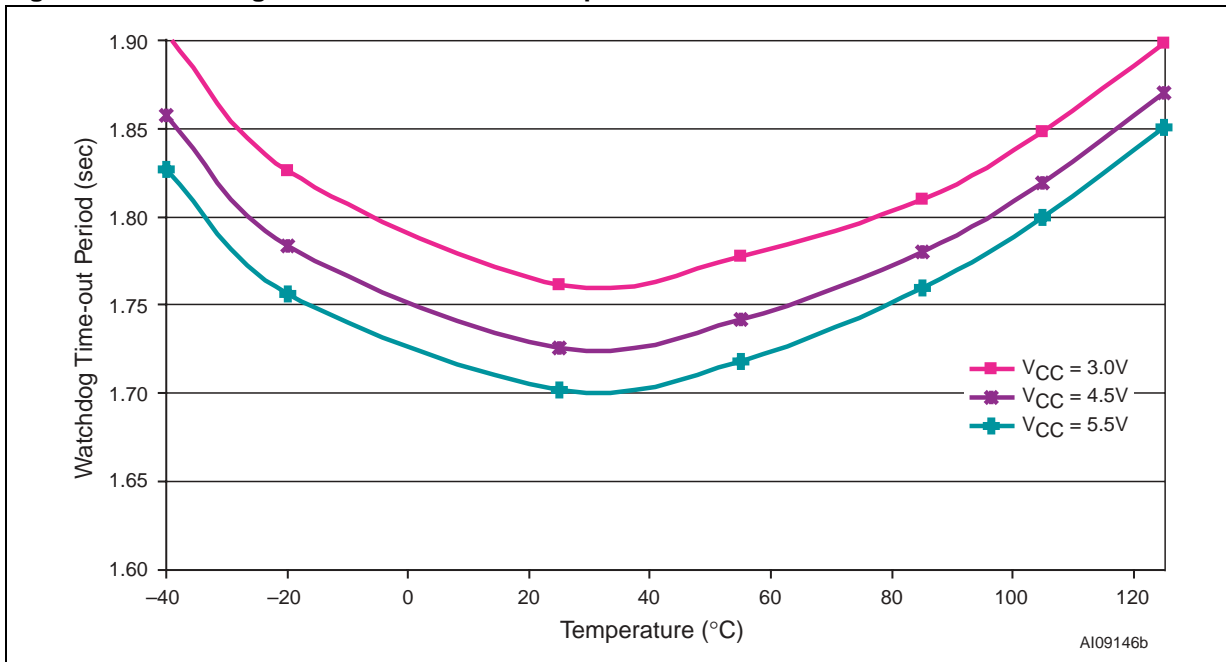


Figure 25.  $\bar{E}$  to  $\bar{E}_{CON}$  On-Resistance vs. Temperature

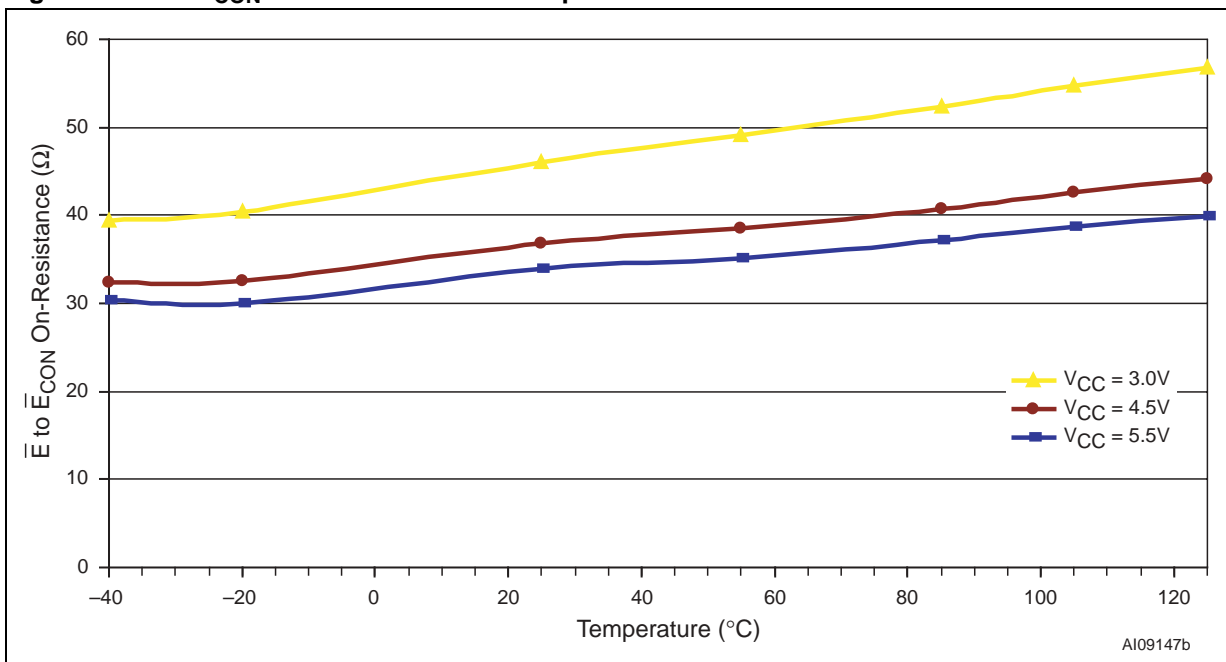


Figure 26. PFI to  $\overline{\text{PFO}}$  Propagation Delay vs. Temperature

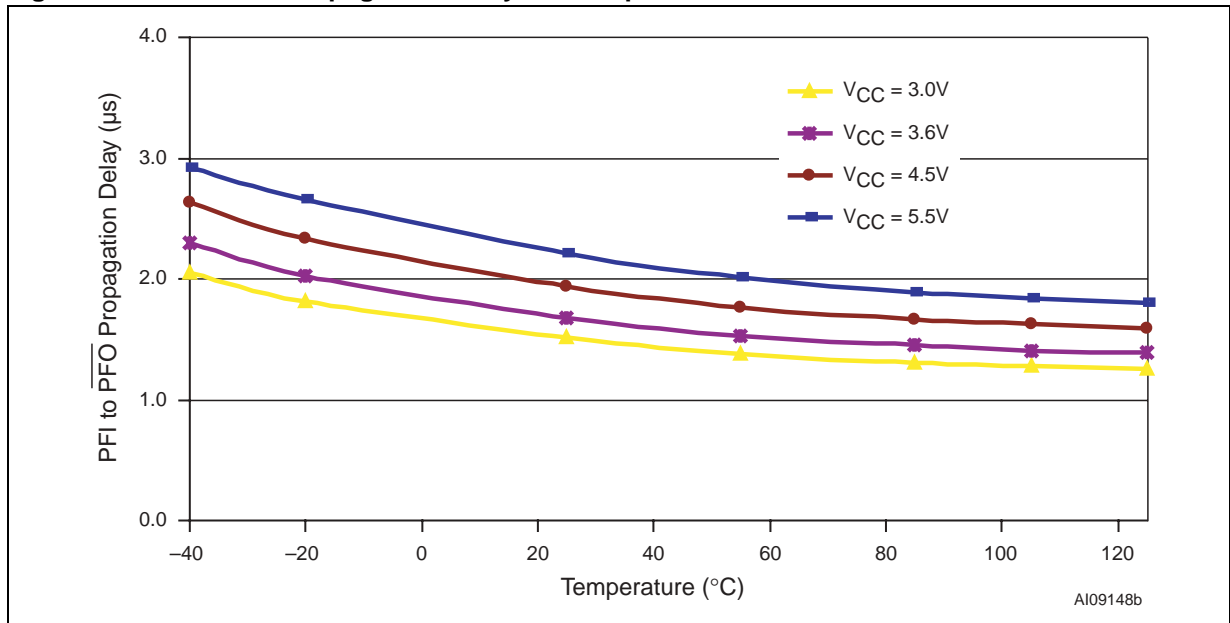


Figure 27. Output Voltage vs. Load Current (V<sub>CC</sub> = 5V; V<sub>BAT</sub> = 2.8V; T<sub>A</sub> = 25°C)

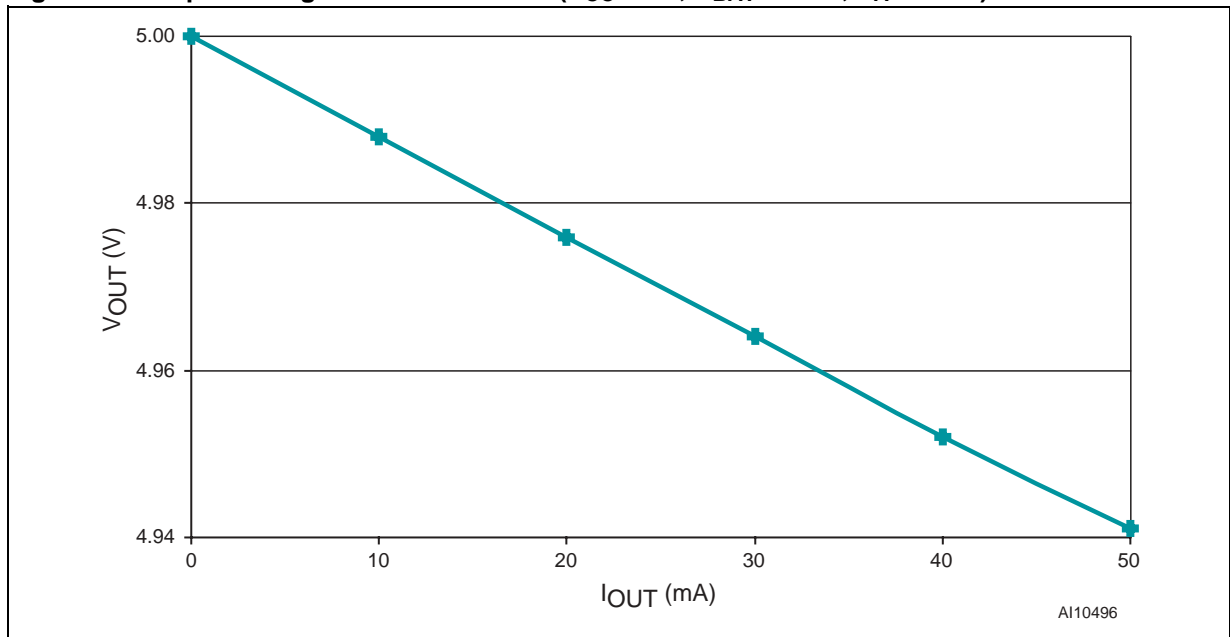


Figure 28. Output Voltage vs. Load Current ( $V_{CC} = 0V$ ;  $V_{BAT} = 2.8V$ ;  $T_A = 25^\circ C$ )

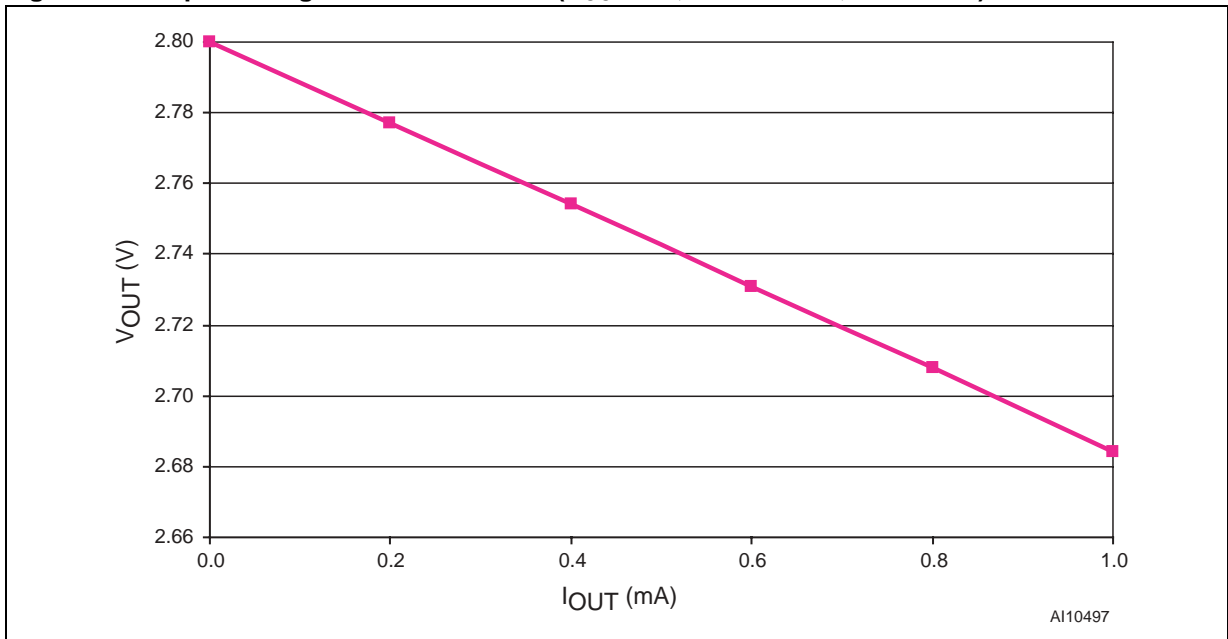


Figure 29.  $\overline{RST}$  Output Voltage vs. Supply Voltage

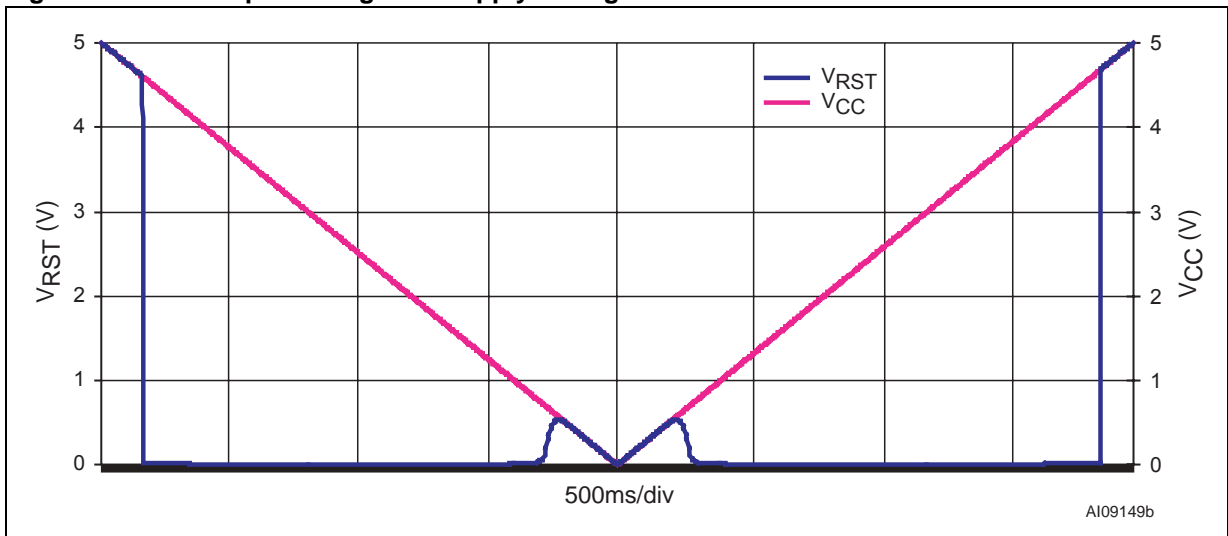


Figure 30. RST Output Voltage vs. Supply Voltage

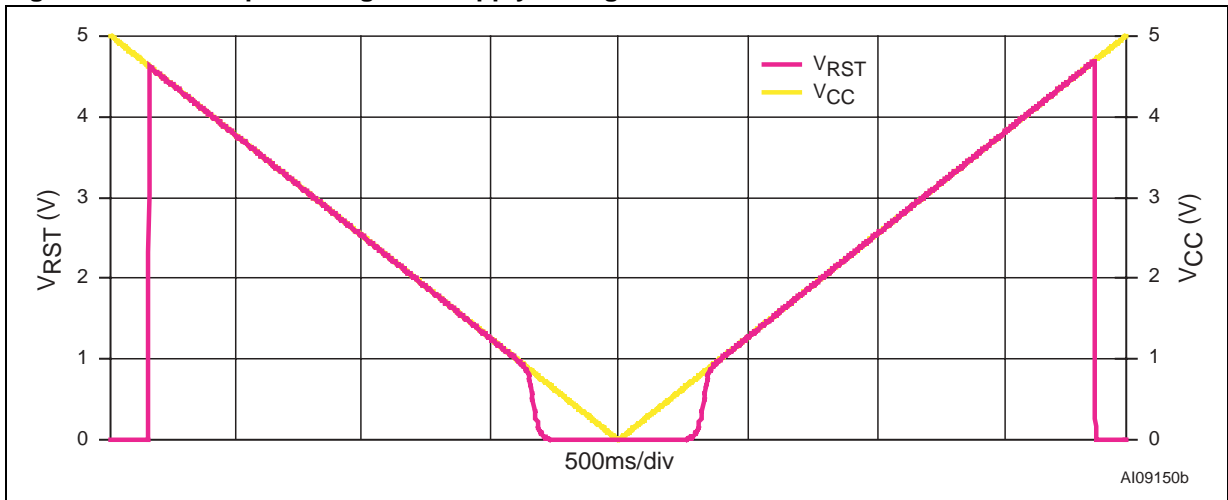


Figure 31. Power-fail Comparator Response Time (Assertion)

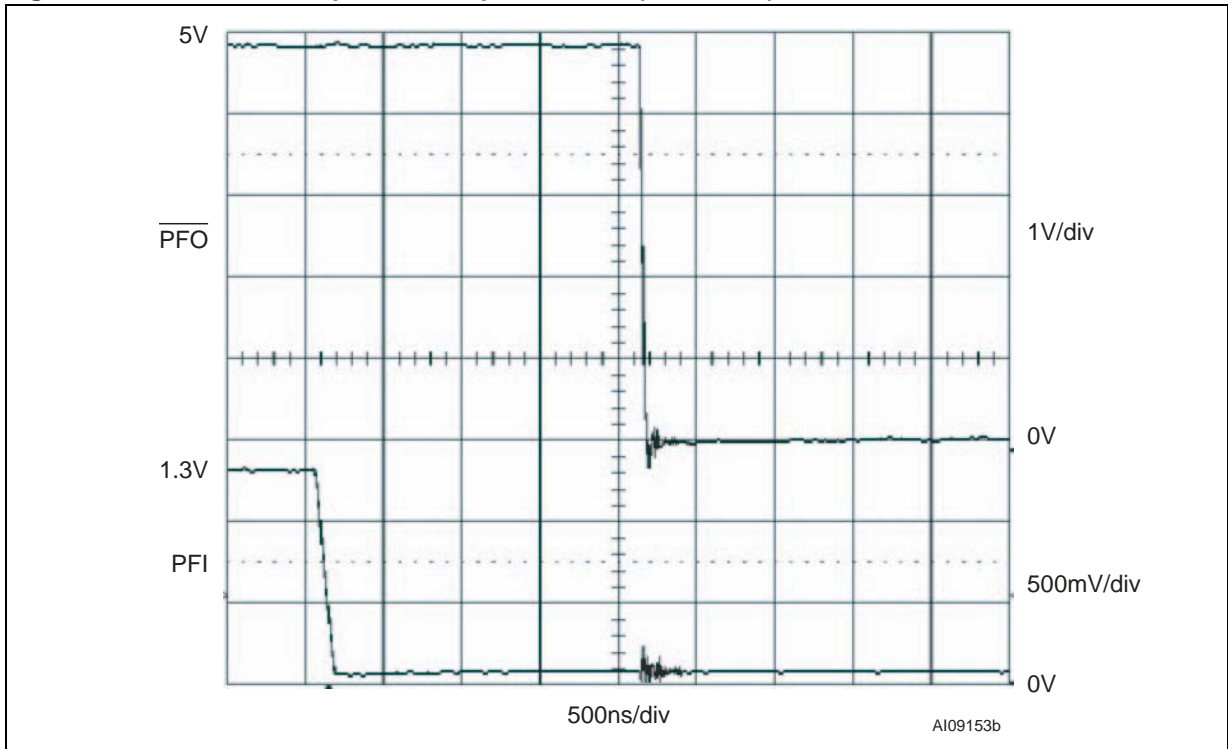


Figure 32. Power-fail Comparator Response Time (De-Assertion)

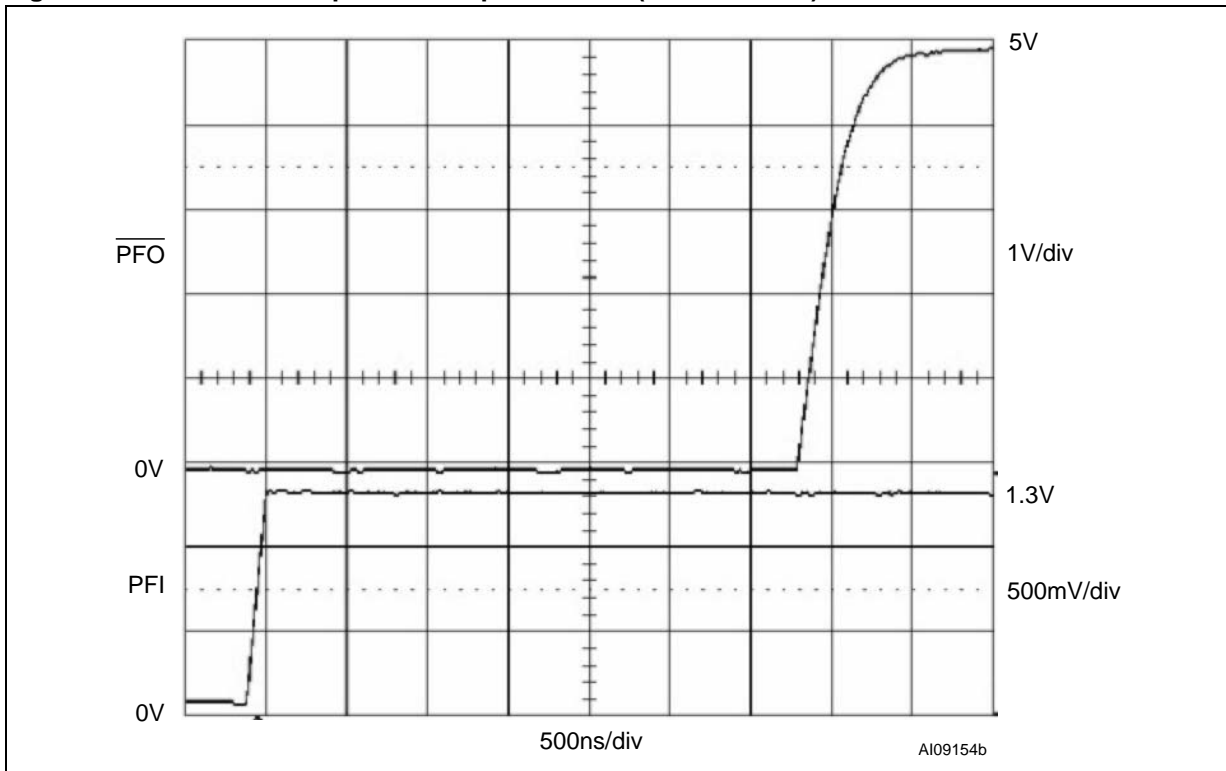


Figure 33. Maximum Transient Duration vs. Reset Threshold Overdrive

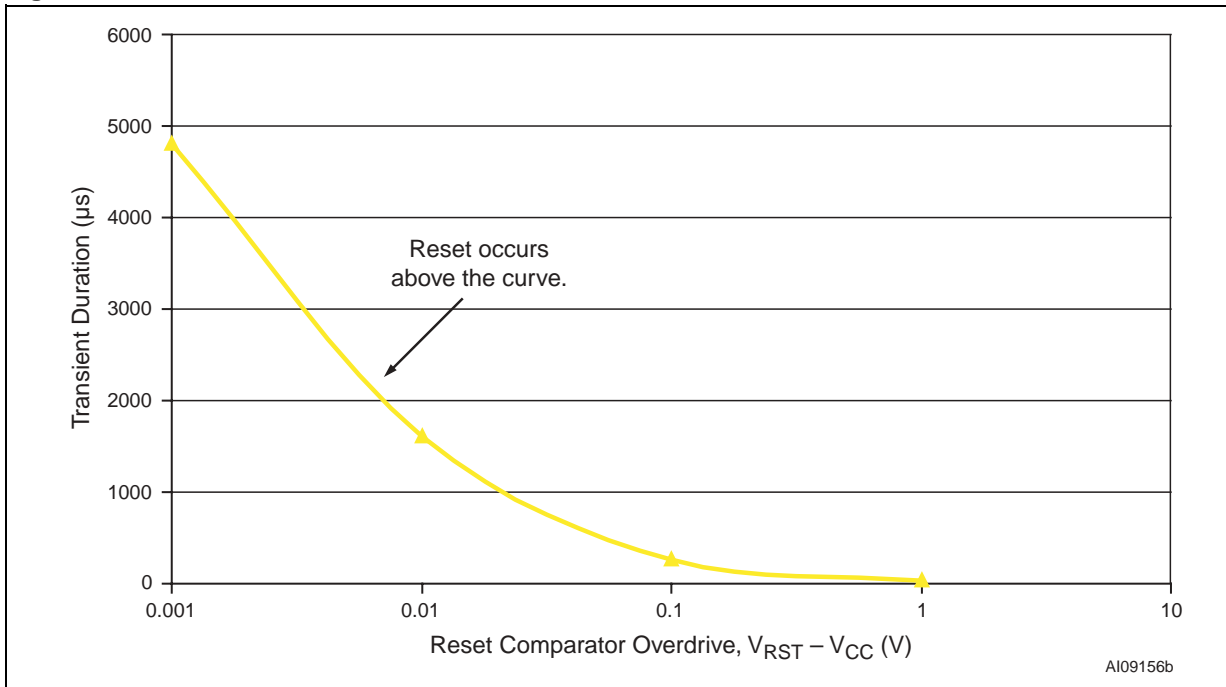
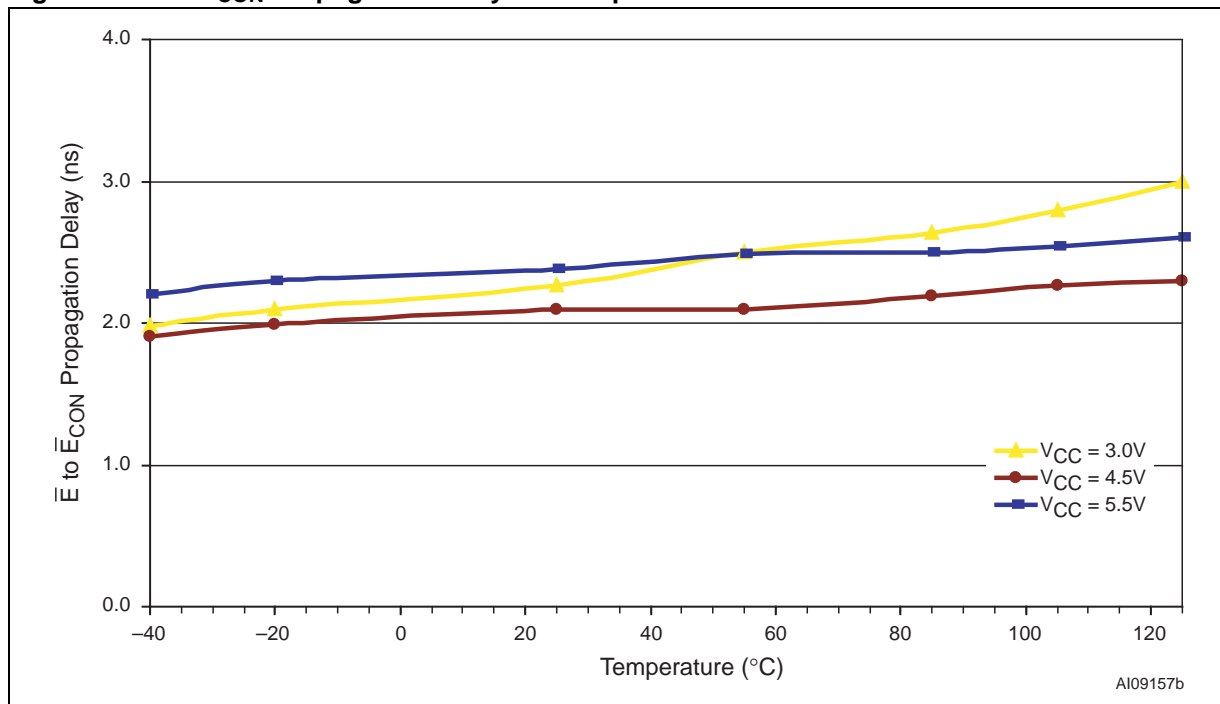


Figure 34.  $\bar{E}$  to  $\bar{E}_{CON}$  Propagation Delay vs. Temperature



### MAXIMUM RATING

Stressing the device above the rating listed in the Absolute Maximum Ratings table may cause permanent damage to the device. These are stress ratings only and operation of the device at these or any other conditions above those indicated in the Operating sections of this specification is not im-

plied. Exposure to Absolute Maximum Rating conditions for extended periods may affect device reliability. Refer also to the STMicroelectronics SURE Program and other relevant quality documents.

Table 5. Absolute Maximum Ratings

Symbol	Parameter	Value	Unit
T <sub>STG</sub>	Storage Temperature (V <sub>CC</sub> Off)	-55 to 150	°C
T <sub>SLD</sub> <sup>(1)</sup>	Lead Solder Temperature for 10 seconds	260	°C
V <sub>IO</sub>	Input or Output Voltage	-0.3 to V <sub>CC</sub> + 0.3	V
V <sub>CC</sub> /V <sub>BAT</sub>	Supply Voltage	-0.3 to 6.0	V
I <sub>O</sub>	Output Current	20	mA
P <sub>D</sub>	Power Dissipation	320	mW

Note: 1. Reflow at peak temperature of 255°C to 260°C for < 30 seconds (total thermal budget not to exceed 180°C for between 90 to 150 seconds).

### DC AND AC PARAMETERS

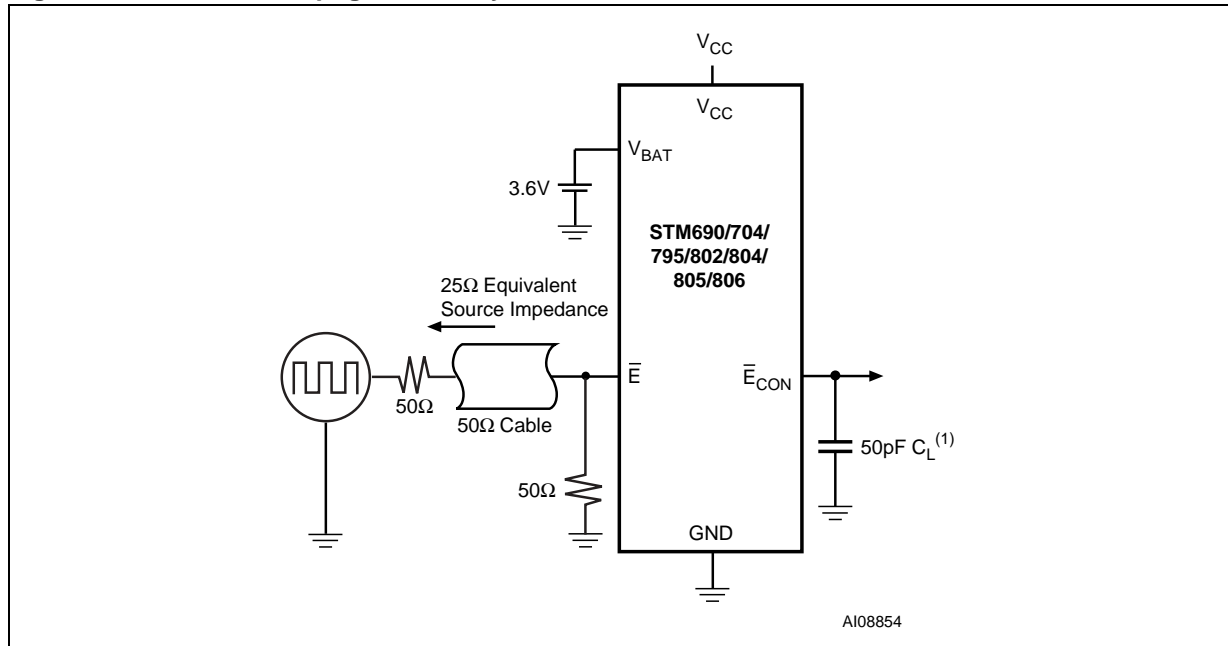
This section summarizes the operating measurement conditions, and the DC and AC characteristics of the device. The parameters in the DC and AC characteristics Tables that follow, are derived from tests performed under the Measurement

Conditions summarized in Table 6, Operating and AC Measurement Conditions. Designers should check that the operating conditions in their circuit match the operating conditions when relying on the quoted parameters.

**Table 6. Operating and AC Measurement Conditions**

Parameter	STM690/704/795/802/804/805/806	Unit
V <sub>CC</sub> /V <sub>BAT</sub> Supply Voltage	1.0 to 5.5	V
Ambient Operating Temperature (T <sub>A</sub> )	-40 to 85	°C
Input Rise and Fall Times	≤ 5	ns
Input Pulse Voltages	0.2 to 0.8V <sub>CC</sub>	V
Input and Output Timing Ref. Voltages	0.3 to 0.7V <sub>CC</sub>	V

**Figure 35.  $\bar{E}$  to  $\bar{E}_{CON}$  Propagation Delay Test Circuit**



Note: 1. C<sub>L</sub> includes load capacitance and scope probe capacitance.

**Figure 36. AC Testing Input/Output Waveforms**

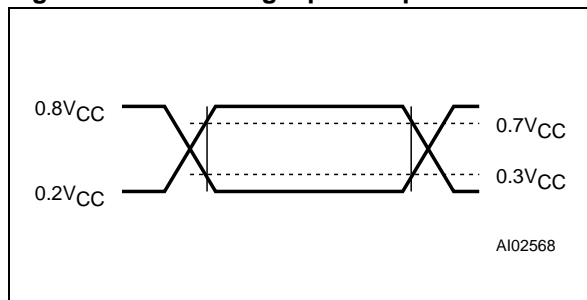
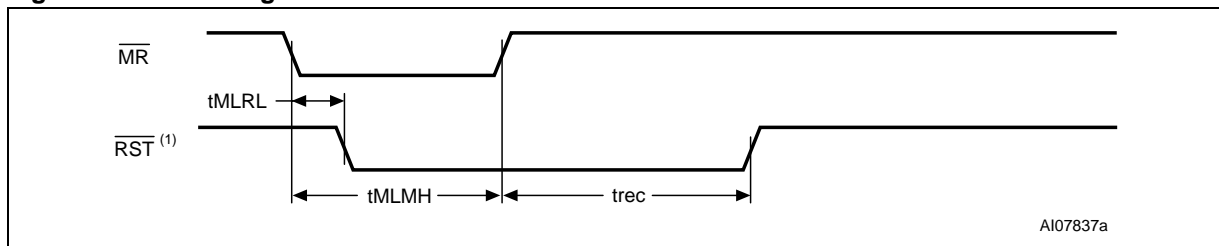


Figure 37. MR Timing Waveform



Note: 1. RST for STM805.

Figure 38. Watchdog Timing

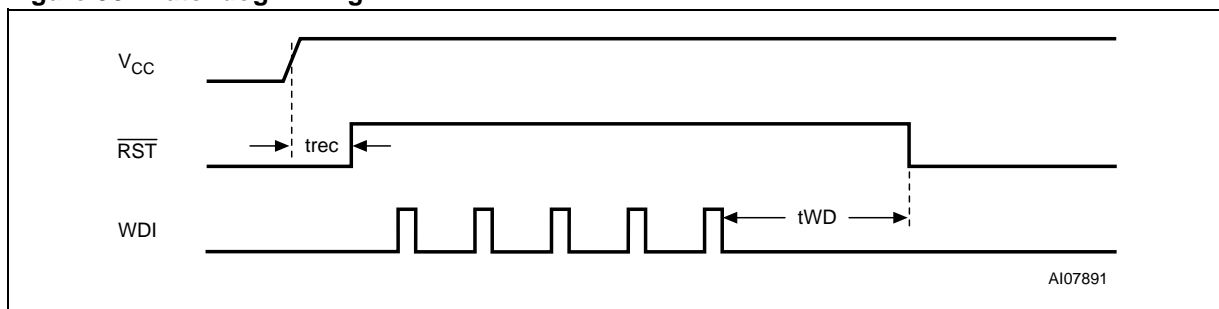


Table 7. DC and AC Characteristics

Sym	Alter-native	Description	Test Condition <sup>(1)</sup>	Min	Typ	Max	Unit
V <sub>CC</sub> , V <sub>BAT</sub> <sup>(2)</sup>		Operating Voltage	T <sub>A</sub> = -40 to +85°C	1.1 <sup>(3)</sup>		5.5	V
I <sub>CC</sub>		V <sub>CC</sub> Supply Current	Excluding I <sub>OUT</sub> (V <sub>CC</sub> < 5.5V)		40	60	μA
			Excluding I <sub>OUT</sub> (V <sub>CC</sub> < 3.6V)		35	50	μA
		V <sub>CC</sub> Supply Current in Battery Back-up Mode	Excluding I <sub>OUT</sub> (V <sub>BAT</sub> = 2.3V, V <sub>CC</sub> = 2.0V, MR = V <sub>CC</sub> )		25	35	μA
I <sub>BAT</sub> <sup>(4)</sup>		V <sub>BAT</sub> Supply Current in Battery Back-up Mode	Excluding I <sub>OUT</sub> (V <sub>BAT</sub> = 3.6V)		0.4	1.0	μA
V <sub>OUT1</sub>		V <sub>OUT</sub> Voltage (Active)	I <sub>OUT1</sub> = 5mA <sup>(5)</sup>	V <sub>CC</sub> - 0.03	V <sub>CC</sub> - 0.015		V
			I <sub>OUT1</sub> = 75mA	V <sub>CC</sub> - 0.3	V <sub>CC</sub> - 0.15		V
			I <sub>OUT1</sub> = 250μA, V <sub>CC</sub> > 2.5V <sup>(5)</sup>	V <sub>CC</sub> - 0.0015	V <sub>CC</sub> - 0.0006		V
V <sub>OUT2</sub>		V <sub>OUT</sub> Voltage (Battery Back-up)	I <sub>OUT2</sub> = 250μA, V <sub>BAT</sub> = 2.3V	V <sub>BAT</sub> - 0.1	V <sub>BAT</sub> - 0.034		V
			I <sub>OUT2</sub> = 1mA, V <sub>BAT</sub> = 2.3V		V <sub>BAT</sub> - 0.14		V
V <sub>CC</sub> to V <sub>OUT</sub> On-resistance					3	4	Ω
V <sub>BAT</sub> to V <sub>OUT</sub> On-resistance					100		Ω

Sym	Alter-native	Description	Test Condition <sup>(1)</sup>	Min	Typ	Max	Unit	
I <sub>LI</sub>		Input Leakage Current ( $\overline{MR}$ )	STM704/806 only; $\overline{MR} = 0V, V_{CC} = 3V$	20	75	350	$\mu A$	
		Input Leakage Current (PFI)	$0V = V_{IN} = V_{CC}$	-25	2	+25	nA	
		Input Leakage Current (WDI)	$0V = V_{IN} = V_{CC}$	-1		+1	$\mu A$	
I <sub>LO</sub>		Output Leakage Current	STM804/805/795; $0V = V_{IN} = V_{CC}$ <sup>(6)</sup>	-1		+1	$\mu A$	
V <sub>IH</sub>		Input High Voltage ( $\overline{MR}$ , WDI)	$V_{RST} (max) < V_{CC} < 5.5V$	0.7V <sub>CC</sub>			V	
V <sub>IL</sub>		Input Low Voltage ( $\overline{MR}$ , WDI)	$V_{RST} (max) < V_{CC} < 5.5V$			0.3V <sub>CC</sub>	V	
V <sub>OL</sub>		Output Low Voltage ( $\overline{PFO}$ , $\overline{RST}$ , RST, $\overline{V_{CCSW}}$ )	$V_{CC} = V_{RST} (max)$ , $I_{SINK} = 3.2mA$			0.3	V	
		Output Low Voltage ( $\overline{ECON}$ )	$V_{CC} = V_{RST} (max)$ , $I_{OUT} = 1.6mA, \overline{E} = 0V$			0.2V <sub>CC</sub>	V	
V <sub>OL</sub>		Output Low Voltage ( $\overline{RST}$ )	$I_{OL} = 40\mu A$ , $V_{CC} = 1.0V, V_{BAT} = V_{CC}$ , $T_A = 0^\circ C \text{ to } 85^\circ C$			0.3	V	
			$I_{OL} = 200\mu A$ , $V_{CC} = 1.2V, V_{BAT} = V_{CC}$			0.3	V	
V <sub>OH</sub>		Output High Voltage ( $\overline{RST}$ , RST) <sup>(7)</sup>	$I_{SOURCE} = 1mA$ , $V_{CC} = V_{RST} (max)$	2.4			V	
		Output High Voltage ( $\overline{ECON}$ )	$V_{CC} = V_{RST} (max)$ , $I_{OUT} = 1.6mA, \overline{E} = V_{CC}$	0.8V <sub>CC</sub>			V	
		Output High Voltage ( $\overline{PFO}$ )	$I_{SOURCE} = 75\mu A$ , $V_{CC} = V_{RST} (max)$	0.8V <sub>CC</sub>			V	
V <sub>OHB</sub>		V <sub>OH</sub> Battery Back-up ( $\overline{V_{CCSW}}$ , RST)	$I_{SOURCE} = 100\mu A$ , $V_{CC} = 0V, V_{BAT} = 2.8V$	0.8V <sub>BAT</sub>			V	
		V <sub>OH</sub> Battery Back-up ( $\overline{ECON}$ )	$I_{SOURCE} = 75\mu A$ , $V_{CC} = 0V, V_{BAT} = 2.8V$	0.8V <sub>BAT</sub>			V	
<b>Power-fail Comparator (NOT available on STM795)</b>								
V <sub>PFI</sub>		PFI Input Threshold	PFI Falling ( $V_{CC} < 3.6V$ )	STM802/ 804/806	1.212	1.237	1.262	V
				STM690/ 704/805	1.187	1.237	1.287	V
		PFI Hysteresis	PFI Rising ( $V_{CC} < 3.6V$ )		10	20	mV	
t <sub>PFD</sub>		PFI to $\overline{PFO}$ Propagation Delay			2		$\mu s$	
I <sub>SC</sub>		$\overline{PFO}$ Output Short to GND Current	$V_{CC} = 3.6V, \overline{PFO} = 0V$	0.1	0.75	2.0	mA	
<b>Battery Switchover</b>								
V <sub>SO</sub>		Battery Back-up Switchover Voltage <sup>(8,9)</sup>	Power-down	$V_{BAT} > V_{SW}$		V <sub>SW</sub>		V
				$V_{BAT} < V_{SW}$		V <sub>BAT</sub>		V
			Power-up	$V_{BAT} > V_{SW}$		V <sub>SW</sub>		V
				$V_{BAT} < V_{SW}$		V <sub>BAT</sub>		V
			V <sub>sw</sub>			2.4		V
		Hysteresis			40		mV	

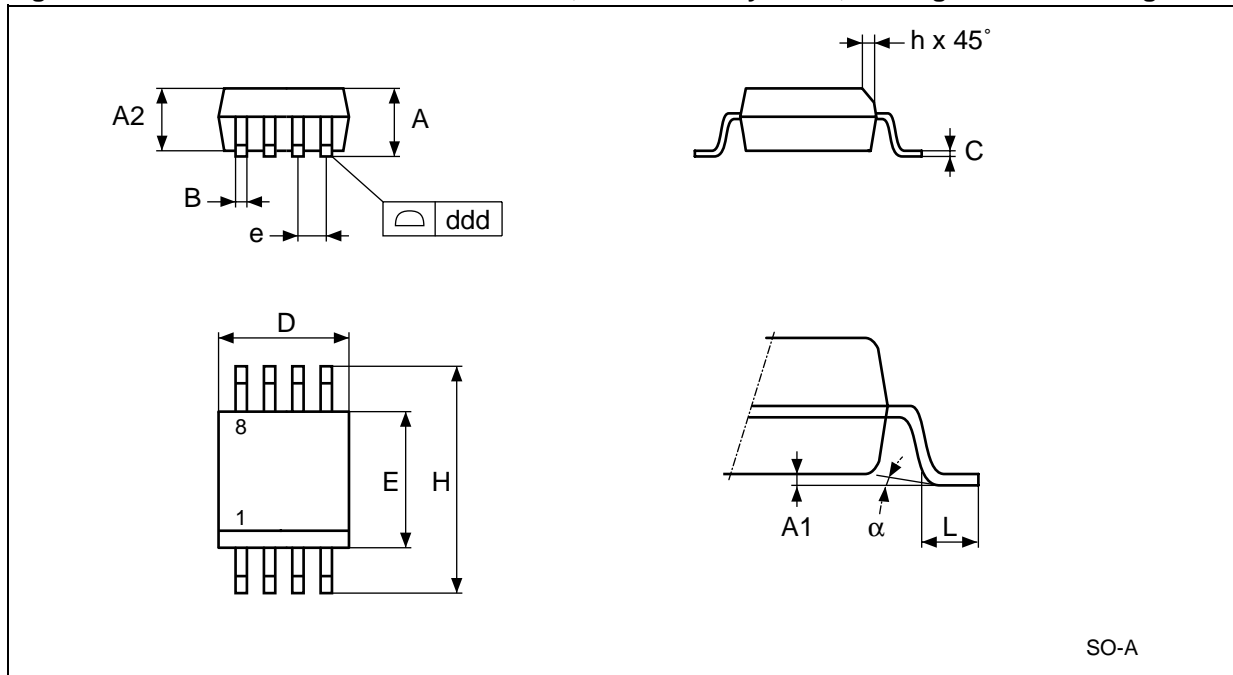
## STM690/704/795/802/804/805/806

Sym	Alternative	Description	Test Condition <sup>(1)</sup>	Min	Typ	Max	Unit	
<b>Reset Thresholds</b>								
V <sub>RST</sub> <sup>(10)</sup>		Reset Threshold	STM690T/ 704T/795T/ 805T	V <sub>CC</sub> Falling	3.00	3.075	3.15	V
				V <sub>CC</sub> Rising	3.00	3.085	3.17	V
			STM802T/ 804T/806T	V <sub>CC</sub> Falling	3.00	3.075	3.12	V
				V <sub>CC</sub> Rising	3.00	3.085	3.14	V
			STM690S/ 704S/795S/ 805S	V <sub>CC</sub> Falling	2.85	2.925	3.00	V
				V <sub>CC</sub> Rising	2.85	2.935	3.02	V
			STM802S/ 804S/806S	V <sub>CC</sub> Falling	2.88	2.925	3.00	V
				V <sub>CC</sub> Rising	2.88	2.935	3.02	V
			STM690R/ 704R/795R/ 805R	V <sub>CC</sub> Falling	2.55	2.625	2.70	V
				V <sub>CC</sub> Rising	2.55	2.635	2.72	V
			STM802R/ 804R/806R	V <sub>CC</sub> Falling	2.59	2.625	2.70	V
				V <sub>CC</sub> Rising	2.59	2.635	2.72	V
t <sub>rec</sub>		$\overline{\text{RST}}$ Pulse Width	V <sub>CC</sub> < 3.6V	140	200	280	ms	
<b>Push-button Reset Input (STM704/806)</b>								
t <sub>MLMH</sub>	t <sub>MR</sub>	$\overline{\text{MR}}$ Pulse Width		100	20		ns	
t <sub>MLRL</sub>	t <sub>MRD</sub>	$\overline{\text{MR}}$ to $\overline{\text{RST}}$ Output Delay			60	500	ns	
<b>Watchdog Timer (NOT available on STM704/795/806)</b>								
t <sub>WD</sub>		Watchdog Timeout Period	V <sub>RST</sub> (max) < V <sub>CC</sub> < 3.6V	1.12	1.60	2.24	s	
		WDI Pulse Width	V <sub>RST</sub> (max) < V <sub>CC</sub> < 3.6V	100	20		ns	
<b>Chip-Enable Gating (STM795 only)</b>								
		$\overline{\text{E}}$ -to- $\overline{\text{ECON}}$ Resistance	V <sub>CC</sub> = V <sub>RST</sub> (max)		46		Ω	
		$\overline{\text{E}}$ -to- $\overline{\text{ECON}}$ Propagation Delay	V <sub>CC</sub> = V <sub>RST</sub> (max)		2	7	ns	
		Reset-to- $\overline{\text{ECON}}$ High Delay			10		μs	
I <sub>SC</sub>		$\overline{\text{ECON}}$ Short Circuit Current	V <sub>CC</sub> = 3.6V, Disable Mode, $\overline{\text{ECON}}$ = 0V	0.1	0.75	2.0	mA	

- Note: 1. Valid for Ambient Operating Temperature: T<sub>A</sub> = -40 to 85°C; V<sub>CC</sub> = V<sub>RST</sub> (max) to 5.5V; and V<sub>BAT</sub> = 2.8V (except where noted).  
2. V<sub>CC</sub> supply current, logic input leakage, Watchdog functionality, Push-button Reset functionality, PFI functionality, state of RST and RST tested at V<sub>BAT</sub> = 3.6V, and V<sub>CC</sub> = 5.5V. The state of RST or RST and PFO is tested at V<sub>CC</sub> = V<sub>CC</sub> (min). Either V<sub>CC</sub> or V<sub>BAT</sub> can go to 0V if the other is greater than 2.0V.  
3. V<sub>CC</sub> (min) = 1.0V for T<sub>A</sub> = 0°C to +85°C.  
4. Tested at V<sub>BAT</sub> = 3.6V, V<sub>CC</sub> = 3.5V and 0V.  
5. Guaranteed by design.  
6. The leakage current measured on the RST pin (STM804/805) or  $\overline{\text{RST}}$  pin (STM795) is tested with the reset output not asserted (output high impedance).  
7. Not valid for STM795/804/805 (open drain).  
8. When V<sub>BAT</sub> > V<sub>CC</sub> > V<sub>SW</sub>, V<sub>OUT</sub> remains connected to V<sub>CC</sub> until V<sub>CC</sub> drops below V<sub>SW</sub>.  
9. When V<sub>SW</sub> > V<sub>CC</sub> > V<sub>BAT</sub>, V<sub>OUT</sub> remains connected to V<sub>CC</sub> until V<sub>CC</sub> drops below the battery voltage (V<sub>BAT</sub>) - 75mV.  
10. The reset threshold tolerance is wider for V<sub>CC</sub> rising than for V<sub>CC</sub> falling due to the 10mV (typ) hysteresis, which prevents internal oscillation.

**PACKAGE MECHANICAL**

**Figure 39. SO8 – 8-lead Plastic Small Outline, 150 mils body width, Package Mech. Drawing**

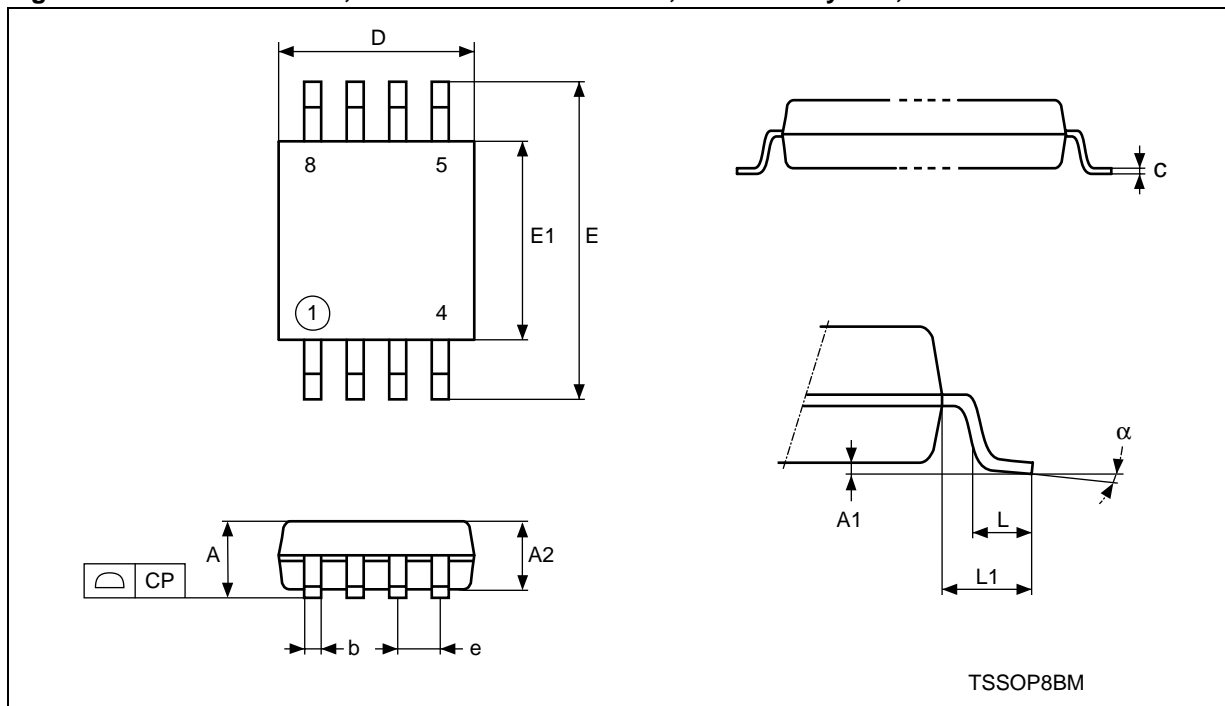


Note: Drawing is not to scale.

**Table 8. SO8 – 8-lead Plastic Small Outline, 150 mils body width, Package Mechanical Data**

Symb	mm			inches		
	Typ	Min	Max	Typ	Min	Max
A	–	1.35	1.75	–	0.053	0.069
A1	–	0.10	0.25	–	0.004	0.010
B	–	0.33	0.51	–	0.013	0.020
C	–	0.19	0.25	–	0.007	0.010
D	–	4.80	5.00	–	0.189	0.197
ddd	–	–	0.10	–	–	0.004
E	–	3.80	4.00	–	0.150	0.157
e	1.27	–	–	0.050	–	–
H	–	5.80	6.20	–	0.228	0.244
h	–	0.25	0.50	–	0.010	0.020
L	–	0.40	0.90	–	0.016	0.035
α	–	0°	8°	–	0°	8°
N	8			8		

Figure 40. TSSOP8 – 8-lead, Thin Shrink Small Outline, 3x3mm body size, Outline



Note: Drawing is not to scale.

Table 9. TSSOP8 – 8-lead, Thin Shrink Small Outline, 3x3mm body size, Mechanical Data

Symb	mm			inches		
	Typ	Min	Max	Typ	Min	Max
A	–	–	1.10	–	–	0.043
A1	–	0.05	0.15	–	0.002	0.006
A2	0.85	0.75	0.95	0.034	0.030	0.037
b	–	0.25	0.40	–	0.010	0.016
c	–	0.13	0.23	–	0.005	0.009
CP	–	–	0.10	–	–	0.004
D	3.00	2.90	3.10	0.118	0.114	0.122
e	0.65	–	–	0.026	–	–
E	4.90	4.65	5.15	0.193	0.183	0.203
E1	3.00	2.90	3.10	0.118	0.114	0.122
L	0.55	0.40	0.70	0.022	0.016	0.030
L1	0.95	–	–	0.037	–	–
α	–	0°	6°	–	0°	6°
N	8			8		

**PART NUMBERING**

**Table 10. Ordering Information Scheme**

Example:	STM690	T	M	6	E
<b>Device Type</b>					
STM690/704/795/802/804/805/806					
<b>Reset Threshold Voltage</b>					
T = STM690/704/795/805 = $V_{RST} = 3.00V$ to $3.15V$ STM802/804/806 = $V_{RST} = 3.00V$ to $3.12V$					
S = STM690/704/795/805 = $V_{RST} = 2.85V$ to $3.00V$ STM802/804/806 = $V_{RST} = 2.88V$ to $3.00V$					
R = STM690/704/795/805 = $V_{RST} = 2.55V$ to $2.70V$ STM802/804/806 = $V_{RST} = 2.59V$ to $2.70V$					
<b>Package</b>					
M = SO8 DS <sup>(1)</sup> = TSSOP8					
<b>Temperature Range</b>					
6 = $-40$ to $85^{\circ}C$					
<b>Shipping Method</b>					
E = Tubes F = Tape & Reel					

Note: 1. Contact local ST sales office for availability.

For other options, or for more information on any aspect of this device, please contact the ST Sales Office nearest you.

**Table 11. Marking Description**

Part Number	Reset Threshold	Package	Topside Marking
STM690T	3.075	SO8	690T
		TSSOP8	
STM690S	2.925	SO8	690S
		TSSOP8	
STM690R	2.625	SO8	690R
		TSSOP8	
STM704T	3.075	SO8	704T
		TSSOP8	
STM704S	2.925	SO8	704S
		TSSOP8	
STM704R	2.625	SO8	704R
		TSSOP8	
STM795T	3.075	SO8	795T
		TSSOP8	
STM795S	2.925	SO8	795S
		TSSOP8	
STM795R	2.625	SO8	795R
		TSSOP8	
STM802T	3.075	SO8	802T
		TSSOP8	
STM802S	2.925	SO8	802S
		TSSOP8	
STM802R	2.625	SO8	802R
		TSSOP8	
STM804T	3.075	SO8	804T
		TSSOP8	
STM804S	2.925	SO8	804S
		TSSOP8	
STM804R	2.625	SO8	804R
		TSSOP8	
STM805T	3.075	SO8	805T
		TSSOP8	
STM805S	2.925	SO8	805S
		TSSOP8	
STM805R	2.625	SO8	805R
		TSSOP8	
STM806T	3.075	SO8	806T
		TSSOP8	
STM806S	2.925	SO8	806S
		TSSOP8	
STM806R	2.625	SO8	806R
		TSSOP8	

## REVISION HISTORY

**Table 12. Document Revision History**

Date	Version	Revision Details
October 31, 2003	1.0	First Issue
22-Dec-03	2.0	Reformatted; update characteristics (Figure 1, 3, 4, 11, 13, 14, 37; Table 1, 3, 4, 7, 9, 11)
16-Jan-04	2.1	Add Typical Operating Characteristics (Figure 17, 18, 20, 21, 22, 23, 24, 25, 26, 29, 30, 31, 32, 33, 34)
07-Apr-04	2.2	Update characteristics (Figure 13, 29, 30, Table 1, 3, 7)
25-May-04	3.0	Update characteristics (Table 3, 7)
02-Jul-04	4.0	Update package availability, pin description; promote document (Figure 1, 14; Table 3, 10)
29-Sep-04	5.0	Clarify root part numbers, pin descriptions, update characteristics (Figure 2, 3, 4, 5, 6, 7, 8, 9, 10, 11, 13, 14, 35; Table 1, 3, 6, 7, 10)
25-Feb-05	6.0	Update Characteristics (Figure 11, 16, 17, 18, 19, 20, 21, 22, 23, 24, 25, 26, 27, 28, 29, 30, 31, 32, 33, 34, 35; Table 7)

Information furnished is believed to be accurate and reliable. However, STMicroelectronics assumes no responsibility for the consequences of use of such information nor for any infringement of patents or other rights of third parties which may result from its use. No license is granted by implication or otherwise under any patent or patent rights of STMicroelectronics. Specifications mentioned in this publication are subject to change without notice. This publication supersedes and replaces all information previously supplied. STMicroelectronics products are not authorized for use as critical components in life support devices or systems without express written approval of STMicroelectronics.

The ST logo is a registered trademark of STMicroelectronics.

All other names are the property of their respective owners

© 2005 STMicroelectronics - All rights reserved

STMicroelectronics group of companies  
Australia - Belgium - Brazil - Canada - China - Czech Republic - Finland - France - Germany - Hong Kong - India - Israel - Italy - Japan -  
Malaysia - Malta - Morocco - Singapore - Spain - Sweden - Switzerland - United Kingdom - United States of America  
[www.st.com](http://www.st.com)