

2.5V MICROPOWER SHUNT VOLTAGE REFERENCE

- 2.50V TYP. OUTPUT VOLTAGE
- ULTRA LOW CURRENT CONSUMPTION:
40µA TYP.
- HIGH PRECISION @ 25°C
±2% (Standard version)
±1% (A grade)
- HIGH STABILITY WHEN USED WITH
CAPACITIVE LOAD
- INDUSTRIAL TEMPERATURE RANGE:
-40 to +85°C
- 100ppm/°C MAXIMUM TEMPERATURE
COEFFICIENT

DESCRIPTION

The TS822 is a low power shunt voltage reference providing a stable 2.5V output voltage over the industrial temperature range (-40 to +85°C). Available in SOT23-3 surface mount package, it can be designed in applications where space saving is a critical issue.

The low operating current is a key advantage for power restricted designs. In addition, the TS822 is very stable and can be used in a broad range of application conditions.

APPLICATION

- Computers
- Instrumentation
- Battery chargers
- Switch Mode Power Supply
- Battery operated equipments

ORDER CODE

Precision	TO92	SOT23-3	SOT23 Marking
2%	TS822IZ	TS822IL	L223
1%	TS822AIZ	TS822AIL	L222
Single temperature range: -40 to +85°C			

Z = TO92 Plastic package - also available in Bulk (Z), Tape & Reel (ZT) and Ammo Pack (AP)

LT = Tiny Package (SOT23-3) - only available in Tape & Reel (LT)

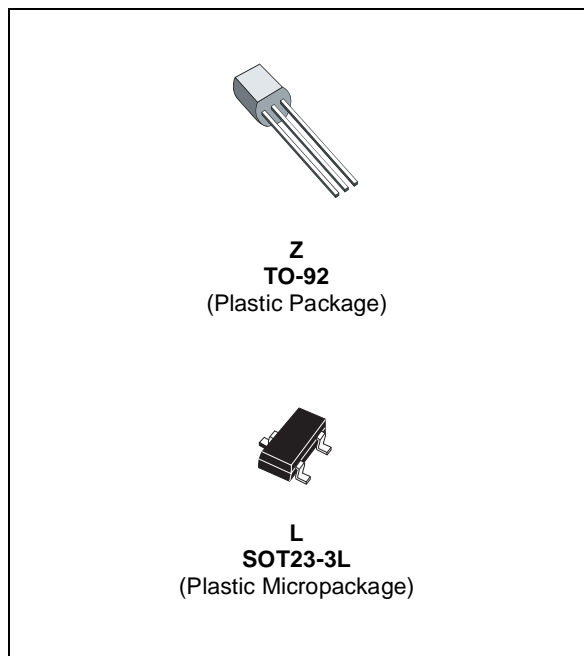

PIN CONNECTIONS (top view)

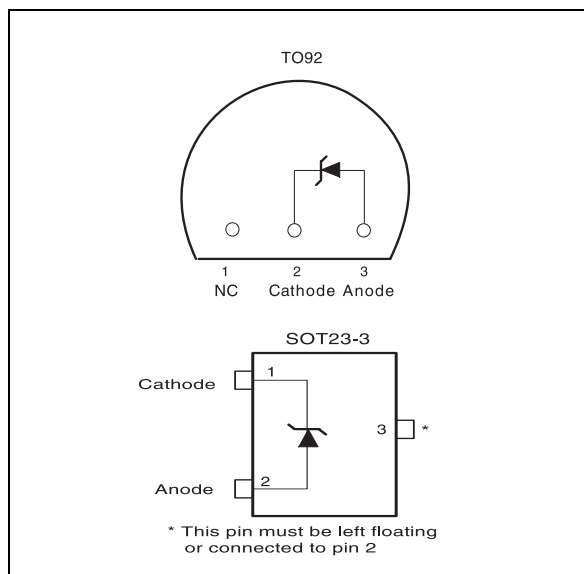

ABSOLUTE MAXIMUM RATINGS

Symbol	Parameter	Value	Unit
I_k	Reverse Breakdown Current	20	mA
I_f	Forward Current	10	mA
P_d	Power Dissipation ¹⁾ SOT23-3 TO-92	360 625	mW
T_{std}	Storage Temperature	-65 to +150	°C
ESD	Human Body Model (HBM)	2	kV
	Machine Model (MM)	200	V
T_{lead}	Lead Temperature (soldering, 10 seconds)	260	°C

1. P_d has been calculated with $T_{amb} = 25^\circ\text{C}$ and $R_{thja} = 200^\circ\text{C/W}$ for the TO92 package
 $R_{thja} = 340^\circ\text{C/W}$ for the STO23-3L package

OPERATING CONDITIONS

Symbol	Parameter	Value	Unit
I_{kmin}	Minimum Operating Current	50	μA
I_{kmax}	Maximum Operating Current	15	mA
T_{oper}	Operating Free Air Temperature Range	-40 to +85	°C

ELECTRICAL CHARACTERISTICS**TS822 (2% Precision)**

Tamb = 25°C (unless otherwise specified)

Symbol	Parameter	Test Condition	Min.	Typ.	Max.	Unit
Vk	Reverse Breakdown Voltage	$I_k = 100\mu\text{A}$	2.45	2.5	2.55	V
	Reverse Breakdown Voltage Tolerance	$I_k = 100\mu\text{A}$ $-40^\circ\text{C} < T < +85^\circ\text{C}$	-50 -66		50 66	mV
Ikmin	Minimum Operating Current	$T = 25^\circ\text{C}$		40	50	μA
		$-40^\circ\text{C} < T < +85^\circ\text{C}$			60	
$\Delta V_{\text{ref}}/\Delta T$	Average Temperature Coefficient	$I_k = 100\mu\text{A}$		30	100	ppm/°C
$\Delta V_k/\Delta I_k$	Reverse Breakdown Voltage Change with Operating Current Range	$I_{k\text{min}} < I_k < 1\text{mA}$ $-40^\circ\text{C} < T < +85^\circ\text{C}$		0.4	1 1.2	mV
		$1\text{mA} < I_k < 15\text{mA}$ $-40^\circ\text{C} < T < +85^\circ\text{C}$		2.5	8 10	
Rka	Reverse Static Impedance	$I_k = I_{k\text{min}} \text{ to } 1\text{mA}$ $-40^\circ\text{C} < T < +85^\circ\text{C}$		0.4	1 1.2	Ω
		$I_k = 1 \text{ to } 15\text{mA}$ $-40^\circ\text{C} < T < +85^\circ\text{C}$		0.2	0.6 0.7	
Kvh	Long Term Stability	$I_k = 100\mu\text{A}$, $t = 1000\text{hrs}$		120		ppm
En	Wide Band Noise	$I_k = 100\mu\text{A}$ $10\text{Hz} < f < 10\text{kHz}$		35		μV_{rms}

Note : Limits are 100% production tested at 25°C. Limits over temperature are guaranteed through correlation and by design.

ELECTRICAL CHARACTERISTICS**TS822A (1% Precision)**

Tamb = 25°C (unless otherwise specified)

Symbol	Parameter	Test Condition	Min.	Typ.	Max.	Unit
Vk	Reverse Breakdown Voltage	$I_k = 100\mu\text{A}$	2.475	2.5	2.525	V
	Reverse Breakdown Voltage Tolerance	$I_k = 100\mu\text{A}$ $-40^\circ\text{C} < T < +85^\circ\text{C}$	-25 -41		25 41	mV
Ikmin	Minimum Operating Current	$T = 25^\circ\text{C}$		40	50	μA
		$-40^\circ\text{C} < T < +85^\circ\text{C}$			60	
$\Delta V_{\text{ref}}/\Delta T$	Average Temperature Coefficient	$I_k = 100\mu\text{A}$		30	100	ppm/°C
$\Delta V_k/\Delta I_k$	Reverse Breakdown Voltage Change with Operating Current Range	$I_{k\text{min}} < I_k < 1\text{mA}$ $-40^\circ\text{C} < T < +85^\circ\text{C}$		0.4	1 1.2	mV
		$1\text{mA} < I_k < 15\text{mA}$ $-40^\circ\text{C} < T < +85^\circ\text{C}$		2.5	8 10	
Rka	Reverse Static Impedance	$I_k = I_{k\text{min}} \text{ to } 1\text{mA}$ $-40^\circ\text{C} < T < +85^\circ\text{C}$		0.4	1 1.2	Ω
		$I_k = 1\text{mA} \text{ to } 15\text{mA}$ $-40^\circ\text{C} < T < +85^\circ\text{C}$		0.2	0.6 0.7	
Kvh	Long Term Stability	$I_k = 100\mu\text{A}$, $t = 1000\text{hrs}$		120		ppm
En	Wide Band Noise	$I_k = 100\mu\text{A}$ $10\text{Hz} < f < 10\text{kHz}$		35		μV_{rms}

Note : Limits are 100% production tested at 25°C. Limits over temperature are guaranteed through correlation and by design.

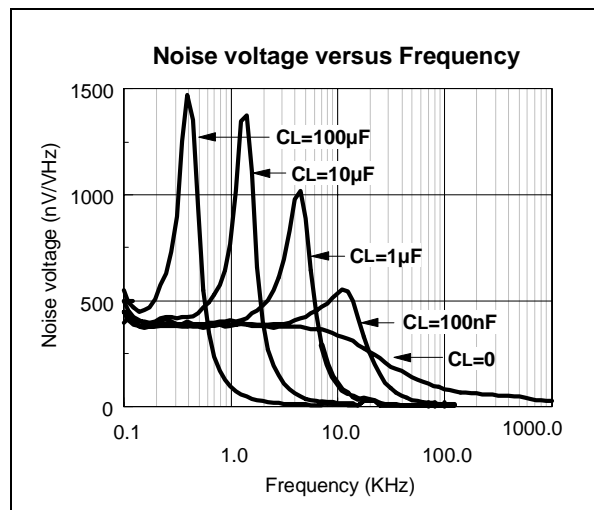
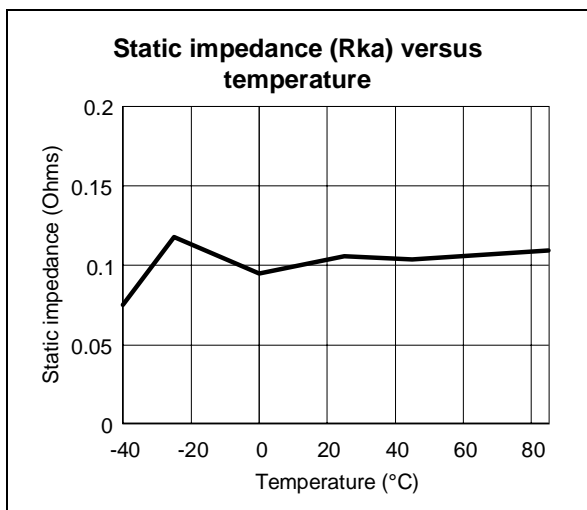
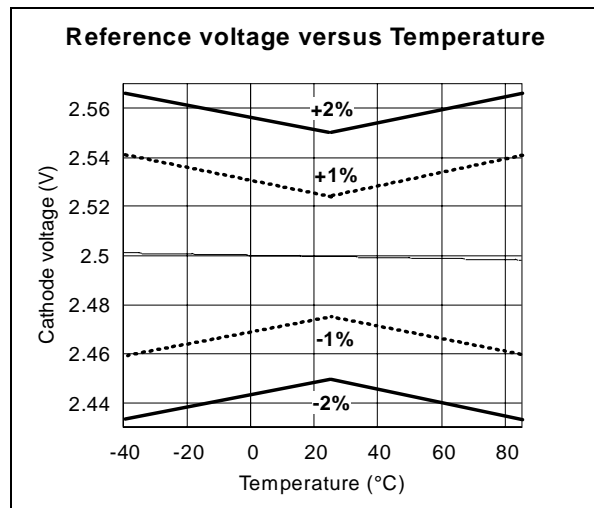
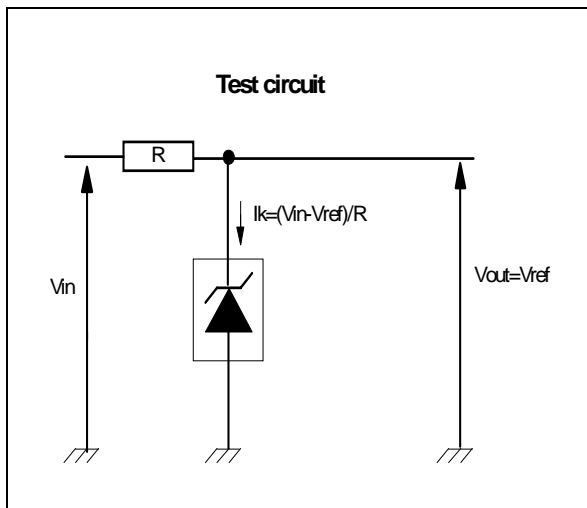
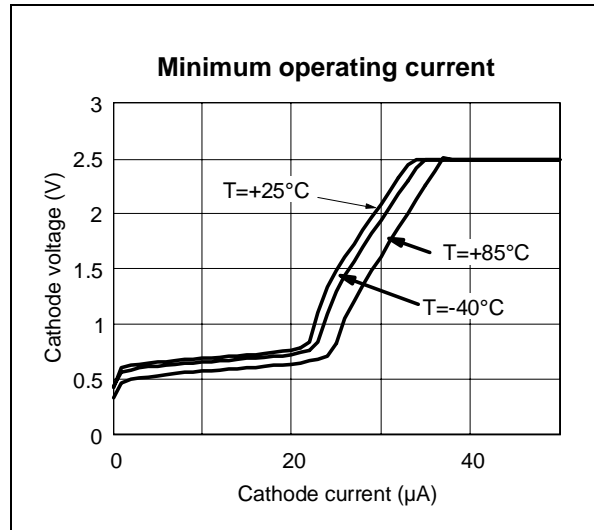
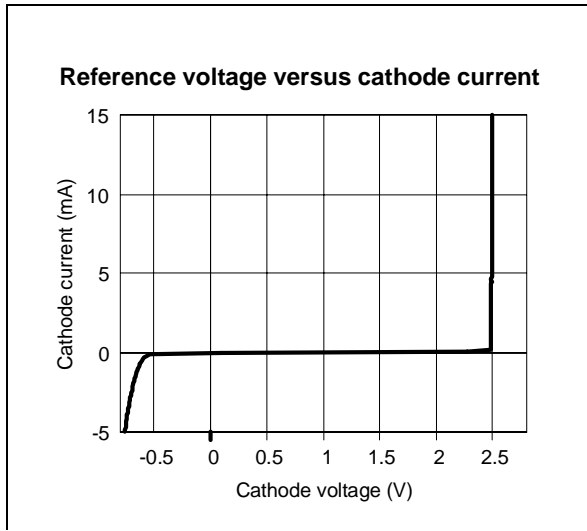

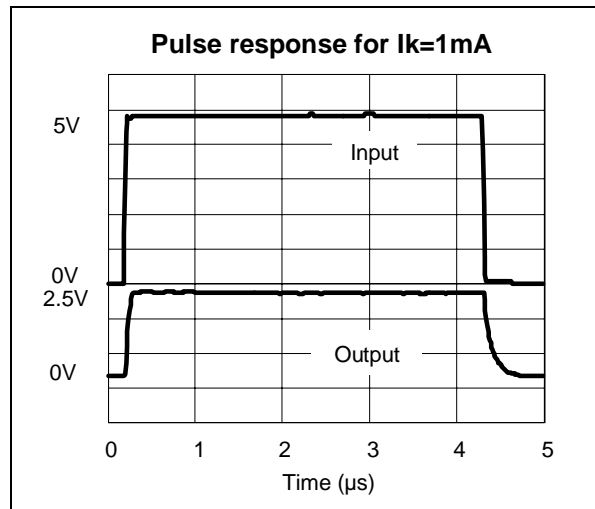
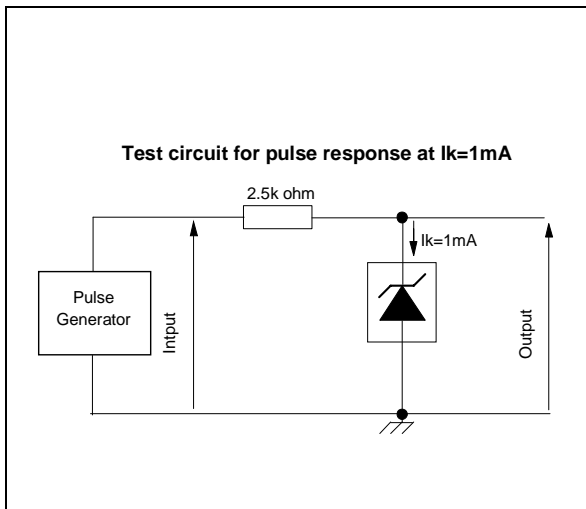
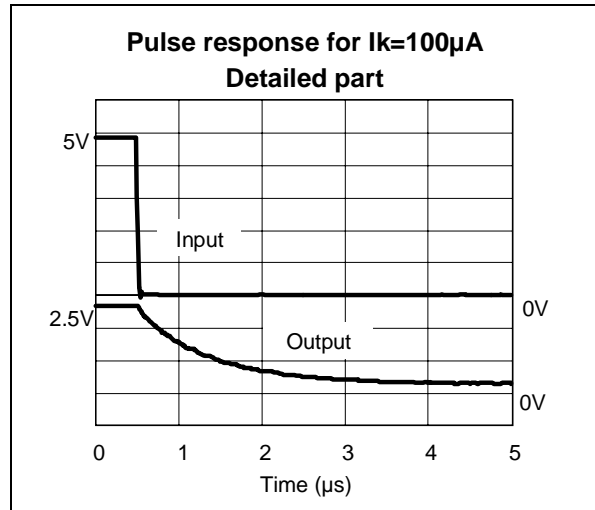
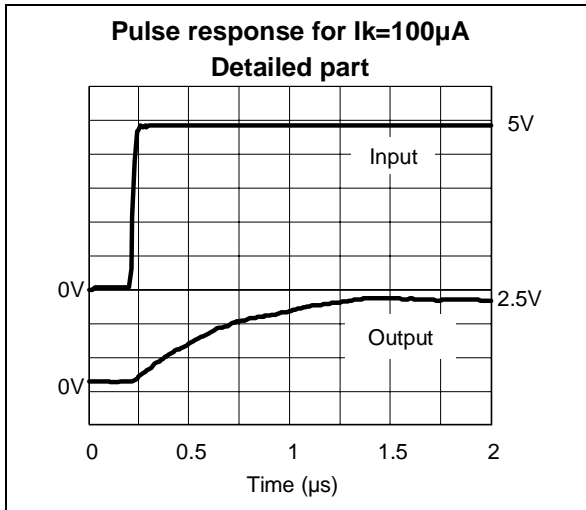
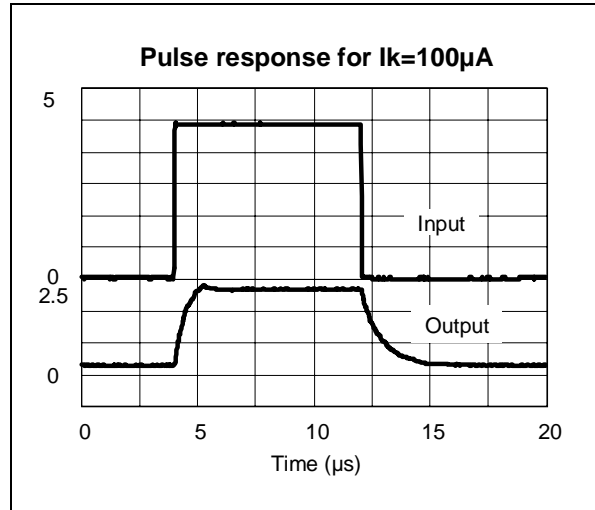
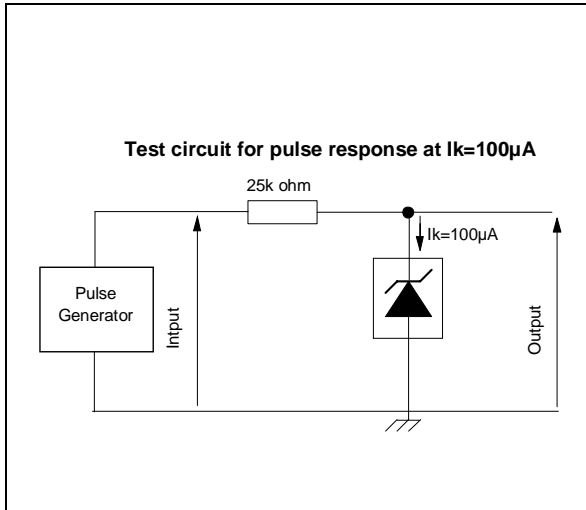

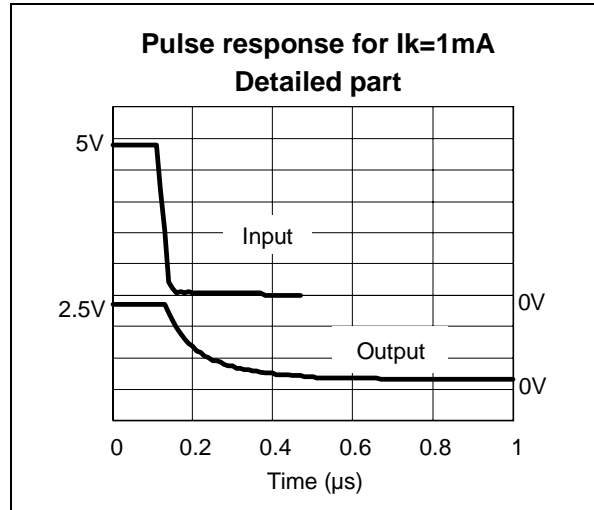
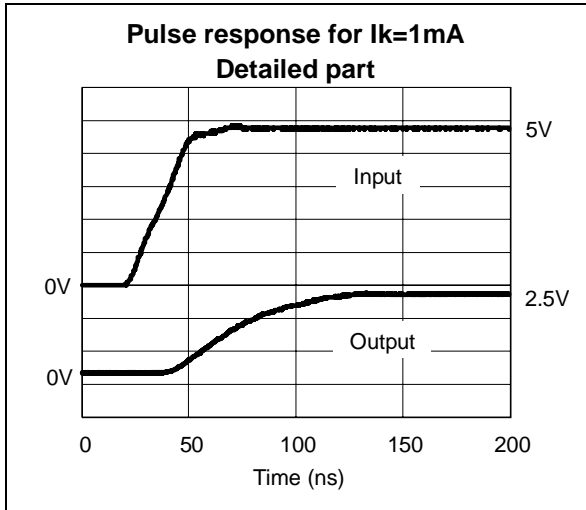

PACKAGE MECHANICAL DATA
3 PINS - PLASTIC PACKAGE TO92 (TAPE & REEL)

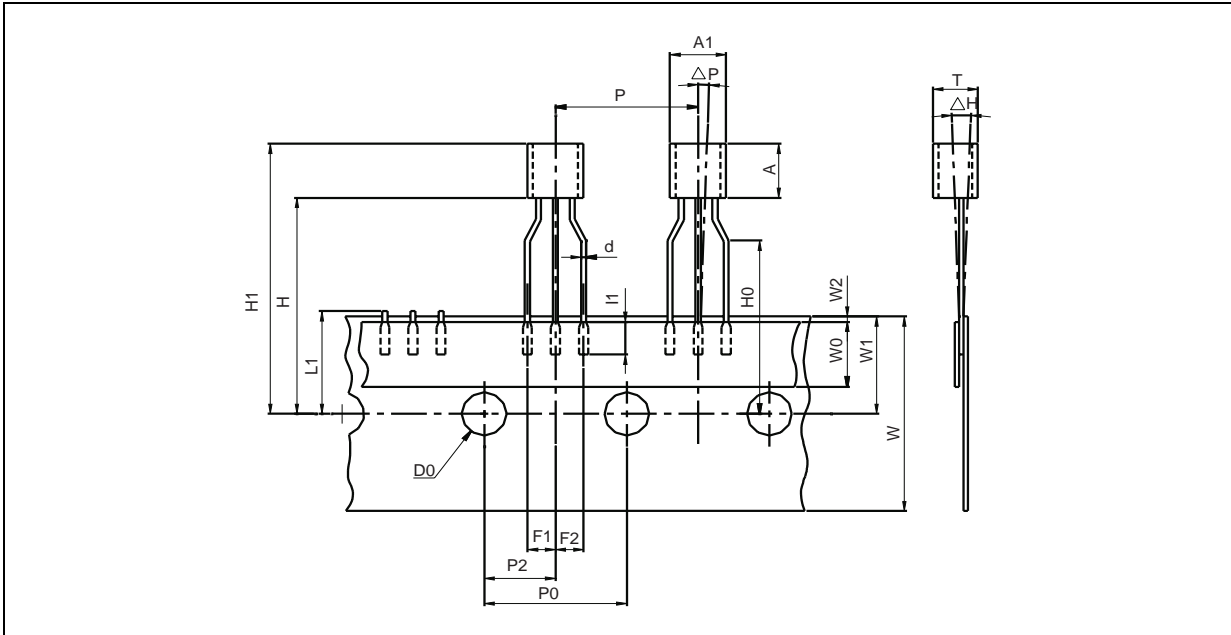

Dim.	Millimeters			Inches		
	Min	Typ.	Max.	Min.	Typ.	Max.
AL			5.0			0.197
A			5.0			0.197
T			4.0			0.157
d		0.45			0.018	
l1	2.5			0.098		
P	11.7	12.7	13.7	0.461	0.500	0.539
PO	12.4	12.7	13	0.488	0.500	0.512
P2	5.95	6.35	6.75	0.234	0.250	0.266
F1/F2	2.4	2.5	2.8	0.094	0.098	0.110
Δh	-1	0	1	-0.039	0	0.039
ΔP	-1	0	1	-0.039	0	0.039
W	17.5	18.0	19.0	0.689	0.709	0.748
W0	5.7	6	6.3	0.224	0.236	0.248
W1	8.5	9	9.75	0.335	0.354	0.384
W2			0.5			0.020
H			20			0.787
H0	15.5	16	16.5	0.610	0.630	0.650
H1			25			0.984
DO	3.8	4.0	4.2	0.150	0.157	0.165
L1			11			0.433

PACKAGE MECHANICAL DATA
3 PINS - PLASTIC PACKAGE TO92 (TAPE AMMO PACK)

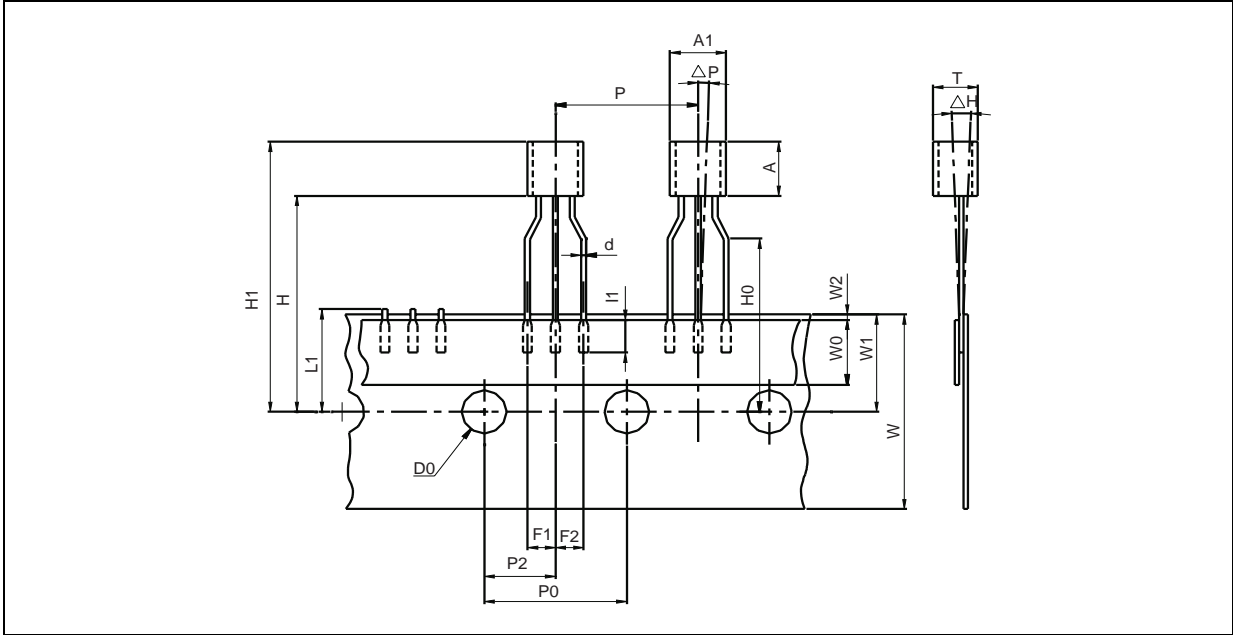

Dim.	Millimeters			Inches		
	Min	Typ.	Max.	Min.	Typ.	Max.
AL			5.0			0.197
A			5.0			0.197
T			4.0			0.157
d		0.45			0.018	
l1	2.5			0.098		
P	11.7	12.7	13.7	0.461	0.500	0.539
PO	12.4	12.7	13	0.488	0.500	0.512
P2	5.95	6.35	6.75	0.234	0.250	0.266
F1/F2	2.4	2.5	2.8	0.094	0.098	0.110
Δh	-1	0	1	-0.039	0	0.039
ΔP	-1	0	1	-0.039	0	0.039
W	17.5	18.0	19.0	0.689	0.709	0.748
W0	5.7	6	6.3	0.224	0.236	0.248
W1	8.5	9	9.75	0.335	0.354	0.384
W2			0.5			0.020
H			20			0.787
H0	15.5	16	16.5	0.610	0.630	0.650
H1			25			0.984
DO	3.8	4.0	4.2	0.150	0.157	0.165
L1			11			0.433

PACKAGE MECHANICAL DATA
3 PINS - PLASTIC PACKAGE TO92 (BULK)

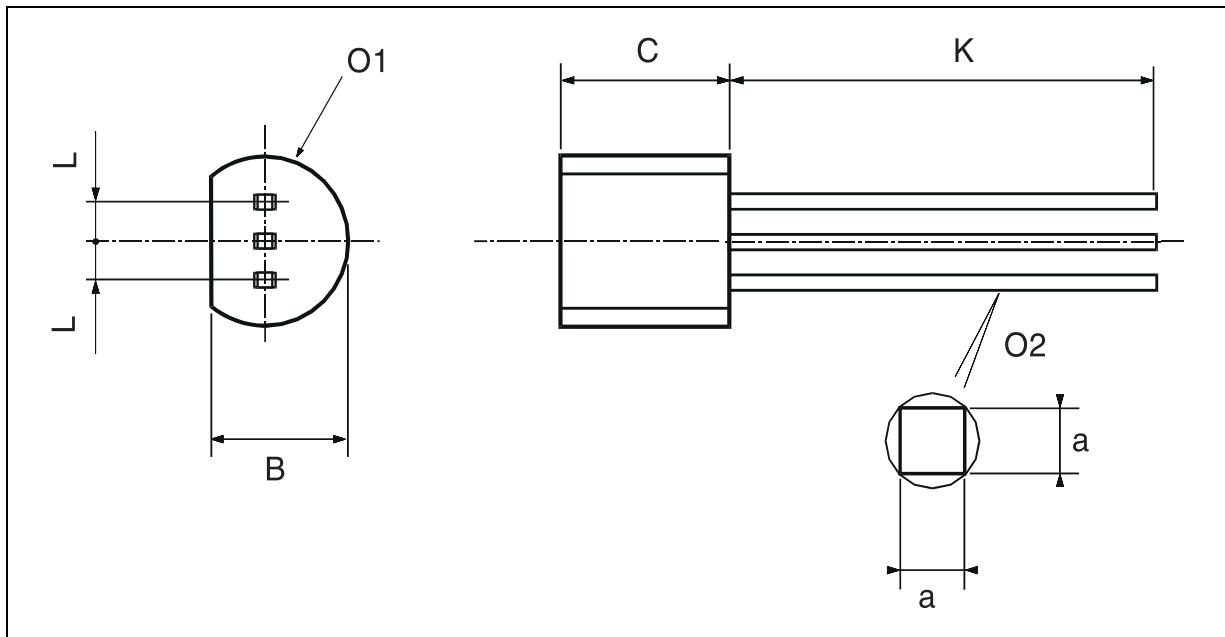

Dim.	Millimeters			Inches		
	Min	Typ.	Max.	Min.	Typ.	Max.
L		1.27			0.05	
B	3.2	3.7	4.2	0.126	0.1457	0.1654
O1	4.45	5.00	5.2	0.1752	0.1969	0.2047
C	4.58	5.03	5.33	0.1803	0.198	0.2098
K	12.7			0.5		
O2	0.407	0.5	0.508	0.016	0.0197	0.02
a	0.35			0.0138		

PACKAGE MECHANICAL DATA
3 PINS - TINY PACKAGE (SOT-23)

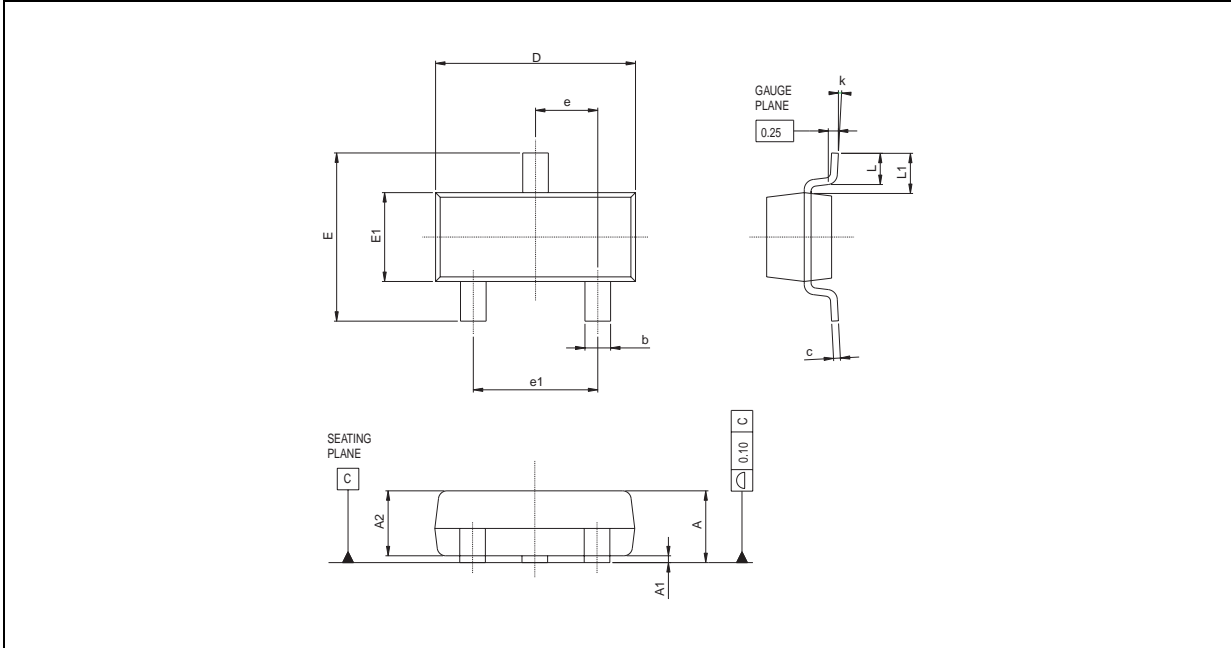

Dimensions	Millimeters			Inches		
	Min.	Typ.	Max.	Min.	Typ.	Max.
A	0.890		1.120	0.035		0.044
A1	0.010		0.100	0.0004		0.004
A2	0.880	0.950	1.020		0.037	0.040
b	0.300		0.500	0.012		0.020
c	0.080		0.200	0.003		0.008
D	2.800	2.900	3.040	0.110	0.114	0.120
E	2.100		2.640	0.083		0.104
E1	1.200	1.300	1.400	0.047	0.051	0.055
e		0.950			0.037	
e1		1.900			0.075	
L	0.400	0.500	0.600	0.016	0.020	0.024
L1		0.540			0.021	
k	0°		8°			

Information furnished is believed to be accurate and reliable. However, STMicroelectronics assumes no responsibility for the consequences of use of such information nor for any infringement of patents or other rights of third parties which may result from its use. No license is granted by implication or otherwise under any patent or patent rights of STMicroelectronics. Specifications mentioned in this publication are subject to change without notice. This publication supersedes and replaces all information previously supplied. STMicroelectronics products are not authorized for use as critical components in life support devices or systems without express written approval of STMicroelectronics.

© The ST logo is a registered trademark of STMicroelectronics

© 2002 STMicroelectronics - Printed in Italy - All Rights Reserved
STMicroelectronics GROUP OF COMPANIES

Australia - Brazil - Canada - China - Finland - France - Germany - Hong Kong - India - Israel - Italy - Japan - Malaysia
 Malta - Morocco - Singapore - Spain - Sweden - Switzerland - United Kingdom - United States

© <http://www.st.com> - United Kingdom