

LM27222 High-Speed 4.5A Synchronous MOSFET Driver

Check for Samples: [LM27222](#)

FEATURES

- Adaptive Shoot-through Protection
- 10ns Dead Time
- 8ns Propagation Delay
- 30ns Minimum On-time
- 0.4Ω Pull-down and 0.9Ω Pull-up Drivers
- 4.5A Peak Driving Current
- MOSFET Tolerant Design
- 5μA Quiescent Current
- 30V Maximum Input Voltage in Buck Configuration
- 4V to 6.85V Operating Voltage
- SOIC-8 and WSON Packages

APPLICATIONS

- High Current Buck And Boost Voltage Converters
- Fast Transient DC/DC Power Supplies
- Single Ended Forward Output Rectification
- CPU And GPU Core Voltage Regulators

DESCRIPTION

The LM27222 is a dual N-channel MOSFET driver designed to drive MOSFETs in push-pull configurations as typically used in synchronous buck regulators. The LM27222 takes the PWM output from a controller and provides the proper timing and drive levels to the power stage MOSFETs. Adaptive shoot-through protection prevents damaging and efficiency reducing shoot-through currents, thus ensuring a robust design capable of being used with nearly any MOSFET. The adaptive shoot-through protection circuitry also reduces the dead time down to as low as 10ns, ensuring the highest operating efficiency. The peak sourcing and sinking current for each driver of the LM27222 is about 3A and 4.5Amps respectively with a V_{gs} of 5V. System performance is also enhanced by keeping propagation delays down to 8ns. Efficiency is once again improved at all load currents by supporting synchronous, non-synchronous, and diode emulation modes through the LEN pin. The minimum output pulse width realized at the output of the MOSFETs is as low as 30ns. This enables high operating frequencies at very high conversion ratios in buck regulator designs. To support low power states in notebook systems, the LM27222 draws only 5μA from the 5V rail when the IN and LEN inputs are low or floating.

Typical Application

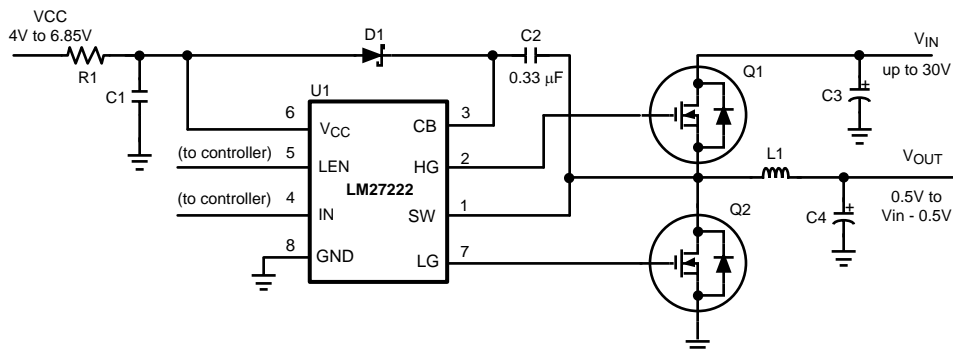

Please be aware that an important notice concerning availability, standard warranty, and use in critical applications of Texas Instruments semiconductor products and disclaimers thereto appears at the end of this data sheet.

All trademarks are the property of their respective owners.

Connection Diagram

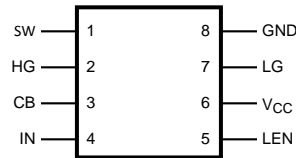
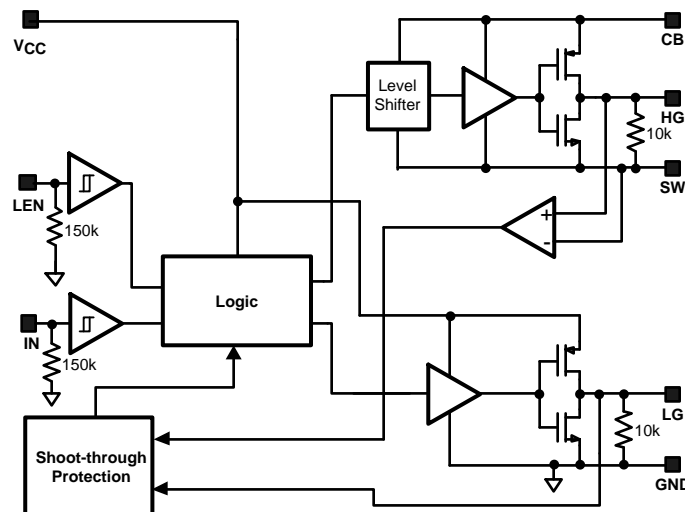

Figure 1. Top View
SOIC-8 (Package # D0008A) $\theta_{JA} = 172^{\circ}\text{C/W}$
or
WSO-8 (Package # NGT0008A) $\theta_{JA} = 39^{\circ}\text{C/W}$

PIN DESCRIPTIONS

Pin #	Pin Name	Pin Function
1	SW	High-side driver return. Should be connected to the common node of high and low-side MOSFETs.
2	HG	High-side gate drive output. Should be connected to the high-side MOSFET gate. Pulled down internally to SW with a 10K resistor to prevent spurious turn on of the high-side MOSFET when the driver is off.
3	CB	Bootstrap. Accepts a bootstrap voltage for powering the high-side driver.
4	IN	Accepts a PWM signal from a controller. Active High. Pulled down internally to GND with a 150K resistor to prevent spurious turn on of the high-side MOSFET when the controller is inactive.
5	LEN	Low-side gate enable. Active High. Pulled down internally to GND with a 150K resistor to prevent spurious turn-on of the low-side MOSFET when the controller is inactive.
6	V _{CC}	Connect to +5V supply.
7	LG	Low-side gate drive output. Should be connected to low-side MOSFET gate. Pulled down internally to GND with a 10K resistor to prevent spurious turn on of the low-side MOSFET when the driver is off.
8	GND	Ground.

Block Diagram



These devices have limited built-in ESD protection. The leads should be shorted together or the device placed in conductive foam during storage or handling to prevent electrostatic damage to the MOS gates.

Absolute Maximum Ratings ⁽¹⁾

V _{CC} to GND	-0.3V to 7V
CB to GND	-0.3V to 36V
CB to SW	-0.3V to 7V
SW to GND ⁽²⁾	-2V to 36V
LEN, IN, LG to GND	-0.3V to V _{CC} + 0.3V ≤ 7V
HG to GND	-0.3V to 36V
Junction Temperature	+150°C
Power Dissipation ⁽³⁾	720mW
Storage Temperature	-65° to 150°C
ESD Susceptibility Human Body Model	2kV

- (1) **Absolute Maximum Ratings** are limits beyond which damage to the device may occur. **Operating ratings** are conditions under which the device operates correctly. Operating Ratings do not imply ensured performance limits.
- (2) The SW pin can have -2V to -0.5 volts applied for a maximum duty cycle of 10% with a maximum period of 1 second. There is no duty cycle or maximum period limitation for a SW pin voltage range of -0.5V to 30 Volts.
- (3) Maximum allowable power dissipation is a function of the maximum junction temperature, T_{JMAX}, the junction-to-ambient thermal resistance, θ_{JA}, and the ambient temperature, T_A. The maximum allowable power dissipation at any ambient temperature is calculated using: P_{MAX} = (T_{JMAX} - T_A) / θ_{JA}. The junction-to-ambient thermal resistance, θ_{JA}, for the LM27222M, it is 165°C/W. For a T_{JMAX} of 150°C and T_A of 25°C, the maximum allowable power dissipation is 0.76W. The θ_{JA} for the LM27222SD is 42°C/W. For a T_{JMAX} of 150°C and T_A of 25°C, the maximum allowable power dissipation is 3W.

Operating Ratings ⁽¹⁾

VCC	4V to 6.85V
Junction Temperature Range	-40° to 125°C
CB (max)	33V

- (1) **Absolute Maximum Ratings** are limits beyond which damage to the device may occur. **Operating ratings** are conditions under which the device operates correctly. Operating Ratings do not imply ensured performance limits.

Electrical Characteristics ⁽¹⁾

VCC = CB = 5V, SW = GND = 0V, unless otherwise specified. Typical and limits appearing in plain type apply for T_A = T_J = +25°C. Limits appearing in **boldface** type apply over the entire operating temperature range (-40°C ≤ T_J ≤ 125°C).

Symbol	Parameter	Conditions	Min	Typ	Max	Units
POWER SUPPLY						
I _{q_op}	Operating Quiescent Current	IN = 0V, LEN = 0V		5	15	μA
				30		
		IN = 0V, LEN = 5V	500	540	650	μA
					825	
HIGH-SIDE DRIVER						
	Peak Pull-up Current			3		A
R _{H-pu}	Pull-up Rds_on	I _{CB} = I _{HG} = 0.3A		0.9	2.5	Ω
	Peak Pull-down Current			4.5		A
R _{H-pd}	Pull-down Rds_on	I _{SW} = I _{HG} = 0.3A		0.4	1.5	Ω
t ₄	Rise Time	Timing Diagram, C _{LOAD} = 3.3nF		17		ns
t ₆	Fall Time	Timing Diagram, C _{LOAD} = 3.3nF		12		ns
t ₃	Pull-up Dead Time	Timing Diagram		9.5		ns
t ₅	Pull-down Delay	Timing Diagram		16.5		ns
t _{on_min}	Minimum Positive Output Pulse Width			30		ns
LOW-SIDE DRIVER						
	Peak Pull-up Current			3.2		A
R _{L-pu}	Pull-up Rds_on	I _{VCC} = I _{LG} = 0.3A		0.9	2.5	Ω
	Peak Pull-down Current			4.5		A
R _{L-pd}	Pull-down Rds_on	I _{GND} = I _{LG} = 0.3A		0.4	1.5	Ω
t ₈	Rise Time	Timing Diagram, C _{LOAD} = 3.3nF		17		ns
t ₂	Fall Time	Timing Diagram, C _{LOAD} = 3.3nF		14		ns
t ₇	Pull-up Dead Time	Timing Diagram		11.5		ns
t ₁	Pull-down Delay	Timing Diagram		7.7		ns
PULL-DOWN RESISTANCES						
	HG-SW Pull-down Resistance			10k		Ω
	LG-GND Pull-down Resistance			10k		Ω
	LEN-GND Pull-down Resistance			150K		Ω
	IN-GND Pull-down Resistance			150K		Ω
LEAKAGE CURRENTS						
I _{leak_IN}	IN pin Leakage Current	IN = 0V, Source Current		50		nA
		IN = 5V, Sink Current		33		μA
I _{leak_LEN}	LEN pin Leakage Current	LEN = 0V, Source Current		200		nA
		LEN = 5V, Sink Current		33		μA
LOGIC						
V _{IH_LEN}	LEN Low to High Threshold	Low to High Transition			65	% of V _{CC}
V _{IL_LEN}	LEN High to Low Threshold	High to Low Transition	30			% of V _{CC}
V _{IH_IN}	IN Low to High Threshold	Low to High Transition			65	% of V _{CC}
V _{IL_IN}	IN High to Low Threshold	High to Low Transition	30			% of V _{CC}
	Threshold Hysteresis			0.7		V

(1) Min and Max limits are 100% production tested at 25°C. Limits over the operating temperature range are ensured through correlation using Statistical Quality Control (SQC) methods. Limits are used to calculate Average Outgoing Quality Level (AOQL).

Timing Diagram

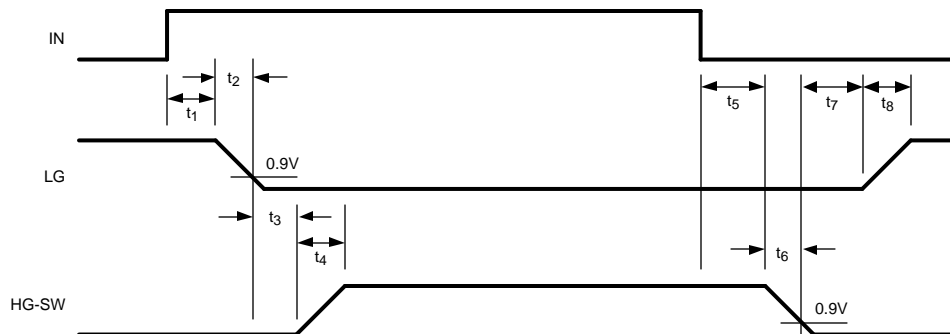

Typical Waveforms

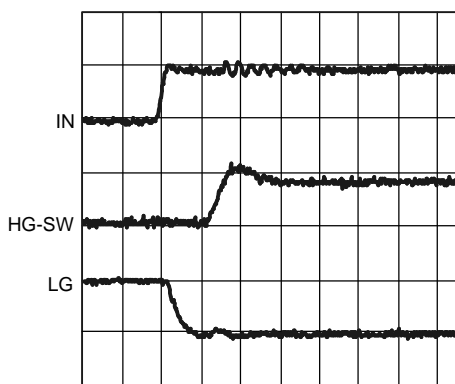

Figure 2. PWM Low-to-High Transition at IN Input

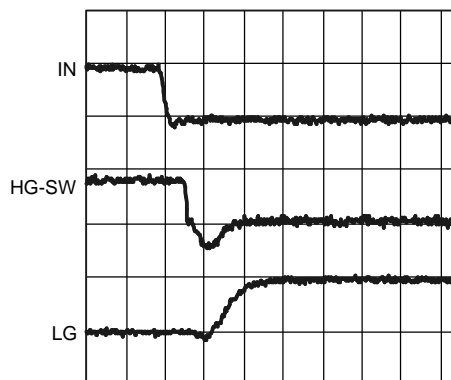

Figure 3. PWM High-to-Low Transition at IN Input

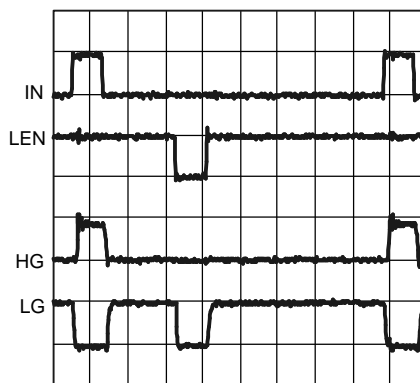

Figure 4. LEN Operation

The typical waveforms are from a circuit similar to [Typical Application](#) with:

Q1: 2 x Si7390DP

Q2: 2 x Si7356DP

L1: 0.4 μ H

V_{IN} : 12V

APPLICATION INFORMATION

GENERAL

The LM27222 is designed for high speed and high operating reliability. The driver can handle very narrow, down to zero, PWM pulses in a specified, deterministic way. Therefore, the HG and LG outputs are always in predictable states. No latches are used in the HG and LG control logic so the drivers cannot get "stuck" in the wrong state. The driver design allows for powering up with a pre-biasing voltage being present at the regulator output. To reduce conduction losses in DC-DC converters with low duty factors the LM27222 driver can be powered from a 6.5V \pm 5% power rail.

It is recommended to use the same power rail for both the controller and driver. If two different power rails are used, never allow the PWM pulse magnitude at the IN input or the control voltage at the LEN input to be above the driver V_{CC} voltage or unpredictable HG and LG outputs pulse widths may result.

MINIMUM PULSE WIDTH

As the input pulse width to the IN pin is decreased, the pulse width of the high-side gate drive (HG-SW) also decreases. However, for input pulse widths 60ns and smaller, the HG-SW remains constant at 30ns. Thus the minimum pulse width of the driver output is 30ns. Figure 5 shows an input pulse at the IN pin 20ns wide, and the output of the driver, as measured between the nodes HG and SW is a 30ns wide pulse. Figure 6 shows the variation of the SW node pulse width vs IN pulse width. At the IN pin, if a falling edge is followed by a rising edge within 5ns, the HG may ignore the rising edge and remain low until the IN pin toggles again. If a rising edge is followed by a falling edge within 5ns, the pulse may be completely ignored.

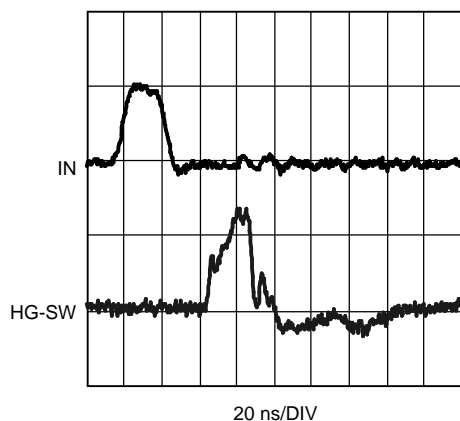

Figure 5. Min On Time

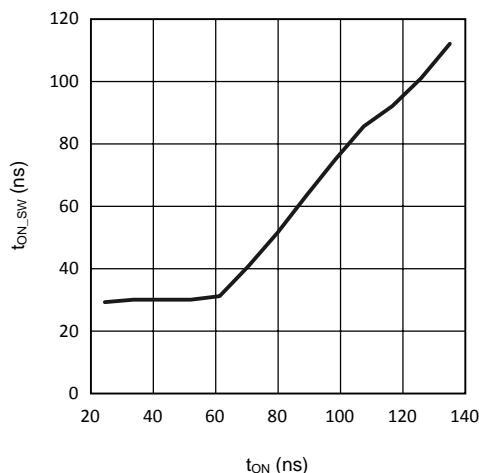

Figure 6.

ADAPTIVE SHOOT-THROUGH PROTECTION

The LM27222 prevents shoot-through power loss by ensuring that both the high- and low-side MOSFETs are not conducting at the same time. When the IN signal rises, LG is first pulled down. The adaptive shoot-through protection circuit waits for LG to reach 0.9V before turning on HG. Similarly, when IN goes low, HG is pulled down first, and the circuit turns LG on only after the voltage difference between the high-side gate and the switch node, i.e., HG-SW, has fallen to 0.9V.

It is possible in some applications that at power-up the driver's SW pin is above 3V in either buck or boost converter applications. For instance, in a buck configuration a pre-biasing voltage can be either a voltage from another power rail connected to the load, or a leakage voltage through the load, or it can be an output capacitor pre-charged above 3V while no significant load is present. In a boost application it can be an input voltage rail above 3V.

In the case of insufficient initial CB-SW voltage (less than 2V) such as when the output rail is pre-biased, the shoot-through protection circuit holds LG low for about 170ns, beginning from the instant when IN goes high. After the 170ns delay, the status of LG is dictated by LEN and IN. Once LG goes high and SW goes low, the bootstrap capacitor will be charged up (assuming SW is grounded for long enough time). As a result, CB-SW will be close to 5V and the LM27222 will now fully support synchronous operation.

The dead-time between the high- and low-side pulses is kept as small as possible to minimize conduction through the body diode of the low-side MOSFET(s).

POWER DISSIPATION

The power dissipated in the driver IC when switching synchronously can be calculated as follows:

$$P = \frac{f_{SW} \times V_{CC}}{2} \left\{ Q_{G-H} \left[\frac{R_{H-pu}}{R_{H-pu} + R_{G-H}} + \frac{R_{H-pd}}{R_{H-pd} + R_{G-H}} \right] + Q_{G-L} \left[\frac{R_{L-pu}}{R_{L-pu} + R_{G-L}} + \frac{R_{L-pd}}{R_{L-pd} + R_{G-L}} \right] \right\}$$

where

- where f_{SW} = switching frequency
- V_{CC} = voltage at the V_{CC} pin
- Q_{G-H} = total gate charge of the (parallel combination of the) high-side MOSFET(s)
- Q_{G-L} = total gate charge of the (parallel combination of the) low-side MOSFET(s)
- R_{G-H} = gate resistance of the (parallel combination of the) high-side MOSFET(s)
- R_{G-L} = gate resistance of the (parallel combination of the) low-side MOSFET(S)
- R_{H-pu} = pull-up R_{DS_ON} of the high-side driver
- R_{H-pd} = pull-down R_{DS_ON} of the high-side driver
- R_{L-pu} = pull-up R_{DS_ON} of the low-side driver
- R_{L-pd} = pull-down R_{DS_ON} of the low-side driver

(1)

PC BOARD LAYOUT GUIDELINES

1. Place the driver as close to the MOSFETs as possible.
2. HG, SW, LG, GND: Run short, thick traces between the driver and the MOSFETs. To minimize parasitics, the traces for HG and SW should run parallel and close to each other. The same is true for LG and GND.
3. Driver V_{CC} : Place the decoupling capacitor close to the V_{CC} and GND pins.
4. The high-current loop between the high-side and low-side MOSFETs and the input capacitors should be as small as possible.
5. There should be enough copper area near the MOSFETs and the inductor for heat dissipation. Vias may also be added to carry the heat to other layers.

TYPICAL APPLICATION CIRCUIT DESCRIPTION

The Application Example on the following page shows the LM27222 being used with the LM27212, a 2-phase hysteretic current mode controller. Although this circuit is capable of operating from 5V to 28V, the components are optimized for an input voltage range of 9V to 28V. The high-side FET is selected for low gate charge to reduce switching losses. For low duty cycles, the average current through the high-side FET is relatively small and thus we trade off higher conduction losses for lower switching losses. The low-side FET is selected solely on R_{DS_ON} to minimize conduction losses. If the input voltage range were 4V to 6V, the MOSFET selection should be changed. First, much lower voltage FETs can be used, and secondly, high-side FET R_{DS_ON} becomes a larger loss factor than the switching losses. Of course with a lower input voltage, the input capacitor voltage rating can be reduced and the inductor value can be reduced as well. For a 4V to 6V application, the inductor can be reduced to 200nH to 300nH. The switching frequency of the LM27212 is determined by the allowed ripple current in the inductor. This circuit is set for approximately 300kHz. At lower input voltages, higher frequencies are possible without suffering a significant efficiency loss. Although the LM27222 can support operating frequencies up to 2MHz in many applications, the LM27212 should be limited to about 1MHz. The control architecture of the LM27212 and the low propagation times of the LM27222 potentially gives this solution the fastest transient response in the industry.

Application Example

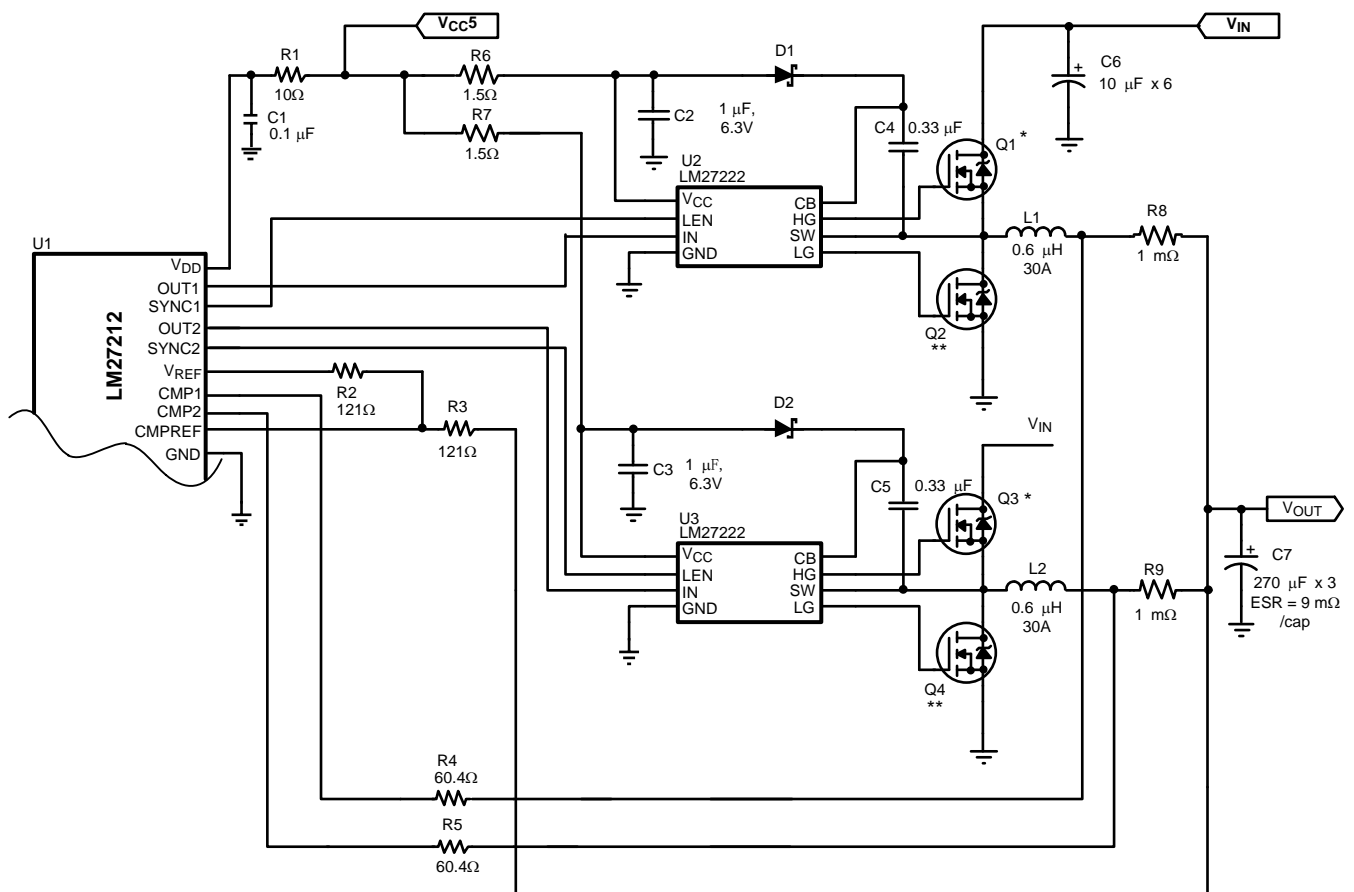

* Q1, Q3: 2 x Si7390DP

** Q2, Q4: 2 x Si7356DP

REVISION HISTORY

Changes from Revision A (March 2013) to Revision B	Page
<hr/> <ul style="list-style-type: none">• Changed layout of National Data Sheet to TI format <hr/>	<hr/> 8 <hr/>

PACKAGING INFORMATION

Orderable Device	Status (1)	Package Type	Package Drawing	Pins	Package Qty	Eco Plan (2)	Lead/Ball Finish	MSL Peak Temp (3)	Op Temp (°C)	Top-Side Markings (4)	Samples
LM27222M	ACTIVE	SOIC	D	8	95	TBD	Call TI	Call TI	-40 to 125	27222 M	Samples
LM27222M/NOPB	ACTIVE	SOIC	D	8	95	Green (RoHS & no Sb/Br)	CU SN	Level-1-260C-UNLIM	-40 to 125	27222 M	Samples
LM27222MX	ACTIVE	SOIC	D	8	2500	TBD	Call TI	Call TI	-40 to 125	27222 M	Samples
LM27222MX/NOPB	ACTIVE	SOIC	D	8	2500	Green (RoHS & no Sb/Br)	CU SN	Level-1-260C-UNLIM	-40 to 125	27222 M	Samples
LM27222SD	ACTIVE	WSON	NGT	8	1000	TBD	Call TI	Call TI	-40 to 125	L27222S	Samples
LM27222SD/NOPB	ACTIVE	WSON	NGT	8	1000	Green (RoHS & no Sb/Br)	SN	Level-1-260C-UNLIM	-40 to 125	L27222S	Samples

(1) The marketing status values are defined as follows:

ACTIVE: Product device recommended for new designs.

LIFEBUY: TI has announced that the device will be discontinued, and a lifetime-buy period is in effect.

NRND: Not recommended for new designs. Device is in production to support existing customers, but TI does not recommend using this part in a new design.

PREVIEW: Device has been announced but is not in production. Samples may or may not be available.

OBSOLETE: TI has discontinued the production of the device.

(2) Eco Plan - The planned eco-friendly classification: Pb-Free (RoHS), Pb-Free (RoHS Exempt), or Green (RoHS & no Sb/Br) - please check <http://www.ti.com/productcontent> for the latest availability information and additional product content details.

TBD: The Pb-Free/Green conversion plan has not been defined.

Pb-Free (RoHS): TI's terms "Lead-Free" or "Pb-Free" mean semiconductor products that are compatible with the current RoHS requirements for all 6 substances, including the requirement that lead not exceed 0.1% by weight in homogeneous materials. Where designed to be soldered at high temperatures, TI Pb-Free products are suitable for use in specified lead-free processes.

Pb-Free (RoHS Exempt): This component has a RoHS exemption for either 1) lead-based flip-chip solder bumps used between the die and package, or 2) lead-based die adhesive used between the die and leadframe. The component is otherwise considered Pb-Free (RoHS compatible) as defined above.

Green (RoHS & no Sb/Br): TI defines "Green" to mean Pb-Free (RoHS compatible), and free of Bromine (Br) and Antimony (Sb) based flame retardants (Br or Sb do not exceed 0.1% by weight in homogeneous material)

(3) MSL, Peak Temp. -- The Moisture Sensitivity Level rating according to the JEDEC industry standard classifications, and peak solder temperature.

(4) Multiple Top-Side Markings will be inside parentheses. Only one Top-Side Marking contained in parentheses and separated by a "~" will appear on a device. If a line is indented then it is a continuation of the previous line and the two combined represent the entire Top-Side Marking for that device.

Important Information and Disclaimer: The information provided on this page represents TI's knowledge and belief as of the date that it is provided. TI bases its knowledge and belief on information provided by third parties, and makes no representation or warranty as to the accuracy of such information. Efforts are underway to better integrate information from third parties. TI has taken and

continues to take reasonable steps to provide representative and accurate information but may not have conducted destructive testing or chemical analysis on incoming materials and chemicals. TI and TI suppliers consider certain information to be proprietary, and thus CAS numbers and other limited information may not be available for release.

In no event shall TI's liability arising out of such information exceed the total purchase price of the TI part(s) at issue in this document sold by TI to Customer on an annual basis.

TAPE AND REEL INFORMATION

QUADRANT ASSIGNMENTS FOR PIN 1 ORIENTATION IN TAPE

*All dimensions are nominal

Device	Package Type	Package Drawing	Pins	SPQ	Reel Diameter (mm)	Reel Width W1 (mm)	A0 (mm)	B0 (mm)	K0 (mm)	P1 (mm)	W (mm)	Pin1 Quadrant
LM27222MX	SOIC	D	8	2500	330.0	12.4	6.5	5.4	2.0	8.0	12.0	Q1
LM27222MX/NOPB	SOIC	D	8	2500	330.0	12.4	6.5	5.4	2.0	8.0	12.0	Q1
LM27222SD	WSO	NGT	8	1000	178.0	12.4	4.3	4.3	1.3	8.0	12.0	Q1
LM27222SD/NOPB	WSO	NGT	8	1000	178.0	12.4	4.3	4.3	1.3	8.0	12.0	Q1

TAPE AND REEL BOX DIMENSIONS



*All dimensions are nominal

Device	Package Type	Package Drawing	Pins	SPQ	Length (mm)	Width (mm)	Height (mm)
LM27222MX	SOIC	D	8	2500	367.0	367.0	35.0
LM27222MX/NOPB	SOIC	D	8	2500	367.0	367.0	35.0
LM27222SD	WSON	NGT	8	1000	210.0	185.0	35.0
LM27222SD/NOPB	WSON	NGT	8	1000	210.0	185.0	35.0

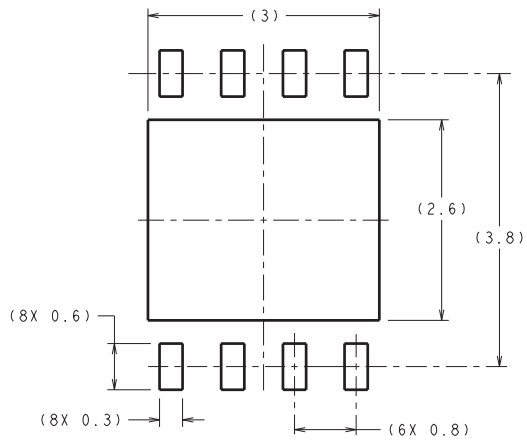
NGT0008A

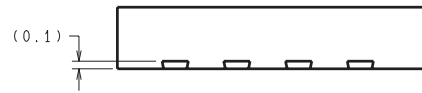

DIMENSIONS ARE IN MILLIMETERS
DIMENSIONS IN () FOR REFERENCE ONLY



RECOMMENDED LAND PATTERN

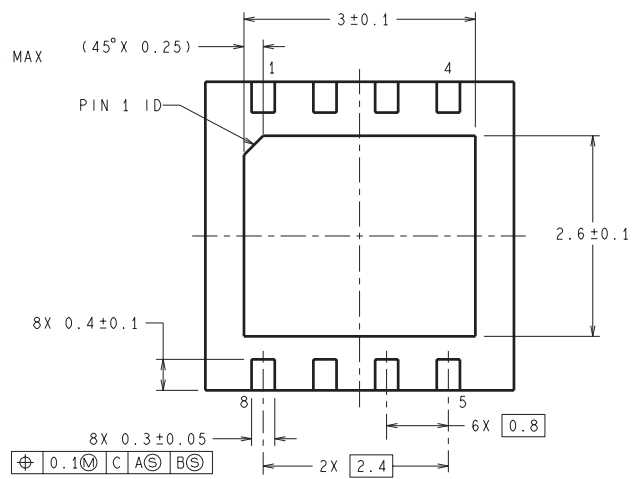
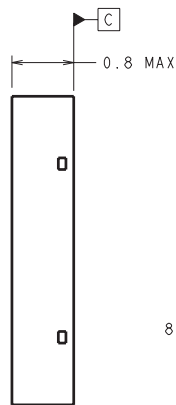
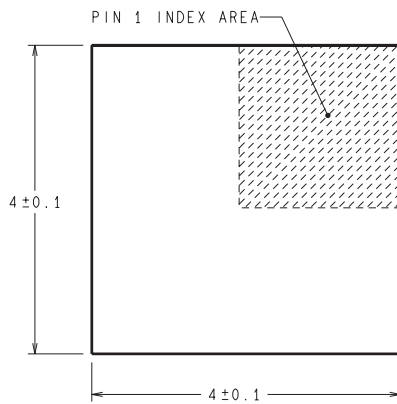

$\oplus 0.1 \text{ (M)}$ C | A $\text{\textcircled{S}}$ B $\text{\textcircled{S}}$

SDC08A (Rev A)

D (R-PDSO-G8)

PLASTIC SMALL OUTLINE

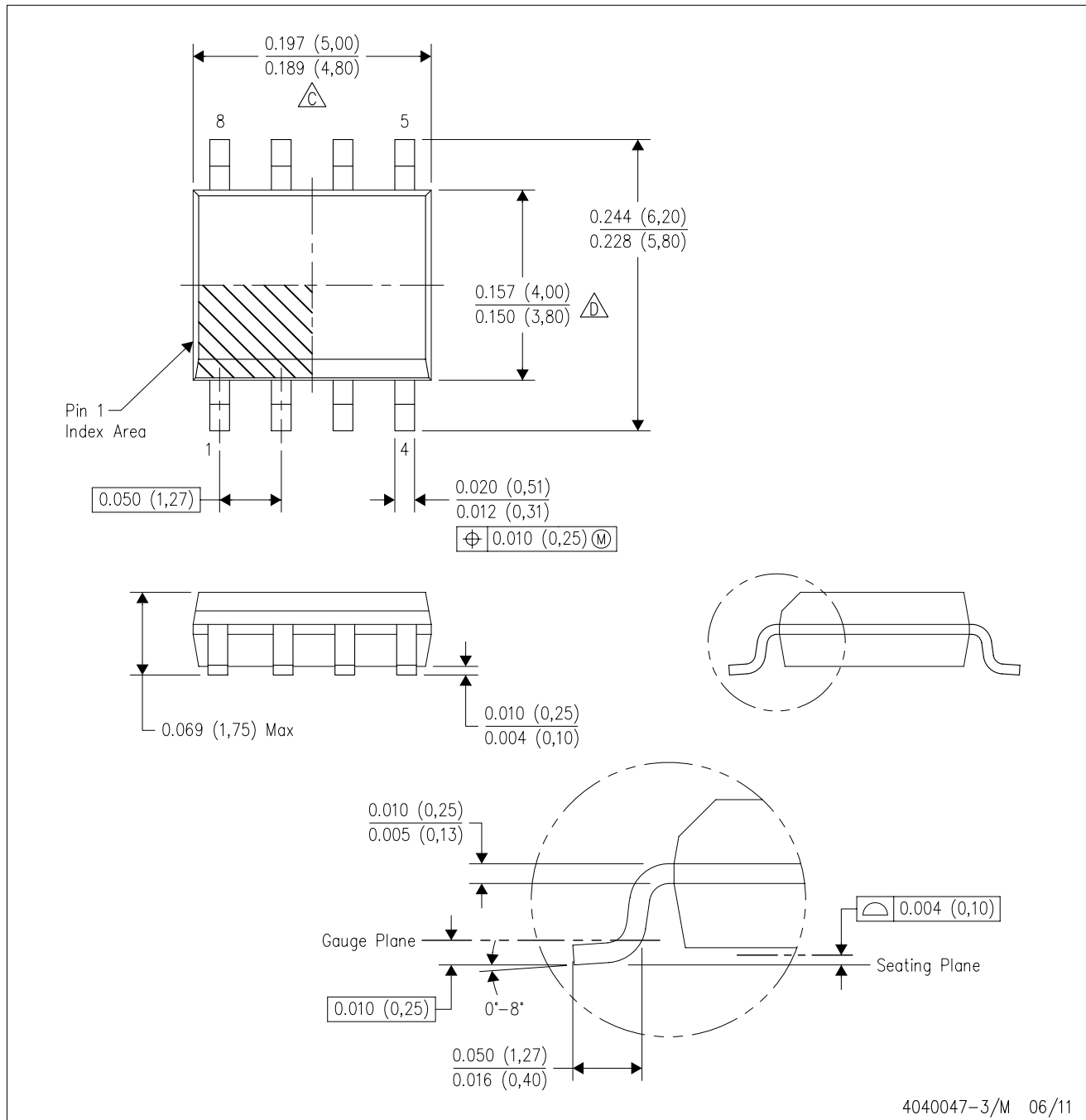

- NOTES:
- A. All linear dimensions are in inches (millimeters).
 - B. This drawing is subject to change without notice.
 - C. Body length does not include mold flash, protrusions, or gate burrs. Mold flash, protrusions, or gate burrs shall not exceed 0.006 (0,15) each side.
 - D. Body width does not include interlead flash. Interlead flash shall not exceed 0.017 (0,43) each side.
 - E. Reference JEDEC MS-012 variation AA.

IMPORTANT NOTICE

Texas Instruments Incorporated and its subsidiaries (TI) reserve the right to make corrections, enhancements, improvements and other changes to its semiconductor products and services per JESD46, latest issue, and to discontinue any product or service per JESD48, latest issue. Buyers should obtain the latest relevant information before placing orders and should verify that such information is current and complete. All semiconductor products (also referred to herein as "components") are sold subject to TI's terms and conditions of sale supplied at the time of order acknowledgment.

TI warrants performance of its components to the specifications applicable at the time of sale, in accordance with the warranty in TI's terms and conditions of sale of semiconductor products. Testing and other quality control techniques are used to the extent TI deems necessary to support this warranty. Except where mandated by applicable law, testing of all parameters of each component is not necessarily performed.

TI assumes no liability for applications assistance or the design of Buyers' products. Buyers are responsible for their products and applications using TI components. To minimize the risks associated with Buyers' products and applications, Buyers should provide adequate design and operating safeguards.

TI does not warrant or represent that any license, either express or implied, is granted under any patent right, copyright, mask work right, or other intellectual property right relating to any combination, machine, or process in which TI components or services are used. Information published by TI regarding third-party products or services does not constitute a license to use such products or services or a warranty or endorsement thereof. Use of such information may require a license from a third party under the patents or other intellectual property of the third party, or a license from TI under the patents or other intellectual property of TI.

Reproduction of significant portions of TI information in TI data books or data sheets is permissible only if reproduction is without alteration and is accompanied by all associated warranties, conditions, limitations, and notices. TI is not responsible or liable for such altered documentation. Information of third parties may be subject to additional restrictions.

Resale of TI components or services with statements different from or beyond the parameters stated by TI for that component or service voids all express and any implied warranties for the associated TI component or service and is an unfair and deceptive business practice. TI is not responsible or liable for any such statements.

Buyer acknowledges and agrees that it is solely responsible for compliance with all legal, regulatory and safety-related requirements concerning its products, and any use of TI components in its applications, notwithstanding any applications-related information or support that may be provided by TI. Buyer represents and agrees that it has all the necessary expertise to create and implement safeguards which anticipate dangerous consequences of failures, monitor failures and their consequences, lessen the likelihood of failures that might cause harm and take appropriate remedial actions. Buyer will fully indemnify TI and its representatives against any damages arising out of the use of any TI components in safety-critical applications.

In some cases, TI components may be promoted specifically to facilitate safety-related applications. With such components, TI's goal is to help enable customers to design and create their own end-product solutions that meet applicable functional safety standards and requirements. Nonetheless, such components are subject to these terms.

No TI components are authorized for use in FDA Class III (or similar life-critical medical equipment) unless authorized officers of the parties have executed a special agreement specifically governing such use.

Only those TI components which TI has specifically designated as military grade or "enhanced plastic" are designed and intended for use in military/aerospace applications or environments. Buyer acknowledges and agrees that any military or aerospace use of TI components which have **not** been so designated is solely at the Buyer's risk, and that Buyer is solely responsible for compliance with all legal and regulatory requirements in connection with such use.

TI has specifically designated certain components as meeting ISO/TS16949 requirements, mainly for automotive use. In any case of use of non-designated products, TI will not be responsible for any failure to meet ISO/TS16949.

Products

Audio	www.ti.com/audio
Amplifiers	amplifier.ti.com
Data Converters	dataconverter.ti.com
DLP® Products	www.dlp.com
DSP	dsp.ti.com
Clocks and Timers	www.ti.com/clocks
Interface	interface.ti.com
Logic	logic.ti.com
Power Mgmt	power.ti.com
Microcontrollers	microcontroller.ti.com
RFID	www.ti-rfid.com
OMAP Applications Processors	www.ti.com/omap
Wireless Connectivity	www.ti.com/wirelessconnectivity

Applications

Automotive and Transportation	www.ti.com/automotive
Communications and Telecom	www.ti.com/communications
Computers and Peripherals	www.ti.com/computers
Consumer Electronics	www.ti.com/consumer-apps
Energy and Lighting	www.ti.com/energy
Industrial	www.ti.com/industrial
Medical	www.ti.com/medical
Security	www.ti.com/security
Space, Avionics and Defense	www.ti.com/space-avionics-defense
Video and Imaging	www.ti.com/video

TI E2E Community

e2e.ti.com