

LM285-2.5, LM385-2.5, LM385B-2.5 MICROPOWER VOLTAGE REFERENCES

SLVS023G – JANUARY 1989 – REVISED NOVEMBER 2002

- Operating Current Range . . . 20 μ A to 20 mA
- 1.5% and 3% Initial Voltage Tolerance
- Reference Impedance
 - LM385 . . . 1 Ω Max at 25°C
 - All Devices . . . 1.5 Ω Max Over Full Temperature Range
- Very Low Power Consumption
- Applications:
 - Portable Meter References
 - Portable Test Instruments
 - Battery-Operated Systems
 - Current-Loop Instrumentation
 - Panel Meters
- Interchangeable With Industry Standard LM285-2.5 and LM385-2.5

LM285-2.5 . . . D PACKAGE
LM385-2.5, LM385B-2.5 . . . D OR PW PACKAGE
(TOP VIEW)

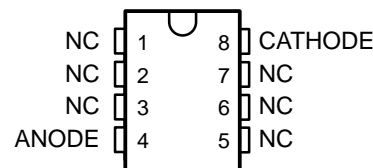

NC – No internal connection

LM285-2.5, LM385-2.5, LM385B-2.5 . . . LP PACKAGE
(TOP VIEW)

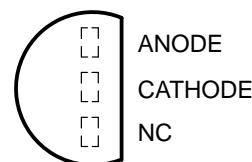

NC – No internal connection

description/ordering information

These micropower two-terminal band-gap voltage references operate over a 20- μ A to 20-mA current range and feature exceptionally low dynamic impedance and good temperature stability. On-chip trimming provides tight voltage tolerance. The band-gap reference for these devices has low noise and long-term stability.

ORDERING INFORMATION

TA	VZ TOLERANCE	PACKAGE†	ORDERABLE PART NUMBER	TOP-SIDE MARKING	
0°C to 70°C	3%	SOIC (D)	Tube of 75	LM385D-2-5	385-25
			Reel of 2000	LM385DR-2-5	
		TO-92 (LP)	Tube of 1000	LM385LP-2-5	385-25
			Reel of 2000	LM385LPR-2-5	
		TSSOP (PW)	Tube of 150	LM385PW-2-5	385-25
			Reel of 2000	LM385PWR-2-5	
	1.5%	SOIC (D)	Tube of 75	LM385BD-2-5	385B25
			Reel of 2000	LM385BDR-2-5	
		TO-92 (LP)	Tube of 1000	LM385BLP-2-5	385-25
			Reel of 2000	LM385BLPR-2-5	
		TSSOP (PW)	Tube of 150	LM385BPW-2-5	385B25
			Reel of 2000	LM385BPWR-2-5	
–40°C to 85°C	1.5%	SOIC (D)	Tube of 75	LM285D-2-5	285-25
			Reel of 2000	LM285DR-2-5	
		TO-92 (LP)	Tube of 1000	LM285LP-2-5	285-25
			Reel of 2000	LM285LPR-2-5	

†Package drawings, standard packing quantities, thermal data, symbolization, and PCB design guidelines are available at www.ti.com/sc/package.



Please be aware that an important notice concerning availability, standard warranty, and use in critical applications of Texas Instruments semiconductor products and disclaimers thereto appears at the end of this data sheet.

PRODUCTION DATA information is current as of publication date. Products conform to specifications per the terms of Texas Instruments standard warranty. Production processing does not necessarily include testing of all parameters.

**TEXAS
INSTRUMENTS**

POST OFFICE BOX 655303 • DALLAS, TEXAS 75265

Copyright © 2002, Texas Instruments Incorporated

LM285-2.5, LM385-2.5, LM385B-2.5 MICROPOWER VOLTAGE REFERENCES

SLVS023G – JANUARY 1989 – REVISED NOVEMBER 2002

description/ordering information (continued)

The design makes these devices exceptionally tolerant of capacitive loading and, thus, easier to use in most reference applications. The wide dynamic operating temperature range accommodates varying current supplies, with excellent regulation.

The extremely low power drain of this series makes them useful for micropower circuitry. These voltage references can be used to make portable meters, regulators, or general-purpose analog circuitry, with battery life approaching shelf life. The wide operating current range allows them to replace older references with tighter-tolerance parts.

symbol



schematic

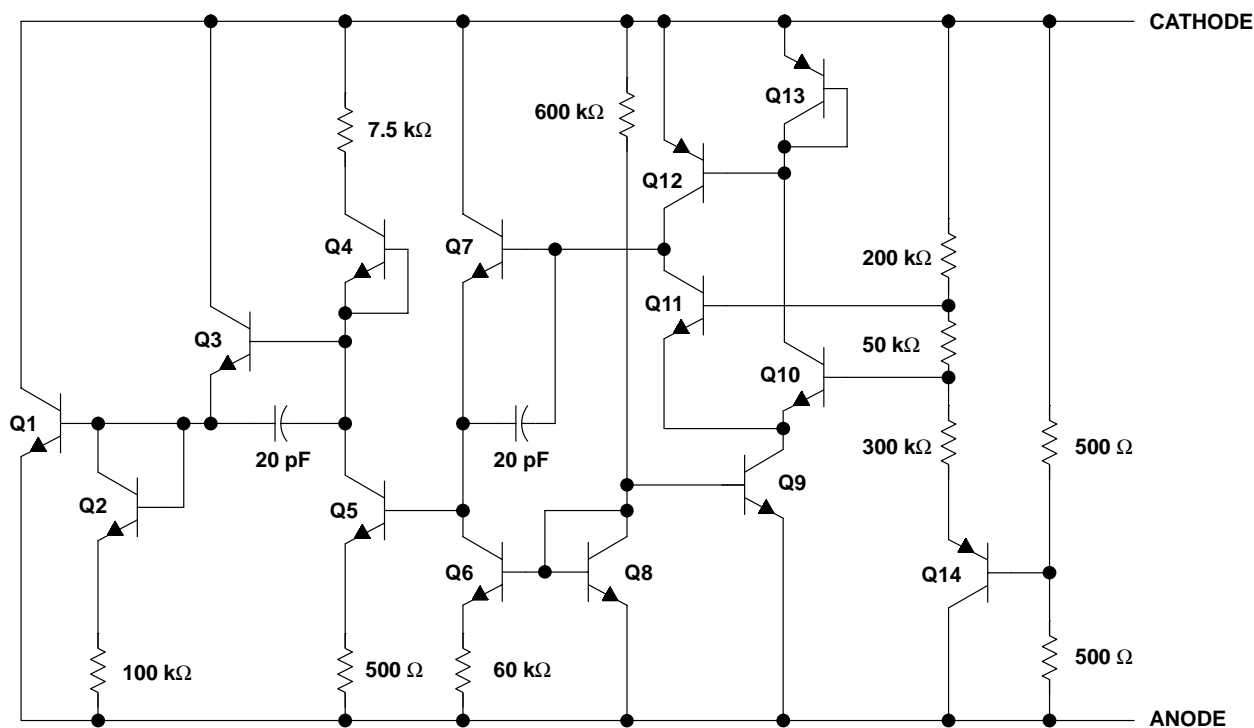

NOTE A: All component values shown are nominal.



POST OFFICE BOX 655303 • DALLAS, TEXAS 75265

LM285-2.5, LM385-2.5, LM385B-2.5 MICROPOWER VOLTAGE REFERENCES

SLVS023G – JANUARY 1989 – REVISED NOVEMBER 2002

absolute maximum ratings over operating free-air temperature range†

Reverse current, I_R	30 mA
Forward current, I_F	10 mA
Package thermal impedance, θ_{JA} (see Notes 1 and 2): D package	97°C/W
LP package	156°C/W
PW package	149°C/W
Lead temperature 1,6 mm (1/16 inch) from case for 10 seconds	260°C
Storage temperature range, T_{stg}	–65°C to 150°C

† Stresses beyond those listed under “absolute maximum ratings” may cause permanent damage to the device. These are stress ratings only, and functional operation of the device at these or any other conditions beyond those indicated under “recommended operating conditions” is not implied. Exposure to absolute-maximum-rated conditions for extended periods may affect device reliability.

- NOTES: 1. Maximum power dissipation is a function of $T_{J(max)}$, θ_{JA} , and T_A . The maximum allowable power dissipation at any allowable ambient temperature is $P_D = (T_{J(max)} - T_A)/\theta_{JA}$. Operation at the absolute maximum T_J of 150°C can affect reliability.
2. The package thermal impedance is calculated in accordance with JESD 51-7.

recommended operating conditions

		MIN	MAX	UNIT
I_Z	Reference current	0.02	20	mA
T_A	Operating free-air temperature range	LM285-2.5	–40	85
		LM385-2.5, LM385B-2.5	0	70

electrical characteristics at specified free-air temperature

PARAMETER	TEST CONDITIONS	T_A ‡	LM285-2.5			LM385-2.5			LM385B-2.5			UNIT	
			MIN	TYP	MAX	MIN	TYP	MAX	MIN	TYP	MAX		
V_Z	Reference voltage	$I_Z = 20 \mu A$ to 20 mA	25°C	2.462	2.5	2.538	2.425	2.5	2.575	2.462	2.5	2.538	V
α_{VZ}	Average temperature coefficient of reference voltage§	$I_Z = 20 \mu A$ to 20 mA	25°C	±20			±20			±20			ppm/°C
ΔV_Z	Change in reference voltage with current	$I_Z = 20 \mu A$ to 1 mA	25°C	1			2			2			mV
			Full range	1.5			2			2			
		$I_Z = 1 \mu A$ to 20 mA	25°C	10			20			20			
			Full range	30			30			30			
$\Delta V_Z/\Delta t$	Long-term change in reference voltage	$I_Z = 100 \mu A$	25°C	±20			±20			±20			ppm/khr
$I_{Z(min)}$	Minimum reference current		Full range	8			8			8			μA
Z_Z	Reference impedance	$I_Z = 100 \mu A$	25°C	0.2			0.4			0.4			Ω
			Full range	1.5			1.5			1.5			
V_n	Broadband noise voltage	$I_Z = 100 \mu A$, $f = 10$ Hz to 10 kHz	25°C	120			120			120			μV

‡ Full range is 0°C to 70°C for the LM385-2.5 and LM385B-2.5, and –40°C to 85°C for the LM285-2.5.

§ The average temperature coefficient of reference voltage is defined as the total change in reference voltage divided by the specified temperature range.



LM285-2.5, LM385-2.5, LM385B-2.5 MICROPOWER VOLTAGE REFERENCES

SLVS023G – JANUARY 1989 – REVISED NOVEMBER 2002

TYPICAL CHARACTERISTICS†

REVERSE CURRENT
vs
REVERSE VOLTAGE

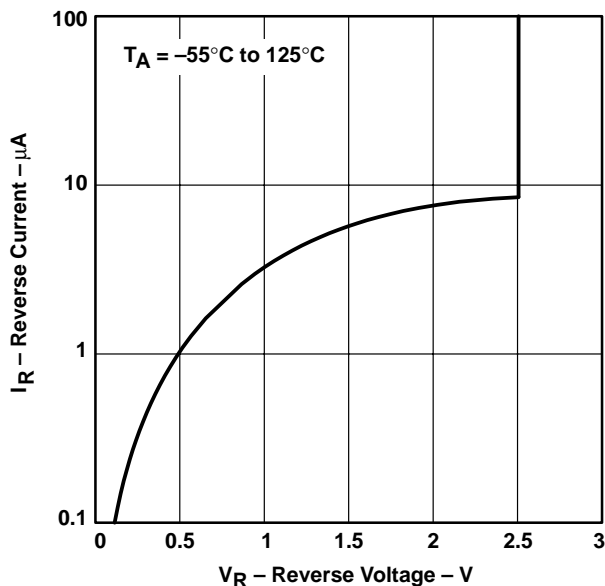

Figure 1

REFERENCE VOLTAGE CHANGE
vs
REVERSE CURRENT

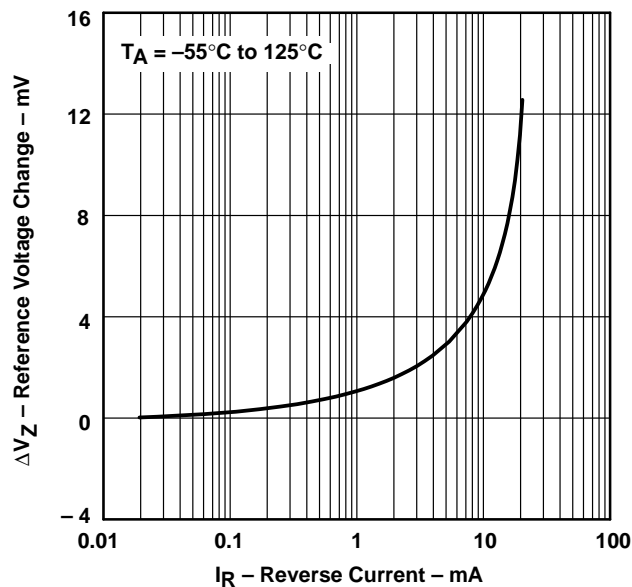

Figure 2

FORWARD VOLTAGE
vs
FORWARD CURRENT

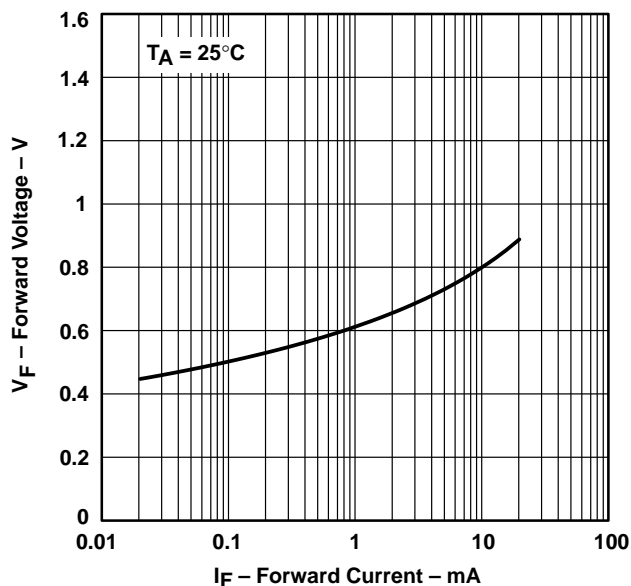

Figure 3

REFERENCE VOLTAGE
vs
FREE-AIR TEMPERATURE

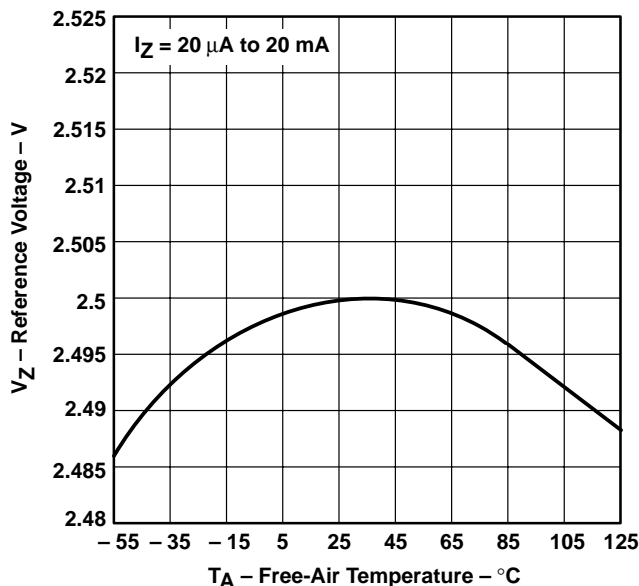

Figure 4

†Data at high and low temperatures are applicable only within the rated operating free-air temperature ranges of the various devices.



TYPICAL CHARACTERISTICS†

REFERENCE IMPEDANCE
VS
REFERENCE CURRENT

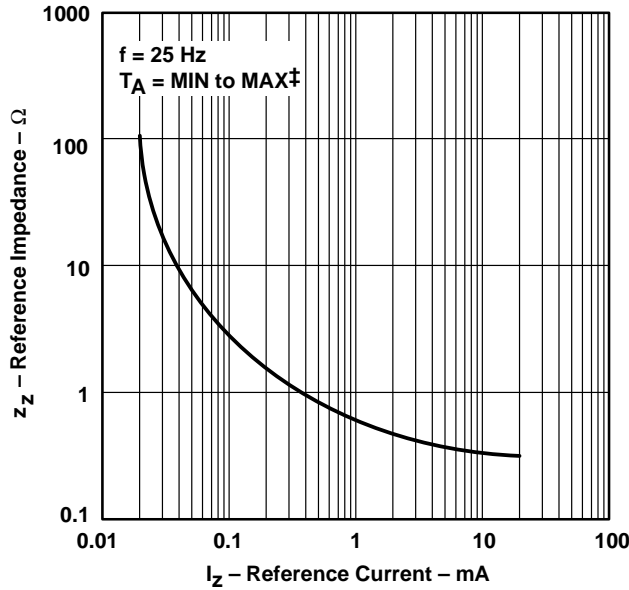

Figure 5

REFERENCE IMPEDANCE
VS
FREQUENCY

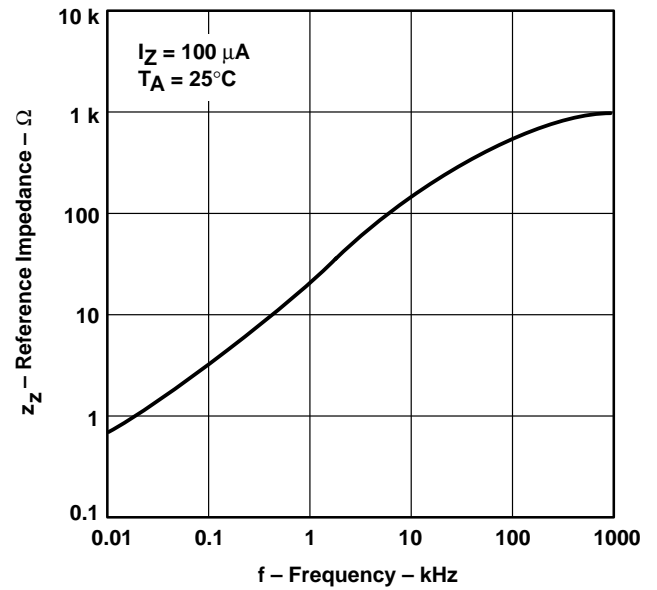

Figure 6

NOISE VOLTAGE
VS
FREQUENCY

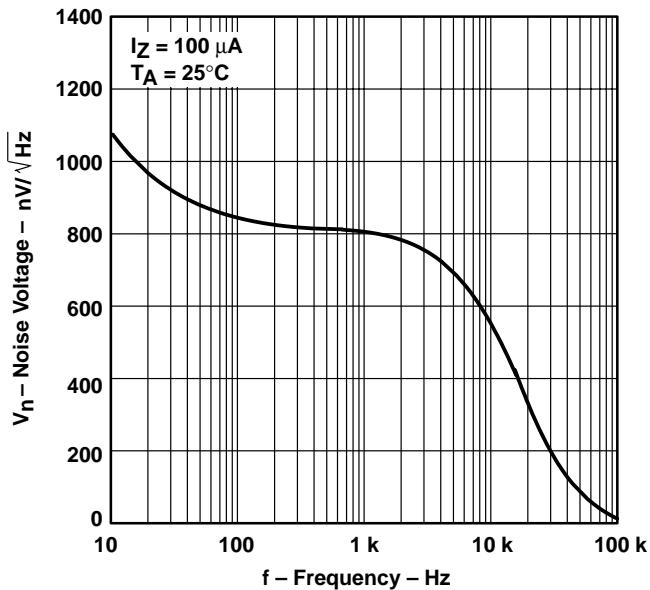

Figure 7

FILTERED RMS OUTPUT NOISE VOLTAGE
VS
FREQUENCY

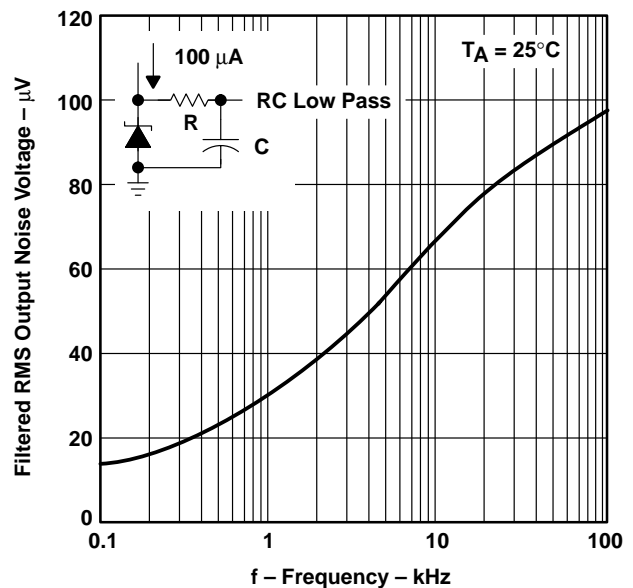

Figure 8

†Data at high and low temperatures are applicable only within the rated operating free-air temperature ranges of the various devices.
‡For conditions shown as MIN or MAX, use the appropriate value specified under recommended operating conditions.

LM285-2.5, LM385-2.5, LM385B-2.5 MICROPOWER VOLTAGE REFERENCES

SLVS023G – JANUARY 1989 – REVISED NOVEMBER 2002

TYPICAL CHARACTERISTICS†

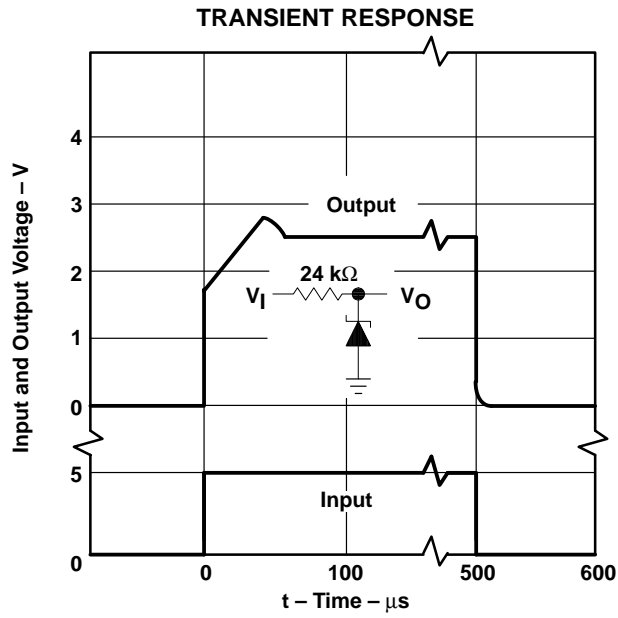
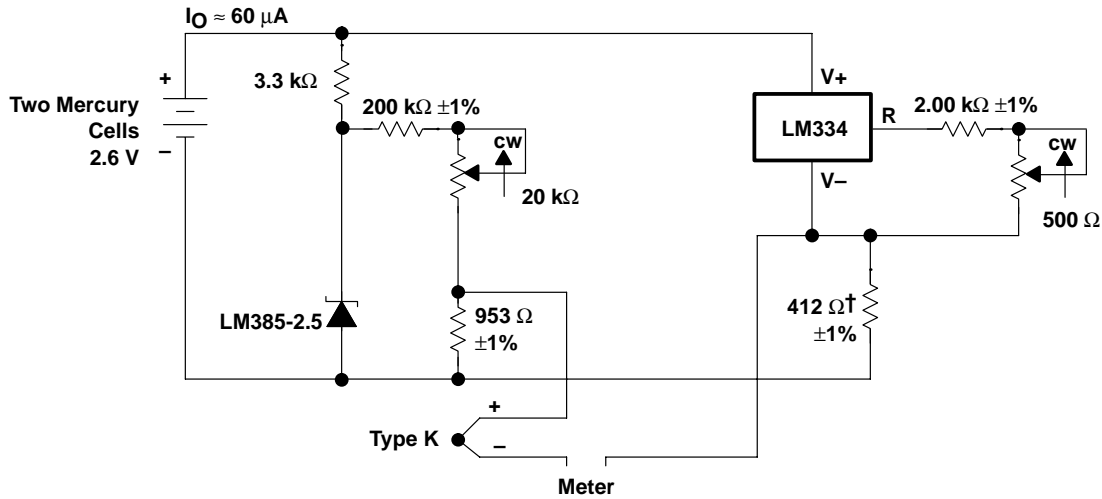

Figure 9

†Data at high and low temperatures are applicable only within the rated operating free-air temperature ranges of the various devices.

APPLICATION INFORMATION



†Adjust for 12.17 mV at 25°C across 412 Ω

Figure 10. Thermocouple Cold-Junction Compensator

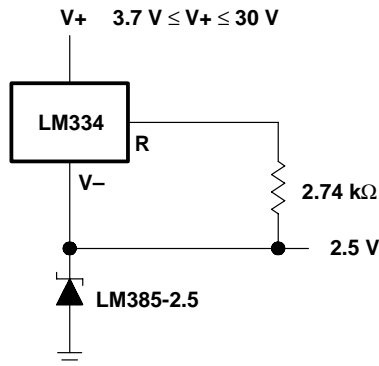

Figure 11. Operation Over a Wide Supply Range

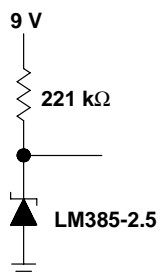
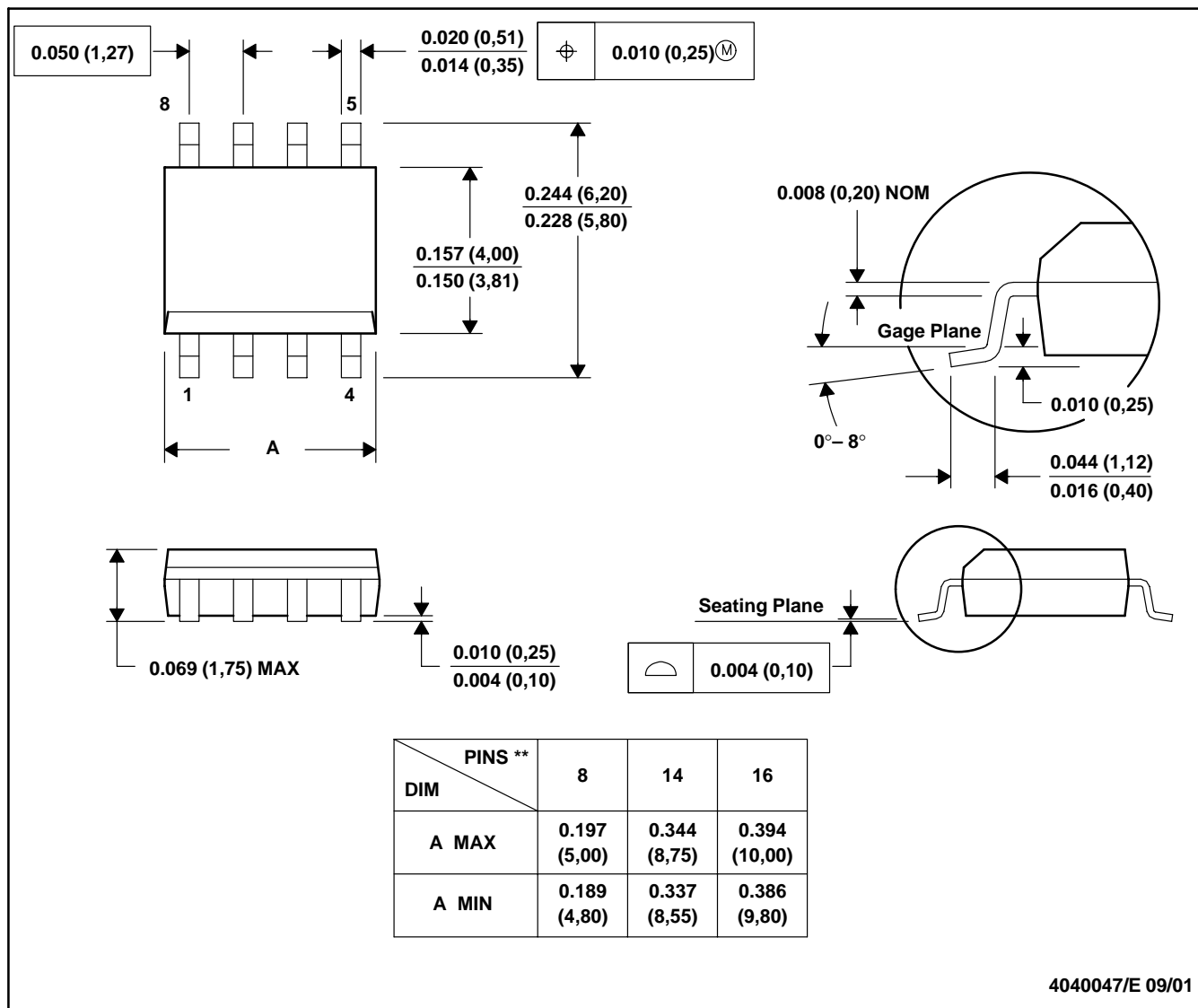

Figure 12. Reference From a 9-V Battery

D (R-PDSO-G**)

PLASTIC SMALL-OUTLINE PACKAGE

8 PINS SHOWN



- NOTES: A. All linear dimensions are in inches (millimeters).
 B. This drawing is subject to change without notice.
 C. Body dimensions do not include mold flash or protrusion, not to exceed 0.006 (0,15).
 D. Falls within JEDEC MS-012

LP (O-PBCY-W3)

PLASTIC CYLINDRICAL PACKAGE

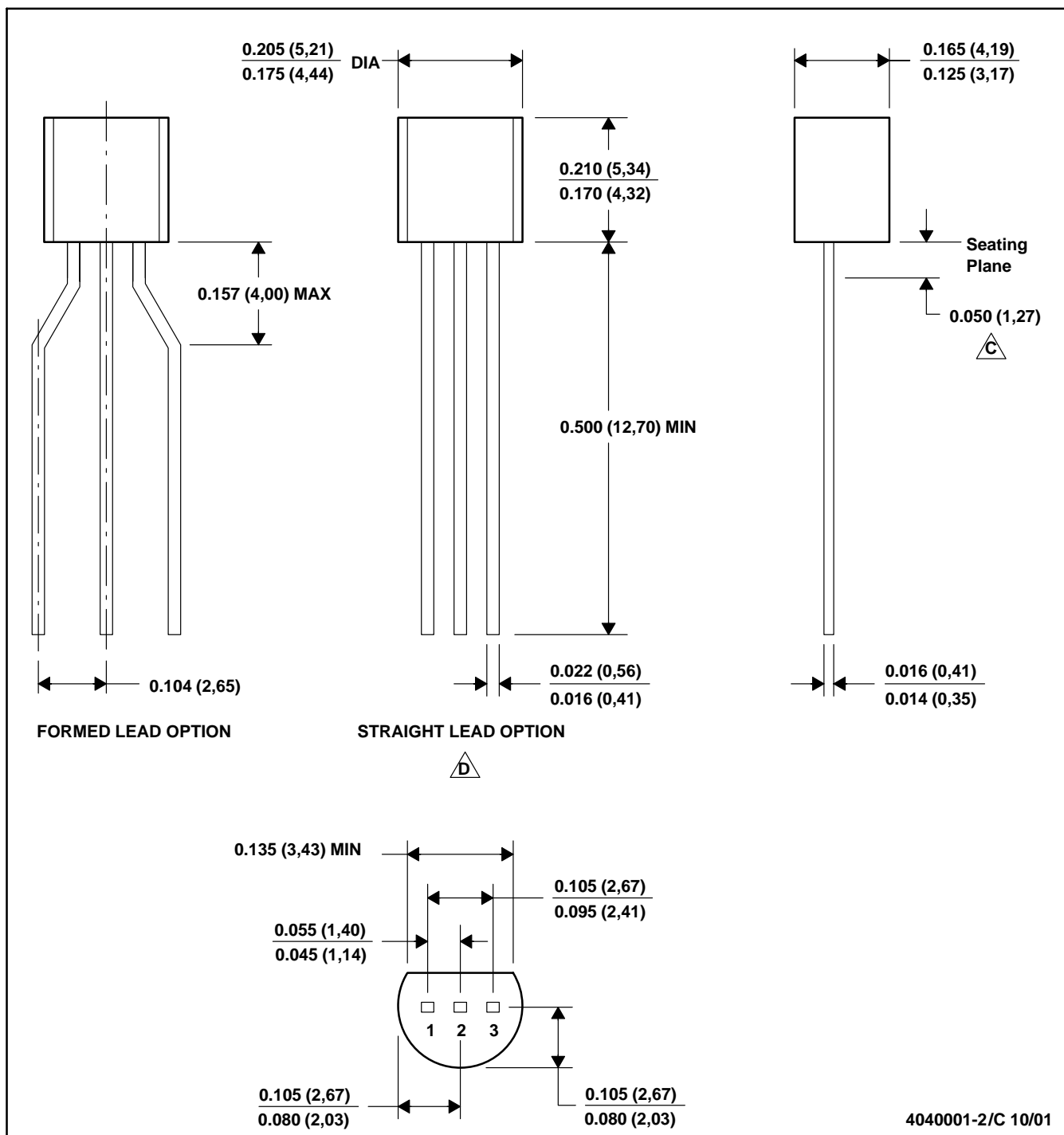

- NOTES: A. All linear dimensions are in inches (millimeters).
 B. This drawing is subject to change without notice.
 C. Lead dimensions are not controlled within this area
 D. Falls within JEDEC TO -226 Variation AA (TO-226 replaces TO-92)
 E. Shipping Method:
 Straight lead option available in bulk pack only.
 Formed lead option available in tape & reel or ammo pack.

MECHANICAL DATA

MSOT002A – OCTOBER 1994 – REVISED NOVEMBER 2001

LP (O-PBCY-W3)

PLASTIC CYLINDRICAL PACKAGE

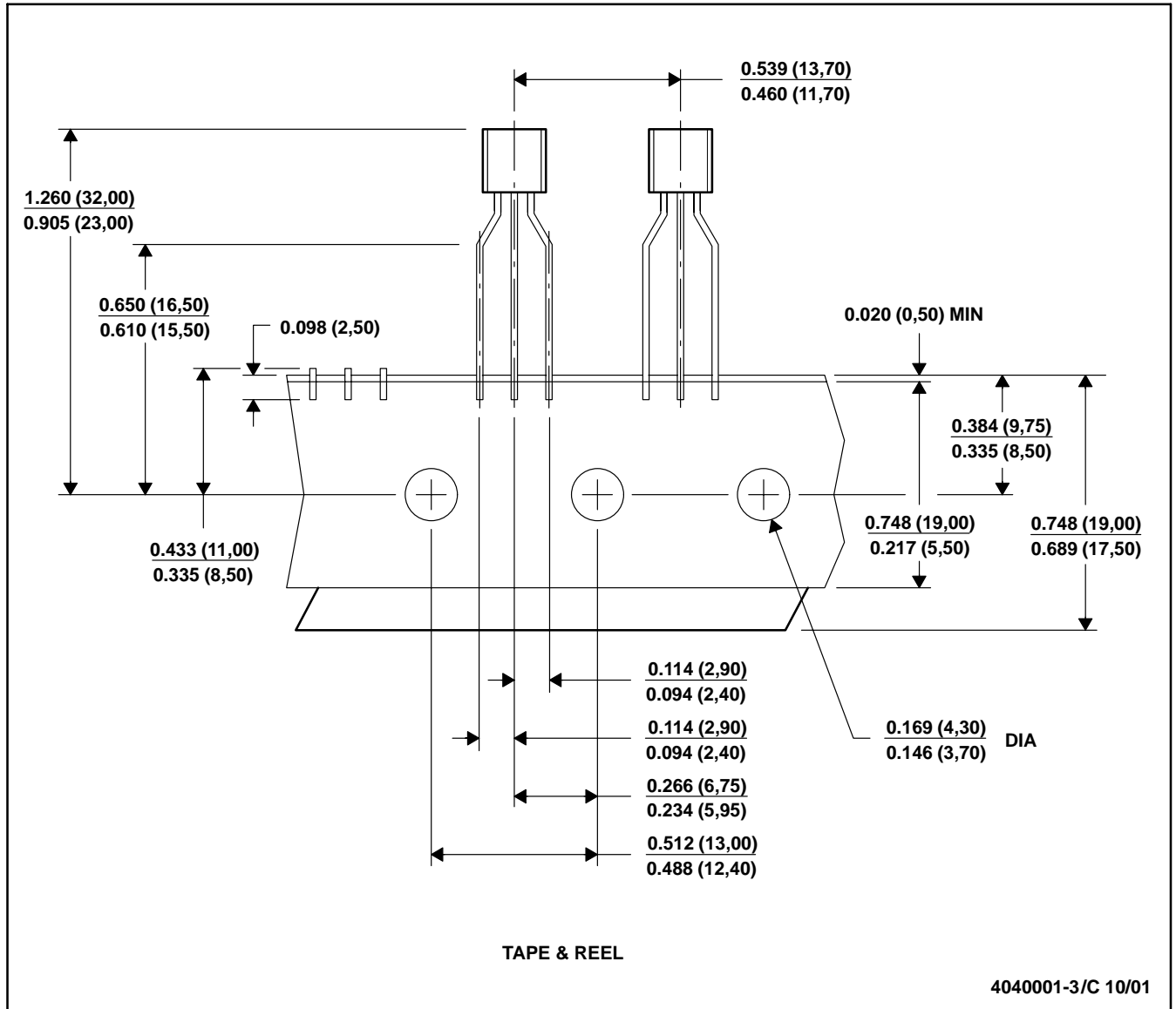

- NOTES:
- All linear dimensions are in inches (millimeters).
 - This drawing is subject to change without notice.
 - Tape and Reel information for the Format Lead Option package.

PW (R-PDSO-G**)

PLASTIC SMALL-OUTLINE PACKAGE

14 PINS SHOWN



4040064/F 01/97

- NOTES: A. All linear dimensions are in millimeters.
 B. This drawing is subject to change without notice.
 C. Body dimensions do not include mold flash or protrusion not to exceed 0,15.
 D. Falls within JEDEC MO-153

IMPORTANT NOTICE

Texas Instruments Incorporated and its subsidiaries (TI) reserve the right to make corrections, modifications, enhancements, improvements, and other changes to its products and services at any time and to discontinue any product or service without notice. Customers should obtain the latest relevant information before placing orders and should verify that such information is current and complete. All products are sold subject to TI's terms and conditions of sale supplied at the time of order acknowledgment.

TI warrants performance of its hardware products to the specifications applicable at the time of sale in accordance with TI's standard warranty. Testing and other quality control techniques are used to the extent TI deems necessary to support this warranty. Except where mandated by government requirements, testing of all parameters of each product is not necessarily performed.

TI assumes no liability for applications assistance or customer product design. Customers are responsible for their products and applications using TI components. To minimize the risks associated with customer products and applications, customers should provide adequate design and operating safeguards.

TI does not warrant or represent that any license, either express or implied, is granted under any TI patent right, copyright, mask work right, or other TI intellectual property right relating to any combination, machine, or process in which TI products or services are used. Information published by TI regarding third-party products or services does not constitute a license from TI to use such products or services or a warranty or endorsement thereof. Use of such information may require a license from a third party under the patents or other intellectual property of the third party, or a license from TI under the patents or other intellectual property of TI.

Reproduction of information in TI data books or data sheets is permissible only if reproduction is without alteration and is accompanied by all associated warranties, conditions, limitations, and notices. Reproduction of this information with alteration is an unfair and deceptive business practice. TI is not responsible or liable for such altered documentation.

Resale of TI products or services with statements different from or beyond the parameters stated by TI for that product or service voids all express and any implied warranties for the associated TI product or service and is an unfair and deceptive business practice. TI is not responsible or liable for any such statements.

Mailing Address:

Texas Instruments
Post Office Box 655303
Dallas, Texas 75265