

LM833-N Dual Audio Operational Amplifier

Check for Samples: [LM833-N](#)

FEATURES

- **Wide Dynamic Range:** >140dB
- **Low Input Noise Voltage:** $4.5\text{nV}/\sqrt{\text{Hz}}$
- **High Slew Rate:** $7\text{ V}/\mu\text{s}$ (typ); $5\text{ V}/\mu\text{s}$ (Min)
- **High Gain Bandwidth:** 15MHz (typ); 10MHz (Min)
- **Wide Power Bandwidth:** 120KHz
- **Low Distortion:** 0.002%
- **Low Offset Voltage:** 0.3mV
- **Large Phase Margin:** 60°
- **Available in 8 Pin VSSOP Package**

DESCRIPTION

The LM833-N is a dual general purpose operational amplifier designed with particular emphasis on performance in audio systems.

This dual amplifier IC utilizes new circuit and processing techniques to deliver low noise, high speed and wide bandwidth without increasing external components or decreasing stability. The LM833-N is internally compensated for all closed loop gains and is therefore optimized for all preamp and high level stages in PCM and HiFi systems.

The LM833-N is pin-for-pin compatible with industry standard dual operational amplifiers.

Schematic Diagram

(1/2 LM833-N)

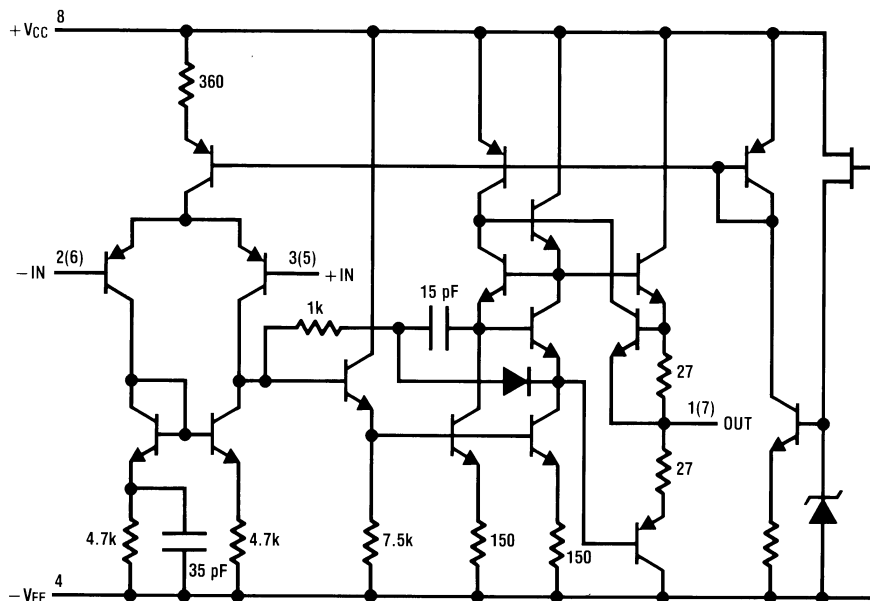

Please be aware that an important notice concerning availability, standard warranty, and use in critical applications of Texas Instruments semiconductor products and disclaimers thereto appears at the end of this data sheet.

All trademarks are the property of their respective owners.

Connection Diagram

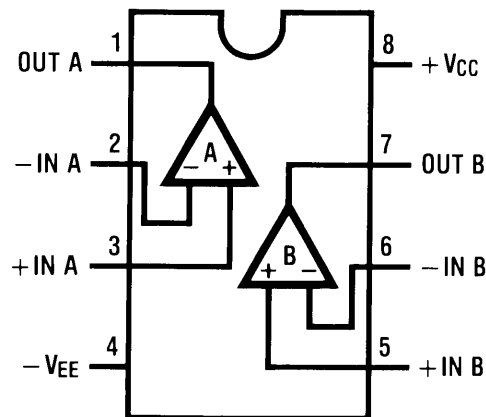

Figure 1. See Package Number D0008A, P0008E or DGK0008A



These devices have limited built-in ESD protection. The leads should be shorted together or the device placed in conductive foam during storage or handling to prevent electrostatic damage to the MOS gates.

ABSOLUTE MAXIMUM RATINGS⁽¹⁾⁽²⁾

Supply Voltage $V_{CC}-V_{EE}$		36V	
Differential Input Voltage ⁽³⁾ V_I		$\pm 30V$	
Input Voltage Range ⁽³⁾ V_{IC}		$\pm 15V$	
Power Dissipation ⁽⁴⁾ P_D		500 mW	
Operating Temperature Range T_{OPR}		$-40 \sim 85^\circ C$	
Storage Temperature Range T_{STG}		$-60 \sim 150^\circ C$	
Soldering Information	PDIP Package	Soldering (10 seconds)	260°C
	Small Outline Package (SOIC and VSSOP)	Vapor Phase (60 seconds)	215°C
		Infrared (15 seconds)	220°C
ESD tolerance ⁽⁵⁾		1600V	

- (1) *Absolute Maximum Ratings* indicate limits beyond which damage to the device may occur. *Operating Ratings* indicate conditions for which the device is functional, but do not ensure specific performance limits. *Electrical Characteristics* state DC and AC electrical specifications under particular test conditions which ensure specific performance limits. This assumes that the device is within the Operating Ratings. Specifications are not ensured for parameters where no limit is given, however, the typical value is a good indication of device performance.
- (2) If Military/Aerospace specified devices are required, please contact the Texas Instruments Sales Office/ Distributors for availability and specifications.
- (3) If supply voltage is less than $\pm 15V$, it is equal to supply voltage.
- (4) This is the permissible value at $T_A \leq 85^\circ C$.
- (5) Human body model, 1.5 k Ω in series with 100 pF.

DC ELECTRICAL CHARACTERISTICS⁽¹⁾⁽²⁾

 $(T_A = 25^\circ\text{C}, V_S = \pm 15\text{V})$

Symbol	Parameter	Conditions	Min	Typ	Max	Units
V_{OS}	Input Offset Voltage	$R_S = 10\Omega$		0.3	5	mV
I_{OS}	Input Offset Current			10	200	nA
I_B	Input Bias Current			500	1000	nA
A_V	Voltage Gain	$R_L = 2\text{ k}\Omega, V_O = \pm 10\text{V}$	90	110		dB
V_{OM}	Output Voltage Swing	$R_L = 10\text{ k}\Omega$	± 12	± 13.5		V
		$R_L = 2\text{ k}\Omega$	± 12	± 13.4		V
V_{CM}	Input Common-Mode Range		± 12	± 14.0		V
CMRR	Common-Mode Rejection Ratio	$V_{IN} = \pm 12\text{V}$	80	100		dB
PSRR	Power Supply Rejection Ratio	$V_S = 15 \sim 5\text{V}, -15 \sim -5\text{V}$	80	100		dB
I_Q	Supply Current	$V_O = 0\text{V}$, Both Amps		5	8	mA

- (1) *Absolute Maximum Ratings* indicate limits beyond which damage to the device may occur. *Operating Ratings* indicate conditions for which the device is functional, but do not ensure specific performance limits. *Electrical Characteristics* state DC and AC electrical specifications under particular test conditions which ensure specific performance limits. This assumes that the device is within the Operating Ratings. Specifications are not ensured for parameters where no limit is given, however, the typical value is a good indication of device performance.
- (2) All voltages are measured with respect to the ground pin, unless otherwise specified.

AC ELECTRICAL CHARACTERISTICS

 $(T_A = 25^\circ\text{C}, V_S = \pm 15\text{V}, R_L = 2\text{ k}\Omega)$

Symbol	Parameter	Conditions	Min	Typ	Max	Units
SR	Slew Rate	$R_L = 2\text{ k}\Omega$	5	7		V/ μs
GBW	Gain Bandwidth Product	$f = 100\text{ kHz}$	10	15		MHz
V_{NI}	Equivalent Input Noise Voltage (LM833AM, LM833AMX)	RIAA, $R_S = 2.2\text{ k}\Omega$ ⁽¹⁾			1.4	μV

- (1) RIAA Noise Voltage Measurement Circuit

DESIGN ELECTRICAL CHARACTERISTICS

 $(T_A = 25^\circ\text{C}, V_S = \pm 15\text{V})$

The following parameters are not tested or ensured.

Symbol	Parameter	Conditions	Typ	Units
$\Delta V_{OS}/\Delta T$	Average Temperature Coefficient of Input Offset Voltage		2	$\mu\text{V}/^\circ\text{C}$
THD	Distortion	$R_L = 2\text{ k}\Omega, f = 20\sim 20\text{ kHz}$ $V_{OUT} = 3\text{ V}_{rms}, A_V = 1$	0.002	%
e_n	Input Referred Noise Voltage	$R_S = 100\Omega, f = 1\text{ kHz}$	4.5	$\text{nV} / \sqrt{\text{Hz}}$
i_n	Input Referred Noise Current	$f = 1\text{ kHz}$	0.7	$\text{pA} / \sqrt{\text{Hz}}$
PBW	Power Bandwidth	$V_O = 27\text{ V}_{pp}, R_L = 2\text{ k}\Omega, \text{THD} \leq 1\%$	120	kHz
f_U	Unity Gain Frequency	Open Loop	9	MHz
Φ_M	Phase Margin	Open Loop	60	deg
	Input Referred Cross Talk	$f = 20\sim 20\text{ kHz}$	-120	dB

TYPICAL PERFORMANCE CHARACTERISTICS

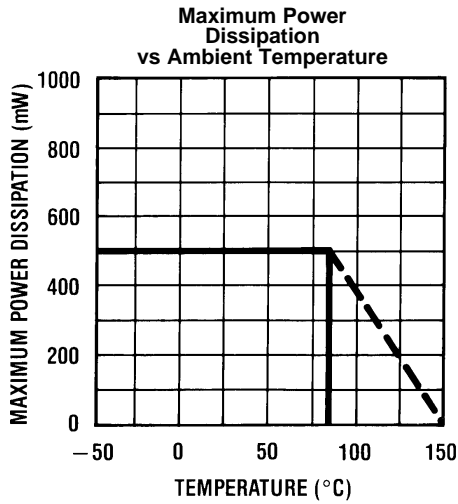

Figure 2.

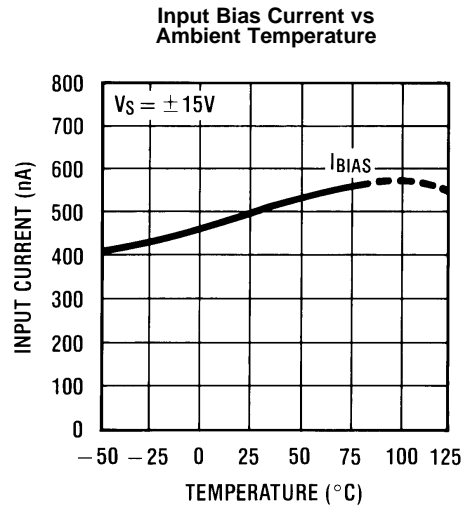

Figure 3.

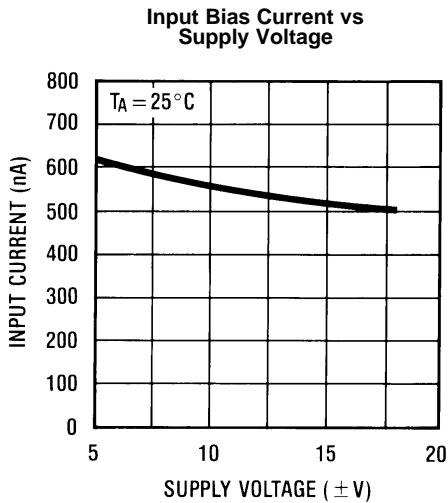

Figure 4.

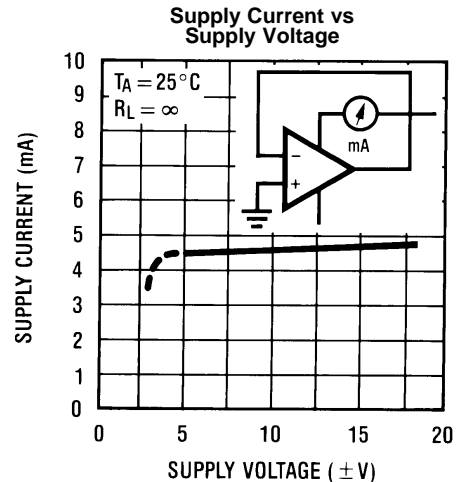

Figure 5.

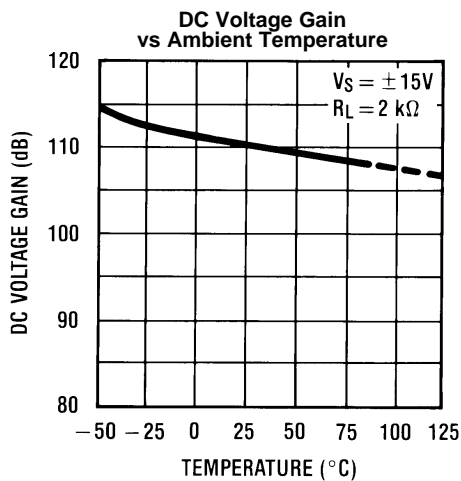

Figure 6.

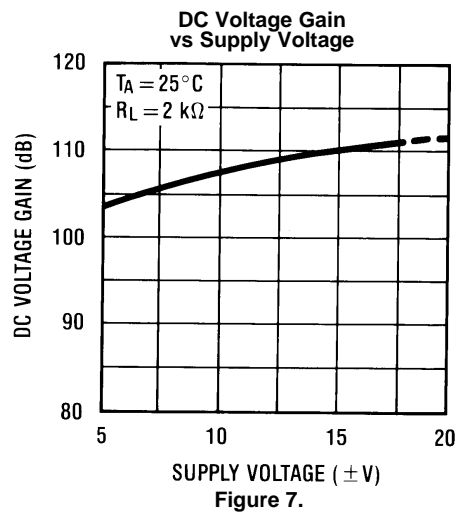
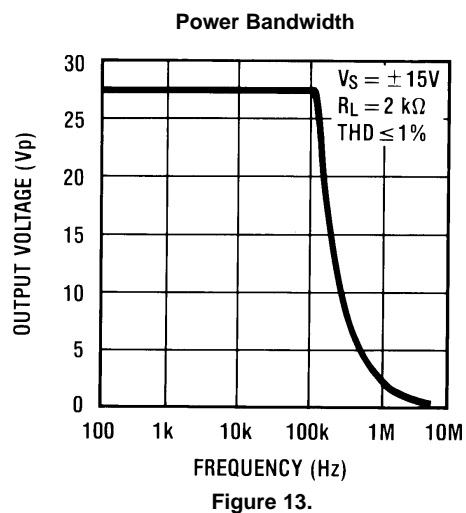
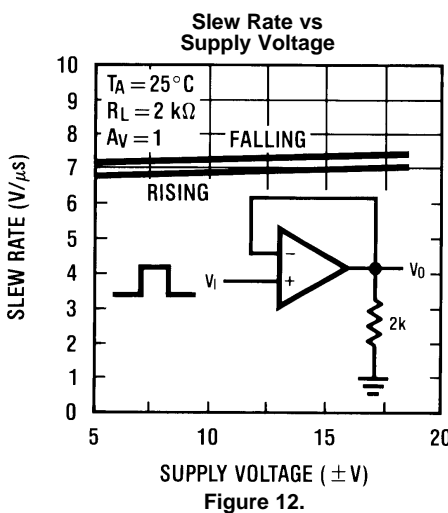
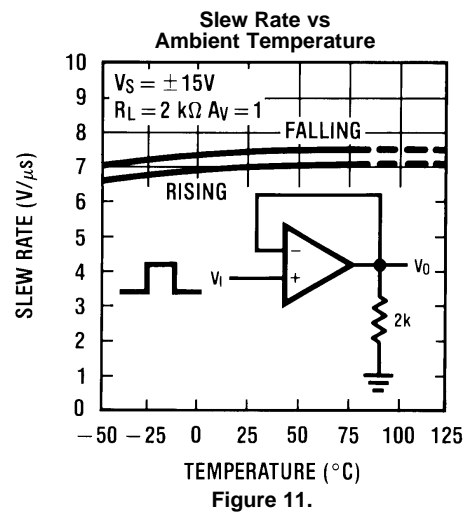
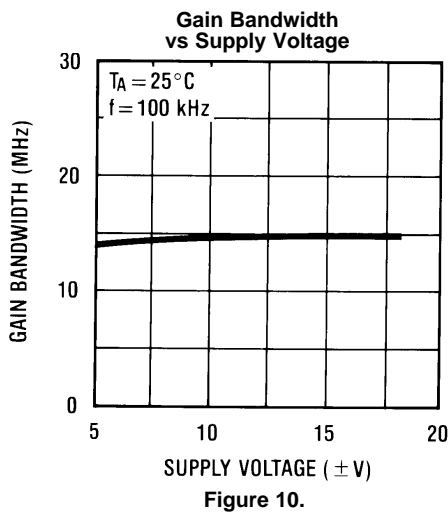
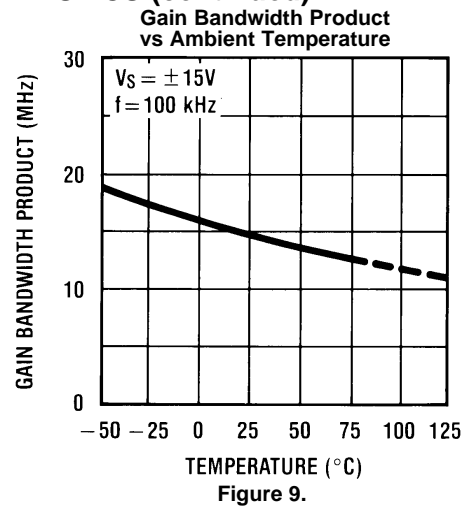
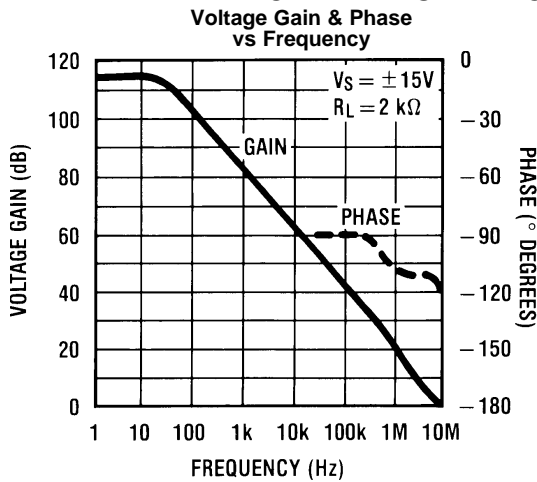
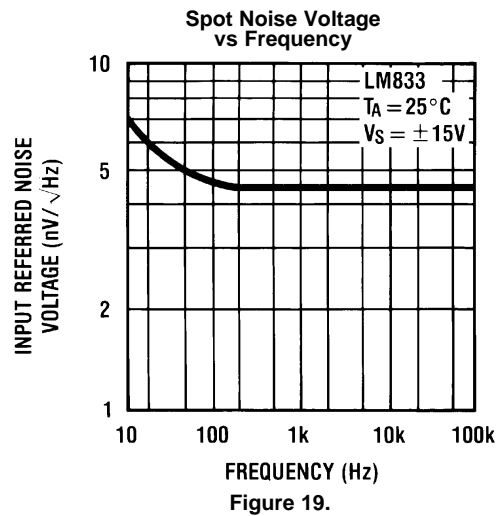
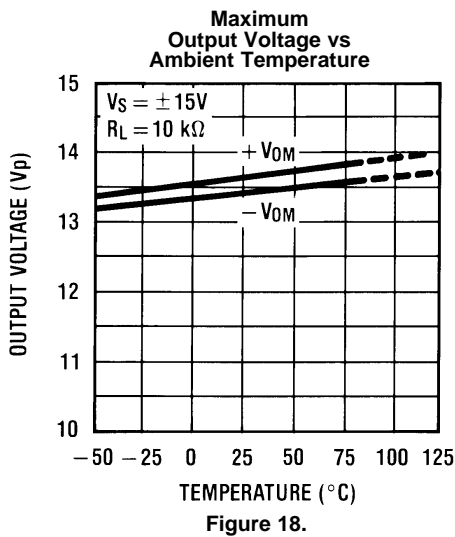
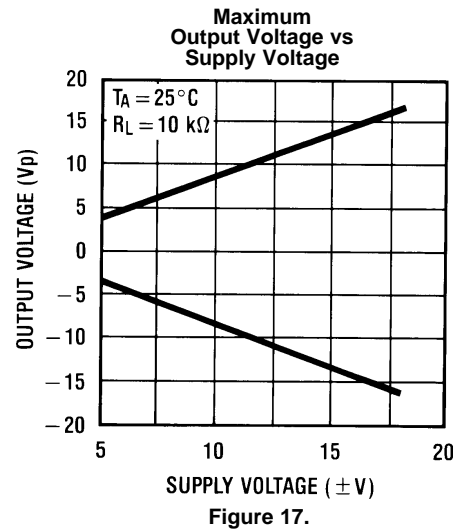
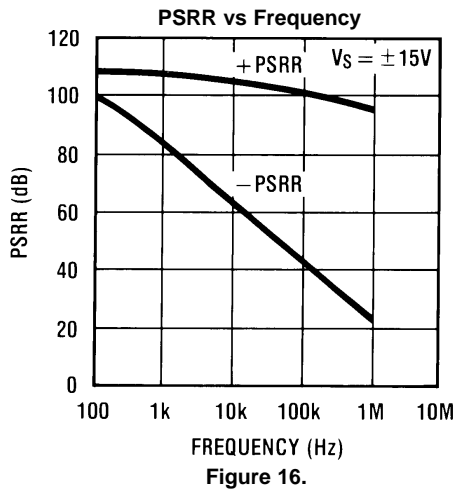
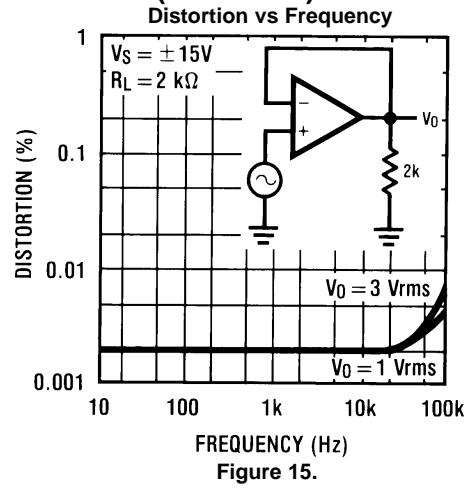
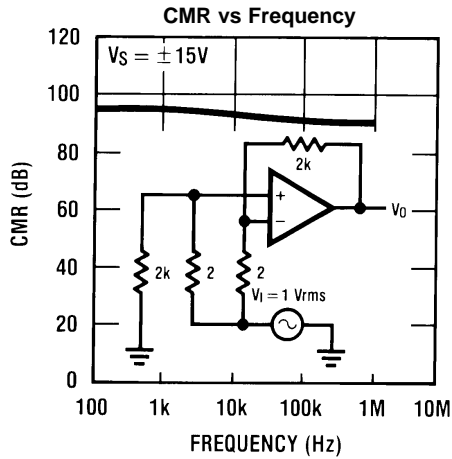

Figure 7.

TYPICAL PERFORMANCE CHARACTERISTICS (continued)



TYPICAL PERFORMANCE CHARACTERISTICS (continued)



TYPICAL PERFORMANCE CHARACTERISTICS (continued)

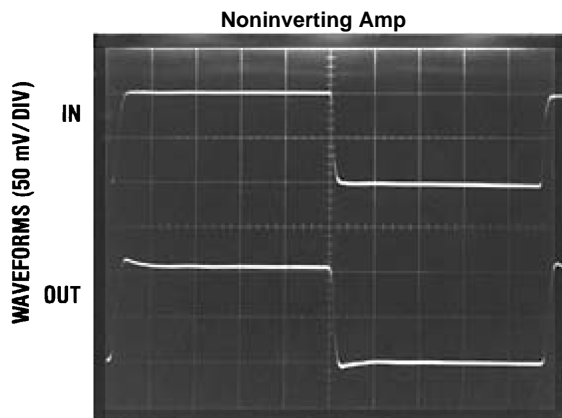
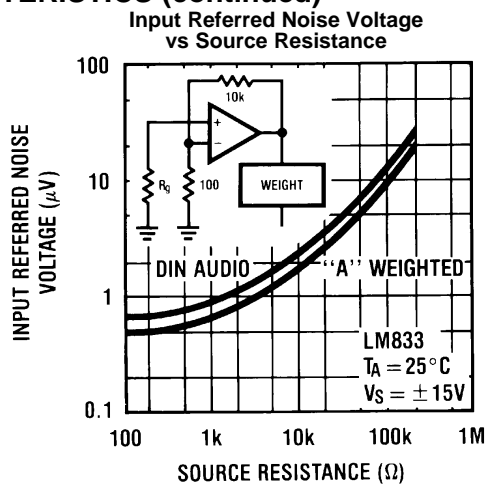
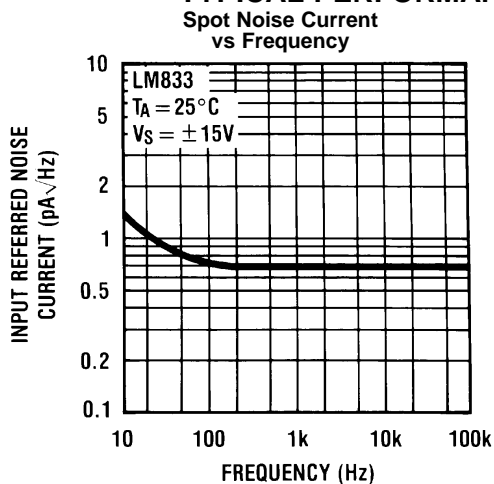

TIME (0.2 μs/DIV)

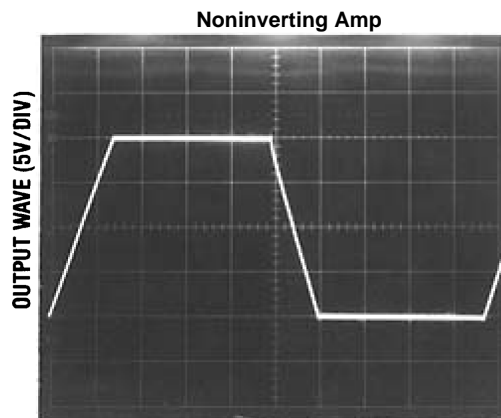

TIME (2 μs/DIV)

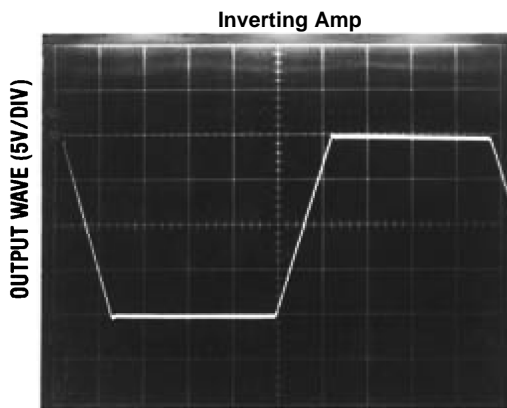

TIME (2 μs/DIV)

APPLICATION HINTS

The LM833-N is a high speed op amp with excellent phase margin and stability. Capacitive loads up to 50 pF will cause little change in the phase characteristics of the amplifiers and are therefore allowable.

Capacitive loads greater than 50 pF must be isolated from the output. The most straightforward way to do this is to put a resistor in series with the output. This resistor will also prevent excess power dissipation if the output is accidentally shorted.

Noise Measurement Circuit

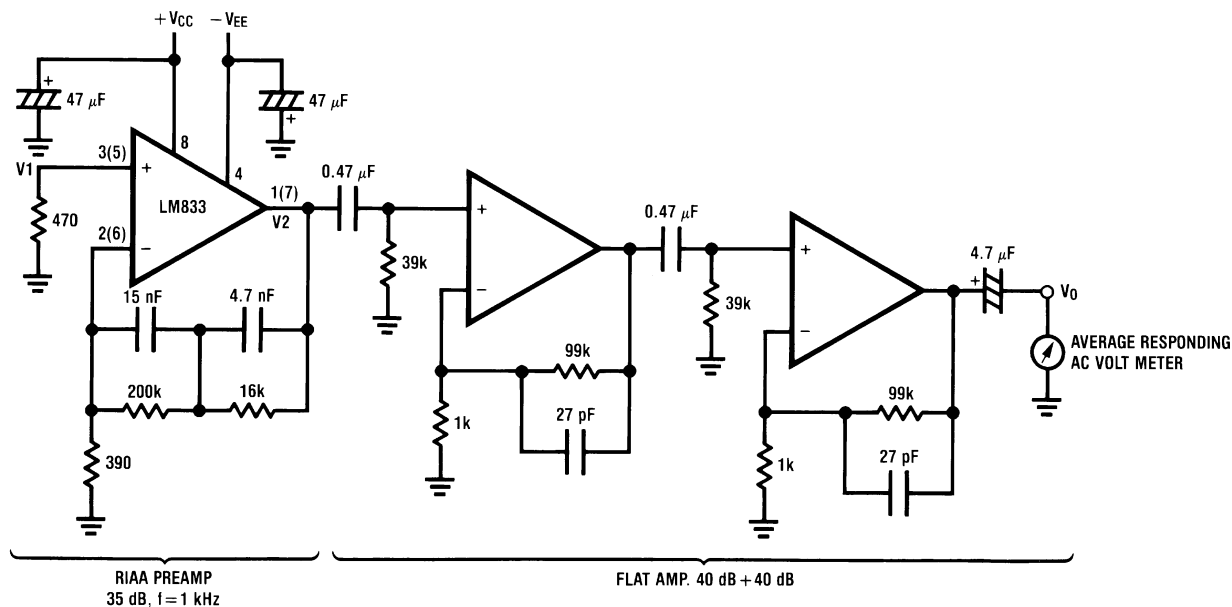

Complete shielding is required to prevent induced pick up from external sources. Always check with oscilloscope for power line noise.

**Figure 25. Total Gain: 115 dB @f = 1 kHz
Input Referred Noise Voltage: $e_n = V_0/560,000$ (V)**

RIAA Noise Voltage Measurement Circuit

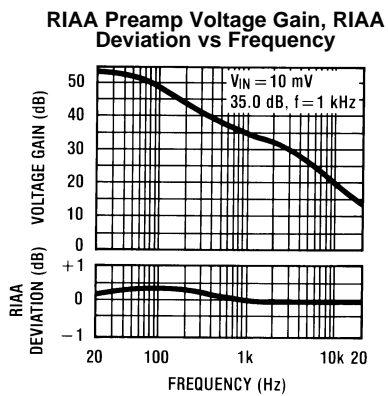
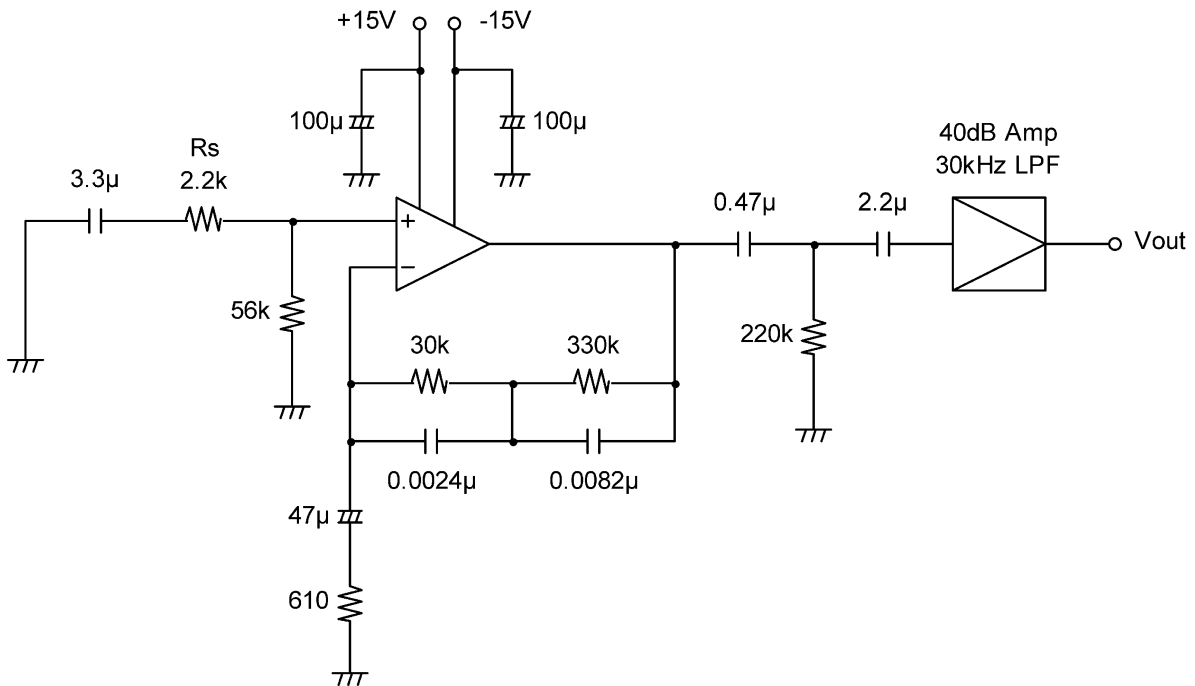

Figure 26.

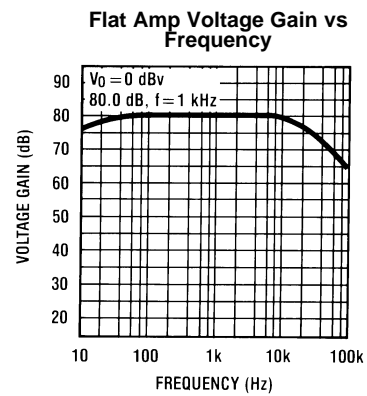
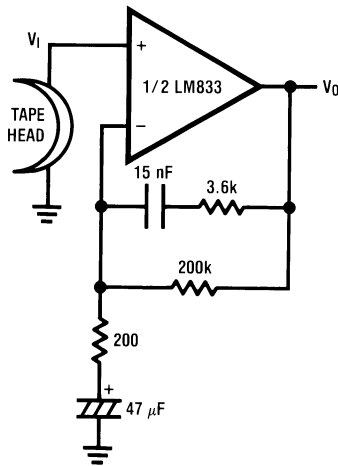

Figure 27.

Typical Applications



$A_V = 34.5$
 $F = 1 \text{ kHz}$
 $E_n = 0.38 \mu\text{V}$
 A Weighted

Figure 28. NAB Preamp

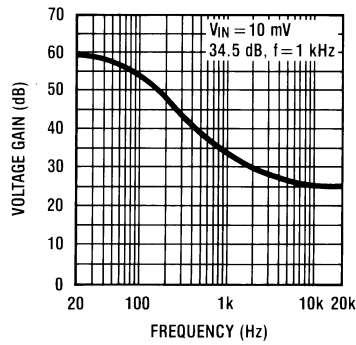
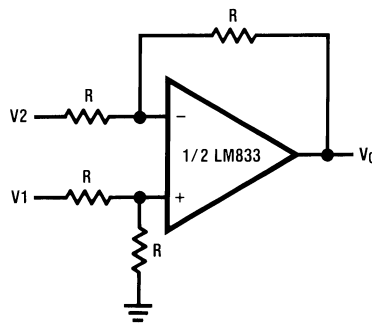
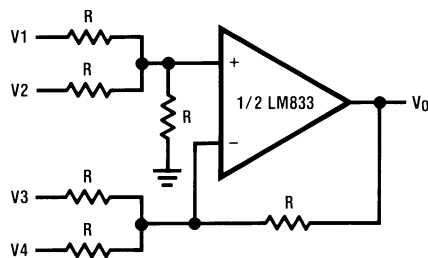

Figure 29. NAB Preamp Voltage Gain vs Frequency



$V_O = V1 - V2$

Figure 30. Balanced to Single Ended Converter



$$V_O = V_1 + V_2 - V_3 - V_4$$

Figure 31. Adder/Subtracter

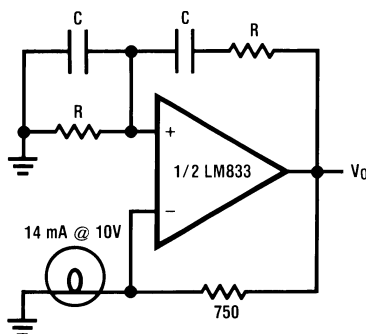

$$f_o = \frac{1}{2\pi RC}$$

Figure 32. Sine Wave Oscillator

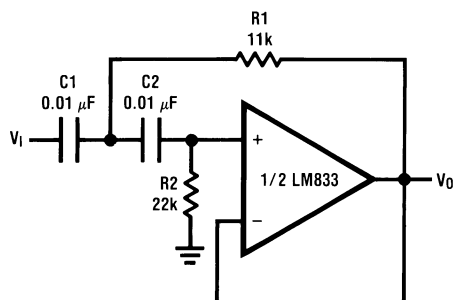

if $C_1 = C_2 = C$

$$R_1 = \frac{\sqrt{2}}{2\omega_0 C}$$

$$R_2 = 2 \cdot R_1$$

Illustration is $f_0 = 1 \text{ kHz}$

Figure 33. Second Order High Pass Filter (Butterworth)

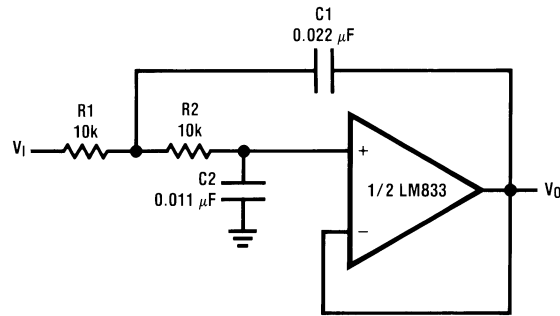

if $R1 = R2 = R$

$$C1 = \frac{\sqrt{2}}{\omega_0 R}$$

$$C2 = \frac{C1}{2}$$

Illustration is $f_0 = 1 \text{ kHz}$

Figure 34. Second Order Low Pass Filter (Butterworth)

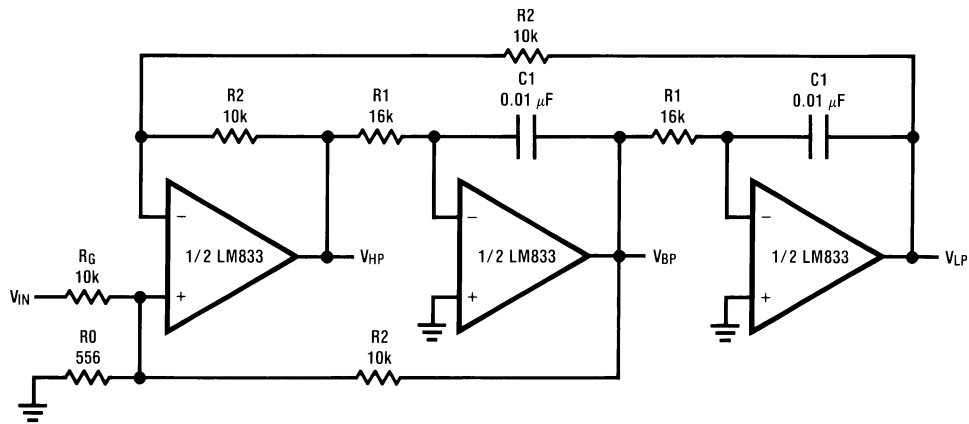

$$f_0 = \frac{1}{2\pi C1 R1}, Q = \frac{1}{2} \left(1 + \frac{R2}{R0} + \frac{R2}{RG} \right), A_{BP} = QA_{LP} = QA_{LH} = \frac{R2}{RG}$$

Illustration is $f_0 = 1 \text{ kHz}, Q = 10, A_{BP} = 1$

Figure 35. State Variable Filter

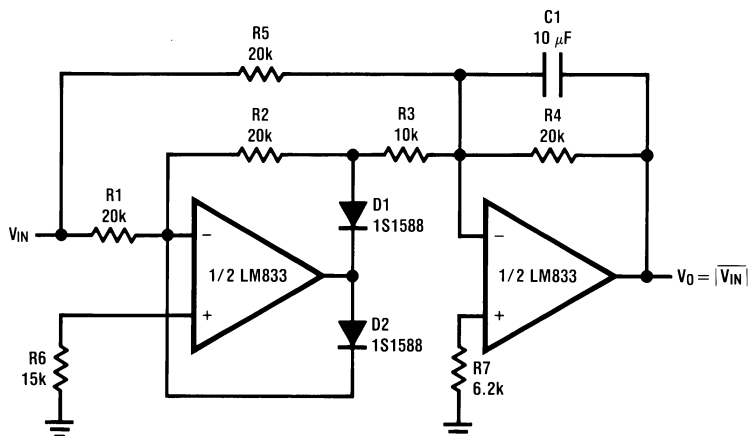

Figure 36. AC/DC Converter

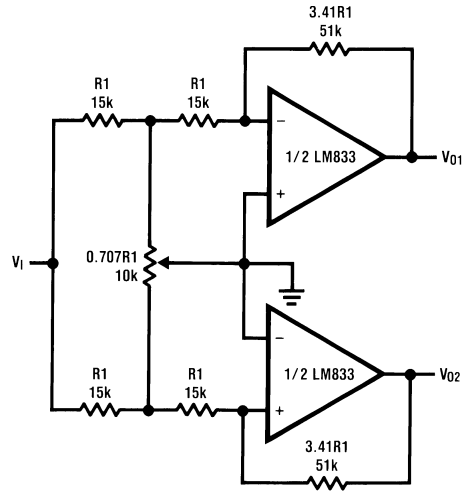

Figure 37. 2 Channel Panning Circuit (Pan Pot)

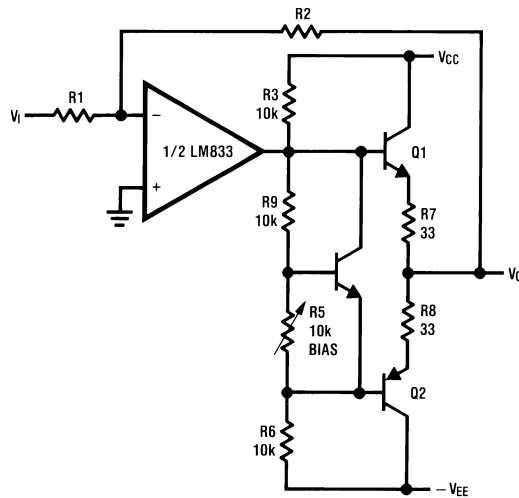
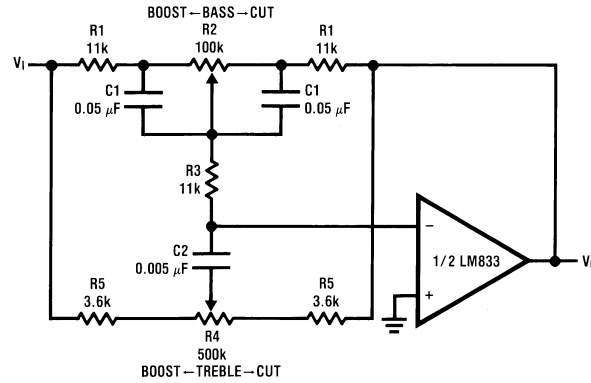

Figure 38. Line Driver



$$f_L = \frac{1}{2\pi R_2 C_1}, f_{LB} = \frac{1}{2\pi R_1 C_1}$$

$$f_H = \frac{1}{2\pi R_5 C_2}, f_{HB} = \frac{1}{2\pi (R_1 + R_5 + 2R_3) C_2}$$

Illustration is:

$f_L = 32 \text{ Hz}$, $f_{LB} = 320 \text{ Hz}$
 $f_H = 11 \text{ kHz}$, $f_{HB} = 1.1 \text{ kHz}$

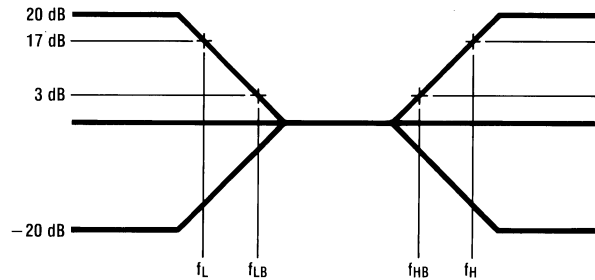
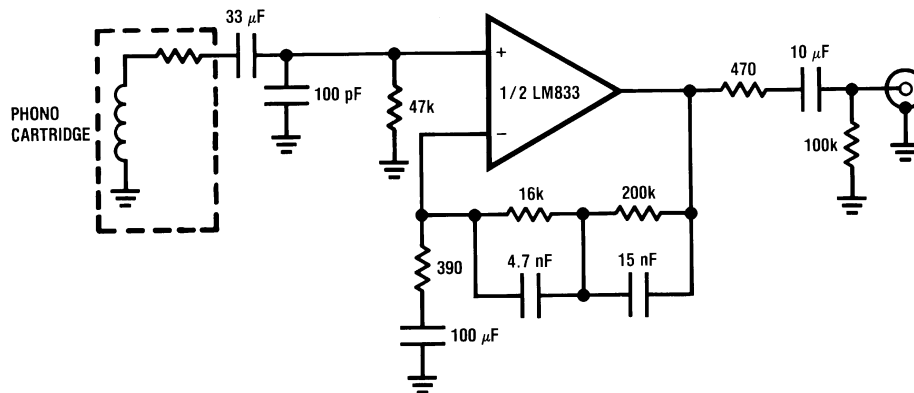
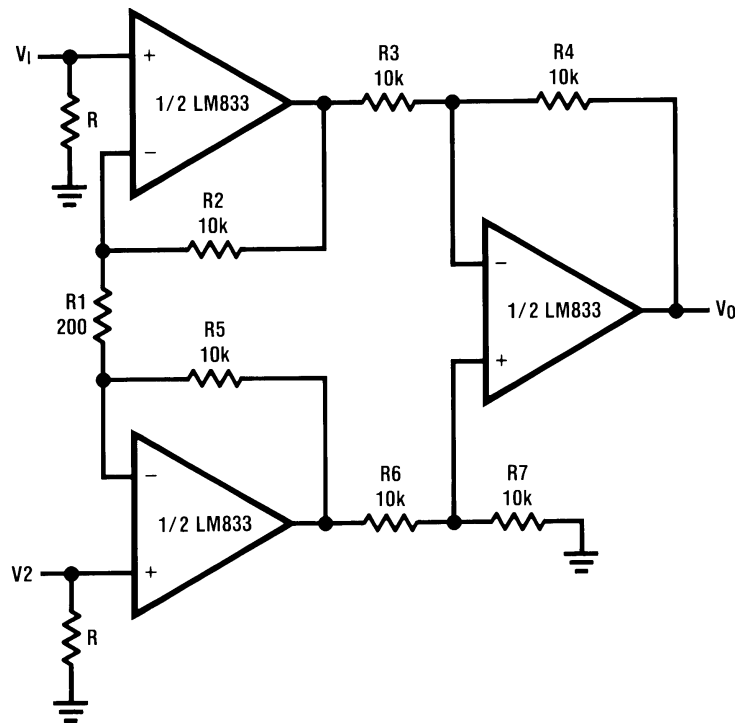

Figure 39. Tone Control



$A_v = 35 \text{ dB}$
 $E_n = 0.33 \mu\text{V}$
 $S/N = 90 \text{ dB}$
 $f = 1 \text{ kHz}$
 A Weighted
 A Weighted, $V_{IN} = 10 \text{ mV}$
 @ $f = 1 \text{ kHz}$

Figure 40. RIAA Preamp



If $R_2 = R_5$, $R_3 = R_6$, $R_4 = R_7$

$$V_0 = \left(1 + \frac{2R_2}{R_1} \right) \frac{R_4}{R_3} (V_2 - V_1)$$

Illustration is:
 $V_0 = 101(V_2 - V_1)$

Figure 41. Balanced Input Mic Amp

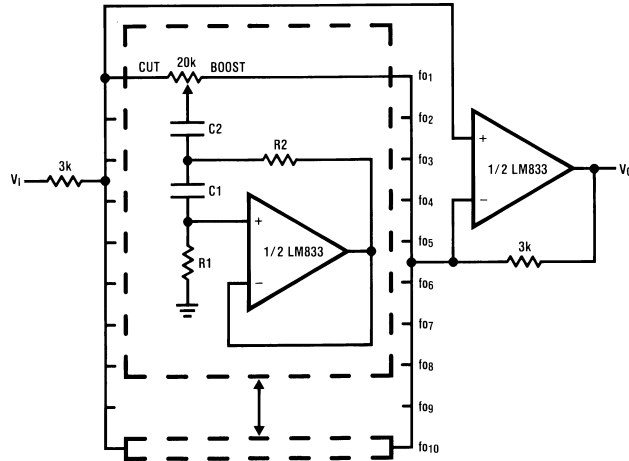

Figure 42. 10 Band Graphic Equalizer

fo (Hz)	C ₁	C ₂	R ₁	R ₂
32	0.12μF	4.7μF	75kΩ	500Ω
64	0.056μF	3.3μF	68kΩ	510Ω
125	0.033μF	1.5μF	62kΩ	510Ω
250	0.015μF	0.82μF	68kΩ	470Ω
500	8200pF	0.39μF	62kΩ	470Ω
1k	3900pF	0.22μF	68kΩ	470Ω
2k	2000pF	0.1μF	68kΩ	470Ω
4k	1100pF	0.056μF	62kΩ	470Ω
8k	510pF	0.022μF	68kΩ	510Ω
16k	330pF	0.012μF	51kΩ	510Ω

Note: At volume of change = ±12 dB Q = 1.

LM833-N MDC MWC DUAL AUDIO OPERATIONAL AMPLIFIER

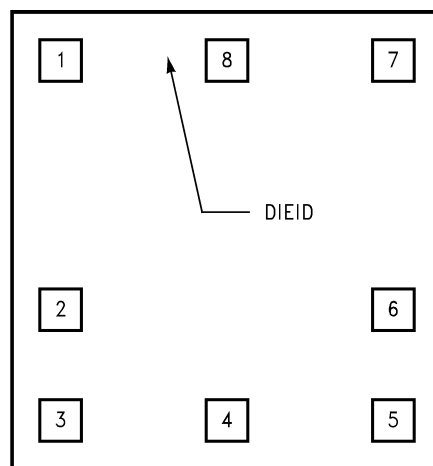

Figure 43. Die Layout (A - Step)

PACKAGING INFORMATION

Orderable Device	Status (1)	Package Type	Package Drawing	Pins	Package Qty	Eco Plan (2)	Lead/Ball Finish	MSL Peak Temp (3)	Op Temp (°C)	Top-Side Markings (4)	Samples
LM833M	ACTIVE	SOIC	D	8	95	TBD	Call TI	Call TI	-40 to 85	LM833 M	Samples
LM833M/NOPB	ACTIVE	SOIC	D	8	95	Green (RoHS & no Sb/Br)	CU SN	Level-1-260C-UNLIM	-40 to 85	LM833 M	Samples
LM833MM	ACTIVE	VSSOP	DGK	8	1000	TBD	Call TI	Call TI	-40 to 85	Z83	Samples
LM833MM/NOPB	ACTIVE	VSSOP	DGK	8	1000	Green (RoHS & no Sb/Br)	CU SN	Level-1-260C-UNLIM	-40 to 85	Z83	Samples
LM833MMX/NOPB	ACTIVE	VSSOP	DGK	8	3500	Green (RoHS & no Sb/Br)	CU SN	Level-1-260C-UNLIM	-40 to 85	Z83	Samples
LM833MX	ACTIVE	SOIC	D	8	2500	TBD	Call TI	Call TI	-40 to 85	LM833 M	Samples
LM833MX/NOPB	ACTIVE	SOIC	D	8	2500	Green (RoHS & no Sb/Br)	CU SN	Level-1-260C-UNLIM	-40 to 85	LM833 M	Samples
LM833N	ACTIVE	PDIP	P	8	40	TBD	Call TI	Call TI	-40 to 85	LM 833N	Samples
LM833N/NOPB	ACTIVE	PDIP	P	8	40	Green (RoHS & no Sb/Br)	Call TI	Level-1-NA-UNLIM	-40 to 85	LM 833N	Samples

(1) The marketing status values are defined as follows:

ACTIVE: Product device recommended for new designs.

LIFEBUY: TI has announced that the device will be discontinued, and a lifetime-buy period is in effect.

NRND: Not recommended for new designs. Device is in production to support existing customers, but TI does not recommend using this part in a new design.

PREVIEW: Device has been announced but is not in production. Samples may or may not be available.

OBSOLETE: TI has discontinued the production of the device.

(2) Eco Plan - The planned eco-friendly classification: Pb-Free (RoHS), Pb-Free (RoHS Exempt), or Green (RoHS & no Sb/Br) - please check <http://www.ti.com/productcontent> for the latest availability information and additional product content details.

TBD: The Pb-Free/Green conversion plan has not been defined.

Pb-Free (RoHS): TI's terms "Lead-Free" or "Pb-Free" mean semiconductor products that are compatible with the current RoHS requirements for all 6 substances, including the requirement that lead not exceed 0.1% by weight in homogeneous materials. Where designed to be soldered at high temperatures, TI Pb-Free products are suitable for use in specified lead-free processes.

Pb-Free (RoHS Exempt): This component has a RoHS exemption for either 1) lead-based flip-chip solder bumps used between the die and package, or 2) lead-based die adhesive used between the die and leadframe. The component is otherwise considered Pb-Free (RoHS compatible) as defined above.

Green (RoHS & no Sb/Br): TI defines "Green" to mean Pb-Free (RoHS compatible), and free of Bromine (Br) and Antimony (Sb) based flame retardants (Br or Sb do not exceed 0.1% by weight in homogeneous material)

(3) MSL, Peak Temp. -- The Moisture Sensitivity Level rating according to the JEDEC industry standard classifications, and peak solder temperature.

⁽⁴⁾ Multiple Top-Side Markings will be inside parentheses. Only one Top-Side Marking contained in parentheses and separated by a "~" will appear on a device. If a line is indented then it is a continuation of the previous line and the two combined represent the entire Top-Side Marking for that device.

Important Information and Disclaimer: The information provided on this page represents TI's knowledge and belief as of the date that it is provided. TI bases its knowledge and belief on information provided by third parties, and makes no representation or warranty as to the accuracy of such information. Efforts are underway to better integrate information from third parties. TI has taken and continues to take reasonable steps to provide representative and accurate information but may not have conducted destructive testing or chemical analysis on incoming materials and chemicals. TI and TI suppliers consider certain information to be proprietary, and thus CAS numbers and other limited information may not be available for release.

In no event shall TI's liability arising out of such information exceed the total purchase price of the TI part(s) at issue in this document sold by TI to Customer on an annual basis.

TAPE AND REEL INFORMATION

QUADRANT ASSIGNMENTS FOR PIN 1 ORIENTATION IN TAPE

*All dimensions are nominal

Device	Package Type	Package Drawing	Pins	SPQ	Reel Diameter (mm)	Reel Width W1 (mm)	A0 (mm)	B0 (mm)	K0 (mm)	P1 (mm)	W (mm)	Pin1 Quadrant
LM833MM	VSSOP	DGK	8	1000	178.0	12.4	5.3	3.4	1.4	8.0	12.0	Q1
LM833MM/NOPB	VSSOP	DGK	8	1000	178.0	12.4	5.3	3.4	1.4	8.0	12.0	Q1
LM833MMX/NOPB	VSSOP	DGK	8	3500	330.0	12.4	5.3	3.4	1.4	8.0	12.0	Q1
LM833MX	SOIC	D	8	2500	330.0	12.4	6.5	5.4	2.0	8.0	12.0	Q1
LM833MX/NOPB	SOIC	D	8	2500	330.0	12.4	6.5	5.4	2.0	8.0	12.0	Q1

TAPE AND REEL BOX DIMENSIONS

*All dimensions are nominal

Device	Package Type	Package Drawing	Pins	SPQ	Length (mm)	Width (mm)	Height (mm)
LM833MM	VSSOP	DGK	8	1000	210.0	185.0	35.0
LM833MM/NOPB	VSSOP	DGK	8	1000	210.0	185.0	35.0
LM833MMX/NOPB	VSSOP	DGK	8	3500	367.0	367.0	35.0
LM833MX	SOIC	D	8	2500	367.0	367.0	35.0
LM833MX/NOPB	SOIC	D	8	2500	367.0	367.0	35.0

P (R-PDIP-T8)

PLASTIC DUAL-IN-LINE PACKAGE

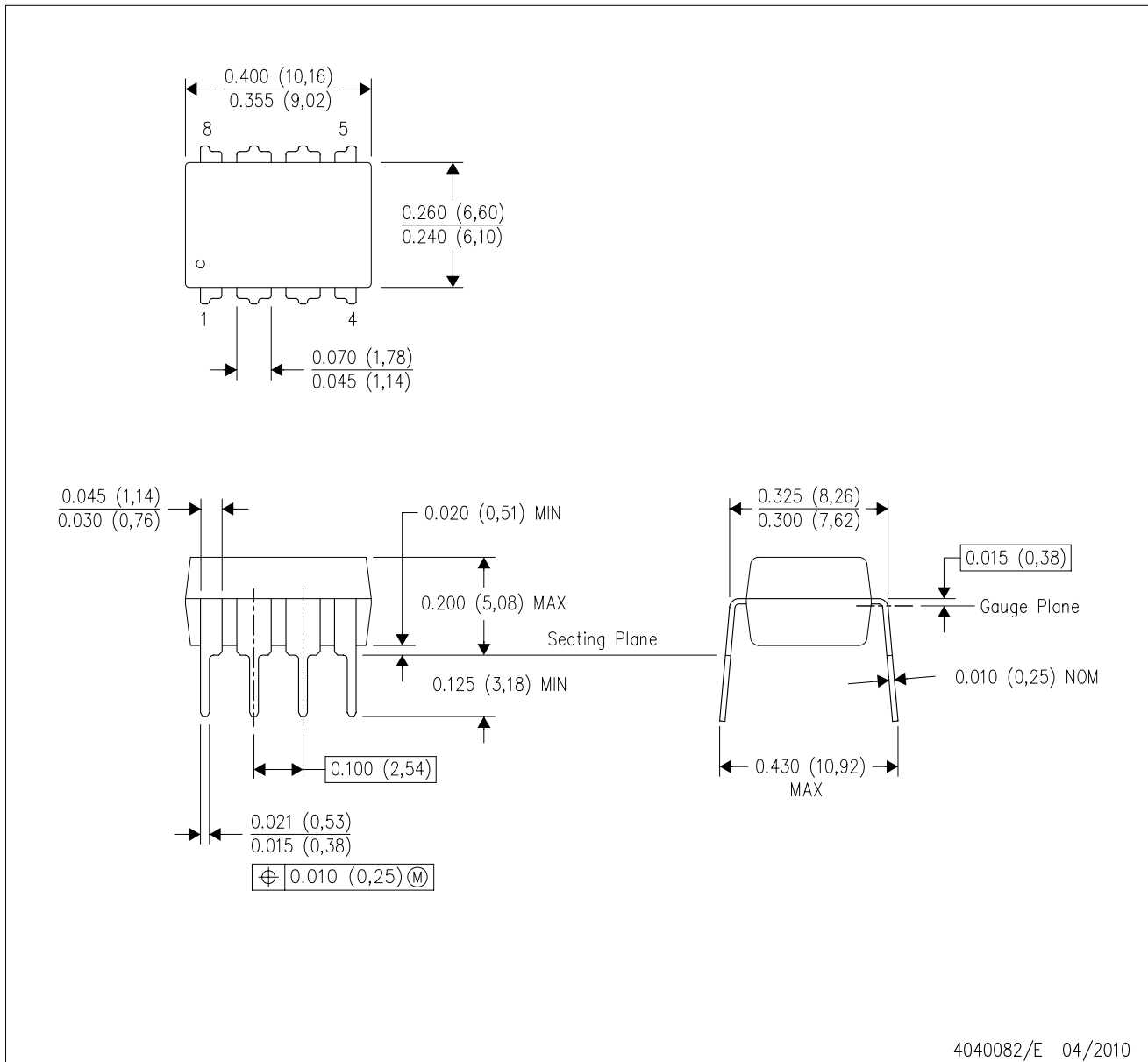

4040082/E 04/2010

- NOTES:
- A. All linear dimensions are in inches (millimeters).
 - B. This drawing is subject to change without notice.
 - C. Falls within JEDEC MS-001 variation BA.

DGK (S-PDSO-G8)

PLASTIC SMALL-OUTLINE PACKAGE

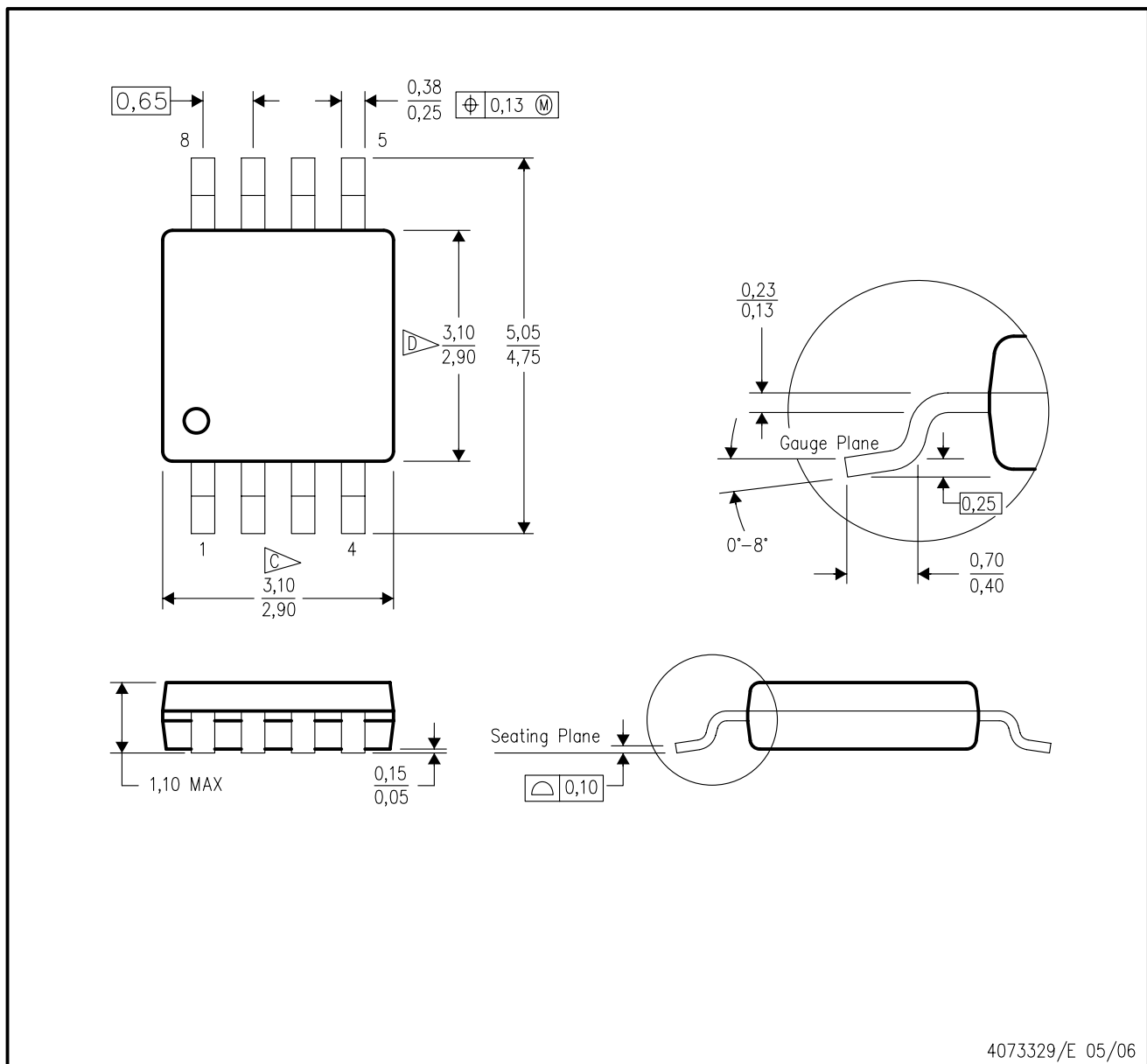

- NOTES:
- A. All linear dimensions are in millimeters.
 - B. This drawing is subject to change without notice.
 - C. Body length does not include mold flash, protrusions, or gate burrs. Mold flash, protrusions, or gate burrs shall not exceed 0.15 per end.
 - D. Body width does not include interlead flash. Interlead flash shall not exceed 0.50 per side.
 - E. Falls within JEDEC MO-187 variation AA, except interlead flash.

D (R-PDSO-G8)

PLASTIC SMALL OUTLINE



NOTES: A. All linear dimensions are in inches (millimeters).
 B. This drawing is subject to change without notice.
 C. Body length does not include mold flash, protrusions, or gate burrs. Mold flash, protrusions, or gate burrs shall not exceed 0.006 (0,15) each side.
 D. Body width does not include interlead flash. Interlead flash shall not exceed 0.017 (0,43) each side.
 E. Reference JEDEC MS-012 variation AA.

IMPORTANT NOTICE

Texas Instruments Incorporated and its subsidiaries (TI) reserve the right to make corrections, enhancements, improvements and other changes to its semiconductor products and services per JESD46, latest issue, and to discontinue any product or service per JESD48, latest issue. Buyers should obtain the latest relevant information before placing orders and should verify that such information is current and complete. All semiconductor products (also referred to herein as "components") are sold subject to TI's terms and conditions of sale supplied at the time of order acknowledgment.

TI warrants performance of its components to the specifications applicable at the time of sale, in accordance with the warranty in TI's terms and conditions of sale of semiconductor products. Testing and other quality control techniques are used to the extent TI deems necessary to support this warranty. Except where mandated by applicable law, testing of all parameters of each component is not necessarily performed.

TI assumes no liability for applications assistance or the design of Buyers' products. Buyers are responsible for their products and applications using TI components. To minimize the risks associated with Buyers' products and applications, Buyers should provide adequate design and operating safeguards.

TI does not warrant or represent that any license, either express or implied, is granted under any patent right, copyright, mask work right, or other intellectual property right relating to any combination, machine, or process in which TI components or services are used. Information published by TI regarding third-party products or services does not constitute a license to use such products or services or a warranty or endorsement thereof. Use of such information may require a license from a third party under the patents or other intellectual property of the third party, or a license from TI under the patents or other intellectual property of TI.

Reproduction of significant portions of TI information in TI data books or data sheets is permissible only if reproduction is without alteration and is accompanied by all associated warranties, conditions, limitations, and notices. TI is not responsible or liable for such altered documentation. Information of third parties may be subject to additional restrictions.

Resale of TI components or services with statements different from or beyond the parameters stated by TI for that component or service voids all express and any implied warranties for the associated TI component or service and is an unfair and deceptive business practice. TI is not responsible or liable for any such statements.

Buyer acknowledges and agrees that it is solely responsible for compliance with all legal, regulatory and safety-related requirements concerning its products, and any use of TI components in its applications, notwithstanding any applications-related information or support that may be provided by TI. Buyer represents and agrees that it has all the necessary expertise to create and implement safeguards which anticipate dangerous consequences of failures, monitor failures and their consequences, lessen the likelihood of failures that might cause harm and take appropriate remedial actions. Buyer will fully indemnify TI and its representatives against any damages arising out of the use of any TI components in safety-critical applications.

In some cases, TI components may be promoted specifically to facilitate safety-related applications. With such components, TI's goal is to help enable customers to design and create their own end-product solutions that meet applicable functional safety standards and requirements. Nonetheless, such components are subject to these terms.

No TI components are authorized for use in FDA Class III (or similar life-critical medical equipment) unless authorized officers of the parties have executed a special agreement specifically governing such use.

Only those TI components which TI has specifically designated as military grade or "enhanced plastic" are designed and intended for use in military/aerospace applications or environments. Buyer acknowledges and agrees that any military or aerospace use of TI components which have **not** been so designated is solely at the Buyer's risk, and that Buyer is solely responsible for compliance with all legal and regulatory requirements in connection with such use.

TI has specifically designated certain components as meeting ISO/TS16949 requirements, mainly for automotive use. In any case of use of non-designated products, TI will not be responsible for any failure to meet ISO/TS16949.

Products

Audio	www.ti.com/audio
Amplifiers	amplifier.ti.com
Data Converters	dataconverter.ti.com
DLP® Products	www.dlp.com
DSP	dsp.ti.com
Clocks and Timers	www.ti.com/clocks
Interface	interface.ti.com
Logic	logic.ti.com
Power Mgmt	power.ti.com
Microcontrollers	microcontroller.ti.com
RFID	www.ti-rfid.com
OMAP Applications Processors	www.ti.com/omap
Wireless Connectivity	www.ti.com/wirelessconnectivity

Applications

Automotive and Transportation	www.ti.com/automotive
Communications and Telecom	www.ti.com/communications
Computers and Peripherals	www.ti.com/computers
Consumer Electronics	www.ti.com/consumer-apps
Energy and Lighting	www.ti.com/energy
Industrial	www.ti.com/industrial
Medical	www.ti.com/medical
Security	www.ti.com/security
Space, Avionics and Defense	www.ti.com/space-avionics-defense
Video and Imaging	www.ti.com/video

TI E2E Community

e2e.ti.com