

## LP2951JAN Series of Adjustable Micropower Voltage Regulators

 Check for Samples: [LP2951JAN](#)

### FEATURES

- High Accuracy Output Voltage
- Ensured 100mA Output Current
- Extremely Low Quiescent Current
- Low Dropout Voltage
- Extremely Tight Load and Line Regulation
- Very Low Temperature Coefficient
- Use as Regulator or Reference
- Needs Minimum Capacitance for Stability
- Current and Thermal Limiting
- Stable with Low-ESR Output Capacitors (10mΩ to 6Ω)
- Error Flag Warns of Output Dropout
- Logic-Controlled Electronic Shutdown
- Output Programmable from 1.24 to 29V

### DESCRIPTION

The LP2951 is a micropower voltage regulator with very low quiescent current (75μA typ.) and very low dropout voltage (typ. 40mV at light loads and 380mV at 100mA). It is ideally suited for use in battery-powered systems. Furthermore, the quiescent current increases only slightly in dropout, prolonging battery life.

An additional feature is an error flag output which warns of a low output voltage, often due to falling batteries on the input. It may be used for a power-on reset. A second feature is the logic-compatible shutdown input which enables the regulator to be switched on and off. Also, the part may be pin-strapped for a 5V, 3V, or 3.3V output (depending on the version), or programmed from 1.24V to 29V with an external pair of resistors.

Careful design of the LP2951 has minimized all contributions to the error budget. This includes a tight initial tolerance (0.5% typ.), extremely good load and line regulation (0.05% typ.) and a very low output voltage temperature coefficient, making the part useful as a low-power voltage reference.

### Connection Diagram

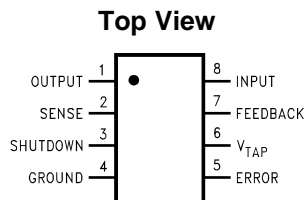

**Figure 1. CDIP Package**  
See Package Number NAB0008A



Please be aware that an important notice concerning availability, standard warranty, and use in critical applications of Texas Instruments semiconductor products and disclaimers thereto appears at the end of this data sheet.

All trademarks are the property of their respective owners.

**Block Diagram**

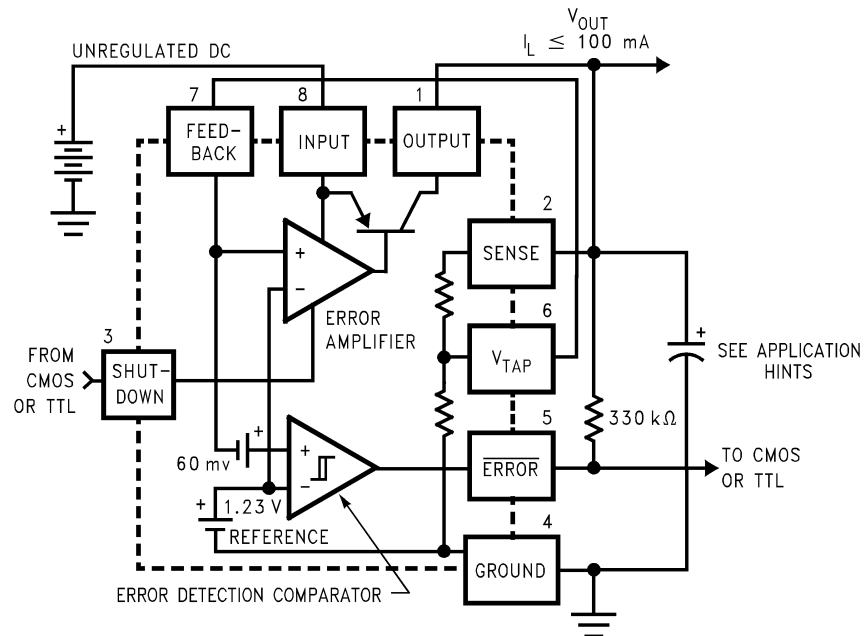

Schematic Diagram

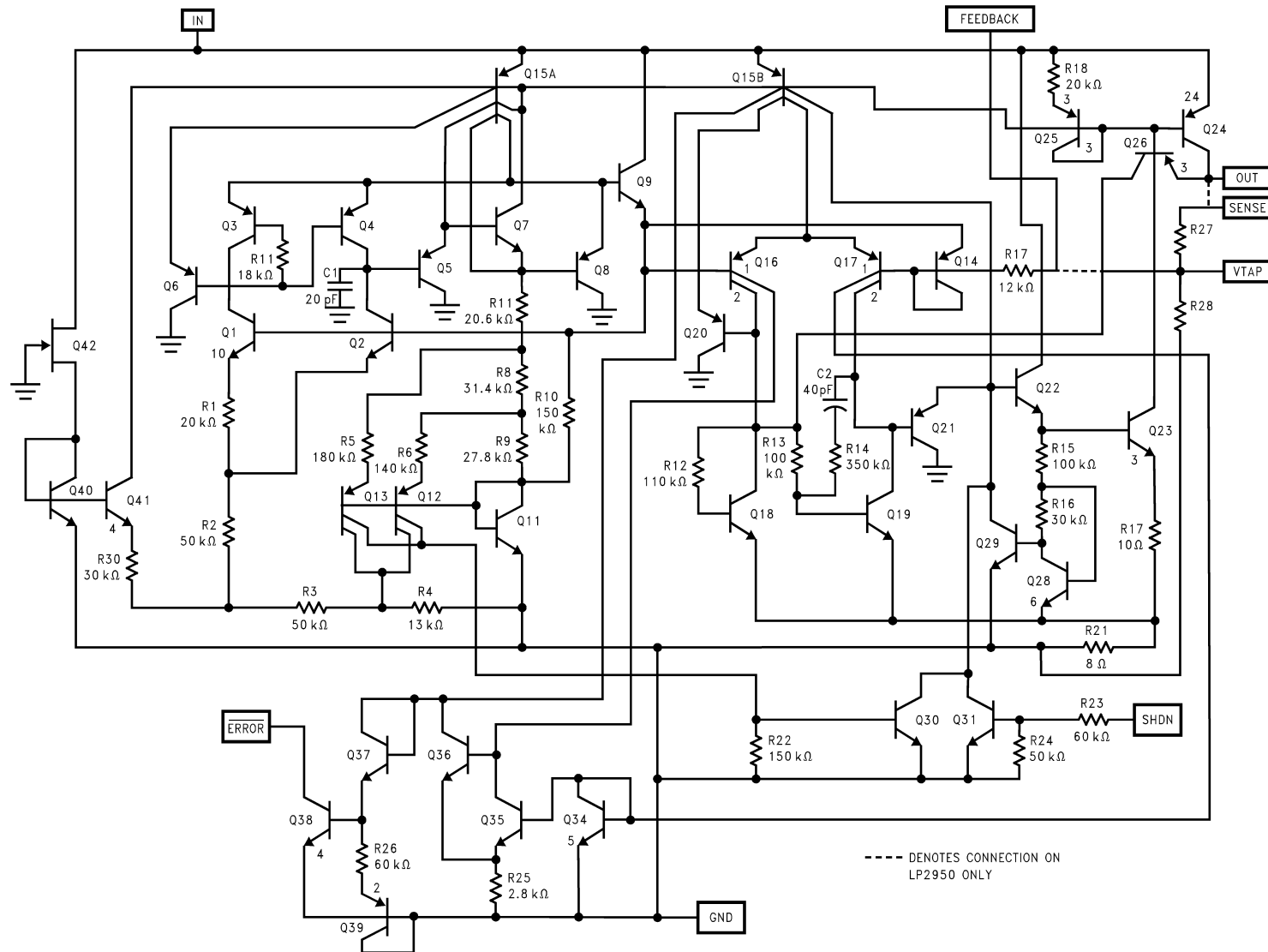



These devices have limited built-in ESD protection. The leads should be shorted together or the device placed in conductive foam during storage or handling to prevent electrostatic damage to the MOS gates.

**Absolute Maximum Ratings<sup>(1)</sup>**

Input Supply Voltage		-0.3 to +30V	
Shutdown Input Voltage <sup>(2)</sup>		-0.3 to +30V	
Error Comparator Output Voltage <sup>(2)</sup>		-0.3 to +30V	
Feedback Input Voltage <sup>(2)(3)</sup>		-1.5 to +30V	
Power Dissipation <sup>(4)</sup>	CDIP	1.0 W at 25°C	
Junction Temperature (T <sub>J</sub> )		+160°C	
Ambient Storage Temperature Range		-65°C ≤ T <sub>A</sub> ≤ +150°C	
Ambient Operating Temperature Range		-55°C ≤ T <sub>A</sub> ≤ +125°C	
Lead Temperature (Soldering 10 Seconds)		260°C	
Thermal Resistance	θ <sub>JA</sub>	CDIP (Still Air at 0.5W)	131°C/W
		CDIP (500LF/Min Air flow at 0.5W)	75°C/W
	θ <sub>JC</sub>	CDIP	21°C/W
ESD Rating <sup>(5)</sup>		500V	

- (1) Absolute Maximum Ratings indicate limits beyond which damage to the device may occur. Operating Ratings indicate conditions for which the device is functional, but do not ensure specific performance limits. For ensured specifications and test conditions, see the Electrical Characteristics. The specified specifications apply only for the test conditions listed. Some performance characteristics may degrade when the device is not operated under the listed test conditions.
- (2) May exceed input supply voltage.
- (3) When used in dual-supply systems where the output terminal sees loads returned to a negative supply, the output voltage should be diode-clamped to ground.
- (4) The maximum power dissipation must be derated at elevated temperatures and is dictated by T<sub>Jmax</sub> (maximum junction temperature), θ<sub>JA</sub> (package junction to ambient thermal resistance), and T<sub>A</sub> (ambient temperature). The maximum allowable power dissipation at any temperature is P<sub>Dmax</sub> = (T<sub>Jmax</sub> - T<sub>A</sub>)/θ<sub>JA</sub> or the number given in the Absolute Maximum Ratings, whichever is lower.
- (5) Human body model, 1.5 kΩ in series with 100 pF.

**Table 1. Quality Conformance Inspection Mil-Std-883, Method 5005 - Group A**

SUBGROUP	DESCRIPTION	TEMP (°C)
1	Static tests at	+25
2	Static tests at	+125
3	Static tests at	-55
4	Dynamic tests at	+25
5	Dynamic tests at	+125
6	Dynamic tests at	-55
7	Functional tests at	+25
8A	Functional tests at	+125
8B	Functional tests at	-55
9	Switching tests at	+25
10	Switching tests at	+125
11	Switching tests at	-55
12	Settling time at	+25
13	Settling time at	+125
14	Settling time at	-55

**JL2951 Electrical Characteristics DC Parameters**

 The following conditions apply, unless otherwise specified.  $V_{IN} = 6V$ ,  $I_L = -100\mu A$ ,  $C_L = 3.3\mu F$ ,  $V_O = 5V$  (Nominal),  $V_{SD} = 0.6V$ 

PARAMETER		TEST CONDITIONS	NOTES	MIN	MAX	UNIT	SUBGROUPS
$V_O$	Output Voltage			4.975	5.025	V	1
				4.94	5.06	V	2, 3
$V_{O\text{ Line}}$	Line Regulation	$6V \leq V_{IN} \leq 30V$ , $I_L = -1mA$		-5.0	5.0	mV	1
				-25	25	mV	2, 3
$V_{O\text{ Load}}$	Load Regulation	$-100\mu A \leq I_L \leq -100mA$		-5.0	5.0	mV	1
				-25	25	mV	2, 3
$V_D$	Dropout Voltage	$I_L = -100mA$			450	mV	1
					600	mV	2, 3
					80	mV	1
$I_G$	Ground Current	$I_L = -100mA$ ,			150	mV	2, 3
					12	mA	1
					14	mA	2, 3
		$V_O = 15V$ , $V_{IN} = 30V$			120	$\mu A$	1
					140	$\mu A$	2, 3
					120	$\mu A$	1
$V_{IN} = 30V$ , $V_O = 15V$			140	$\mu A$	2, 3		
			15	mA	1		
$I_{G\text{ Diff}}$	Ground Current Change	$6V \leq V_{IN} \leq 30V$		-30	30	$\mu A$	1
				-50	50	$\mu A$	2, 3
$I_{GDO}$	Dropout Ground Current	$V_{IN} = 4.5V$			170	$\mu A$	1
					200	$\mu A$	2, 3
$V_{Th\text{ L}}$	Error Comparator Lower Threshold Voltage			0.0	0.8	mV	1, 2, 3
$V_{Th\text{ U}}$	Error Comparator Upper Threshold Voltage			2.0	30	mV	1, 2, 3
$\theta_R$	Thermal Regulation	$V_{IN} = 30V$ , $I_L = -50mA$ , $2ms \leq T \leq 10ms$		-12.5	12.5	mV	1
$I_{SC}$	Current Limit	$V_O = 0V$			200	mA	1
					220	mA	2, 3
$I_{GSC}$	Ground Current At Current Limit	$V_O = 0V$			20	mA	1
					25	mA	2, 3
$V_{Ref}$	Reference Voltage			1.22	1.25	V	1
				1.20	1.26	V	2, 3
$V_{R\text{ Line}}$	Reference Voltage Line Regulation	$2.3V \leq V_{IN} \leq 30V$		-1.9	1.9	mV	1
				-10	10	mV	2, 3
$V_{R\text{ Load}}$	Reference Voltage Output Regulation	$1.2V \leq V_O \leq 29V$ , $V_{IN} = 30V$		-1.2	1.2	mV	1
				-5.0	5.0	mV	2, 3
$I_{FB}$	Feedback Pin Bias Current				40	nA	1
					60	nA	2, 3
$I_{OH}$	Error Comparator Output Leakage Current	$V_O = 30V$			1.0	$\mu A$	1
					2.0	$\mu A$	2, 3
$V_{OL}$	Error Comparator Output Low Voltage	$V_{IN} = 4.5V$ , $V_{SD} = 2V$			250	mV	1
					400	mV	2, 3

### JL2951 Electrical Characteristics DC Parameters (continued)

The following conditions apply, unless otherwise specified.  $V_{IN} = 6V$ ,  $I_L = -100\mu A$ ,  $C_L = 3.3\mu F$ ,  $V_O = 5V$  (Nominal),  $V_{SD} = 0.6V$

PARAMETER		TEST CONDITIONS	NOTES	MIN	MAX	UNIT	SUBGROUPS
$I_{SD}$	Shutdown Pin Input Current	$V_{SD} = 2.4V$			50	$\mu A$	1
					100	$\mu A$	2, 3
		$V_{SD} = 30V$			600	$\mu A$	1
					750	$\mu A$	2, 3
$V_{SDL}$	Shutdown Input Logic Voltage	Low	See <sup>(1)</sup>		0.6	V	1, 2, 3
$V_{SDH}$	Shutdown Input Logic Voltage	High	See <sup>(1)</sup>	2.0		V	1, 2, 3
$I_{LKG}$	Regular Output Bias Current In Shutdown	$V_{SD} = 2V$ , $V_{IN} = 30V$ , $I_L = 0mA$		-10	10	$\mu A$	1
				-20	20	$\mu A$	2, 3

(1) Parameter tested go-no-go only.

### JL2951 Electrical Characteristics AC Parameters

The following conditions apply, unless otherwise specified.  $V_{IN} = 6V$ ,  $C_L = 3.3\mu F$ ,  $V_{SD} = 0.6V$

PARAMETER		TEST CONDITIONS	NOTES	MIN	MAX	UNIT	SUBGROUP
RR	Ripple Rejection	$f = 120Hz$ , $V_{IN} = 0.1V_{RMS}$		50		dB	4
$V_{Noise}$	Output Noise	$C_L = 1\mu F$			600	$\mu V_{RMS}$	7
		$C_L = 3.3\mu F$			250	$\mu V_{RMS}$	7

Typical Performance Characteristics

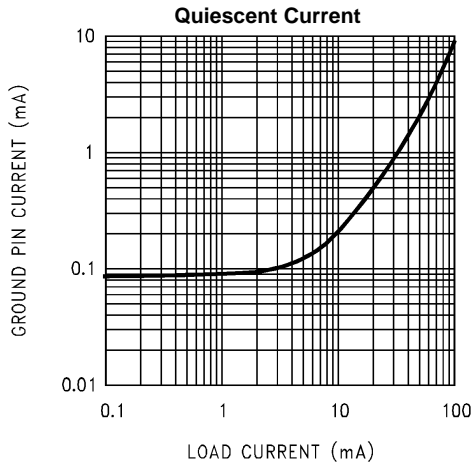

Figure 2.

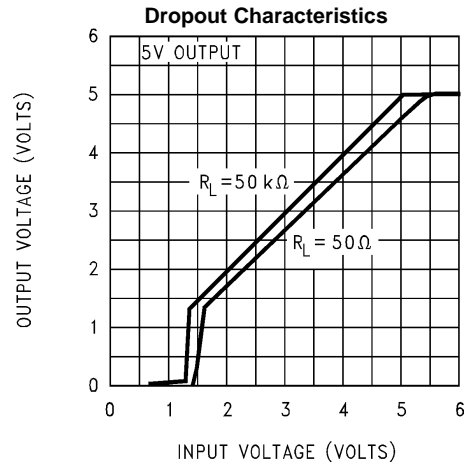

Figure 3.

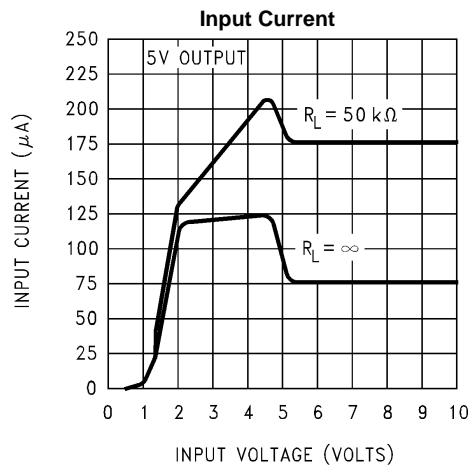

Figure 4.

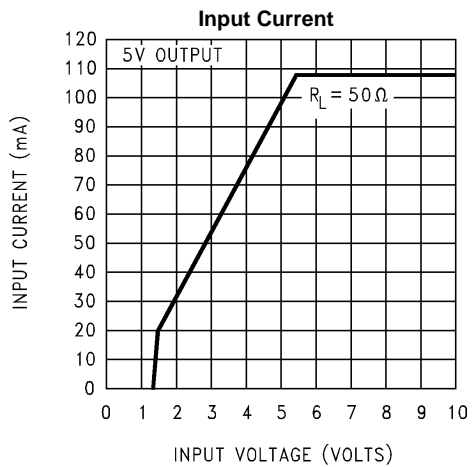

Figure 5.

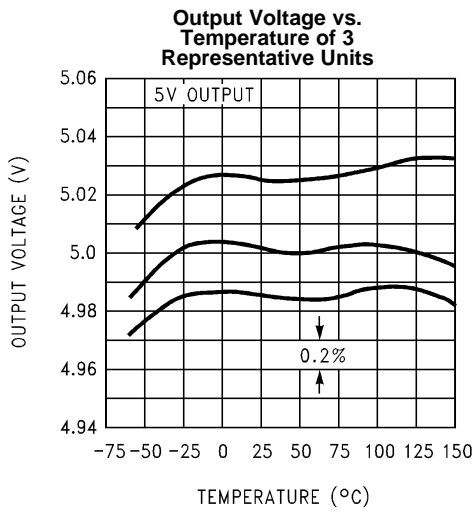

Figure 6.

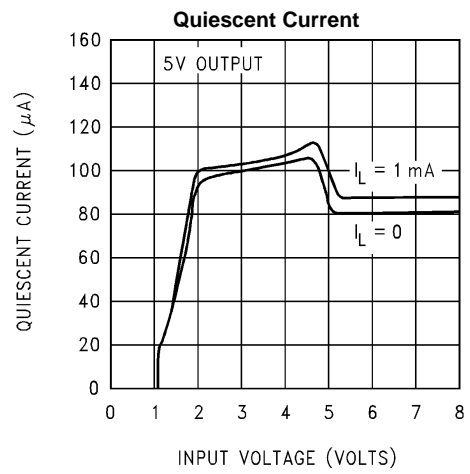

Figure 7.

**Typical Performance Characteristics (continued)**

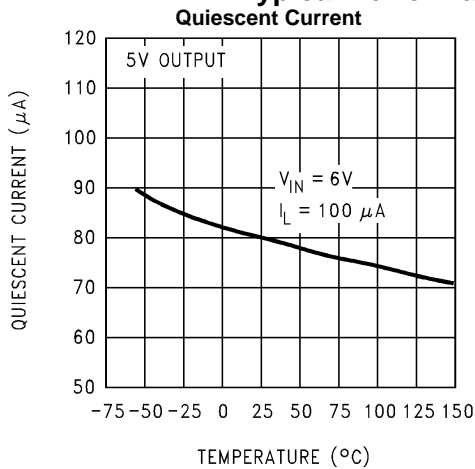

Figure 8.

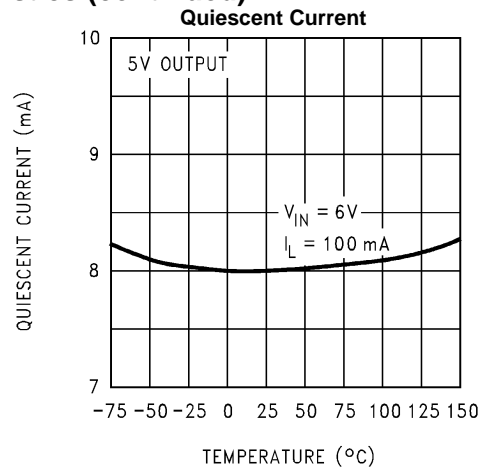

Figure 9.

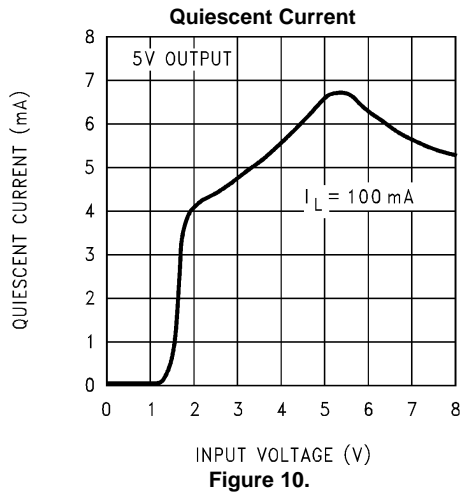

Figure 10.

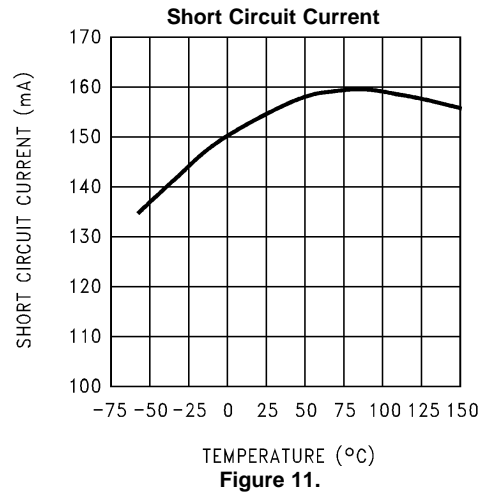

Figure 11.

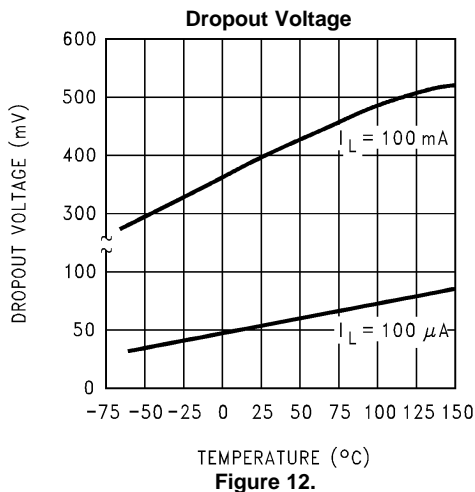

Figure 12.

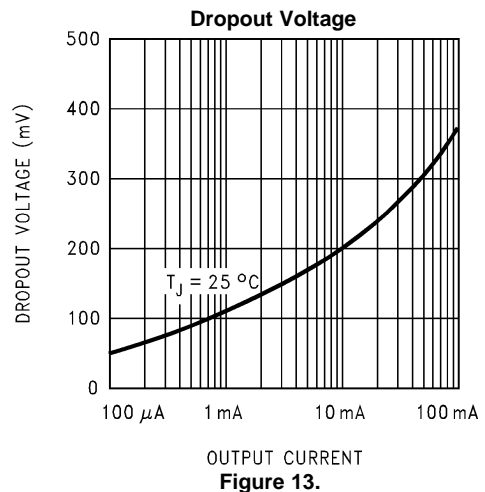

Figure 13.

Typical Performance Characteristics (continued)

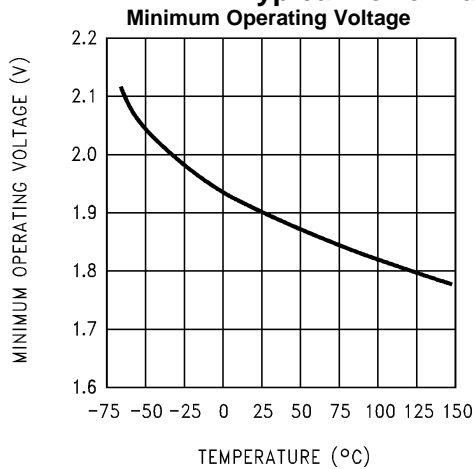

Figure 14.

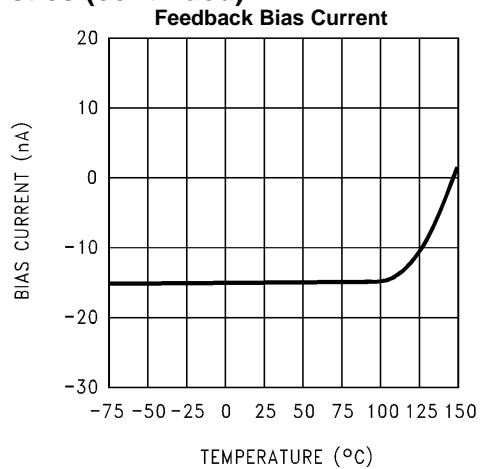

Figure 15.

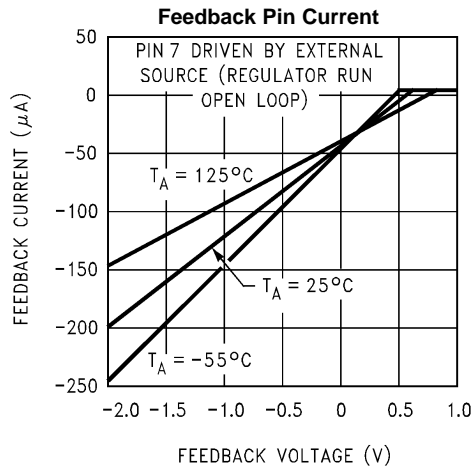

Figure 16.

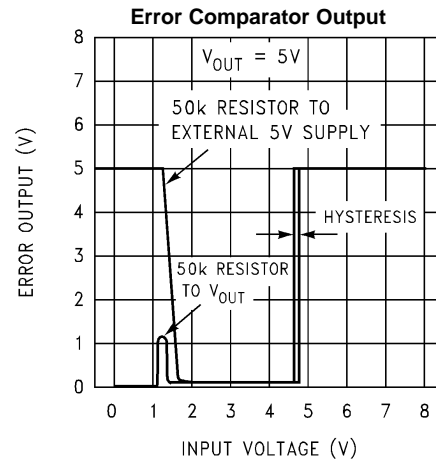

Figure 17.

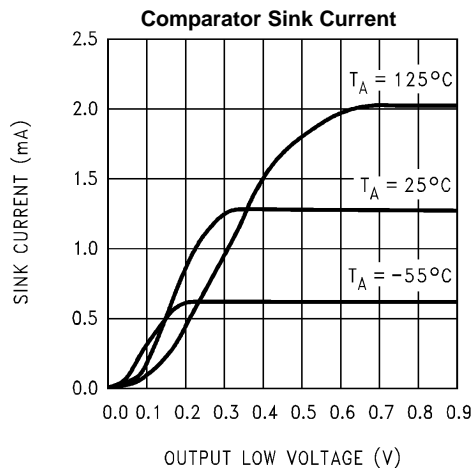

Figure 18.

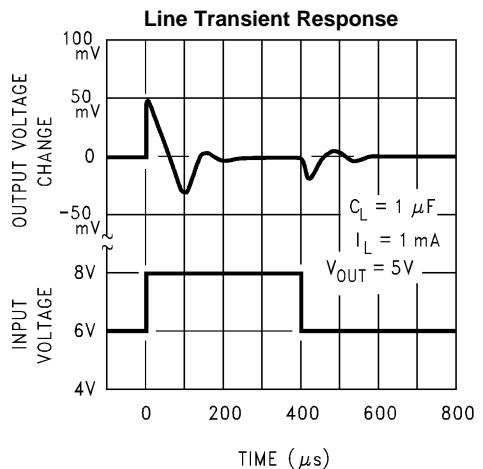

Figure 19.

**Typical Performance Characteristics (continued)**

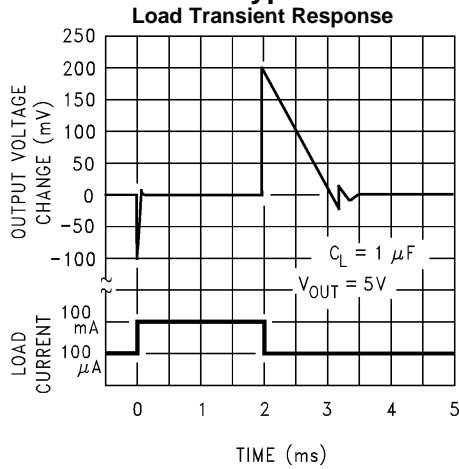

Figure 20.

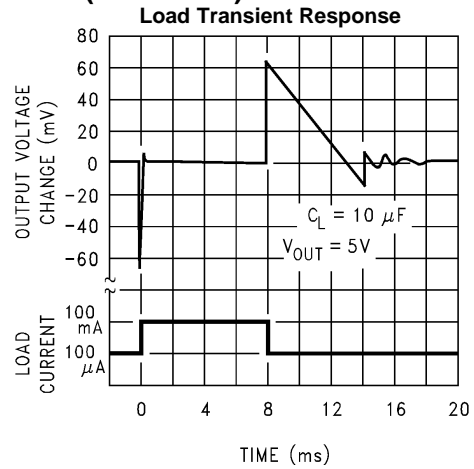

Figure 21.

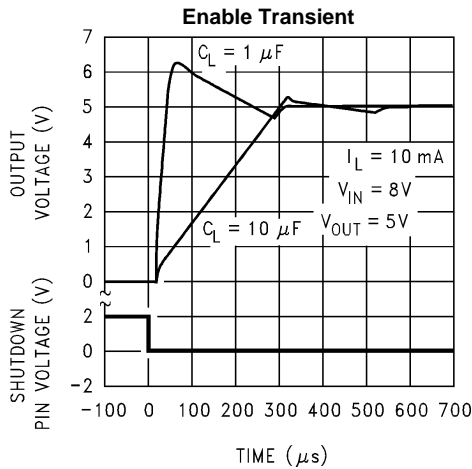

Figure 22.

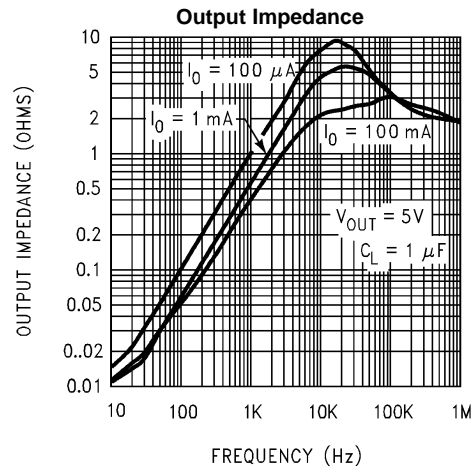

Figure 23.

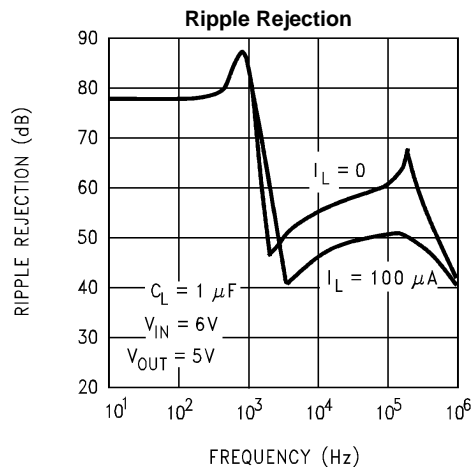

Figure 24.

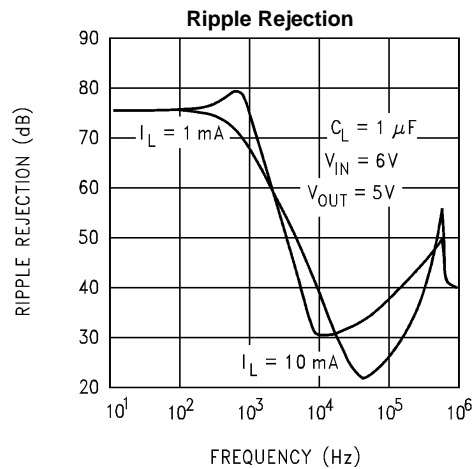

Figure 25.

Typical Performance Characteristics (continued)

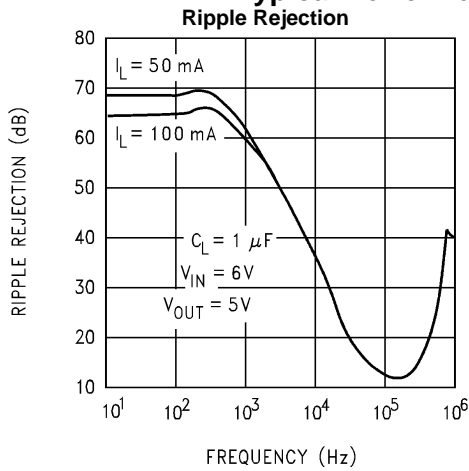

Figure 26.

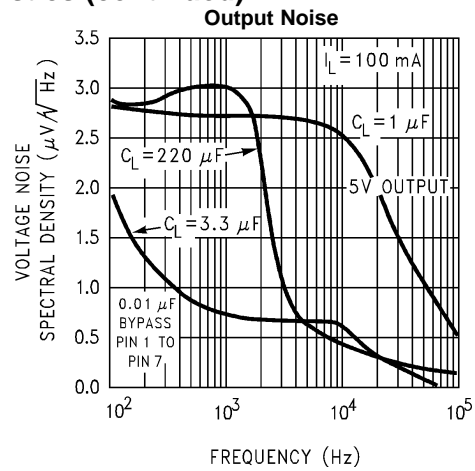

Figure 27.

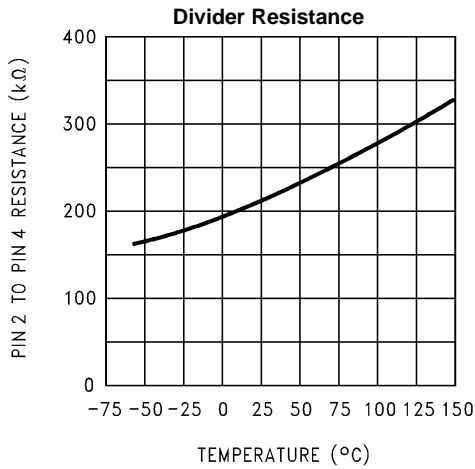

Figure 28.

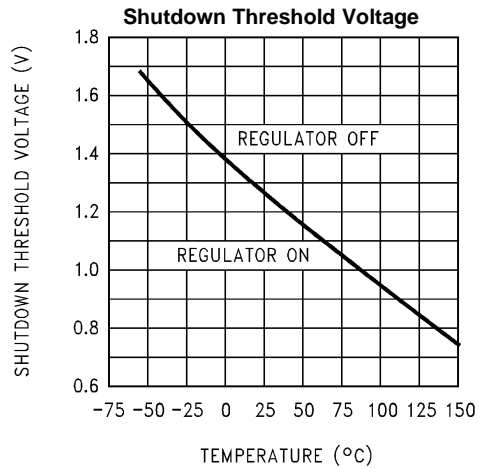

Figure 29.

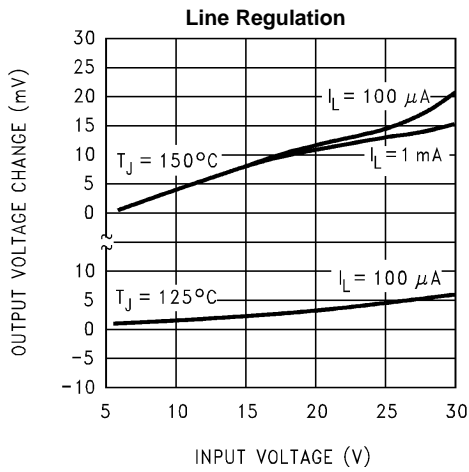

Figure 30.

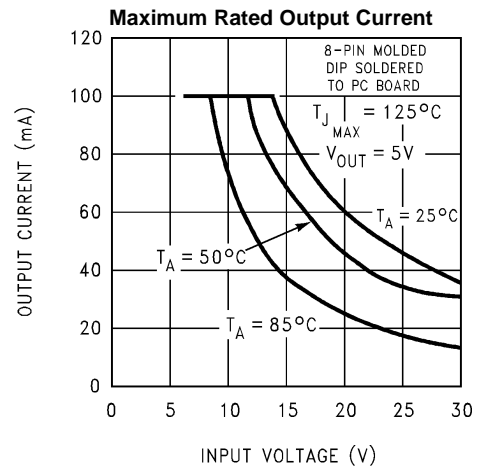

Figure 31.

**Typical Performance Characteristics (continued)**

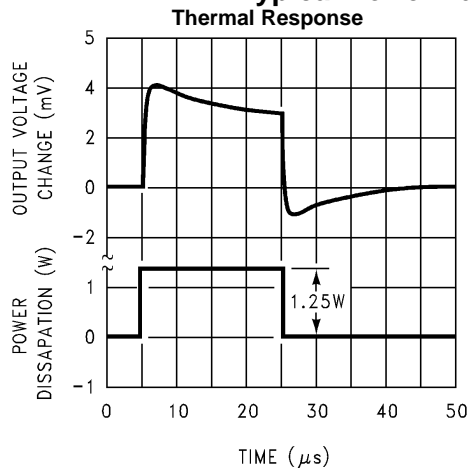

Figure 32.

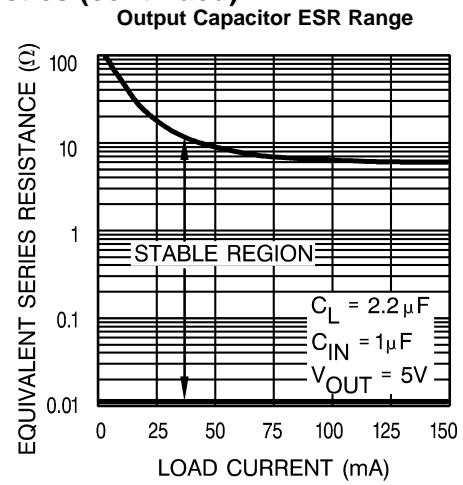

Figure 33.

## APPLICATION HINTS

### External Capacitors

A 1.0 $\mu$ F (or greater) capacitor is required between the output and ground for stability at output voltages of 5V or more. At lower output voltages, more capacitance is required (2.2 $\mu$ F or more is recommended for 3V and 3.3V versions). Without this capacitor the part will oscillate. Most types of tantalum or aluminum electrolytics work fine here; even film types work but are not recommended for reasons of cost. Many aluminum electrolytics have electrolytes that freeze at about  $-30^{\circ}\text{C}$ , so solid tantalums are recommended for operation below  $-25^{\circ}\text{C}$ . The important parameters of the capacitor are an ESR of about 5 $\Omega$  or less and a resonant frequency above 500kHz. The value of this capacitor may be increased without limit.

Ceramic capacitors whose value is greater than 1000pF should not be connected directly from the LP2951 output to ground. Ceramic capacitors typically have ESR values in the range of 5 to 10m $\Omega$ , a value below the lower limit for stable operation (see [Figure 33](#)).

The reason for the lower ESR limit is that the loop compensation of the part relies on the ESR of the output capacitor to provide the zero that gives added phase lead. The ESR of ceramic capacitors is so low that this phase lead does not occur, significantly reducing phase margin. A ceramic output capacitor can be used if a series resistance is added (recommended value of resistance is about 0.1 $\Omega$  to 2 $\Omega$ ).

At lower values of output current, less output capacitance is required for stability. The capacitor can be reduced to 0.33 $\mu$ F for currents below 10mA or 0.1 $\mu$ F for currents below 1mA. Using the adjustable versions at voltages below 5V runs the error amplifier at lower gains so that *more* output capacitance is needed. For the worst-case situation of a 100mA load at 1.23V output (Output shorted to Feedback) a 3.3 $\mu$ F (or greater) capacitor should be used.

When setting the output voltage of the LP2951 with external resistors, a minimum load of 1 $\mu$ A is recommended.

A 1 $\mu$ F tantalum, ceramic or aluminum electrolytic capacitor should be placed from the LP2951 input to ground if there is more than 10 inches of wire between the input and the AC filter capacitor or if a battery is used as the input.

Stray capacitance to the LP2951 Feedback terminal can cause instability. This may especially be a problem when using high value external resistors to set the output voltage. Adding a 100pF capacitor between Output and Feedback and increasing the output capacitor to at least 3.3 $\mu$ F will fix this problem.

### Error Detection Comparator Output

The comparator produces a logic low output whenever the LP2951 output falls out of regulation by more than approximately 5%. This figure is the comparator's built-in offset of about 60mV divided by the 1.235 reference voltage. (Refer to the [Block Diagram](#)) This trip level remains 5% below normal regardless of the programmed output voltage of the 2951. For example, the error flag trip level is typically 4.75V for a 5V output or 11.4V for a 12V output. The out of regulation condition may be due either to low input voltage, current limiting, or thermal limiting.

[Figure 34](#) below gives a timing diagram depicting the  $\overline{\text{ERROR}}$  signal and the regulated output voltage as the LP2951 input is ramped up and down. For 5V versions, the  $\overline{\text{ERROR}}$  signal becomes valid (low) at about 1.3V input. It goes high at about 5V input (the input voltage at which  $V_{\text{OUT}} = 4.75\text{V}$ ). Because the LP2951's dropout voltage is load-dependent (see [Figure 12](#)), the **input** voltage trip point (about 5V) will vary with the load current. The **output** voltage trip point (approx. 4.75V) does not vary with load.

The error comparator has an open-collector output which requires an external pullup resistor. This resistor may be returned to the output or some other supply voltage depending on system requirements. In determining a value for this resistor, note that while the output is rated to sink 400 $\mu$ A, this sink current adds to battery drain in a low battery condition. Suggested values range from 100k $\Omega$  to 1 M $\Omega$ . The resistor is not required if this output is unused.

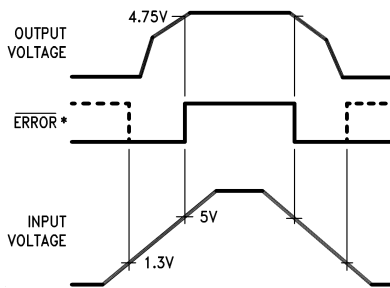

\*When  $V_{IN} \leq 1.3V$ , the error flag pin becomes a high impedance, and the error flag voltage rises to its pull-up voltage. Using  $V_{OUT}$  as the pull-up voltage (see Figure 35), rather than an external 5V source, will keep the error flag voltage under 1.2V (typ.) in this condition. The user may wish to divide down the error flag voltage using equal-value resistors (10kΩ suggested), to ensure a low-level logic signal during any fault condition, while still allowing a valid high logic level during normal operation.

Figure 34. ERROR Output Timing

### Programming The Output Voltage (LP2951)

The LP2951 may be pin-strapped for the nominal fixed output voltage using its internal voltage divider by tying the output and sense pins together, and also tying the feedback and  $V_{TAP}$  pins together. Alternatively, it may be programmed for any output voltage between its 1.235V reference and its 30V maximum rating. As seen in Figure 35, an external pair of resistors is required.

The complete equation for the output voltage is

$$V_{OUT} = V_{REF} \cdot \left( 1 + \frac{R_1}{R_2} \right) + I_{FB}R_1 \tag{1}$$

where  $V_{REF}$  is the nominal 1.235 reference voltage and  $I_{FB}$  is the feedback pin bias current, nominally  $-20nA$ . The minimum recommended load current of  $1\mu A$  forces an upper limit of 1.2 MΩ on the value of  $R_2$ , if the regulator must work with no load (a condition often found in CMOS in standby).  $I_{FB}$  will produce a 2% typical error in  $V_{OUT}$  which may be eliminated at room temperature by trimming  $R_1$ . For better accuracy, choosing  $R_2 = 100k\Omega$  reduces this error to 0.17% while increasing the resistor program current to  $12\mu A$ . Since the LP2951 typically draws  $60\mu A$  at no load with Pin 2 open-circuited, this is a small price to pay.

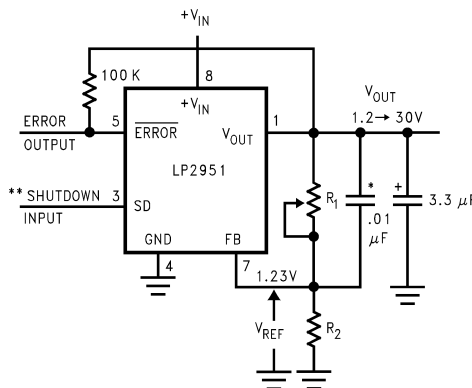

\*See Application Hints

$$V_{out} = V_{Ref} \left( 1 + \frac{R_1}{R_2} \right)$$

\*\*Drive with TTL-high to shut down. Ground or leave open if shutdown feature is not to be used.

Note: Pins 2 and 6 are left open.

Figure 35. Adjustable Regulator

## Reducing Output Noise

In reference applications it may be advantageous to reduce the AC noise present at the output. One method is to reduce the regulator bandwidth by increasing the size of the output capacitor.

Noise can be reduced fourfold by a bypass capacitor across  $R_1$ , since it reduces the high frequency gain from 4 to unity. Pick

$$C_{\text{BYPASS}} \cong \frac{1}{2\pi R_1 \cdot 200 \text{ Hz}} \quad (2)$$

or about  $0.01\mu\text{F}$ . When doing this, the output capacitor must be increased to  $3.3\mu\text{F}$  to maintain stability. These changes reduce the output noise from  $430\mu\text{V}$  to  $100\mu\text{V}$  rms for a 100kHz bandwidth at 5V output. With the bypass capacitor added, noise no longer scales with output voltage so that improvements are more dramatic at higher output voltages.

## Typical Applications

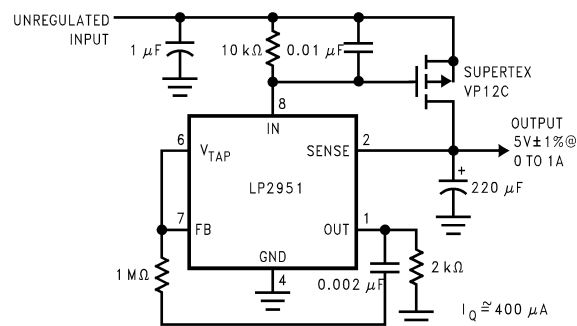

Figure 36. 1A Regulator with 1.2V Dropout

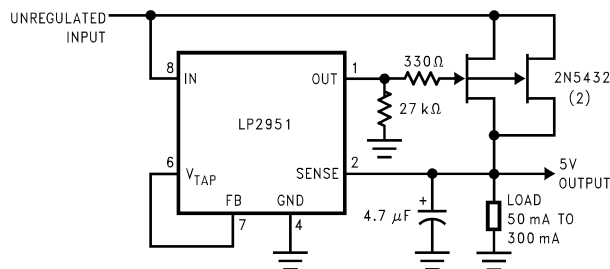
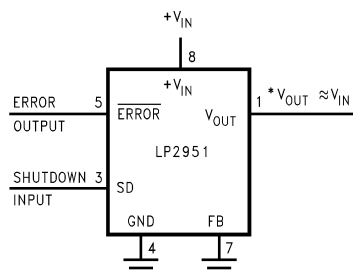

Figure 37. 300mA Regulator with 0.75V Dropout



\*Minimum input-output voltage ranges from 40mV to 400mV, depending on load current. Current limit is typically 160mA.

Figure 38. Wide Input Voltage Range Current Limiter

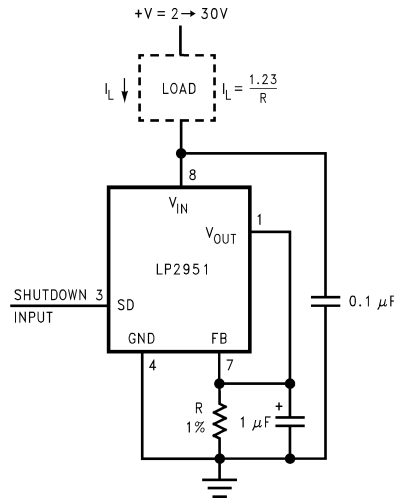
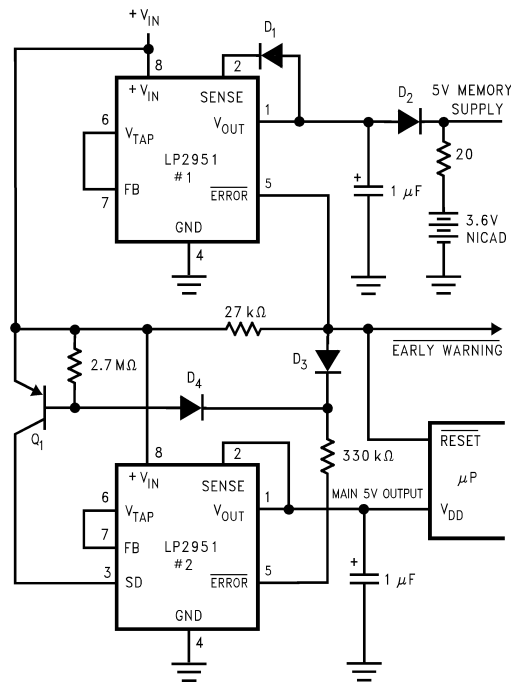

Figure 39. Low Drift Current Source



Early warning flag on low input voltage  
 Main output latches off at lower input voltages  
 Battery backup on auxiliary output  
 Operation: Reg. #1's  $V_{out}$  is programmed one diode drop above 5V. Its error flag becomes active when  $V_{in} \leq 5.7V$ .  
 When  $V_{in}$  drops below 5.3V, the error flag of Reg. #2 becomes active and via Q1 latches the main output off. When  $V_{in}$  again exceeds 5.7V Reg. #1 is back in regulation and the early warning signal rises, unlatching Reg. #2 via D3.

Figure 40. Regulator with Early Warning and Auxiliary Output

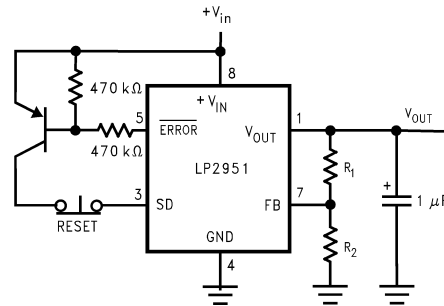
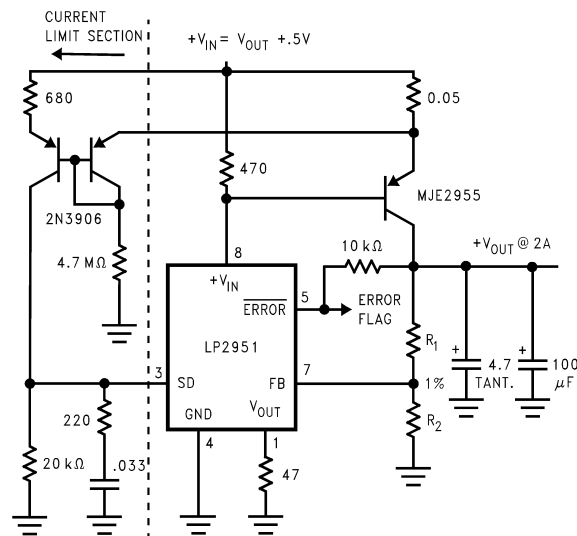

Figure 41. Latch Off When Error Flag Occurs



$$V_{out} = 1.23V \left( 1 + \frac{R_1}{R_2} \right)$$

For  $5V_{out}$ , use internal resistors. Wire pin 6 to 7, & wire pin 2 to  $+V_{out}$  Bus.

Figure 42. 2 Ampere Low Dropout Regulator

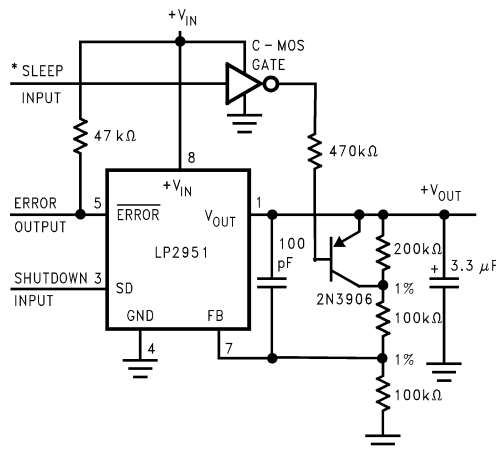

\*High input lowers  $V_{out}$  to 2.5V

Figure 43. 5V Regulator with 2.5V Sleep Function

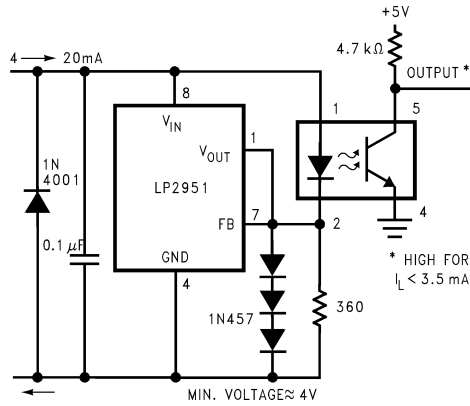
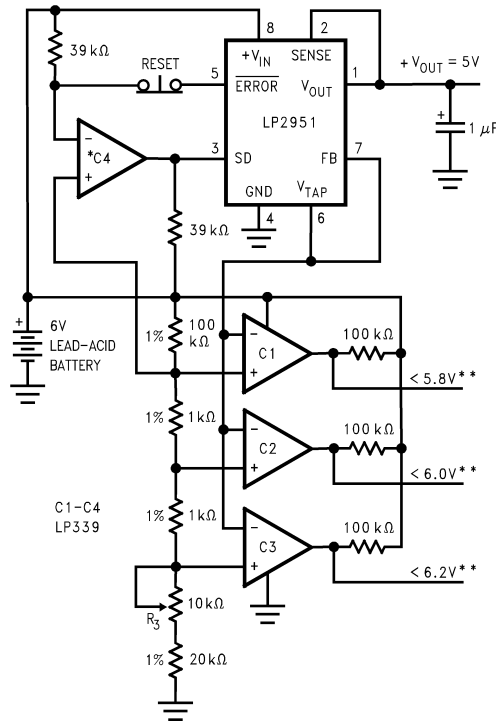

Figure 44. Open Circuit Detector for 4 to 20mA Current Loop



\*Optional Latch off when drop out occurs. Adjust R3 for C2 Switching when  $V_{in}$  is 6.0V.

\*\*Outputs go low when  $V_{in}$  drops below designated thresholds.

Figure 45. Regulator with State-of-Charge Indicator

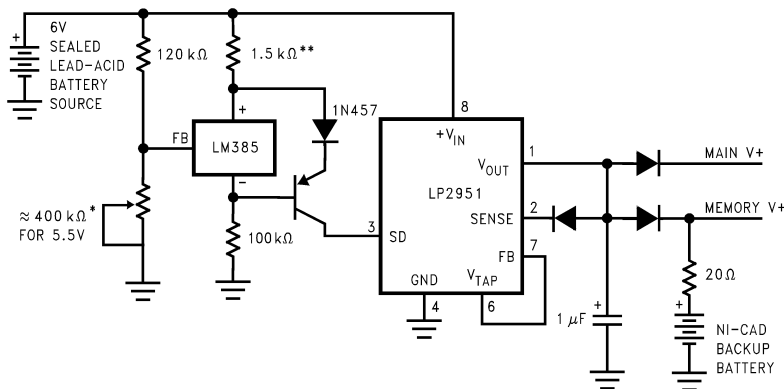

For values shown, Regulator shuts down when  $V_{in} < 5.5V$  and turns on again at 6.0V. Current drain in disconnected mode is  $\approx 150\mu A$ .

\*Sets disconnect Voltage

\*\*Sets disconnect Hysteresis

Figure 46. Low Battery Disconnect

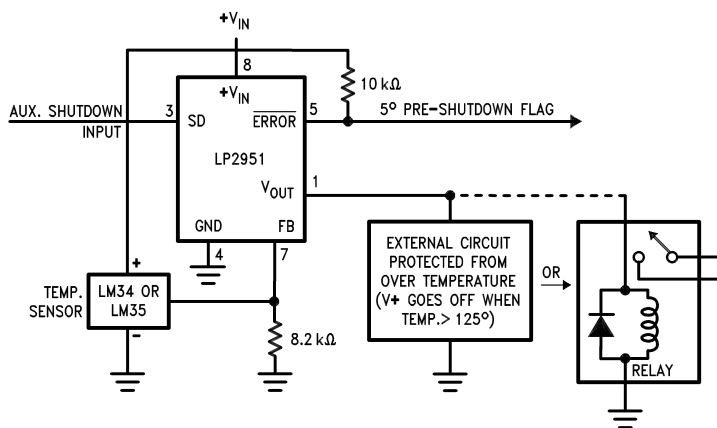

LM34 for 125°F Shutdown

LM35 for 125°C Shutdown

Figure 47. System Overtemperature Protection Circuit

**REVISION HISTORY**

Released	Revision	Section	Changes
11/30/2010	A	New Release, Corporate format	1 MDS data sheet converted into one Corp. data sheet format. MJLP2951-X Rev 1B1 will be archived.



---

**REVISION HISTORY**

<b>Changes from Original (April 2013) to Revision A</b>	<b>Page</b>
• Changed layout of National Data Sheet to TI format .....	<a href="#">15</a>

---

**PACKAGING INFORMATION**

Orderable Device	Status (1)	Package Type	Package Drawing	Pins	Package Qty	Eco Plan (2)	Lead/Ball Finish	MSL Peak Temp (3)	Op Temp (°C)	Top-Side Markings (4)	Samples
5962-3870501BPA	ACTIVE	CDIP	NAB	8	40	TBD	Call TI	Call TI	-55 to 125	JL2951BPA 5962-38705 01BPA Q ACO 01BPA Q >T	
JL2951BPA	ACTIVE	CDIP	NAB	8	40	TBD	Call TI	Call TI	-55 to 125	JL2951BPA 5962-38705 01BPA Q ACO 01BPA Q >T	

(1) The marketing status values are defined as follows:

**ACTIVE:** Product device recommended for new designs.

**LIFEBUY:** TI has announced that the device will be discontinued, and a lifetime-buy period is in effect.

**NRND:** Not recommended for new designs. Device is in production to support existing customers, but TI does not recommend using this part in a new design.

**PREVIEW:** Device has been announced but is not in production. Samples may or may not be available.

**OBSOLETE:** TI has discontinued the production of the device.

(2) Eco Plan - The planned eco-friendly classification: Pb-Free (RoHS), Pb-Free (RoHS Exempt), or Green (RoHS & no Sb/Br) - please check <http://www.ti.com/productcontent> for the latest availability information and additional product content details.

**TBD:** The Pb-Free/Green conversion plan has not been defined.

**Pb-Free (RoHS):** TI's terms "Lead-Free" or "Pb-Free" mean semiconductor products that are compatible with the current RoHS requirements for all 6 substances, including the requirement that lead not exceed 0.1% by weight in homogeneous materials. Where designed to be soldered at high temperatures, TI Pb-Free products are suitable for use in specified lead-free processes.

**Pb-Free (RoHS Exempt):** This component has a RoHS exemption for either 1) lead-based flip-chip solder bumps used between the die and package, or 2) lead-based die adhesive used between the die and leadframe. The component is otherwise considered Pb-Free (RoHS compatible) as defined above.

**Green (RoHS & no Sb/Br):** TI defines "Green" to mean Pb-Free (RoHS compatible), and free of Bromine (Br) and Antimony (Sb) based flame retardants (Br or Sb do not exceed 0.1% by weight in homogeneous material)

(3) MSL, Peak Temp. -- The Moisture Sensitivity Level rating according to the JEDEC industry standard classifications, and peak solder temperature.

(4) Multiple Top-Side Markings will be inside parentheses. Only one Top-Side Marking contained in parentheses and separated by a "~" will appear on a device. If a line is indented then it is a continuation of the previous line and the two combined represent the entire Top-Side Marking for that device.

**Important Information and Disclaimer:** The information provided on this page represents TI's knowledge and belief as of the date that it is provided. TI bases its knowledge and belief on information provided by third parties, and makes no representation or warranty as to the accuracy of such information. Efforts are underway to better integrate information from third parties. TI has taken and continues to take reasonable steps to provide representative and accurate information but may not have conducted destructive testing or chemical analysis on incoming materials and chemicals. TI and TI suppliers consider certain information to be proprietary, and thus CAS numbers and other limited information may not be available for release.

In no event shall TI's liability arising out of such information exceed the total purchase price of the TI part(s) at issue in this document sold by TI to Customer on an annual basis.

**OTHER QUALIFIED VERSIONS OF LP2951JAN, LP2951JAN-SP :**

- Military: [LP2951JAN](#)
- Space: [LP2951JAN-SP](#)

## NOTE: Qualified Version Definitions:

- Military - QML certified for Military and Defense Applications
- Space - Radiation tolerant, ceramic packaging and qualified for use in Space-based application

NAB0008A

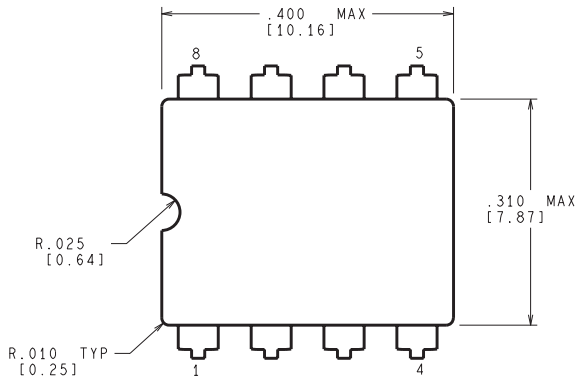

CONTROLLING DIMENSION IS INCH  
VALUES IN [ ] ARE MILLIMETERS

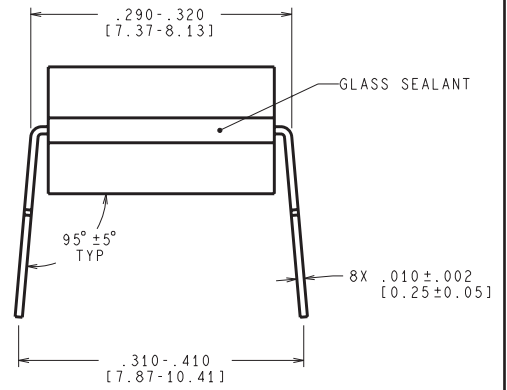
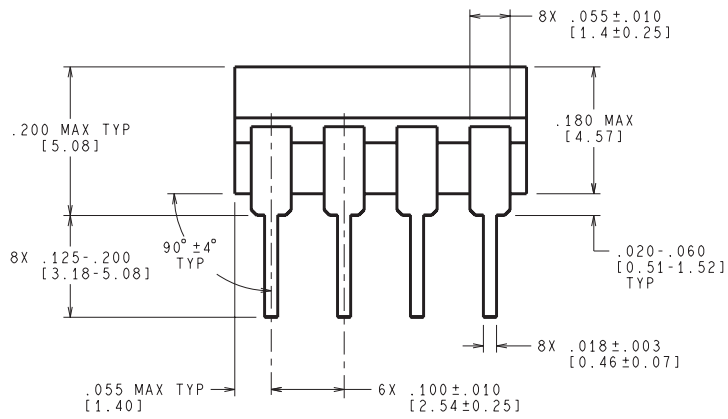

J08A (Rev M)

## IMPORTANT NOTICE

Texas Instruments Incorporated and its subsidiaries (TI) reserve the right to make corrections, enhancements, improvements and other changes to its semiconductor products and services per JESD46, latest issue, and to discontinue any product or service per JESD48, latest issue. Buyers should obtain the latest relevant information before placing orders and should verify that such information is current and complete. All semiconductor products (also referred to herein as "components") are sold subject to TI's terms and conditions of sale supplied at the time of order acknowledgment.

TI warrants performance of its components to the specifications applicable at the time of sale, in accordance with the warranty in TI's terms and conditions of sale of semiconductor products. Testing and other quality control techniques are used to the extent TI deems necessary to support this warranty. Except where mandated by applicable law, testing of all parameters of each component is not necessarily performed.

TI assumes no liability for applications assistance or the design of Buyers' products. Buyers are responsible for their products and applications using TI components. To minimize the risks associated with Buyers' products and applications, Buyers should provide adequate design and operating safeguards.

TI does not warrant or represent that any license, either express or implied, is granted under any patent right, copyright, mask work right, or other intellectual property right relating to any combination, machine, or process in which TI components or services are used. Information published by TI regarding third-party products or services does not constitute a license to use such products or services or a warranty or endorsement thereof. Use of such information may require a license from a third party under the patents or other intellectual property of the third party, or a license from TI under the patents or other intellectual property of TI.

Reproduction of significant portions of TI information in TI data books or data sheets is permissible only if reproduction is without alteration and is accompanied by all associated warranties, conditions, limitations, and notices. TI is not responsible or liable for such altered documentation. Information of third parties may be subject to additional restrictions.

Resale of TI components or services with statements different from or beyond the parameters stated by TI for that component or service voids all express and any implied warranties for the associated TI component or service and is an unfair and deceptive business practice. TI is not responsible or liable for any such statements.

Buyer acknowledges and agrees that it is solely responsible for compliance with all legal, regulatory and safety-related requirements concerning its products, and any use of TI components in its applications, notwithstanding any applications-related information or support that may be provided by TI. Buyer represents and agrees that it has all the necessary expertise to create and implement safeguards which anticipate dangerous consequences of failures, monitor failures and their consequences, lessen the likelihood of failures that might cause harm and take appropriate remedial actions. Buyer will fully indemnify TI and its representatives against any damages arising out of the use of any TI components in safety-critical applications.

In some cases, TI components may be promoted specifically to facilitate safety-related applications. With such components, TI's goal is to help enable customers to design and create their own end-product solutions that meet applicable functional safety standards and requirements. Nonetheless, such components are subject to these terms.

No TI components are authorized for use in FDA Class III (or similar life-critical medical equipment) unless authorized officers of the parties have executed a special agreement specifically governing such use.

Only those TI components which TI has specifically designated as military grade or "enhanced plastic" are designed and intended for use in military/aerospace applications or environments. Buyer acknowledges and agrees that any military or aerospace use of TI components which have **not** been so designated is solely at the Buyer's risk, and that Buyer is solely responsible for compliance with all legal and regulatory requirements in connection with such use.

TI has specifically designated certain components as meeting ISO/TS16949 requirements, mainly for automotive use. In any case of use of non-designated products, TI will not be responsible for any failure to meet ISO/TS16949.

### Products

Audio	<a href="http://www.ti.com/audio">www.ti.com/audio</a>
Amplifiers	<a href="http://amplifier.ti.com">amplifier.ti.com</a>
Data Converters	<a href="http://dataconverter.ti.com">dataconverter.ti.com</a>
DLP® Products	<a href="http://www.dlp.com">www.dlp.com</a>
DSP	<a href="http://dsp.ti.com">dsp.ti.com</a>
Clocks and Timers	<a href="http://www.ti.com/clocks">www.ti.com/clocks</a>
Interface	<a href="http://interface.ti.com">interface.ti.com</a>
Logic	<a href="http://logic.ti.com">logic.ti.com</a>
Power Mgmt	<a href="http://power.ti.com">power.ti.com</a>
Microcontrollers	<a href="http://microcontroller.ti.com">microcontroller.ti.com</a>
RFID	<a href="http://www.ti-rfid.com">www.ti-rfid.com</a>
OMAP Applications Processors	<a href="http://www.ti.com/omap">www.ti.com/omap</a>
Wireless Connectivity	<a href="http://www.ti.com/wirelessconnectivity">www.ti.com/wirelessconnectivity</a>

### Applications

Automotive and Transportation	<a href="http://www.ti.com/automotive">www.ti.com/automotive</a>
Communications and Telecom	<a href="http://www.ti.com/communications">www.ti.com/communications</a>
Computers and Peripherals	<a href="http://www.ti.com/computers">www.ti.com/computers</a>
Consumer Electronics	<a href="http://www.ti.com/consumer-apps">www.ti.com/consumer-apps</a>
Energy and Lighting	<a href="http://www.ti.com/energy">www.ti.com/energy</a>
Industrial	<a href="http://www.ti.com/industrial">www.ti.com/industrial</a>
Medical	<a href="http://www.ti.com/medical">www.ti.com/medical</a>
Security	<a href="http://www.ti.com/security">www.ti.com/security</a>
Space, Avionics and Defense	<a href="http://www.ti.com/space-avionics-defense">www.ti.com/space-avionics-defense</a>
Video and Imaging	<a href="http://www.ti.com/video">www.ti.com/video</a>

### TI E2E Community

[e2e.ti.com](http://e2e.ti.com)