



PCM1720

SoundPlus Stereo Audio DIGITAL-TO-ANALOG CONVERTER MPEG2/AC-3 COMPATIBLE

FEATURES

- ACCEPTS 16-, 20-, OR 24-BIT INPUT DATA
COMPLETE STEREO DAC: Includes Digital Filter and Output Amp
DYNAMIC RANGE: 96dB
MULTIPLE SAMPLING FREQUENCIES: 16kHz to 96kHz
8X Oversampling at All Sampling Frequencies
SYSTEM CLOCK: 256fs/384fs
NORMAL OR I2S DATA INPUT FORMATS
SELECTABLE FUNCTIONS: Soft Mute, Digital Attenuator (256 Steps), Digital De-emphasis
OUTPUT MODE: Left, Right, Mono, Mute

DESCRIPTION

The PCM1720 is a complete low cost stereo audio digital-to-analog converter (DAC), operating off of a 256fs or 384fs system clock. The DAC contains a 3rd-order Delta-Sigma modulator, a digital interpolation filter, and an analog output amplifier. The PCM1720 can accept 16-, 20-, or 24-bit input data in either normal or I2S formats. The digital filter performs an 8X interpolation function and includes selectable features such as soft mute, digital attenuation and digital de-emphasis. The PCM1720 can accept standard digital audio sampling frequencies as well as one-half and double sampling frequencies. The PCM1720 is ideal for applications which combine compressed audio and video data such as DVD, DVD-ROM, set-top boxes and MPEG sound cards.

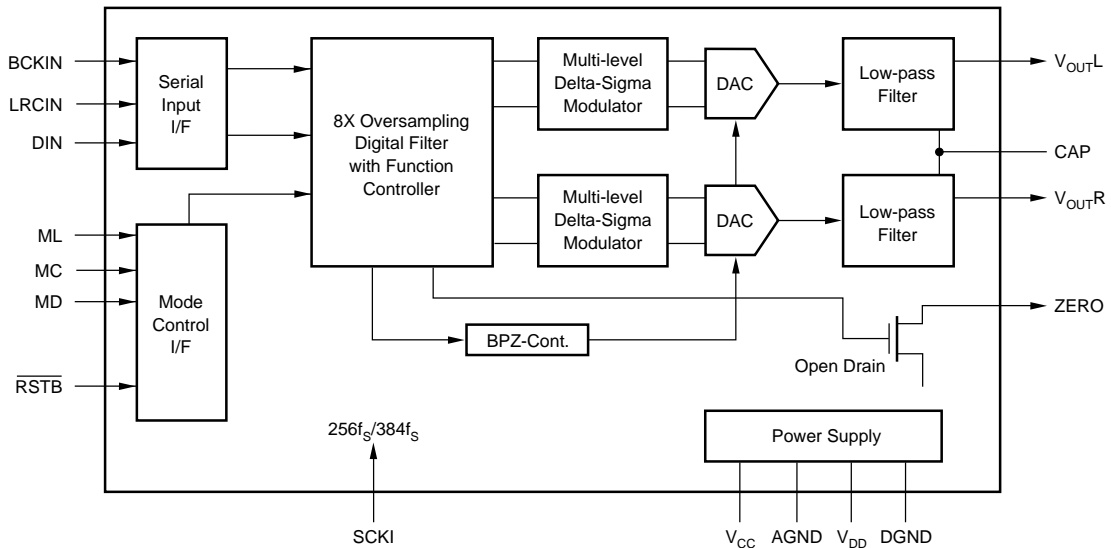

International Airport Industrial Park • Mailing Address: PO Box 11400, Tucson, AZ 85734 • Street Address: 6730 S. Tucson Blvd., Tucson, AZ 85706 • Tel: (520) 746-1111 • Twx: 910-952-1111 Internet: http://www.burr-brown.com/ • FAXLine: (800) 548-6133 (US/Canada Only) • Cable: BBRCORP • Telex: 066-6491 • FAX: (520) 889-1510 • Immediate Product Info: (800) 548-6132

SPECIFICATIONS

All specifications at +25°C, +V_{CC} = +V_{DD} = +5V, f_S = 44.1kHz, and 16-bit input data, SYSCLK = 384f_S, unless otherwise noted.

PARAMETER	CONDITIONS	PCM1720			UNITS
		MIN	TYP	MAX	
RESOLUTION		16		24	Bits
DATA FORMAT Audio Data Format Data Bit Length			Standard/I ² S 16/20/24 Selectable		
Sampling Frequency (f _S)	Standard f _S	32	44.1	48	kHz
	One-half f _S	16	22.05	24	kHz
	Double f _S	64	88.2	96	kHz
Internal System Clock Frequency			256f _S /384f _S		
DIGITAL INPUT/OUTPUT LOGIC LEVEL			TTL		
DYNAMIC PERFORMANCE⁽¹⁾					
THD+N at f _S (0dB)	f _S = 44.1kHz		-90	-80	dB
	f _S = 96kHz		-88		dB
THD+N at -60dB	f _S = 44.1kHz		-34		dB
	f _S = 96kHz		-31		dB
Dynamic Range	f _S = 44.1kHz	90	96		dB
	f _S = 96kHz		93		dB
Signal-to-Noise Ratio ⁽²⁾	f _S = 44.1kHz	92	100		dB
	f _S = 96kHz		97		dB
Channel Separation	f _S = 44.1kHz	90	97		dB
DC ACCURACY					
Gain Error			±1.0	±5.0	% of FSR
Gain Mismatch, Channel-to-Channel			±1.0	±5.0	% of FSR
Bipolar Zero Error	V _{OUT} = V _{CC} /2 at BPZ		±30		mV
ANALOG OUTPUT					
Output Voltage	Full Scale (0dB)		0.62 x V _{CC}		V _{p-p}
Center Voltage			V _{CC} /2		VDC
Load Impedance	AC Load	5			kΩ
DIGITAL FILTER PERFORMANCE					
Passband				0.445	f _S
Stopband		0.555			f _S
Passband Ripple				±0.17	dB
Stopband Attenuation		-35			dB
Delay Time			11.125/f _S		sec
De-emphasis Error		-0.2		+0.55	dB
INTERNAL ANALOG FILTER					
-3dB Bandwidth			100		kHz
Passband Response	f = 20kHz		-0.16		dB
POWER SUPPLY REQUIREMENTS					
Voltage Range	V _{DD} , V _{CC}	4.5	5	5.5	VDC
Supply Current: I _{CC} + I _{DD}	V _{CC} = V _{DD} = 5V, f _S = 44.1kHz		18	25	mA
	V _{CC} = V _{DD} = 5V, f _S = 96kHz		25	35	mA
TEMPERATURE RANGE					
Operation		-25		+85	°C
Storage		-55		+100	°C

NOTES: (1) Dynamic performance specs are tested with 20kHz low pass filter and THD+N specs are tested with 30kHz LPF, 400Hz HPF, Average-Mode. (2) SNR is tested with Infinite Zero Detection off.

The information provided herein is believed to be reliable; however, BURR-BROWN assumes no responsibility for inaccuracies or omissions. BURR-BROWN assumes no responsibility for the use of this information, and all use of such information shall be entirely at the user's own risk. Prices and specifications are subject to change without notice. No patent rights or licenses to any of the circuits described herein are implied or granted to any third party. BURR-BROWN does not authorize or warrant any BURR-BROWN product for use in life support devices and/or systems.

PIN CONFIGURATION

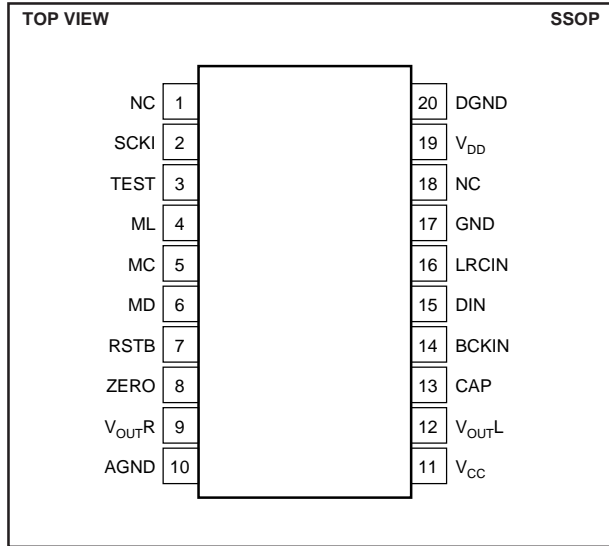

PACKAGE INFORMATION

PRODUCT	PACKAGE	PACKAGE DRAWING NUMBER ⁽¹⁾
PCM1720	20-Pin SSOP	334-1

NOTE: (1) For detailed drawing and dimension table, please see end of data sheet, or Appendix C of Burr-Brown IC Data Book.

ABSOLUTE MAXIMUM RATINGS

Power Supply Voltage	+6.5V
+V _{CC} to +V _{DD} Difference	±0.1V
Input Logic Voltage	-0.3V to (V _{DD} + 0.3V)
Power Dissipation	300mW
Operating Temperature Range	-25°C to +85°C
Storage Temperature	-55°C to +125°C
Lead Temperature (soldering, 5s)	+260°C
Thermal Resistance, θ_{JA}	+70°C/W

PIN ASSIGNMENTS

PIN	NAME	TYPE	FUNCTION
1	NC	—	No Connection.
2	SCKI	IN	System Clock Input: 256f _S or 384f _S .
3	TEST	OUT	Reserved for Factory Use.
4*	ML	IN	Latch Enable for Serial Control Data.
5*	MC	IN	Clock for Serial Control Data.
6*	MD	IN	Data Input for Serial Control.
7*	RSTB	IN	Reset Input. When this pin is low, the digital filters and modulators are held in reset.
8	ZERO	OUT	Zero Data Flag. This pin is low when the data is continuously zero for more than 65,535 cycles of BCKIN.
9	V _{OUTR}	OUT	Right Channel Analog Output.
10	AGND	PWR	Analog Ground.
11	V _{CC}	PWR	Analog Power Supply (+5V).
12	V _{OUTL}	OUT	Left Channel Analog Output.
13	CAP	—	Common Pin for Analog Output Amplifiers.
14*	BCKIN	IN	Bit Clock for Clocking in the Audio Data.
15*	DIN	IN	Serial Audio Data Input.
16*	LRCIN	IN	Left/Right Word Clock. Frequency is equal to fs.
17	GND	PWR	Ground.
18	NC	—	No Connection.
19	V _{DD}	PWR	Digital Power Supply (+5V). Recommended connection is to the analog power supply.
20	DGND	PWR	Digital Ground. Recommended connection is to the digital ground plane.

* These pins include internal pull-up resistors.

ELECTROSTATIC DISCHARGE SENSITIVITY

This integrated circuit can be damaged by ESD. Burr-Brown recommends that all integrated circuits be handled with appropriate precautions. Failure to observe proper handling and installation procedures can cause damage.

ESD damage can range from subtle performance degradation to complete device failure. Precision integrated circuits may be more susceptible to damage because very small parametric changes could cause the device not to meet its published specifications.

TYPICAL PERFORMANCE CURVES

At $T_A = +25^\circ\text{C}$, $V_{CC} = V_{DD} = +5\text{V}$, $f_s = 44.1\text{kHz}$, 16-bit input data, unless otherwise noted. Measurement bandwidth is 20kHz

DYNAMIC PERFORMANCE

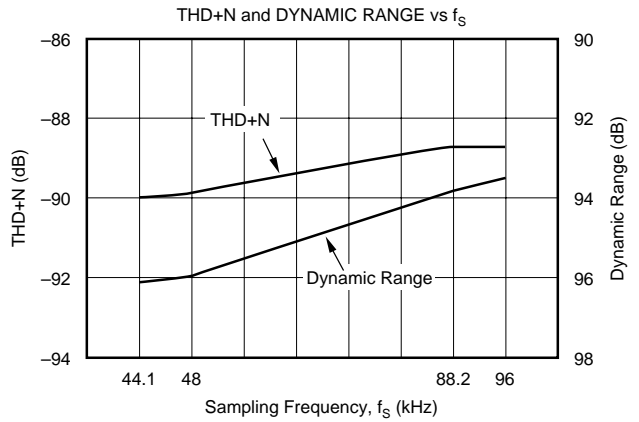
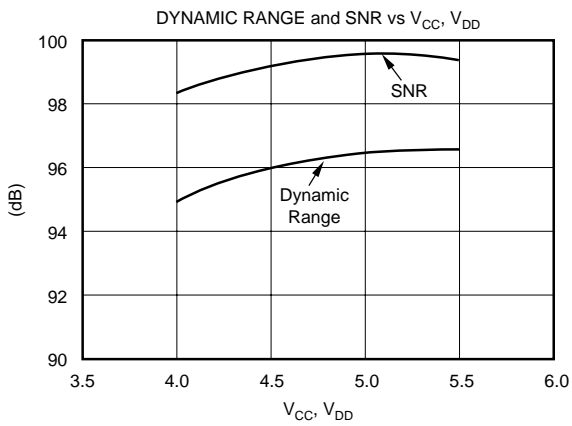
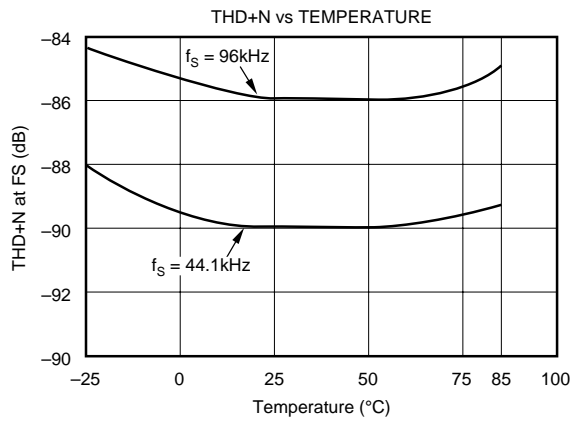
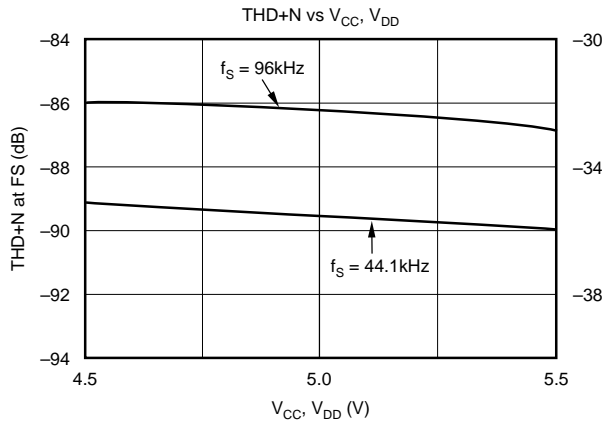

TYPICAL PERFORMANCE CURVES

At $T_A = +25^\circ\text{C}$, $V_{CC} = V_{DD} = +5\text{V}$, $R_L = 44.1\text{kHz}$, $f_{\text{SYS}} = 384f_s$, and 16-bit input data, unless otherwise noted.

DIGITAL FILTER

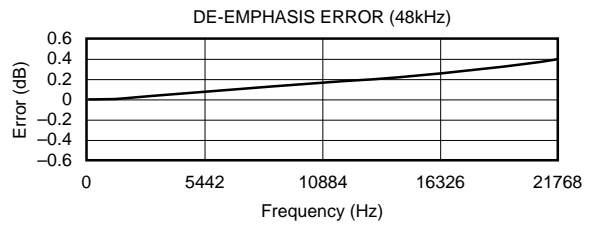
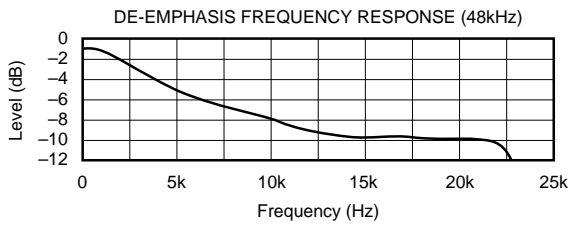
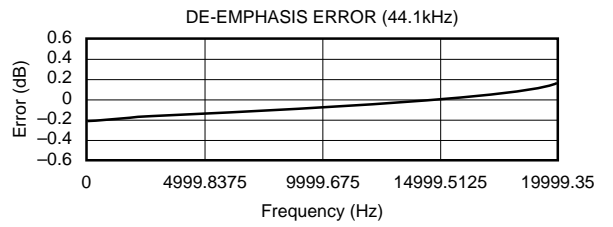
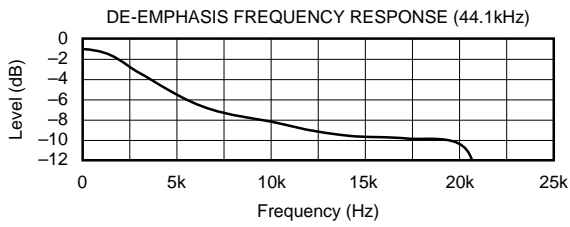
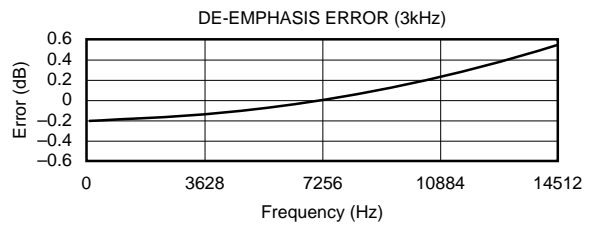
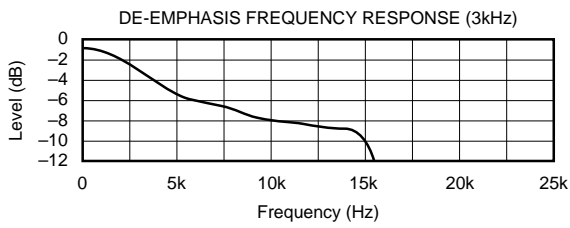
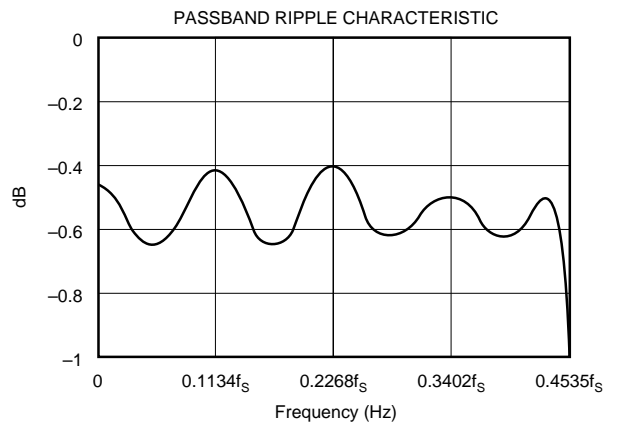
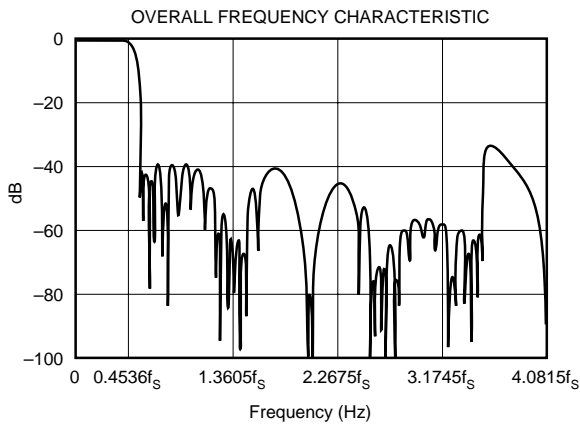

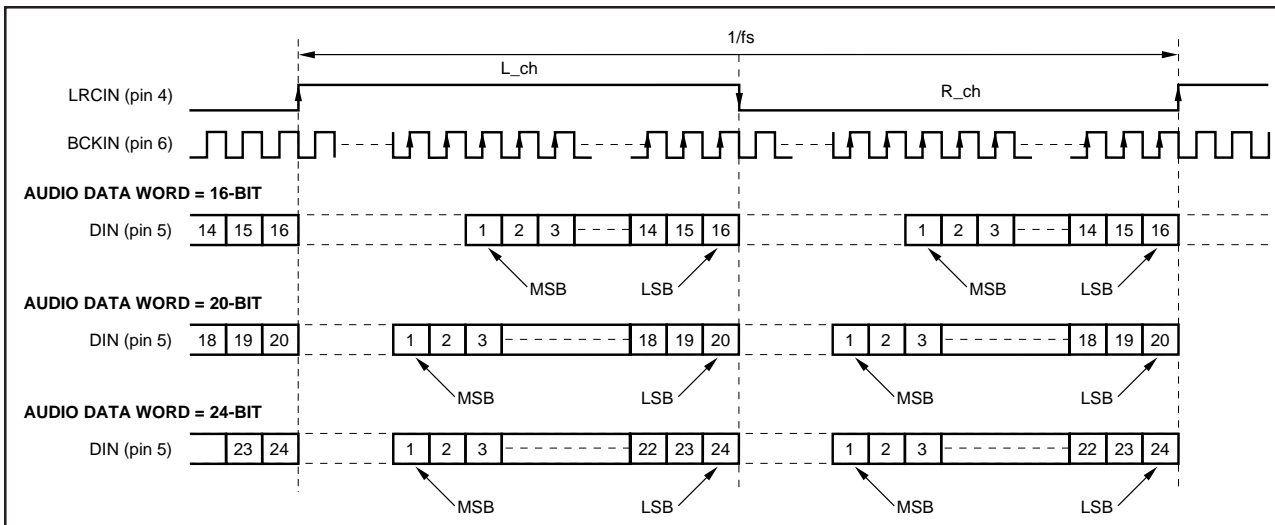

FIGURE 1. "Normal" Data Input Timing.

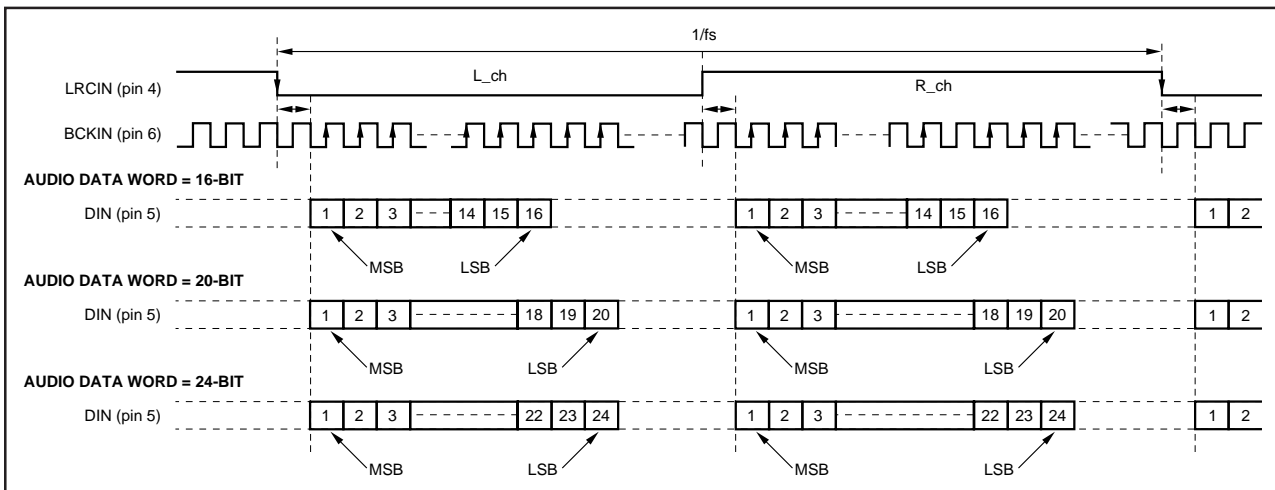

FIGURE 2. "I²S" Data Input Timing.

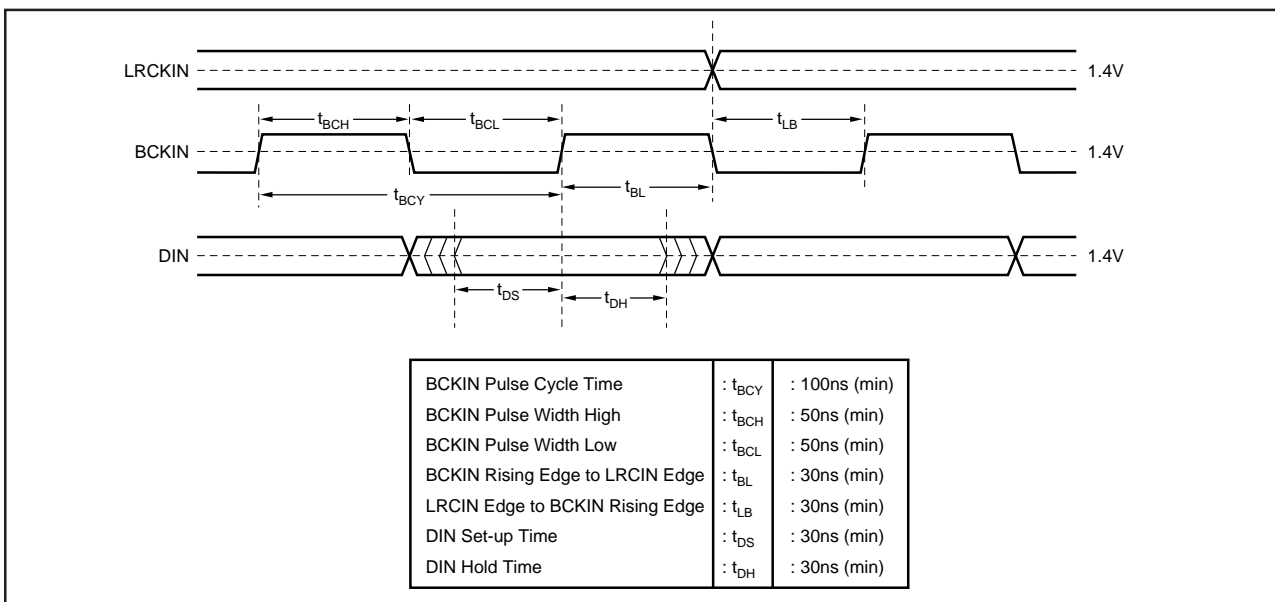

FIGURE 3. Audio Data Input Timing.

TYPICAL CONNECTION DIAGRAM

Figure 4 illustrates the typical connection diagram for PCM1720 used in a stand-alone application.

SYSTEM CLOCK

The system clock for PCM1720 must be either $256f_s$ or $384f_s$, where f_s is the audio sampling frequency (LRCIN), typically 32kHz, 44.1kHz or 48kHz. The system clock is used to operate the digital filter and the noise shaper. The system clock input (SCKI) is at pin 2.

PCM1720 has a system clock detection circuit which automatically detects the frequency, either $256f_s$ or $384f_s$. The system clock should be synchronized with LRCIN (pin 16), but PCM1720 can compensate for phase differences. If the phase difference between LRCIN and system clock is greater than ± 6 bit clocks (BCKIN), the synchronization is performed automatically. The analog outputs are forced to a bipolar zero state ($V_{CC}/2$) during the synchronization function. Table I shows the typical system clock frequency inputs for the PCM1720.

SAMPLING RATE (LRCIN)	SYSTEM CLOCK FREQUENCY (MHz)	
	$256f_s$	$384f_s$
32kHz	8.192	12.288
44.1kHz	11.2896	16.9340
48kHz	12.288	18.432

TABLE I. System Clock Frequencies vs Sampling Rate.

SPECIAL FUNCTIONS

PCM1720 includes several special functions, including digital attenuation, digital de-emphasis, soft mute, data format selection and input word resolution. These functions are controlled using a three-wire interface. MD (pin 6) is used for the program data, MC (pin 5) is used to clock in the program data, and ML (pin 4) is used to latch in the program data. Table II lists the selectable special functions.

FUNCTION	DEFAULT MODE
Input Audio Data Format Selection Normal Format I ² S Format	Normal Format
Input Audio Data Bit Selection 16/20/24 Bits	16 Bits
Input LRCIN Polarity Selection Lch/Rch = High/Low Lch/Rch = Low/High	Lch/Rch = High/Low
De-emphasis Control	OFF
Soft Mute Control	OFF
Attenuation Control Lch, Rch Individually Lch, Rch Common	0dB Lch, Rch Individually Fixed
Infinite Zero Detection Circuit Control	OFF
Operation Enable (OPE)	Enabled
Sample Rate Selection Internal System Clock Selection $256f_s$ $384f_s$ Sampling Frequency 44.1kHz Group 48kHz Group 32kHz Group	$384f_s$ 44.1kHz
Analog Output Mode L, R, Mono, Mute	Stereo

TABLE II. Selectable Functions.

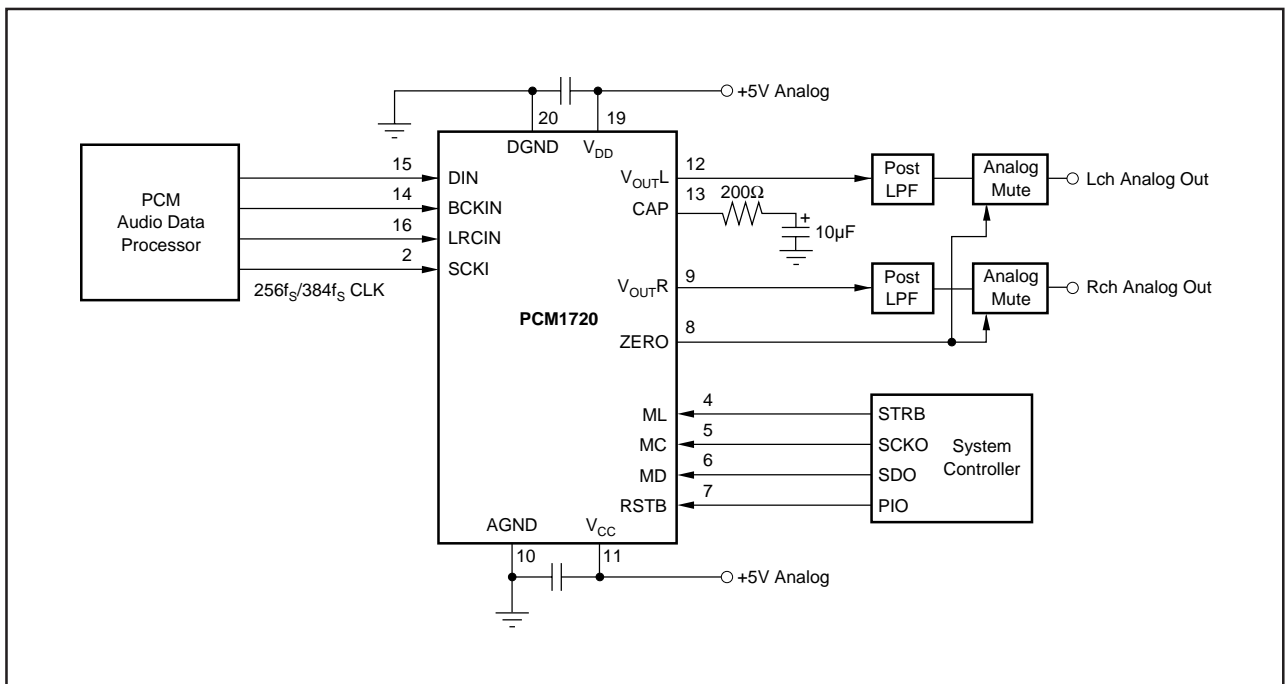

FIGURE 4. Typical Connection Diagram.

MAPPING OF PROGRAM REGISTERS

	B15	B14	B13	B12	B11	B10	B9	B8	B7	B6	B5	B4	B3	B2	B1	B0
REGISTER 0	res	res	res	res	res	A1	A0	LDL	AL7	AL6	AL5	AL4	AL3	AL2	AL1	AL0
REGISTER 1	res	res	res	res	res	A1	A0	LDR	AR7	AR6	AR5	AR4	AR3	AR2	AR1	AR0
REGISTER 2	res	res	res	res	res	A1	A0	PL3	PL2	PL1	PL0	IW1	IW0	OPE	DEM	MUT
REGISTER 3	res	res	res	res	res	A1	A0	IZD	SF1	SF0	res	res	res	ATC	LRP	I ² S

PROGRAM REGISTER BIT MAPPING

PCM1720's special functions are controlled using four program registers which are 16 bits long. These registers are all loaded using MD. After the 16 data bits are clocked in, ML is used to latch in the data to the appropriate register. Table III shows the complete mapping of the four registers and Figure 6 illustrates the data input timing.

REGISTER NAME	BIT NAME	DESCRIPTION
Register 0	AL (7:0) LDL A (1:0) res	DAC Attenuation Data for Lch Attenuation Data Load Control for Lch Register Address Reserved
Register 1	AR (7:0) LDL A (1:0) res	DAC Attenuation Data for Rch Attenuation Data Load Control for Rch Register Address Reserved
Register 2	MUT DEM OPE IW (1:0) PL (3:0) A (1:0) res	Left and Right DACs Soft Mute Control De-emphasis Control Left and Right DACs Operation Control Input Audio Data Bit Select Output Mode Select Register Address Reserved
Register 3	I ² S LRP ATC SYS SF (1:0) IZD A (1:0) res	Audio Data Format Select Polarity of LRCIN (pin 7) Select Attenuator Control System Clock Select Sampling Rate Select Infinite Zero Detection Circuit Control Register Address Reserved

TABLE III. Internal Register Mapping.

REGISTER 0 (A1 = 0, A0 = 0)

B15	B14	B13	B12	B11	B10	B9	B8	B7	B6	B5	B4	B3	B2	B1	B0
res	res	res	res	res	A1	A0	LDL	AL7	AL6	AL5	AL4	AL3	AL2	AL1	AL0

Register 0 is used to control left channel attenuation. Bits 0 - 7 (AL0 - AL7) are used to determine the attenuation level. The level of attenuation is given by:

$$ATT = [20 \log_{10} (ATT_DATA/255)] \text{ dB}$$

ATTENUATION DATA LOAD CONTROL, LCH

Bit 8 (LDL) is used to simultaneously set analog outputs of Lch and Rch. An output level is controlled by AL[0:7] attenuation data when this bit is set to 1. When set to 0, an output level is not controlled and remains at the previous attenuation level. A LDR bit in Register 1 has an equivalent function as the LDL. When one of LDL or LDR is set to 1, the output level of the left and right channel is simultaneously controlled. The attenuation level is given by:

$$ATT = 20 \log (y/256) \text{ (dB)}, \text{ where } y = x, \text{ when } 0 \leq x \leq 254$$

$$y = x + 1, \text{ when } x = 255$$

X is the user-determined step number, an integer value between 0 and 255.

Example:

let $x = 255$

$$ATT = 20 \log \left(\frac{255+1}{256} \right) = 0 \text{ dB}$$

let $x = 254$

$$ATT = 20 \log \left(\frac{254}{256} \right) = -0.068 \text{ dB}$$

let $x = 1$

$$ATT = 20 \log \left(\frac{1}{256} \right) = -48.16 \text{ dB}$$

let $x = 0$

$$ATT = 20 \log \left(\frac{0}{256} \right) = -\infty$$

REGISTER 1 (A1 = 0, A0 = 1)

B15	B14	B13	B12	B11	B10	B9	B8	B7	B6	B5	B4	B3	B2	B1	B0
res	res	res	res	res	A1	A0	LDR	AR7	AR6	AR5	AR4	AR3	AR2	AR1	AR0

Register 1 is used to control right channel attenuation. As in Register 1, bits 0 - 7 (AR0 - AR7) control the level of attenuation.

REGISTER 2 (A1 = 1, A0 = 0)

B15	B14	B13	B12	B11	B10	B9	B8	B7	B6	B5	B4	B3	B2	B1	B0
res	res	res	res	res	A1	A0	PL3	PL2	PL1	PL0	IW1	IW0	OPE	DEM	MUTE

Register 2 is used to control soft mute, de-emphasis, operation enable, input resolution, and output format. Bit 0 is used for soft mute: a “HIGH” level on bit 0 will cause the output to be muted (this is ramped down in the digital domain, so no “click” is audible). Bit 1 is used to control de-emphasis. A “LOW” level on bit 1 disables de-emphasis, while a “HIGH” level enables de-emphasis.

Bit 2, (OPE) is used for operational control. Table IV illustrates the features controlled by OPE.

	DATA INPUT	DAC OUTPUT	SOFTWARE MODE INPUT
OPE = 1	Zero	Forced to BPZ ⁽¹⁾	Enabled
	Other	Forced to BPZ ⁽¹⁾	Enabled
OPE = 0	Zero	Controlled by IZD	Enabled
	Other	Normal	Enabled

TABLE IV. Output Enable (OPE) Function.

OPE controls the operation of the DAC: when OPE is “LOW”, the DAC will convert all non-zero input data. If the input data is continuously zero for 65, 536 cycles of BCKIN, the output will be forced to zero only if IZD is “HIGH”. When OPE is “HIGH”, the output of the DAC will be forced to bipolar zero, irrespective of any input data.

	DATA INPUT	DAC OUTPUT
IZD = 1	Zero	Forced to BPZ ⁽¹⁾
	Other	Normal
IZD = 0	Zero	Zero ⁽²⁾
	Other	Normal

TABLE V. Infinite Zero Detection (IZD) Function.

	DATA INPUT	DAC OUTPUT	SOFTWARE MODE INPUT
RSTB = “HIGH”	Zero	Controlled by OPE and IZD	Enabled
	Other	Controlled by OPE and IZD	Enabled
RSTB = “LOW”	Zero	Forced to BPZ ⁽¹⁾	Disabled
	Other	Forced to BPZ ⁽¹⁾	Disabled

TABLE VI. Reset (RSTB) Function.

NOTE: (1) $\Delta\Sigma$ is disconnected from output amplifier. (2) $\Delta\Sigma$ is connected to output amplifier.

Bits 3 (IW0) and 4 (IW1) are used to determine input word resolution. PCM1720 can be set up for input word resolutions of 16, 20, or 24 bits:

Bit 4 (IW1)	Bit 3 (IW0)	Input Resolution
0	0	16-bit Data Word
0	1	20-bit Data Word
1	0	24-bit Data Word
0	0	Reserved

Bits 5, 6, 7, and 8 (PL0:3) are used to control output format. The output of PCM1720 can be programmed for 16 different states, as shown in Table VII.

PL0	PL1	PL2	PL3	Lch OUTPUT	Rch OUTPUT	NOTE
0	0	0	0	MUTE	MUTE	MUTE
0	0	0	1	MUTE	R	
0	0	1	0	MUTE	L	
0	0	1	1	MUTE	(L + R)/2	
0	1	0	0	R	MUTE	
0	1	0	1	R	R	
0	1	1	0	R	L	REVERSE
0	1	1	1	R	(L + R)/2	
1	0	0	0	L	MUTE	
1	0	0	1	L	R	STEREO
1	0	1	0	L	L	
1	0	1	1	L	(L + R)/2	
1	1	0	0	(L + R)/2	MUTE	
1	1	0	1	(L + R)/2	R	
1	1	1	0	(L + R)/2	L	
1	1	1	1	(L + R)/2	(L + R)/2	MONO

TABLE VII. Programmable Output Format.

REGISTER 3 (A1 = 1, A0 = 1)

B15	B14	B13	B12	B11	B10	B9	B8	B7	B6	B5	B4	B3	B2	B1	B0
res	res	res	res	res	A1	A0	IZD	SF1	SF0	res	res	res	ATC	LRP	I ² S

Register 3 is used to control input data format and polarity, attenuation channel control, system clock frequency, sampling frequency and infinite zero detection.

Bits 0 (I²S) and 1 (LRP) are used to control the input data format. A “LOW” on bit 0 sets the format to “Normal” (MSB-first, right-justified Japanese format) and a “HIGH” sets the format to I²S (Philips serial data protocol). Bit 1 (LRP) is used to select the polarity of LRCIN (sample rate clock). When bit 1 is “LOW”, left channel data is assumed when LRCIN is in a “HIGH” phase and right channel data is assumed when LRCIN is in a “LOW” phase. When bit 1 is “HIGH”, the polarity assumption is reversed.

Bit 2 (ATC) is used for controlling the attenuator. When bit 2 is “HIGH”, the attenuation data loaded in program Register 0 is used for both left and right channels. When bit 2 is “LOW”, the attenuation data for each register is applied separately to left and right channels.

Bits 6 (SF0) and 7 (SF1) are used to select the sampling frequency:

SF1	SF0	Sampling Frequency	
0	0	44.1kHz group	22.05/44.1/88.2kHz
0	1	48kHz group	24/48/96kHz
1	0	32kHz group	16/32/64kHz
1	1	Reserved	Not Defined

Bit 8 is used to control the infinite zero detection function (IZD).

When IZD is “LOW”, the zero detect circuit is off. Under this condition, no automatic muting will occur if the input is continuously zero. When IZD is “HIGH”, the zero detect feature is enabled. If the input data is continuously zero for 65, 536 cycles of BCKIN, the output will be immediately forced to a bipolar zero state ($V_{CC}/2$). The zero detection

feature is used to avoid noise which may occur when the input is DC. When the output is forced to bipolar zero, there may be an audible click. PCM1720 allows the zero detect feature to be disabled so the user can implement external muting circuit.

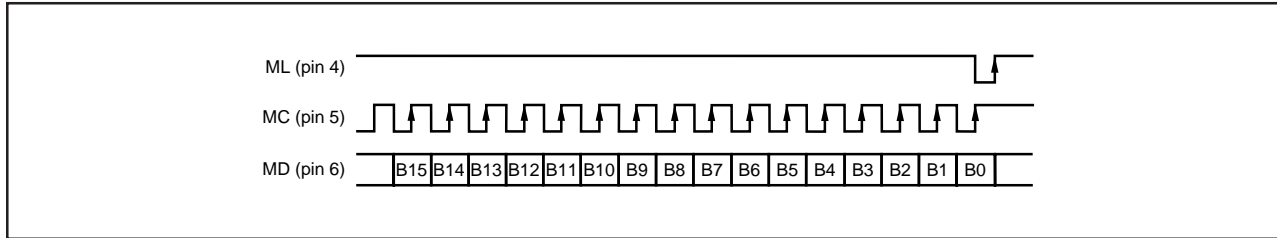

FIGURE 5. Serial Interface Timing.

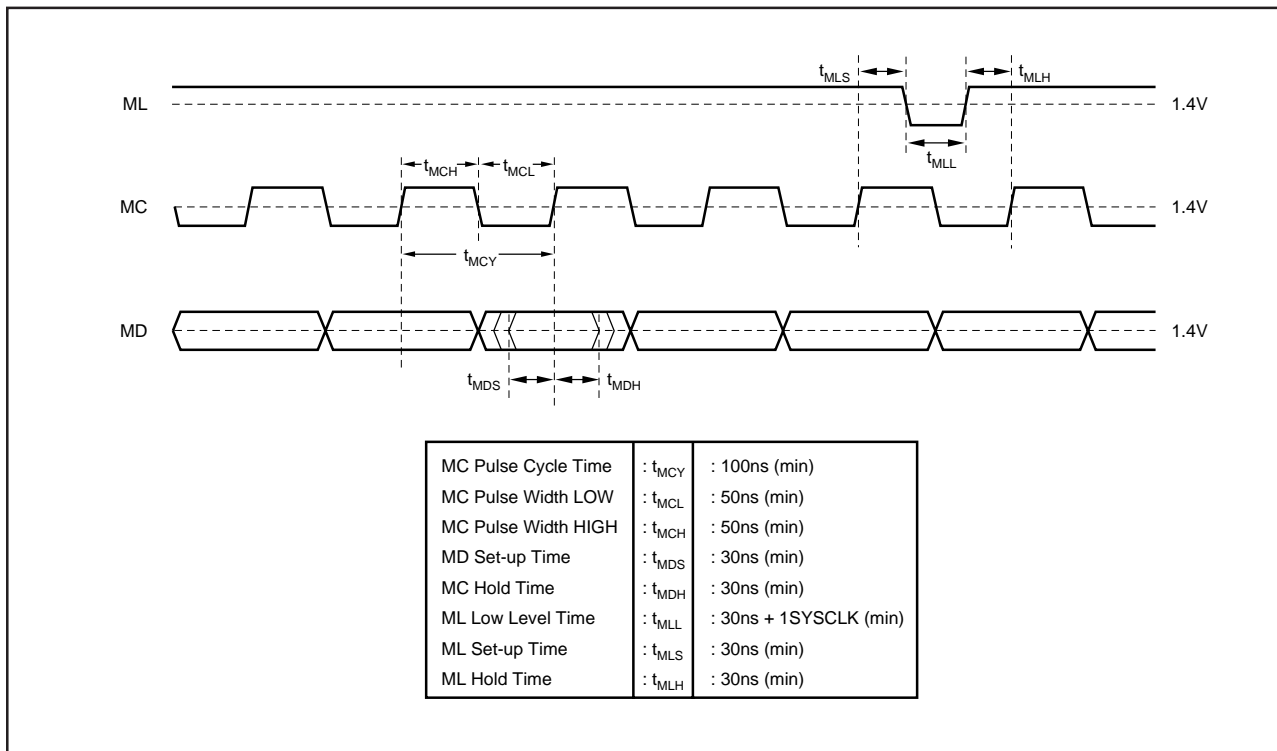

FIGURE 6. Program Register Input Timing.

APPLICATION CONSIDERATIONS

DELAY TIME

There is a finite delay time in delta-sigma converters. In A/D converters, this is commonly referred to as latency. For a delta-sigma D/A converter, delay time is determined by the order number of the FIR filter stage, and the chosen sampling rate. The following equation expresses the delay time of PCM1720:

$$T_D = 11.125 \times 1/f_S$$

For $f_S = 44.1\text{kHz}$, $T_D = 11.125/44.1\text{kHz} = 251.4\mu\text{s}$

Applications using data from a disc or tape source, such as CD audio, CD-Interactive, Video CD, DAT, Minidisc, etc., generally are not affected by delay time. For some professional applications such as broadcast audio for studios, it is important for total delay time to be less than 2ms.

OUTPUT FILTERING

For testing purposes all dynamic tests are done on the PCM1720 using a 20kHz low pass filter. This filter limits the measured bandwidth for THD+N, etc. to 20kHz. Failure to use such a filter will result in higher THD+N and lower SNR and Dynamic Range readings than are found in the specifications. The low pass filter removes out of band noise. Although it is not audible, it may affect dynamic specification numbers.

The performance of the internal low pass filter from DC to 24kHz is shown in Figure 7. The higher frequency rolloff of the filter is shown in Figure 8. If the user's application has the PCM1720 driving a wideband amplifier, it is recommended to use an external low pass filter. A simple 3rd-order filter is shown in Figure 9. For some applications, a passive RC filter or 2nd-order filter may be adequate.

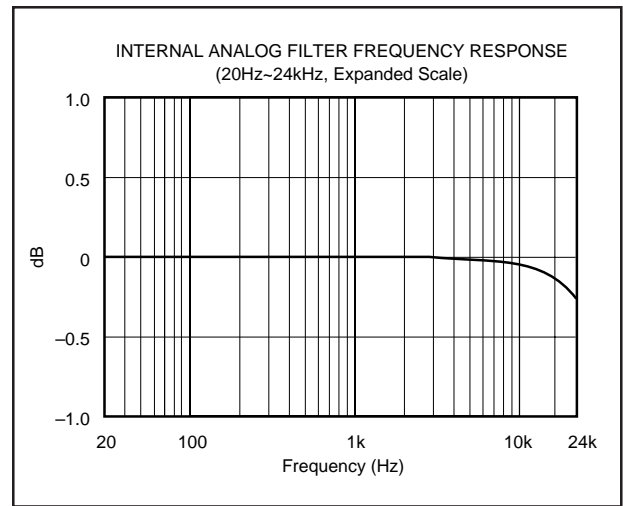

FIGURE 7. Low Pass Filter Frequency Response.

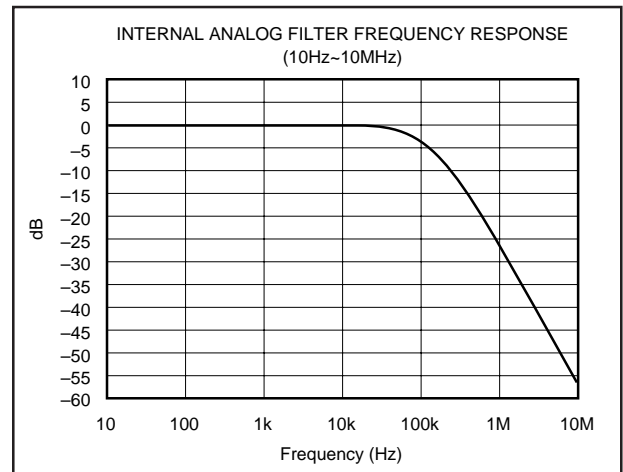

FIGURE 8. Low Pass Filter Wideband Frequency Response.

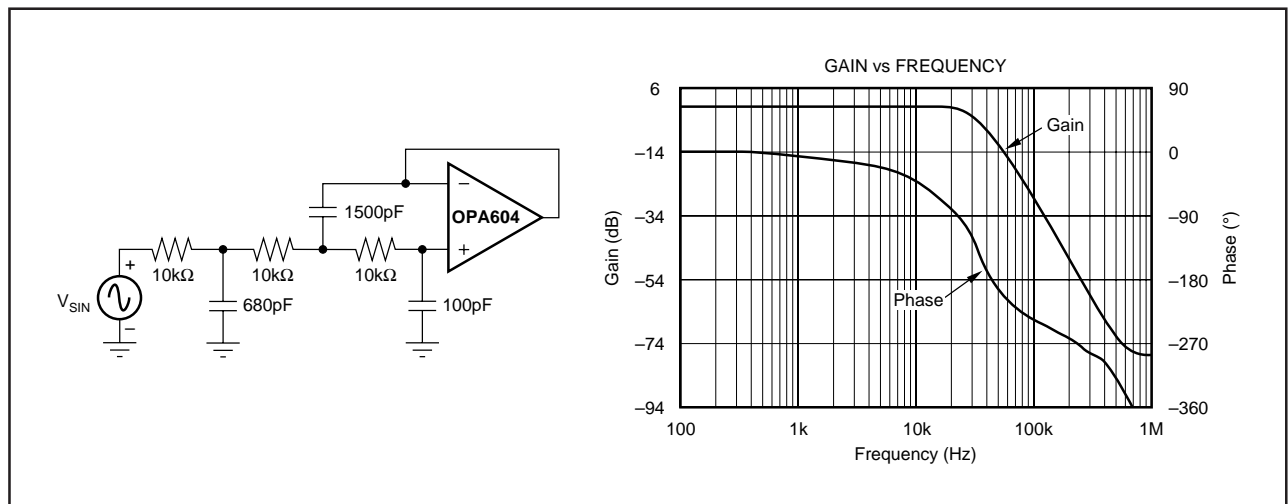

FIGURE 9. 3rd-Order LPF.

POWER SUPPLY CONNECTIONS

PCM1720 has two power supply connections: digital (V_{DD}) and analog (V_{CC}). Each connection also has a separate ground. If the power supplies turn on at different times, there is a possibility of a latch-up condition. To avoid this condition, it is recommended to have a common connection between the digital and analog power supplies. If separate supplies are used without a common connection, the delta between the two supplies during ramp-up time must be less than 0.6V.

An application circuit to avoid a latch-up condition is shown in Figure 10.

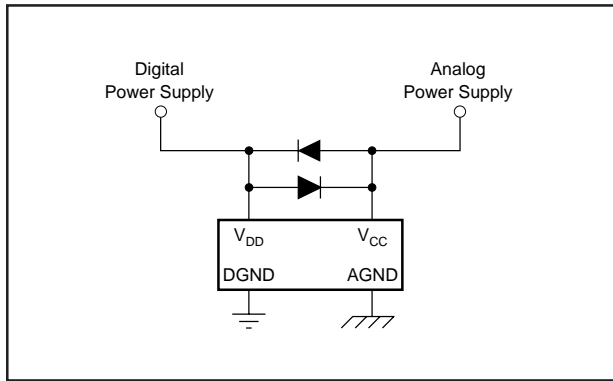

FIGURE 10. Latch-up Prevention Circuit.

BYPASSING POWER SUPPLIES

The power supplies should be bypassed as close as possible to the unit. Refer to Figure 13 for optimal values of bypass capacitors. It is also recommended to include a 0.1μF ceramic capacitor in parallel with the 10μF tantalum capacitor.

THEORY OF OPERATION

The delta-sigma section of PCM1720 is based on a 5-level amplitude quantizer and a 3rd-order noise shaper. This section converts the oversampled input data to 5-level delta-sigma format. A block diagram of the 5-level delta-sigma modulator is shown in Figure 11. This 5-level delta-sigma modulator has the advantage of stability and clock jitter over the typical one-bit (2-level) delta-sigma modulator.

The combined oversampling rate of the delta-sigma modulator and the internal 8X interpolation filter is $48f_s$ for a $384f_s$ system clock, and $64f_s$ for a $256f_s$ system clock. The theoretical quantization noise performance of the 5-level delta-sigma modulator is shown in Figure 12.

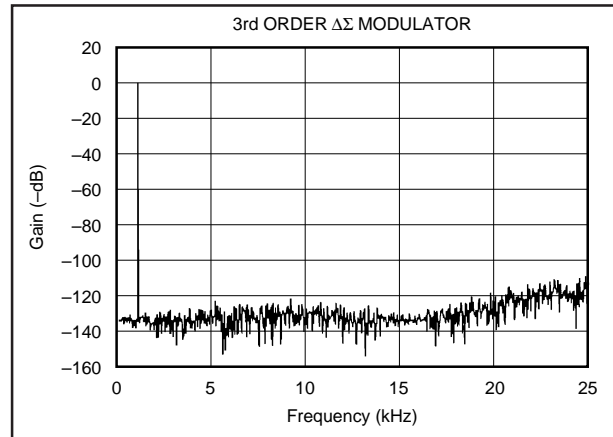

FIGURE 12. Quantization Noise Spectrum.

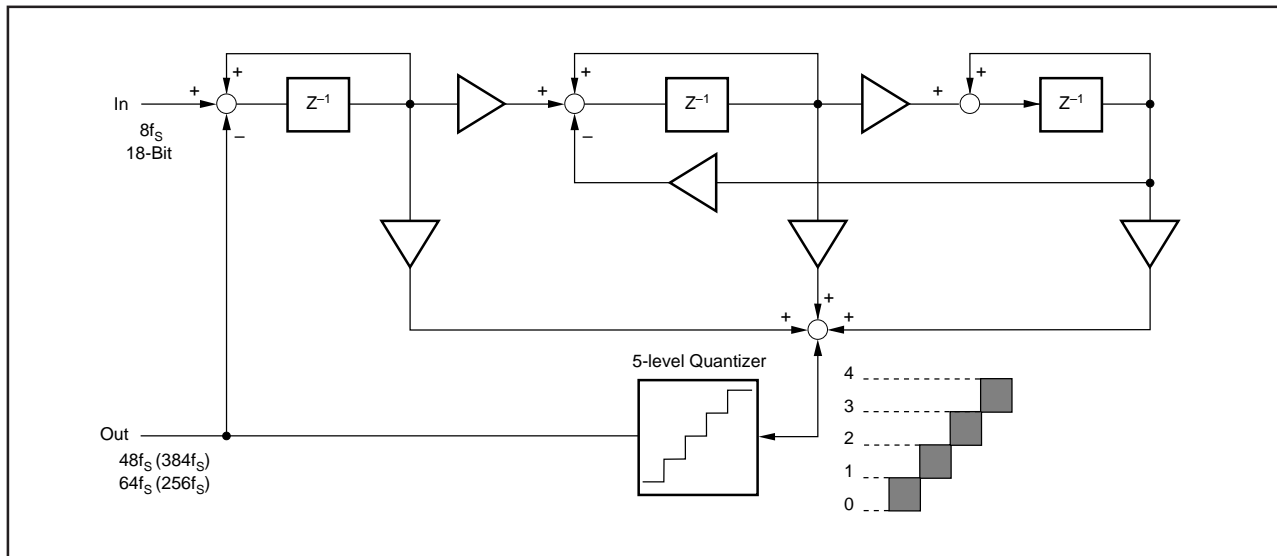

FIGURE 11. 5-Level ΔΣ Modulator Block Diagram.

AC-3 APPLICATION

Figure 13 shows the typical circuit diagram for Dolby AC-3, 5.1 channel system.

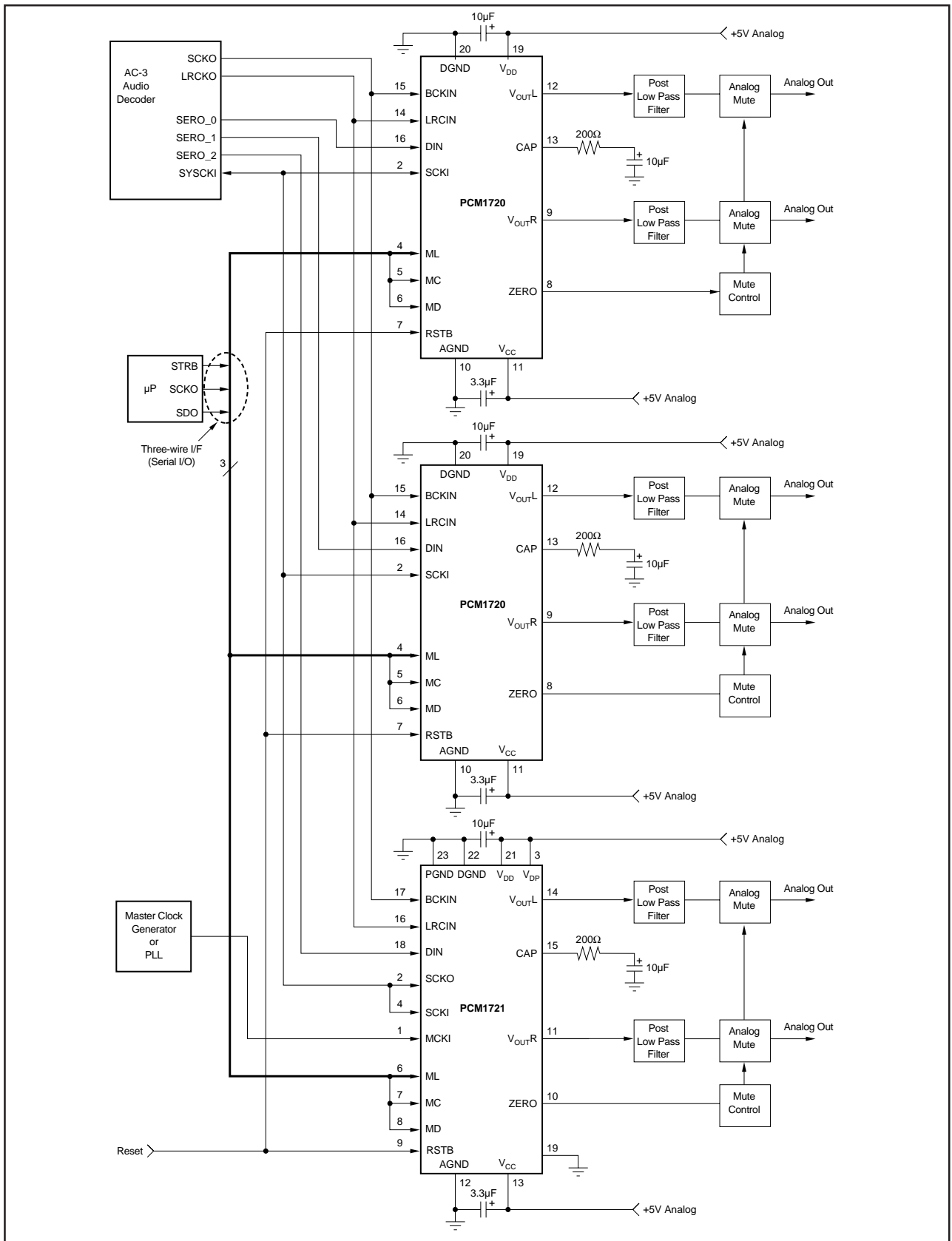

FIGURE 13. Connection Diagram for a 6-Channel AC-3 Application.

PACKAGING INFORMATION

Orderable Device	Status ⁽¹⁾	Package Type	Package Drawing	Pins	Package Qty	Eco Plan ⁽²⁾	Lead/Ball Finish	MSL Peak Temp ⁽³⁾
PCM1720E	ACTIVE	SSOP	DB	20	65	Green (RoHS & no Sb/Br)	CU NIPDAU	Level-1-260C-UNLIM
PCM1720E/2K	ACTIVE	SSOP	DB	20	2000	Green (RoHS & no Sb/Br)	CU NIPDAU	Level-1-260C-UNLIM

⁽¹⁾ The marketing status values are defined as follows:

ACTIVE: Product device recommended for new designs.

LIFEBUY: TI has announced that the device will be discontinued, and a lifetime-buy period is in effect.

NRND: Not recommended for new designs. Device is in production to support existing customers, but TI does not recommend using this part in a new design.

PREVIEW: Device has been announced but is not in production. Samples may or may not be available.

OBsolete: TI has discontinued the production of the device.

⁽²⁾ Eco Plan - May not be currently available - please check <http://www.ti.com/productcontent> for the latest availability information and additional product content details.

None: Not yet available Lead (Pb-Free).

Pb-Free (RoHS): TI's terms "Lead-Free" or "Pb-Free" mean semiconductor products that are compatible with the current RoHS requirements for all 6 substances, including the requirement that lead not exceed 0.1% by weight in homogeneous materials. Where designed to be soldered at high temperatures, TI Pb-Free products are suitable for use in specified lead-free processes.

Green (RoHS & no Sb/Br): TI defines "Green" to mean "Pb-Free" and in addition, uses package materials that do not contain halogens, including bromine (Br) or antimony (Sb) above 0.1% of total product weight.

⁽³⁾ MSL, Peak Temp. -- The Moisture Sensitivity Level rating according to the JEDEC industry standard classifications, and peak solder temperature.

Important Information and Disclaimer: The information provided on this page represents TI's knowledge and belief as of the date that it is provided. TI bases its knowledge and belief on information provided by third parties, and makes no representation or warranty as to the accuracy of such information. Efforts are underway to better integrate information from third parties. TI has taken and continues to take reasonable steps to provide representative and accurate information but may not have conducted destructive testing or chemical analysis on incoming materials and chemicals. TI and TI suppliers consider certain information to be proprietary, and thus CAS numbers and other limited information may not be available for release.

In no event shall TI's liability arising out of such information exceed the total purchase price of the TI part(s) at issue in this document sold by TI to Customer on an annual basis.

IMPORTANT NOTICE

Texas Instruments Incorporated and its subsidiaries (TI) reserve the right to make corrections, modifications, enhancements, improvements, and other changes to its products and services at any time and to discontinue any product or service without notice. Customers should obtain the latest relevant information before placing orders and should verify that such information is current and complete. All products are sold subject to TI's terms and conditions of sale supplied at the time of order acknowledgment.

TI warrants performance of its hardware products to the specifications applicable at the time of sale in accordance with TI's standard warranty. Testing and other quality control techniques are used to the extent TI deems necessary to support this warranty. Except where mandated by government requirements, testing of all parameters of each product is not necessarily performed.

TI assumes no liability for applications assistance or customer product design. Customers are responsible for their products and applications using TI components. To minimize the risks associated with customer products and applications, customers should provide adequate design and operating safeguards.

TI does not warrant or represent that any license, either express or implied, is granted under any TI patent right, copyright, mask work right, or other TI intellectual property right relating to any combination, machine, or process in which TI products or services are used. Information published by TI regarding third-party products or services does not constitute a license from TI to use such products or services or a warranty or endorsement thereof. Use of such information may require a license from a third party under the patents or other intellectual property of the third party, or a license from TI under the patents or other intellectual property of TI.

Reproduction of information in TI data books or data sheets is permissible only if reproduction is without alteration and is accompanied by all associated warranties, conditions, limitations, and notices. Reproduction of this information with alteration is an unfair and deceptive business practice. TI is not responsible or liable for such altered documentation.

Resale of TI products or services with statements different from or beyond the parameters stated by TI for that product or service voids all express and any implied warranties for the associated TI product or service and is an unfair and deceptive business practice. TI is not responsible or liable for any such statements.

Following are URLs where you can obtain information on other Texas Instruments products and application solutions:

Products		Applications	
Amplifiers	amplifier.ti.com	Audio	www.ti.com/audio
Data Converters	dataconverter.ti.com	Automotive	www.ti.com/automotive
DSP	dsp.ti.com	Broadband	www.ti.com/broadband
Interface	interface.ti.com	Digital Control	www.ti.com/digitalcontrol
Logic	logic.ti.com	Military	www.ti.com/military
Power Mgmt	power.ti.com	Optical Networking	www.ti.com/opticalnetwork
Microcontrollers	microcontroller.ti.com	Security	www.ti.com/security
		Telephony	www.ti.com/telephony
		Video & Imaging	www.ti.com/video
		Wireless	www.ti.com/wireless

Mailing Address: Texas Instruments
Post Office Box 655303 Dallas, Texas 75265