

SN74HC165-Q1 8-BIT PARALLEL-LOAD SHIFT REGISTER

SCLS518 – AUGUST 2003

- Qualification in Accordance With AEC-Q100†
- Qualified for Automotive Applications
- Customer-Specific Configuration Control Can Be Supported Along With Major-Change Approval
- ESD Protection Exceeds 1500 V Per MIL-STD-883, Method 3015; Exceeds 200 V Using Machine Model (C = 200 pF, R = 0)
- Wide Operating Voltage Range of 2 V to 6 V
- Outputs Can Drive Up To 10 LSTTL Loads
- Low Power Consumption, 80- μ A Max I_{CC}
- Typical $t_{pd} = 13$ ns
- ± 4 -mA Output Drive at 5 V
- Low Input Current of 1 μ A Max
- Complementary Outputs
- Direct Overriding Load (Data) Inputs
- Gated Clock Inputs
- Parallel-to-Serial Data Conversion

† Contact factory for details. Q100 qualification data available on request.

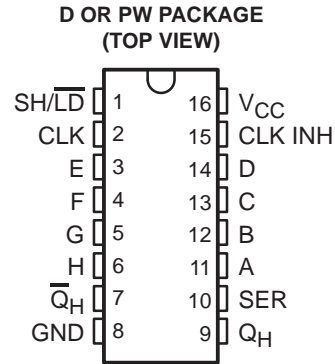

description/ordering information

The SN74HC165 is an 8-bit parallel-load shift register that, when clocked, shift the data toward a serial (Q_H) output. Parallel-in access to each stage is provided by eight individual direct data (A–H) inputs that are enabled by a low level at the shift/load (SH/\overline{LD}) input. The SN74HC165 also features a clock-inhibit (CLK INH) function and a complementary serial (\overline{Q}_H) output.

Clocking is accomplished by a low-to-high transition of the clock (CLK) input while SH/\overline{LD} is held high and CLK INH is held low. The functions of CLK and CLK INH are interchangeable. Since a low CLK and a low-to-high transition of CLK INH also accomplish clocking, CLK INH should be changed to the high level only while CLK is high. Parallel loading is inhibited when SH/\overline{LD} is held high. While SH/\overline{LD} is low, the parallel inputs to the register are enabled independently of the levels of the CLK, CLK INH, or serial (SER) inputs.

ORDERING INFORMATION

T _A	PACKAGE‡		ORDERABLE PART NUMBER	TOP-SIDE MARKING
–40°C to 125°C	SOIC – D	Tape and reel	SN74HC165QDRQ1	HC165Q1
	TSSOP – PW	Tape and reel	SN74HC165QPWRQ1	HC165Q1

‡ Package drawings, standard packing quantities, thermal data, symbolization, and PCB design guidelines are available at www.ti.com/sc/package.



Please be aware that an important notice concerning availability, standard warranty, and use in critical applications of Texas Instruments semiconductor products and disclaimers thereto appears at the end of this data sheet.

PRODUCTION DATA information is current as of publication date. Products conform to specifications per the terms of Texas Instruments standard warranty. Production processing does not necessarily include testing of all parameters.

 **TEXAS
INSTRUMENTS**

POST OFFICE BOX 655303 • DALLAS, TEXAS 75265

Copyright © 2003, Texas Instruments Incorporated

SN74HC165-Q1

8-BIT PARALLEL-LOAD SHIFT REGISTER

SCLS518 – AUGUST 2003

FUNCTION TABLE

INPUTS			FUNCTION
SH/LD	CLK	CLK INH	
L	X	X	Parallel load
H	H	X	No change
H	X	H	No change
H	L	↑	Shift†
H	↑	L	Shift†

† Shift = content of each internal register shifts toward serial output Q_H. Data at SER is shifted into the first register.

logic diagram (positive logic)

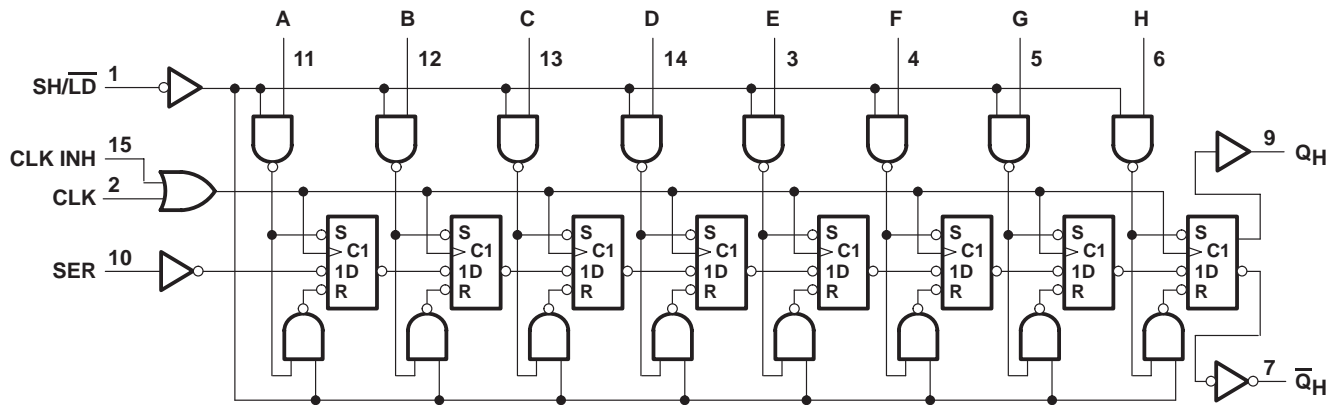

typical shift, load, and inhibit sequence

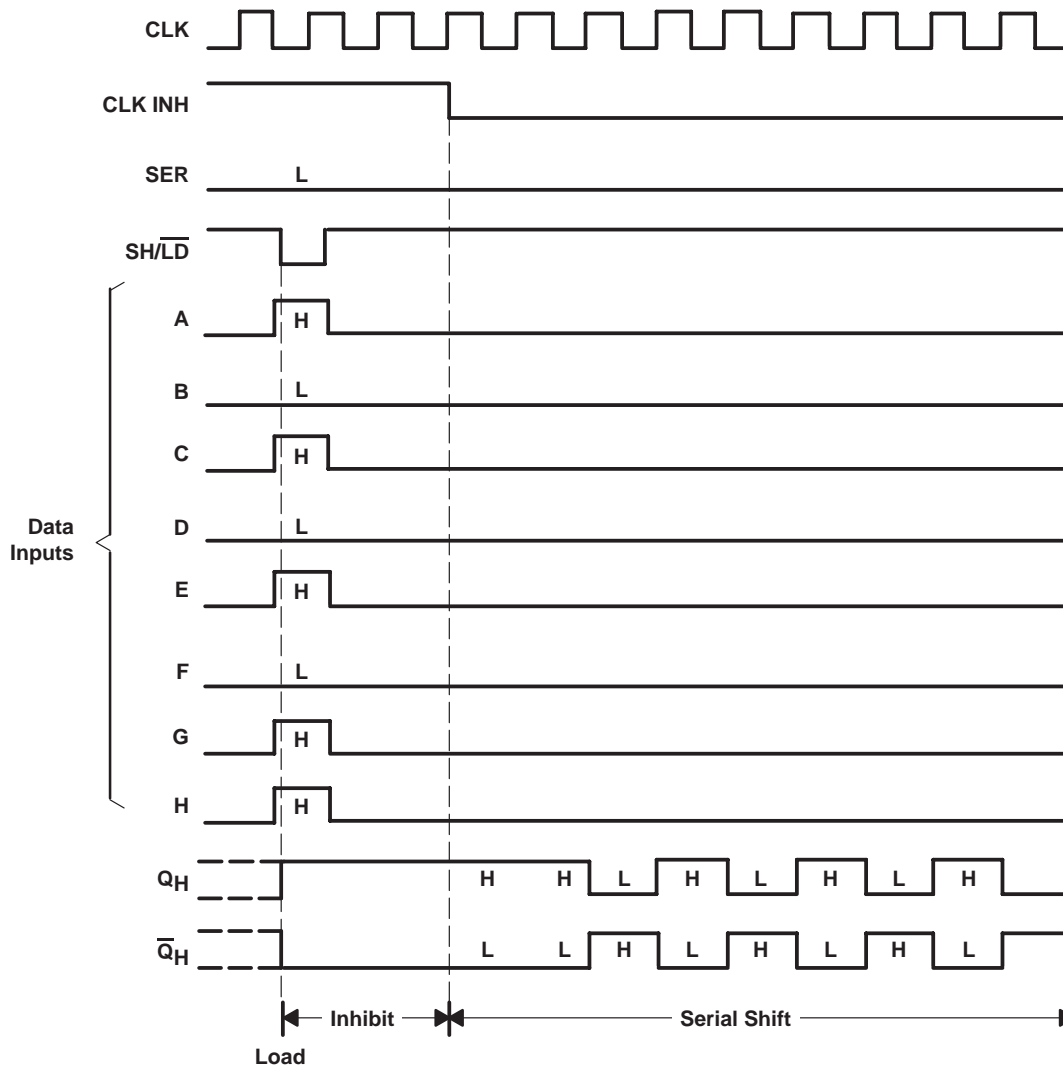

SN74HC165-Q1

8-BIT PARALLEL-LOAD SHIFT REGISTER

SCLS518 – AUGUST 2003

absolute maximum ratings over operating free-air temperature range (unless otherwise noted)[†]

Supply voltage range, V_{CC}	-0.5 V to 7 V
Input clamp current, I_{IK} ($V_I < 0$ or $V_I > V_{CC}$) (see Note 1)	±20 mA
Output clamp current, I_{OK} ($V_O < 0$ or $V_O > V_{CC}$) (see Note 1)	±20 mA
Continuous output current, I_O ($V_O = 0$ to V_{CC})	±25 mA
Continuous current through V_{CC} or GND	±50 mA
Package thermal impedance, θ_{JA} (see Note 2): D package	73°C/W
PW package	108°C/W
Storage temperature range, T_{stg}	-65°C to 150°C

[†] Stresses beyond those listed under “absolute maximum ratings” may cause permanent damage to the device. These are stress ratings only, and functional operation of the device at these or any other conditions beyond those indicated under “recommended operating conditions” is not implied. Exposure to absolute-maximum-rated conditions for extended periods may affect device reliability.

- NOTES: 1. The input and output voltage ratings may be exceeded if the input and output current ratings are observed.
 2. The package thermal impedance is calculated in accordance with JESD 51-7.

recommended operating conditions (see Note 3)

		MIN	NOM	MAX	UNIT
V_{CC}	Supply voltage	2	5	6	V
V_{IH}	High-level input voltage	$V_{CC} = 2\text{ V}$	1.5		V
		$V_{CC} = 4.5\text{ V}$	3.15		
		$V_{CC} = 6\text{ V}$	4.2		
V_{IL}	Low-level input voltage	$V_{CC} = 2\text{ V}$		0.5	V
		$V_{CC} = 4.5\text{ V}$		1.35	
		$V_{CC} = 6\text{ V}$		1.8	
V_I	Input voltage	0		V_{CC}	V
V_O	Output voltage	0		V_{CC}	V
$\Delta t/\Delta v^\ddagger$	Input transition rise/fall time	$V_{CC} = 2\text{ V}$		1000	ns
		$V_{CC} = 4.5\text{ V}$		500	
		$V_{CC} = 6\text{ V}$		400	
T_A	Operating free-air temperature	-40		125	°C

NOTE 3: All unused inputs of the device must be held at V_{CC} or GND to ensure proper device operation. Refer to the TI application report, *Implications of Slow or Floating CMOS Inputs*, literature number SCBA004.

[‡] If this device is used in the threshold region (from $V_{ILmax} = 0.5\text{ V}$ to $V_{IHmin} = 1.5\text{ V}$), there is a potential to go into the wrong state from induced grounding, causing double clocking. Operating with the inputs at $t_t = 1000\text{ ns}$ and $V_{CC} = 2\text{ V}$ does not damage the device; however, functionally, the CLK inputs are not ensured while in the shift, count, or toggle operating modes.



SN74HC165-Q1

8-BIT PARALLEL-LOAD SHIFT REGISTER

SCLS518 – AUGUST 2003

electrical characteristics over recommended operating free-air temperature range (unless otherwise noted)

PARAMETER	TEST CONDITIONS	V _{CC}	T _A = 25°C			MIN	MAX	UNIT
			MIN	TYP	MAX			
V _{OH}	V _I = V _{IH} or V _{IL}	I _{OH} = -20 μA	2 V	1.9	1.998	1.9	V	
			4.5 V	4.4	4.499	4.4		
			6 V	5.9	5.999	5.9		
		I _{OH} = -4 mA	4.5 V	3.98	4.3	3.7		
			6 V	5.48	5.8	5.2		
V _{OL}	V _I = V _{IH} or V _{IL}	I _{OL} = 20 μA	2 V	0.002	0.1	0.1	V	
			4.5 V	0.001	0.1	0.1		
			6 V	0.001	0.1	0.1		
		I _{OL} = 4 mA	4.5 V	0.17	0.26	0.4		
			6 V	0.15	0.26	0.4		
I _I	V _I = V _{CC} or 0	6 V	±0.1	±100	±1000	nA		
I _{CC}	V _I = V _{CC} or 0, I _O = 0	6 V		8	160	μA		
C _i		2 V to 6 V		3	10	10	pF	

SN74HC165-Q1

8-BIT PARALLEL-LOAD SHIFT REGISTER

SCLS518 – AUGUST 2003

timing requirements over recommended operating free-air temperature range (unless otherwise noted)

		V _{CC}	T _A = 25°C		MIN	MAX	UNIT
			MIN	MAX			
f _{clock}	Clock frequency	2 V	6		4.2		MHz
		4.5 V	31		21		
		6 V	36		25		
t _w	SH/ $\overline{\text{LD}}$ low	2 V	80		120		ns
		4.5 V	16		24		
		6 V	14		20		
	CLK high or low	2 V	80		120		
		4.5 V	16		24		
		6 V	14		20		
t _{su}	SH/ $\overline{\text{LD}}$ high before CLK \uparrow	2 V	80		120		ns
		4.5 V	16		24		
		6 V	14		20		
	SER before CLK \uparrow	2 V	40		60		
		4.5 V	8		12		
		6 V	7		10		
	CLK INH low before CLK \uparrow	2 V	100		150		
		4.5 V	20		30		
		6 V	17		25		
	CLK INH high before CLK \uparrow	2 V	40		60		
		4.5 V	8		12		
		6 V	7		10		
	Data before SH/ $\overline{\text{LD}}$ \downarrow	2 V	100		150		
		4.5 V	20		30		
		6 V	17		26		
t _h	SER data after CLK \uparrow	2 V	5		5		ns
		4.5 V	5		5		
		6 V	5		5		
	PAR data after SH/ $\overline{\text{LD}}$ \downarrow	2 V	5		5		
		4.5 V	5		5		
		6 V	5		5		

SN74HC165-Q1

8-BIT PARALLEL-LOAD SHIFT REGISTER

SCLS518 – AUGUST 2003

switching characteristics over recommended operating free-air temperature range, $C_L = 50$ pF (unless otherwise noted) (see Figure 1)

PARAMETER	FROM (INPUT)	TO (OUTPUT)	V _{CC}	T _A = 25°C			MIN	MAX	UNIT
				MIN	TYP	MAX			
f _{max}			2 V	6	13		4.2	MHz	
			4.5 V	31	50		21		
			6 V	36	62		25		
t _{pd}	SH/ \overline{LD}	Q _H or \overline{Q}_H	2 V		80	150		225	ns
			4.5 V		20	30		45	
			6 V		16	26		38	
	CLK	Q _H or \overline{Q}_H	2 V		75	150		225	
			4.5 V		15	30		45	
			6 V		13	26		38	
	H	Q _H or \overline{Q}_H	2 V		75	150		225	
			4.5 V		15	30		45	
			6 V		13	26		38	
t _t		Any	2 V		38	75		110	ns
			4.5 V		8	15		22	
			6 V		6	13		19	

operating characteristics, T_A = 25°C

PARAMETER	TEST CONDITIONS	TYP	UNIT
C _{pd} Power dissipation capacitance	No load	75	pF

SN74HC165-Q1

8-BIT PARALLEL-LOAD SHIFT REGISTER

SCLS518 – AUGUST 2003

PARAMETER MEASUREMENT INFORMATION

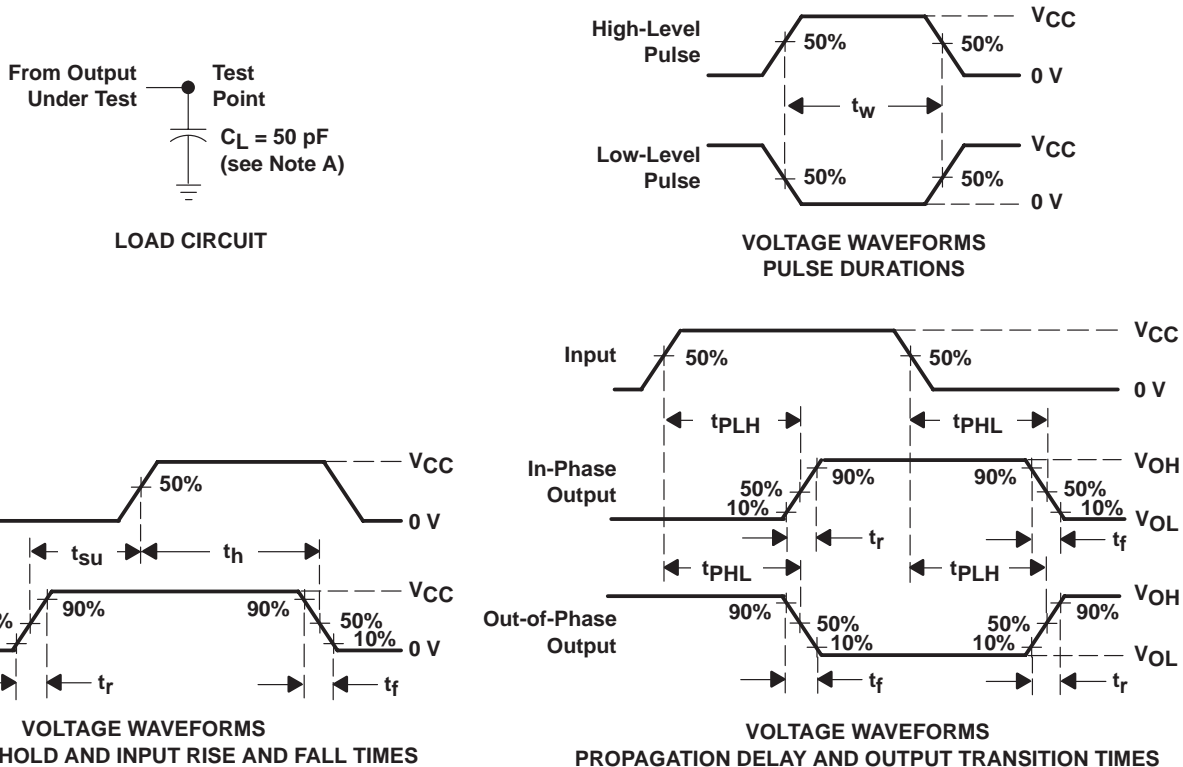

- NOTES:
- A. C_L includes probe and test-fixture capacitance.
 - B. Phase relationships between waveforms were chosen arbitrarily. All input pulses are supplied by generators having the following characteristics: $PRR \leq 1 \text{ MHz}$, $Z_O = 50 \Omega$, $t_r = 6 \text{ ns}$, $t_f = 6 \text{ ns}$.
 - C. For clock inputs, f_{max} is measured when the input duty cycle is 50%.
 - D. The outputs are measured one at a time with one input transition per measurement.
 - E. t_{PLH} and t_{PHL} are the same as t_{pd} .

Figure 1. Load Circuit and Voltage Waveforms

D (R-PDSO-G16)

PLASTIC SMALL-OUTLINE PACKAGE

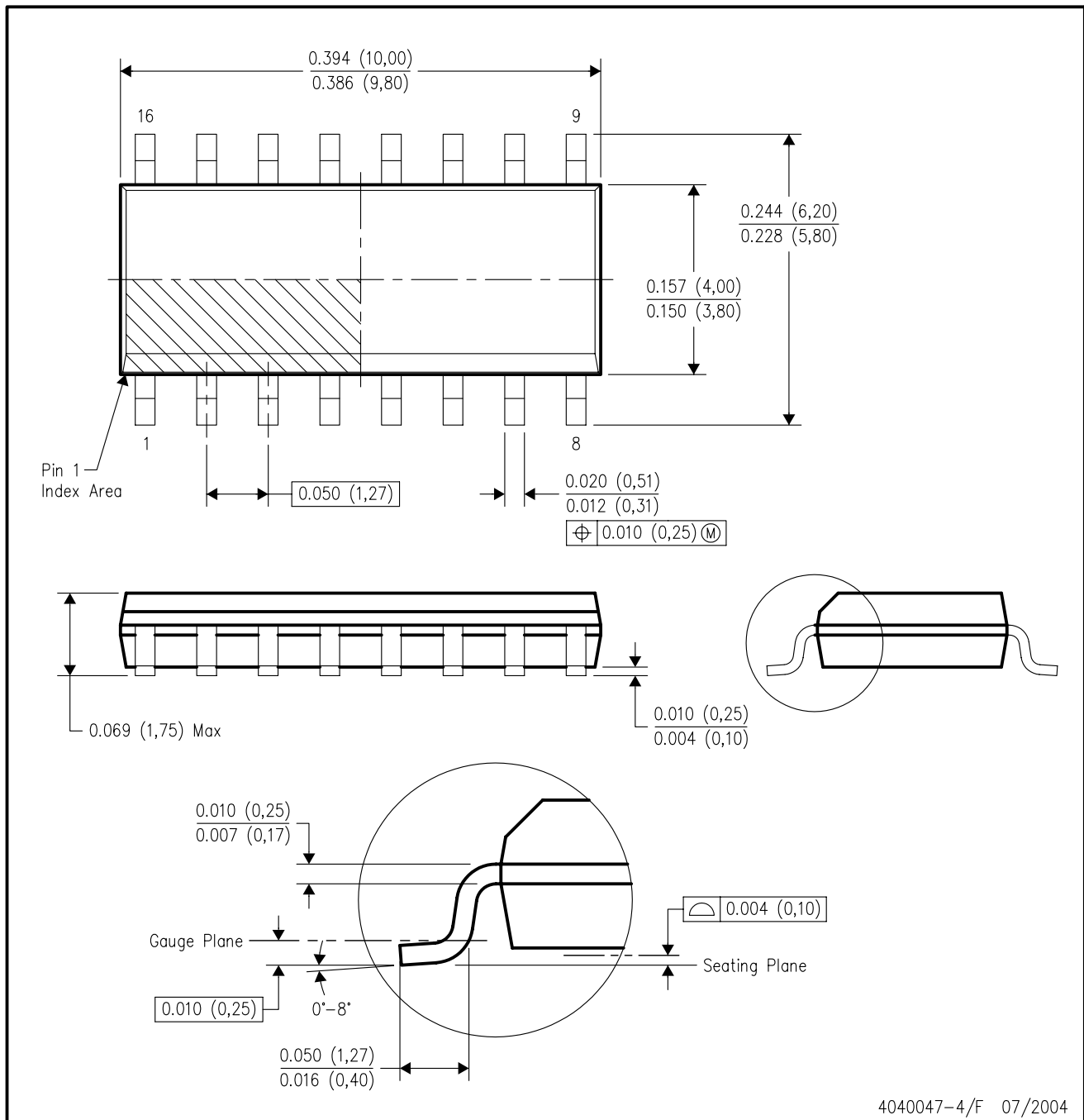

- NOTES:
- A. All linear dimensions are in inches (millimeters).
 - B. This drawing is subject to change without notice.
 - C. Body dimensions do not include mold flash or protrusion not to exceed 0.006 (0,15).
 - D. Falls within JEDEC MS-012 variation AC.

PW (R-PDSO-G**)

PLASTIC SMALL-OUTLINE PACKAGE

14 PINS SHOWN



4040064/F 01/97

- NOTES: A. All linear dimensions are in millimeters.
 B. This drawing is subject to change without notice.
 C. Body dimensions do not include mold flash or protrusion not to exceed 0,15.
 D. Falls within JEDEC MO-153

IMPORTANT NOTICE

Texas Instruments Incorporated and its subsidiaries (TI) reserve the right to make corrections, modifications, enhancements, improvements, and other changes to its products and services at any time and to discontinue any product or service without notice. Customers should obtain the latest relevant information before placing orders and should verify that such information is current and complete. All products are sold subject to TI's terms and conditions of sale supplied at the time of order acknowledgment.

TI warrants performance of its hardware products to the specifications applicable at the time of sale in accordance with TI's standard warranty. Testing and other quality control techniques are used to the extent TI deems necessary to support this warranty. Except where mandated by government requirements, testing of all parameters of each product is not necessarily performed.

TI assumes no liability for applications assistance or customer product design. Customers are responsible for their products and applications using TI components. To minimize the risks associated with customer products and applications, customers should provide adequate design and operating safeguards.

TI does not warrant or represent that any license, either express or implied, is granted under any TI patent right, copyright, mask work right, or other TI intellectual property right relating to any combination, machine, or process in which TI products or services are used. Information published by TI regarding third-party products or services does not constitute a license from TI to use such products or services or a warranty or endorsement thereof. Use of such information may require a license from a third party under the patents or other intellectual property of the third party, or a license from TI under the patents or other intellectual property of TI.

Reproduction of information in TI data books or data sheets is permissible only if reproduction is without alteration and is accompanied by all associated warranties, conditions, limitations, and notices. Reproduction of this information with alteration is an unfair and deceptive business practice. TI is not responsible or liable for such altered documentation.

Resale of TI products or services with statements different from or beyond the parameters stated by TI for that product or service voids all express and any implied warranties for the associated TI product or service and is an unfair and deceptive business practice. TI is not responsible or liable for any such statements.

Following are URLs where you can obtain information on other Texas Instruments products and application solutions:

Products		Applications	
Amplifiers	amplifier.ti.com	Audio	www.ti.com/audio
Data Converters	dataconverter.ti.com	Automotive	www.ti.com/automotive
DSP	dsp.ti.com	Broadband	www.ti.com/broadband
Interface	interface.ti.com	Digital Control	www.ti.com/digitalcontrol
Logic	logic.ti.com	Military	www.ti.com/military
Power Mgmt	power.ti.com	Optical Networking	www.ti.com/opticalnetwork
Microcontrollers	microcontroller.ti.com	Security	www.ti.com/security
		Telephony	www.ti.com/telephony
		Video & Imaging	www.ti.com/video
		Wireless	www.ti.com/wireless

Mailing Address: Texas Instruments
Post Office Box 655303 Dallas, Texas 75265

Copyright © 2004, Texas Instruments Incorporated