

THS4130, THS4131 HIGH-SPEED, LOW NOISE, FULLY-DIFFERENTIAL I/O AMPLIFIERS

SLOS318E – MAY 2000 – REVISED JANUARY 2004

features

- **High Performance**
 - 150 MHz –3 dB Bandwidth ($V_{CC} = \pm 15\text{ V}$)
 - 51 V/ μs Slew Rate
 - –100 dB Third Harmonic Distortion at 250 kHz
- **Low Noise**
 - 1.3 nV/ $\sqrt{\text{Hz}}$ Input-Referred Noise
- **Differential-Input/Differential-Output**
 - Balanced Outputs Reject Common-Mode Noise
 - Reduced Second Harmonic Distortion Due to Differential Output
- **Wide Power Supply Range**
 - $V_{CC} = 5\text{ V}$ Single Supply to $\pm 15\text{ V}$ Dual Supply
- $I_{CC(SD)} = 860\ \mu\text{A}$ in Shutdown Mode (THS4130)

key applications

- Single-Ended To Differential Conversion
- Differential ADC Driver
- Differential Antialiasing
- Differential Transmitter And Receiver
- Output Level Shifter

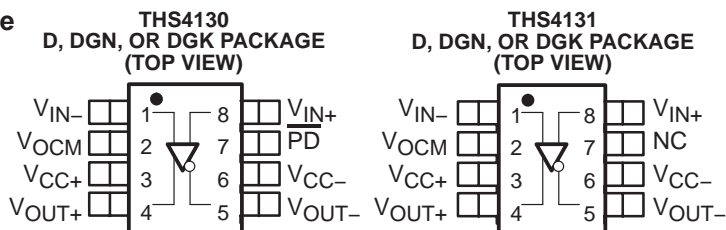

description

The THS413x is one in a family of fully-differential input/differential output devices fabricated using Texas Instruments' state-of-the-art BiComl complementary bipolar process.

The THS413x is made of a true fully-differential signal path from input to output. This design leads to an excellent common-mode noise rejection and improved total harmonic distortion.

HIGH-SPEED DIFFERENTIAL I/O FAMILY

DEVICE	NUMBER OF CHANNELS	SHUTDOWN
THS4130	1	X
THS4131	1	–

RELATED DEVICES

DEVICE	DESCRIPTION
THS412x	100 MHz, 43 V/ μs , 3.7 nV/ $\sqrt{\text{Hz}}$
THS414x	160 MHz, 450 V/ μs , 6.5 nV/ $\sqrt{\text{Hz}}$
THS415x	180 MHz, 850 V/ μs , 9 nV/ $\sqrt{\text{Hz}}$

typical A/D application circuit

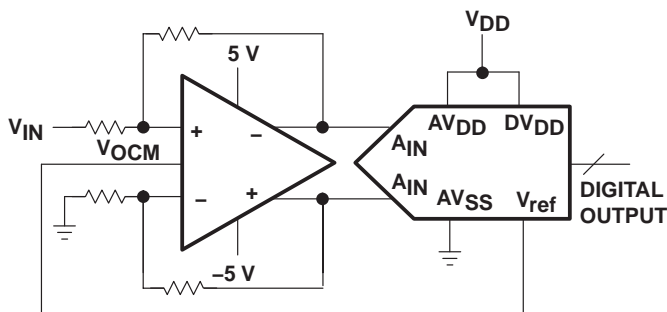

TOTAL HARMONIC DISTORTION VS FREQUENCY

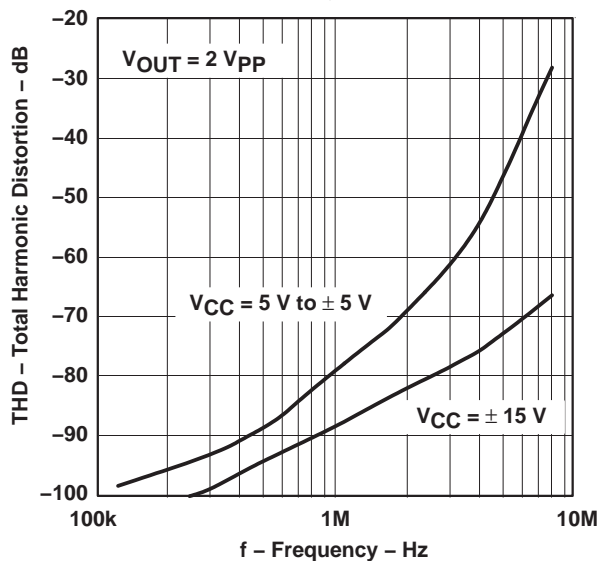

Please be aware that an important notice concerning availability, standard warranty, and use in critical applications of Texas Instruments semiconductor products and disclaimers thereto appears at the end of this data sheet.

PRODUCTION DATA information is current as of publication date. Products conform to specifications per the terms of Texas Instruments standard warranty. Production processing does not necessarily include testing of all parameters.

**TEXAS
INSTRUMENTS**

POST OFFICE BOX 655303 • DALLAS, TEXAS 75265

Copyright © 2001 – 2004, Texas Instruments Incorporated

THS4130, THS4131 HIGH-SPEED, LOW NOISE, FULLY-DIFFERENTIAL I/O AMPLIFIERS

SLOS318E – MAY 2000 – REVISED JANUARY 2004

AVAILABLE OPTIONS

T _A	PACKAGED DEVICES					EVALUATION MODULES
	SMALL OUTLINE (D)	MSOP PowerPAD™		MSOP		
		(DGN)	SYMBOL	(DGK)	SYMBOL	
0°C to 70°C	THS4130CD	THS4130CDGN	AOB	THS4130CDGK	ATP	THS4130EVM
	THS4131CD	THS4131CDGN	AOD	THS4131CDGK	ATQ	THS4131EVM
-40°C to 85°C	THS4130ID	THS4130IDGN	AOC	THS4130IDGK	ASO	-
	THS4131ID	THS4131IDGN	AOE	THS4131IDGK	ASP	-

absolute maximum ratings over operating free-air temperature range (unless otherwise noted)†

Supply voltage, V _{CC-} to V _{CC+}	±33 V
Input voltage, V _I	±V _{CC}
Output current, I _O (see Note 1)	150 mA
Differential input voltage, V _{ID}	±6 V
Continuous total power dissipation	See Dissipation Rating Table
Maximum junction temperature, T _J (see Note 2)	150°C
Maximum junction temperature, continuous operation, long term reliability, T _J (see Note 3)	125°C
Operating free-air temperature, T _A :C suffix	0°C to 70°C
I suffix	-40°C to 85°C
Storage temperature, T _{stg}	-65°C to 150°C
Lead temperature 1,6 mm (1/16 Inch) from case for 10 seconds	300°C
ESD ratings:	
HBM	2500 V
CDM	1500 V
MM	200 V

† Stresses beyond those listed under “absolute maximum ratings” may cause permanent damage to the device. These are stress ratings only, and functional operation of the device at these or any other conditions beyond those indicated under “recommended operating conditions” is not implied. Exposure to absolute-maximum-rated conditions for extended periods may affect device reliability.

NOTE 1: The THS413x may incorporate a PowerPad™ on the underside of the chip. This acts as a heatsink and must be connected to a thermally dissipative plane for proper power dissipation. Failure to do so may result in exceeding the maximum junction temperature which could permanently damage the device. See TI technical brief SLMA002 and SLMA004 for more information about utilizing the PowerPad™ thermally enhanced package.

NOTE 2: The absolute maximum temperature under any condition is limited by the constraints of the silicon process.

NOTE 3: The maximum junction temperature for continuous operation is limited by package constraints. Operation above this temperature may result in reduced reliability and/or lifetime of the device.

DISSIPATION RATING TABLE

PACKAGE	θ _{JA} ‡ (°C/W)	θ _{JC} (°C/W)	POWER RATINGS§	
			T _A = 25°C	T _A = 85°C
D	97.5	38.3	1.02 W	410 mW
DGN	58.4	4.7	1.71 W	685 mW
DGK	260	54.2	385 mW	154 mW

‡ This data was taken using the JEDEC standard High-K test PCB.

§ Power rating is determined with a junction temperature of 125°C. This is the point where distortion starts to substantially increase. Thermal management of the final PCB should strive to keep the junction temperature at or below 125°C for best performance and long term reliability.

recommended operating conditions

		MIN	TYP	MAX	UNIT
Supply voltage, V _{CC+} to V _{CC-}	Dual supply	±2.5		±15	V
	Single supply	5		30	
Operating free-air temperature, T _A	C suffix	0		70	°C
	I suffix	-40		85	

PowerPAD is a trademark of Texas Instruments.



THS4130, THS4131

HIGH-SPEED, LOW NOISE, FULLY-DIFFERENTIAL I/O AMPLIFIERS

SLOS318E – MAY 2000 – REVISED JANUARY 2004

electrical characteristics, $V_{CC} = \pm 5\text{ V}$, $R_L = 800\ \Omega$, $T_A = 25^\circ\text{C}$ (unless otherwise noted)†

dynamic performance

PARAMETER		TEST CONDITIONS		MIN	TYP	MAX	UNIT
BW	Small signal bandwidth (–3 dB), Single ended input, differential output, $V_I = 63\text{ mV}_{PP}$	$V_{CC} = 5$	Gain = 1, $R_f = 390\ \Omega$		125		MHz
		$V_{CC} = \pm 5$	Gain = 1, $R_f = 390\ \Omega$		135		
		$V_{CC} = \pm 15$	Gain = 1, $R_f = 390\ \Omega$		150		
	Small signal bandwidth (–3 dB), Single ended input, differential output, $V_I = 63\text{ mV}_{PP}$	$V_{CC} = 5$	Gain = 2, $R_f = 750\ \Omega$		80		
		$V_{CC} = \pm 5$	Gain = 2, $R_f = 750\ \Omega$		85		
		$V_{CC} = \pm 15$	Gain = 2, $R_f = 750\ \Omega$		90		
SR	Slew rate (see Note 2)	Gain = 1			52		V/ μs
t_s	Settling time to 0.1%	Step voltage = 2 V, Gain = 1			78		ns
	Settling time to 0.01%				213		ns

† The full range temperature is 0°C to 70°C for the C suffix, and -40°C to 85°C for the I suffix.

NOTE 4: Slew rate is measured from an output level range of 25% to 75%.

distortion performance

PARAMETER		TEST CONDITIONS		MIN	TYP	MAX	UNIT
THD	Total harmonic distortion, Differential input, differential output, Gain = 1, $R_f = 390\ \Omega$, $R_L = 800\ \Omega$, $V_O = 2\text{ V}_{PP}$	$V_{CC} = 5$	$f = 250\text{ kHz}$		–95		dBc
			$f = 1\text{ MHz}$		–81		
		$V_{CC} = \pm 5$	$f = 250\text{ kHz}$		–96		
			$f = 1\text{ MHz}$		–80		
		$V_{CC} = \pm 15$	$f = 250\text{ kHz}$		–97		
			$f = 1\text{ MHz}$		–80		
	$V_O = 4\text{ V}_{PP}$	$V_{CC} = \pm 5$	$f = 250\text{ kHz}$		–91		
			$f = 1\text{ MHz}$		–75		
Spurious free dynamic range (SFDR), Differential input, differential output, Gain = 1, $R_f = 390\ \Omega$, $R_L = 800\ \Omega$, $f = 250\text{ kHz}$	$V_O = 2\text{ V}_{pp}$	$V_{CC} = \pm 2.5$		97		dB	
		$V_{CC} = \pm 5$		98			
	$V_O = 4\text{ V}_{pp}$	$V_{CC} = \pm 5$		99			
		$V_{CC} = \pm 15$		93			
Third intermodulation distortion	$V_I(PP) = 4\text{ V}$, $F1 = 3\text{ MHz}$, $F2 = 3.5\text{ MHz}$	G = 1,			–53		dBc
Third order intercept	$V_I(PP) = 4\text{ V}$, $F1 = 3\text{ MHz}$, $F2 = 3.5\text{ MHz}$	G = 1,			41.5		dB

† The full range temperature is 0°C to 70°C for the C suffix, and -40°C to 85°C for the I suffix.



THS4130, THS4131 HIGH-SPEED, LOW NOISE, FULLY-DIFFERENTIAL I/O AMPLIFIERS

SLOS318E – MAY 2000 – REVISED JANUARY 2004

electrical characteristics, $V_{CC} = \pm 5\text{ V}$, $R_L = 800\ \Omega$, $T_A = 25^\circ\text{C}$ (unless otherwise noted) (continued)[†]

noise performance

PARAMETER		TEST CONDITIONS	MIN	TYP	MAX	UNIT
V_n	Input voltage noise	$f = 10\text{ kHz}$		1.3		$\text{nV}/\sqrt{\text{Hz}}$
I_n	Input current noise	$f = 10\text{ kHz}$		1		$\text{pA}/\sqrt{\text{Hz}}$

[†] The full range temperature is 0°C to 70°C for the C suffix, and -40°C to 85°C for the I suffix.

dc performance

PARAMETER		TEST CONDITIONS	MIN	TYP	MAX	UNIT
Open loop gain		$T_A = 25^\circ\text{C}$	71	78		dB
		$T_A = \text{full range}$	69			
$V_{(OS)}$	Input offset voltage	$T_A = 25^\circ\text{C}$		0.2	2	mV
		$T_A = \text{full range}$			3	
	Common mode input offset voltage, referred to V_{OCM}	$T_A = 25^\circ\text{C}$		0.2	3.5	
	Input offset voltage drift	$T_A = \text{full range}$		4.5		$\mu\text{V}/^\circ\text{C}$
I_{IB}	Input bias current	$T_A = \text{full range}$		2	6	μA
I_{OS}	Input offset current	$T_A = \text{full range}$		100	500	nA
	Offset drift			2		$\text{nA}/^\circ\text{C}$

[†] The full range temperature is 0°C to 70°C for the C suffix, and -40°C to 85°C for the I suffix.

input characteristics

PARAMETER		TEST CONDITIONS	MIN	TYP	MAX	UNIT
CMRR	Common-mode rejection ratio	$T_A = \text{full range}$	80	95		dB
V_{ICR}	Common-mode input voltage range		-3.77 to 4.3	-4 to 4.5		V
R_I	Input resistance	Measured into each input terminal		34		$\text{M}\Omega$
C_I	Input capacitance, closed loop			4		pF
r_o	Output resistance	Open loop		41		Ω

[†] The full range temperature is 0°C to 70°C for the C suffix, and -40°C to 85°C for the I suffix.

output characteristics

PARAMETER		TEST CONDITIONS	MIN	TYP	MAX	UNIT
Output voltage swing		$V_{CC} = 5\text{ V}$	$T_A = 25^\circ\text{C}$	1.2 to 3.8	0.9 to 4.1	V
			$T_A = \text{full range}$	1.3 to 3.7		
		$V_{CC} = \pm 5\text{ V}$	$T_A = 25^\circ\text{C}$	± 3.7	± 4	
			$T_A = \text{full range}$	± 3.6		
		$V_{CC} = \pm 15\text{ V}$	$T_A = 25^\circ\text{C}$	± 10.5	± 12.4	
			$T_A = \text{full range}$	± 10.2		
I_O Output current		$V_{CC} = 5\text{ V}$, $R_L = 7\ \Omega$	$T_A = 25^\circ\text{C}$	25	45	mA
			$T_A = \text{full range}$	20		
		$V_{CC} = \pm 5\text{ V}$, $R_L = 7\ \Omega$	$T_A = 25^\circ\text{C}$	30	55	
			$T_A = \text{full range}$	28		
		$V_{CC} = \pm 15\text{ V}$, $R_L = 7\ \Omega$	$T_A = 25^\circ\text{C}$	60	85	
			$T_A = \text{full range}$	50		

[†] The full range temperature is 0°C to 70°C for the C suffix, and -40°C to 85°C for the I suffix.



THS4130, THS4131

HIGH-SPEED, LOW NOISE, FULLY-DIFFERENTIAL I/O AMPLIFIERS

SLOS318E – MAY 2000 – REVISED JANUARY 2004

electrical characteristics, $V_{CC} = \pm 5\text{ V}$, $R_L = 800\ \Omega$, $T_A = 25^\circ\text{C}$ (unless otherwise noted) (continued)†

power supply

PARAMETER		TEST CONDITIONS		MIN	TYP	MAX	UNIT
V_{CC}	Supply voltage range	Single supply		4		33	V
		Split supply		± 2		± 16.5	
I_{CC}	Quiescent current	$V_{CC} = \pm 5\text{ V}$	$T_A = 25^\circ\text{C}$	12.3		15	mA
			$T_A = \text{full range}$			16	
		$V_{CC} = \pm 15\text{ V}$	$T_A = 25^\circ\text{C}$	14			
$I_{CC(SD)}$	Quiescent current (shutdown) (THS4130 only)	$\overline{V_{PD}} = -5\text{ V}$	$T_A = 25^\circ\text{C}$	0.86		1.4	mA
			$T_A = \text{full range}$			1.5	
PSRR	Power supply rejection ratio (dc)			73	98		dB
				70			

† The full range temperature is 0°C to 70°C for the C suffix, and -40°C to 85°C for the I suffix.

TYPICAL CHARACTERISTICS

Table of Graphs

			FIGURE
	Small signal frequency response		1, 2
	Small signal frequency response (various supplies)		3
	Small signal frequency response (various C_F)		4
	Small signal frequency response (various C_L)		5
	Large signal transient response (differential in/single out)		6
	Large signal frequency response		7
CMMR	Common mode rejection ratio	vs Frequency	8
I_{CC}	Supply current	vs Free-air temperature	9
		vs Free-air temperature (shutdown state)	10
I_{IB}	Input bias current	vs Free-air temperature	11
	Settling time		12
PSRR	Power supply rejection ratio	vs Frequency (differential out)	13
	Large signal transient response		14
THD	Total harmonic distortion	vs Frequency	15
	Second harmonic distortion	vs Frequency	16, 17
		vs Output voltage	18, 19
	Third harmonic distortion	vs Frequency	20, 21
		vs Output voltage	22, 23
V_n	Voltage noise	vs Frequency	24
I_n	Current noise	vs Frequency	25
$V_{(OS)}$	Input offset voltage	vs Common-mode output voltage	26
V_O	Output voltage	vs Differential load resistance	27
z_O	Output impedance	vs Frequency	28



THS4130, THS4131 HIGH-SPEED, LOW NOISE, FULLY-DIFFERENTIAL I/O AMPLIFIERS

SLOS318E – MAY 2000 – REVISED JANUARY 2004

TYPICAL CHARACTERISTICS

SMALL SIGNAL FREQUENCY RESPONSE

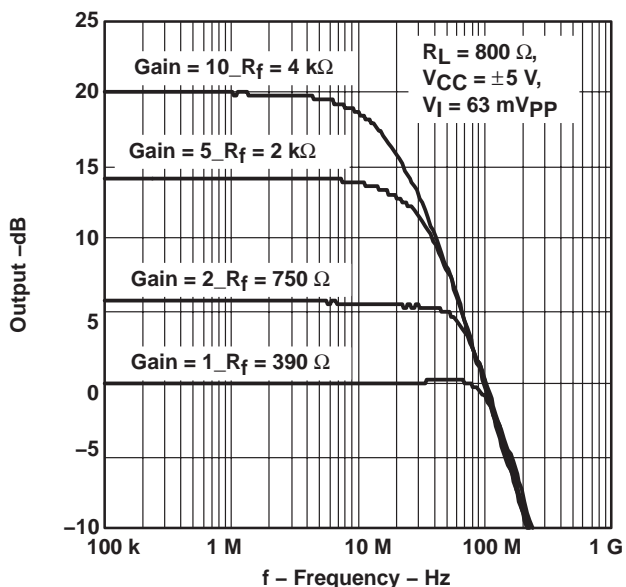

Figure 1

SMALL SIGNAL FREQUENCY RESPONSE

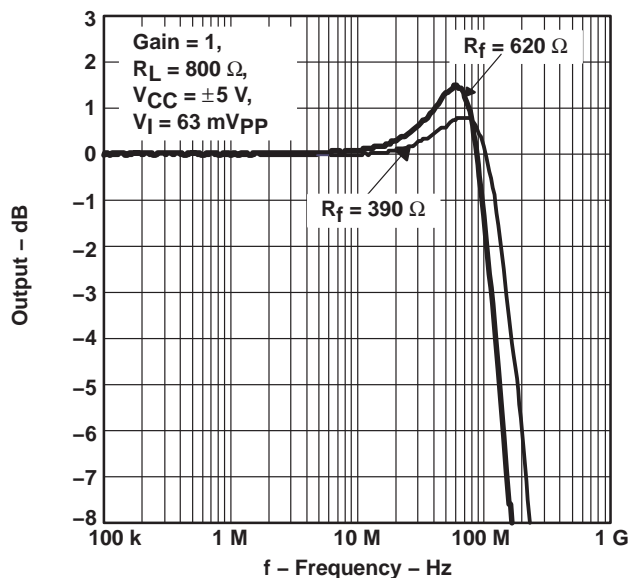

Figure 2

SMALL SIGNAL FREQUENCY RESPONSE
(VARIOUS SUPPLIES)

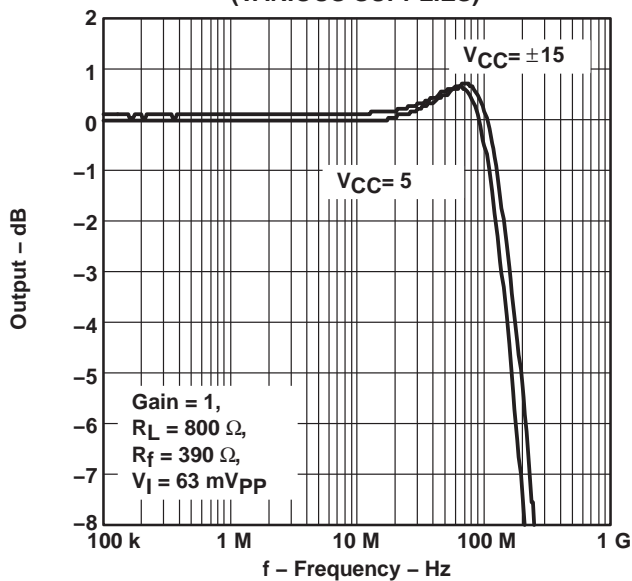

Figure 3

SMALL SIGNAL FREQUENCY RESPONSE
(VARIOUS C_F)

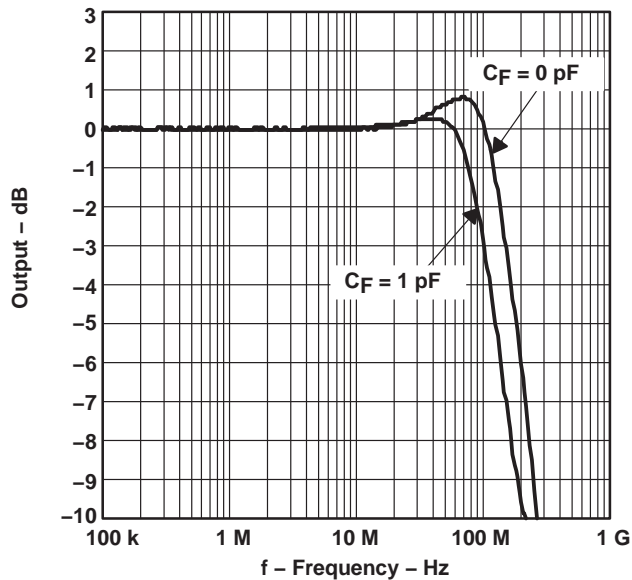

Figure 4

TYPICAL CHARACTERISTICS

SMALL SIGNAL FREQUENCY RESPONSE
(VARIOUS C_L)

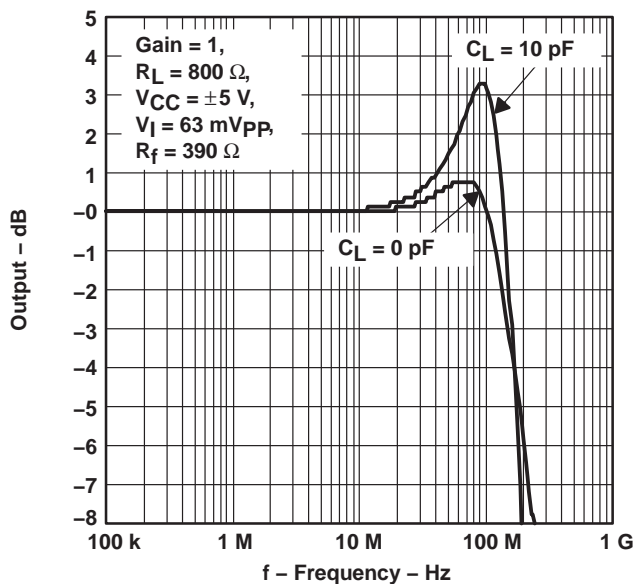

Figure 5

LARGE SIGNAL TRANSIENT RESPONSE
(DIFFERENTIAL IN/SINGLE OUT)

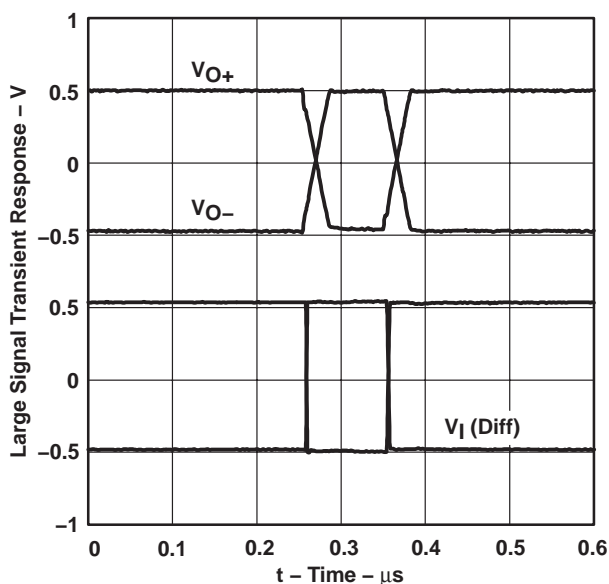

Figure 6

LARGE SIGNAL FREQUENCY RESPONSE

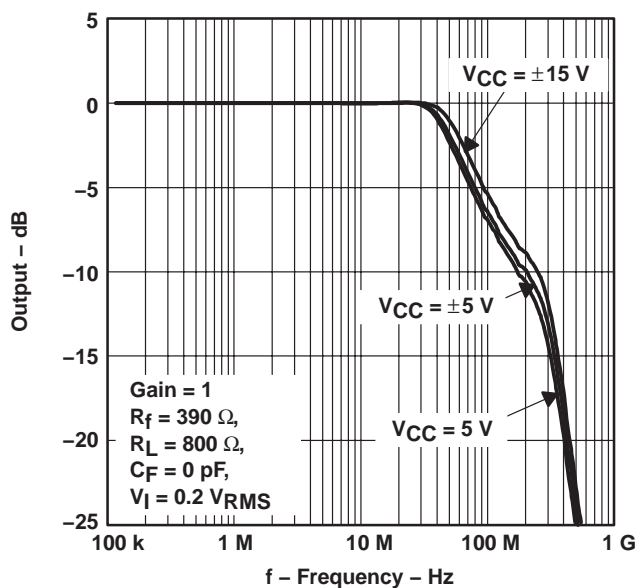

Figure 7

COMMON MODE REJECTION RATIO
VS
FREQUENCY

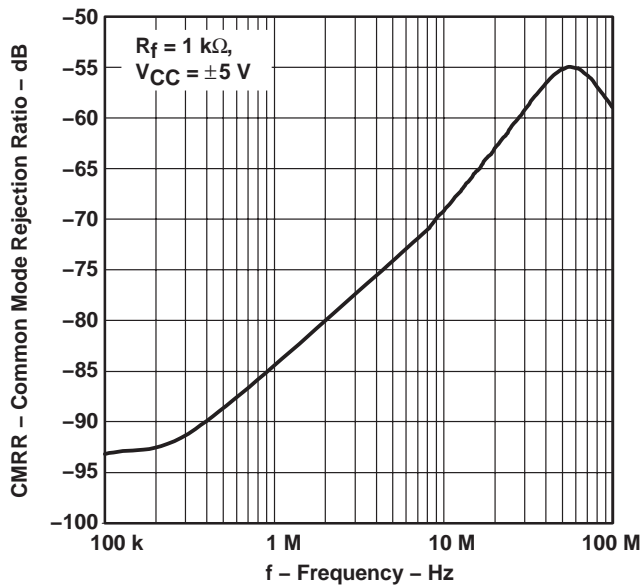

Figure 8

THS4130, THS4131 HIGH-SPEED, LOW NOISE, FULLY-DIFFERENTIAL I/O AMPLIFIERS

SLOS318E – MAY 2000 – REVISED JANUARY 2004

TYPICAL CHARACTERISTICS

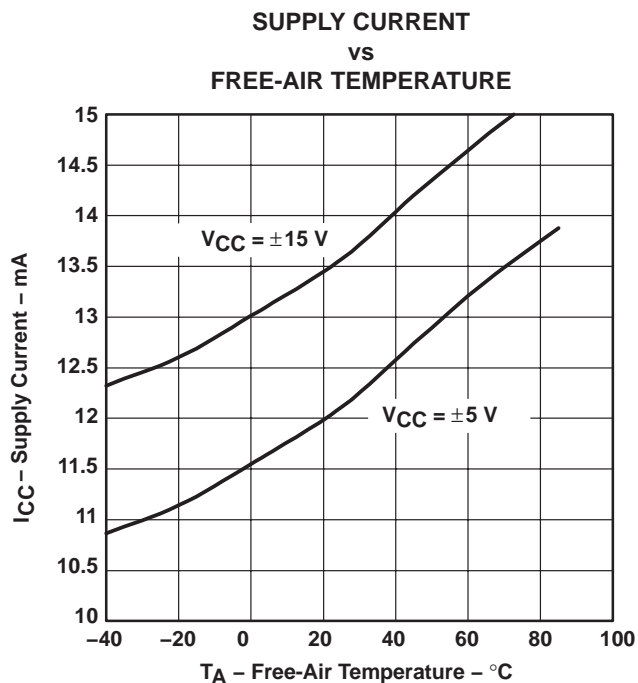

Figure 9

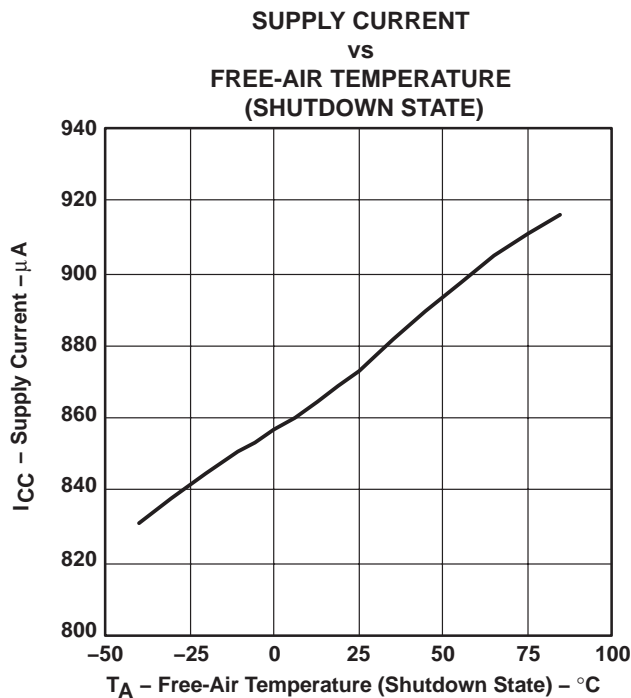

Figure 10

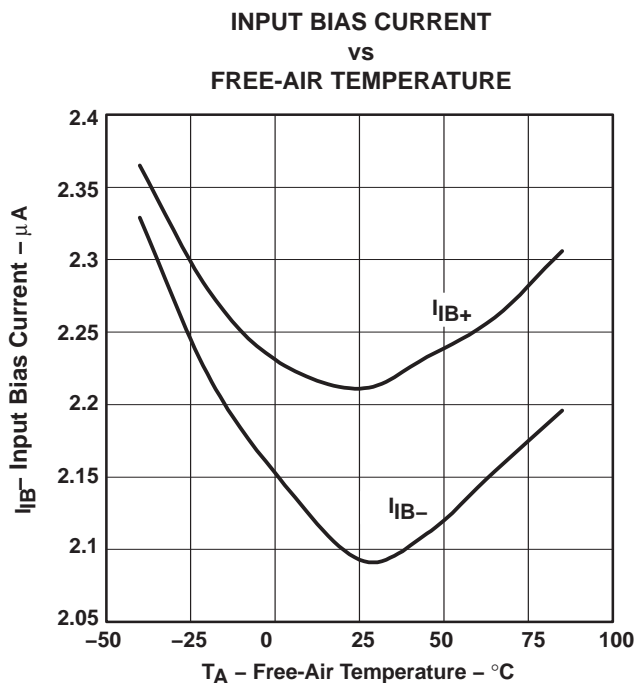

Figure 11

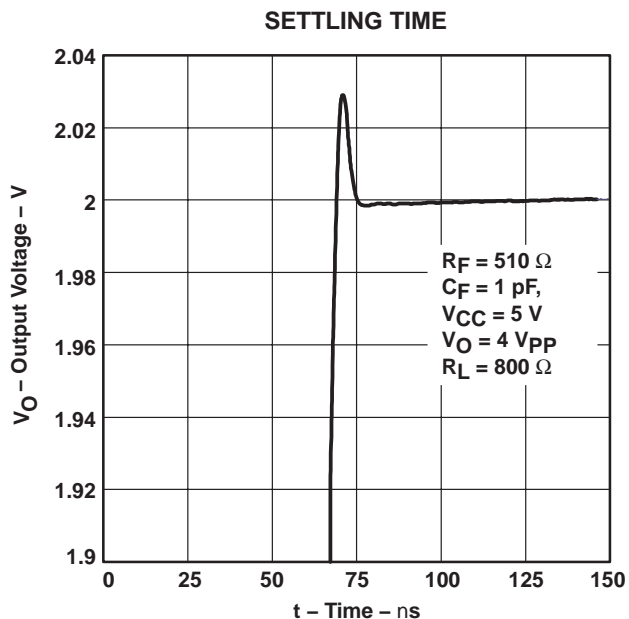

Figure 12



TYPICAL CHARACTERISTICS

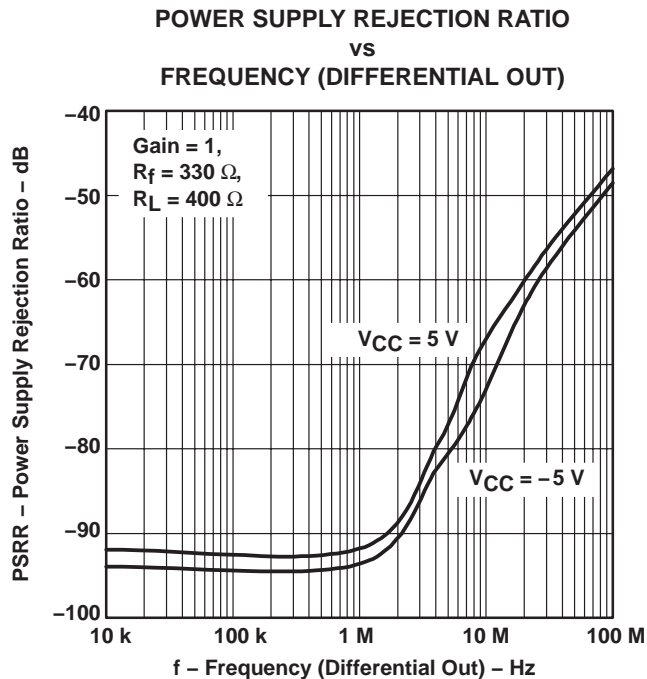

Figure 13

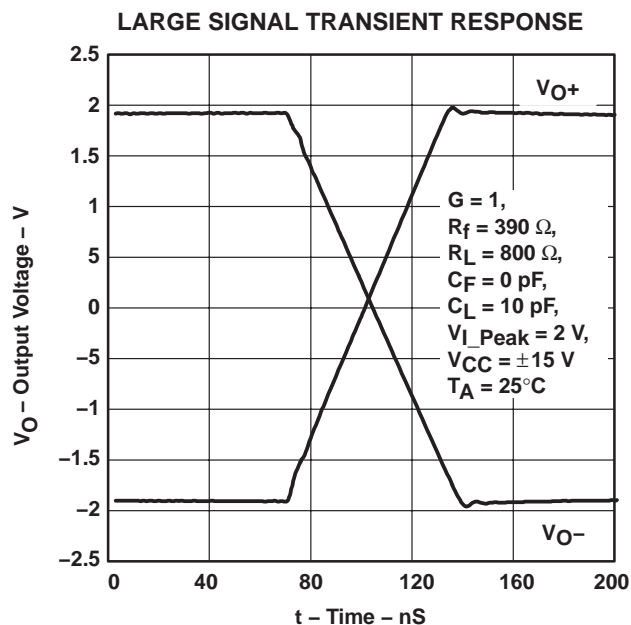

Figure 14

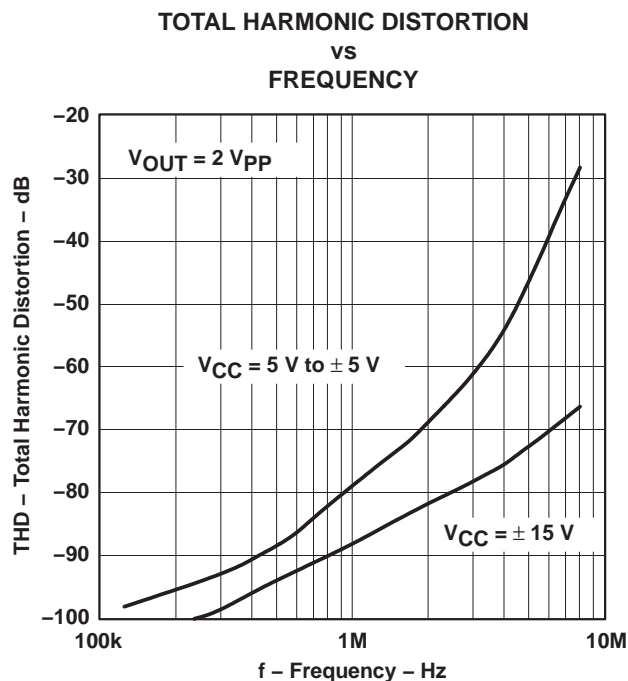

Figure 15

THS4130, THS4131 HIGH-SPEED, LOW NOISE, FULLY-DIFFERENTIAL I/O AMPLIFIERS

SLOS318E – MAY 2000 – REVISED JANUARY 2004

TYPICAL CHARACTERISTICS

SECOND HARMONIC DISTORTION
vs
FREQUENCY

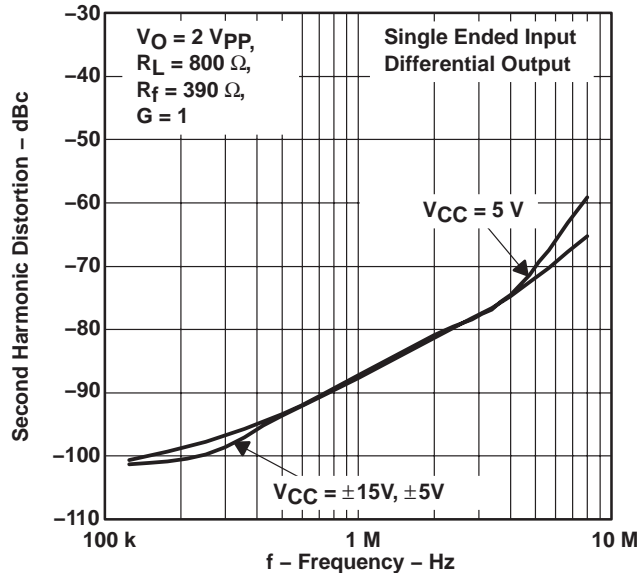

Figure 16

SECOND HARMONIC DISTORTION
vs
FREQUENCY

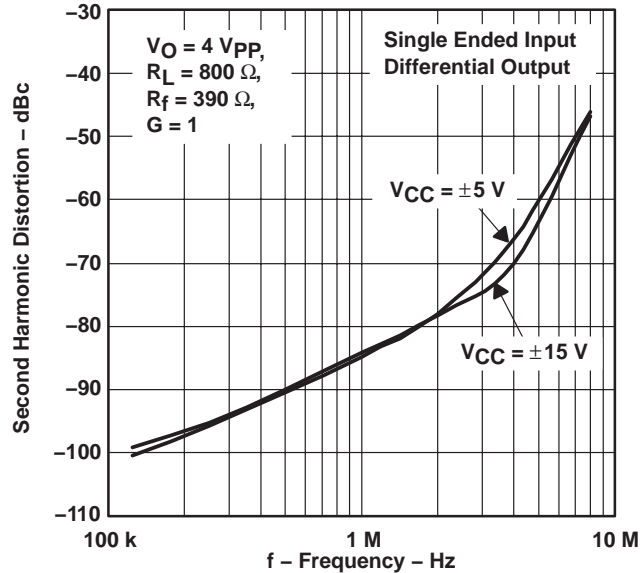

Figure 17

SECOND HARMONIC DISTORTION
vs
OUTPUT VOLTAGE

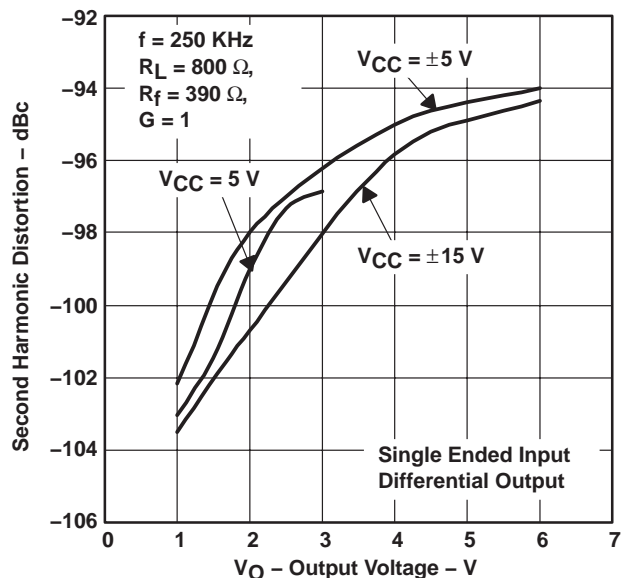

Figure 18

SECOND HARMONIC DISTORTION
vs
OUTPUT VOLTAGE

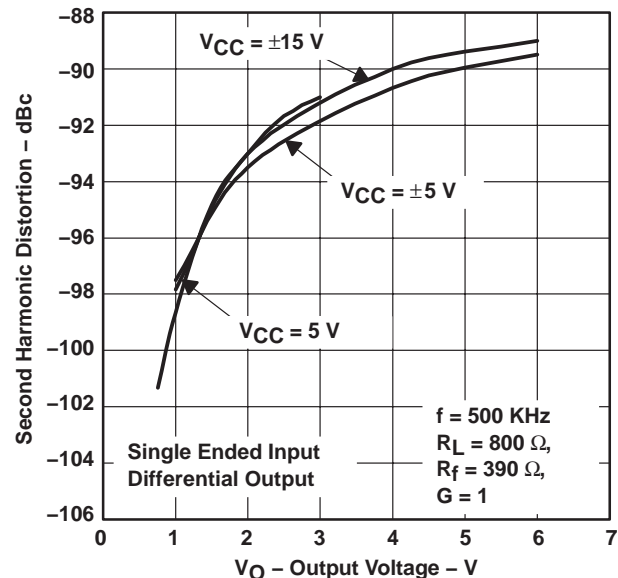

Figure 19

TYPICAL CHARACTERISTICS

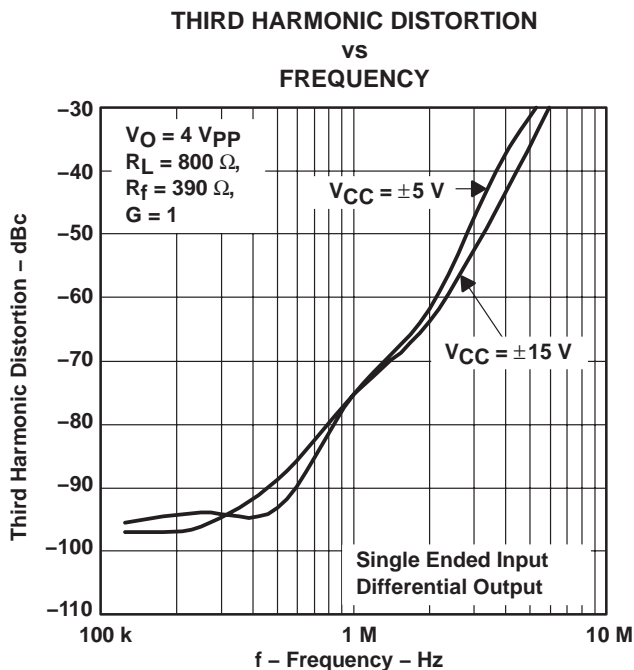

Figure 20

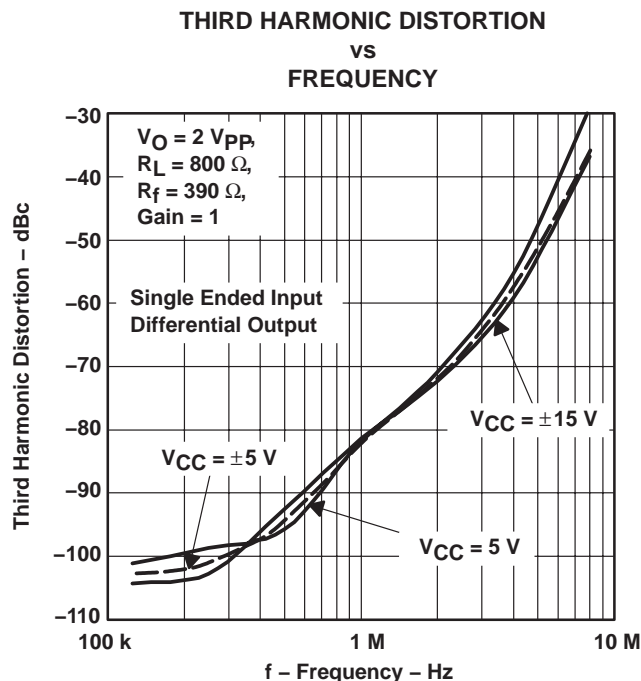

Figure 21

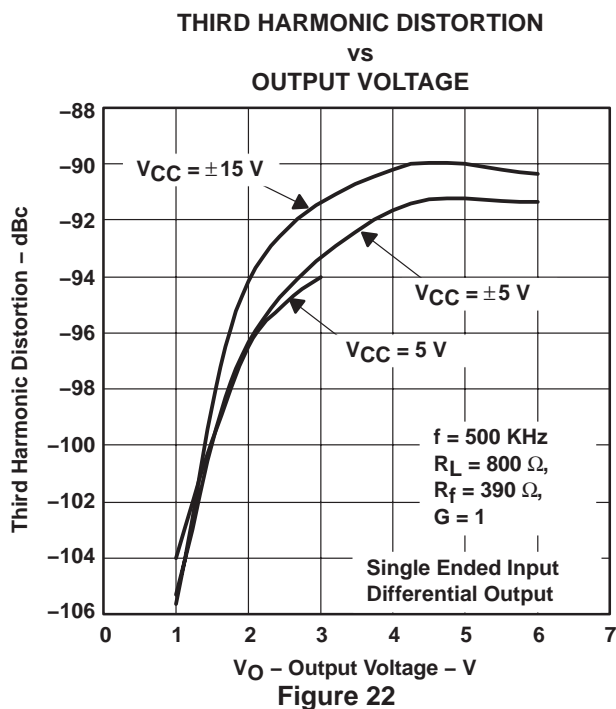

Figure 22

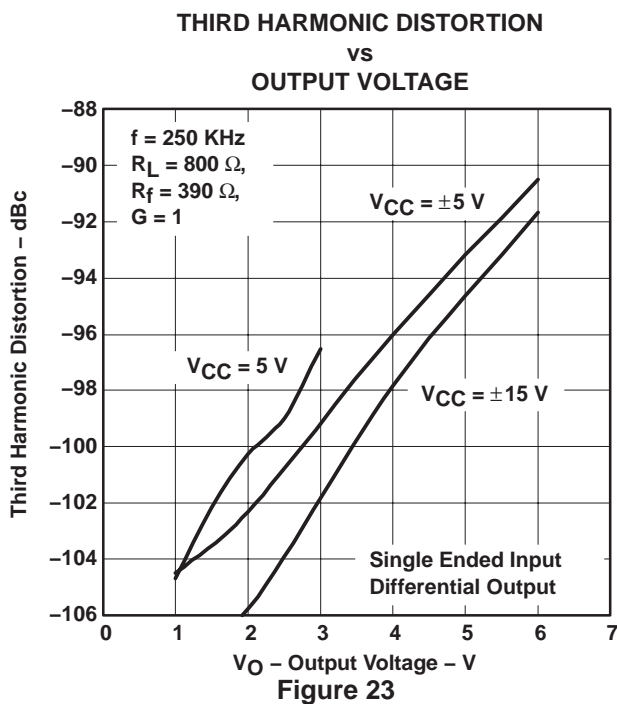
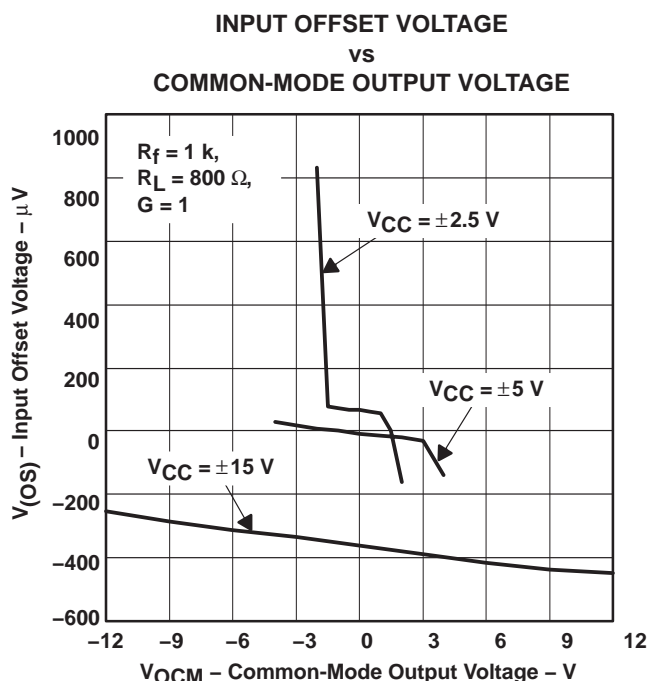
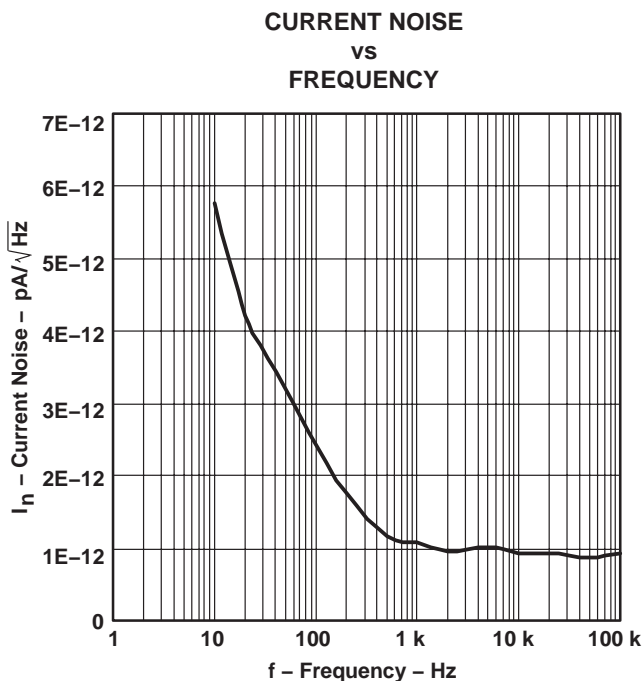
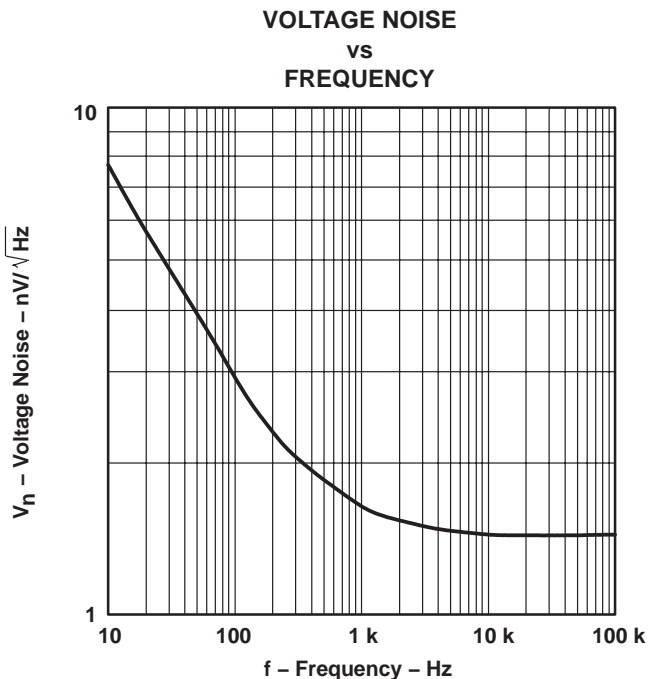

Figure 23

THS4130, THS4131 HIGH-SPEED, LOW NOISE, FULLY-DIFFERENTIAL I/O AMPLIFIERS

SLOS318E – MAY 2000 – REVISED JANUARY 2004

TYPICAL CHARACTERISTICS



THS4130, THS4131
HIGH-SPEED, LOW NOISE, FULLY-DIFFERENTIAL I/O AMPLIFIERS

SLOS318E – MAY 2000 – REVISED JANUARY 2004

TYPICAL CHARACTERISTICS

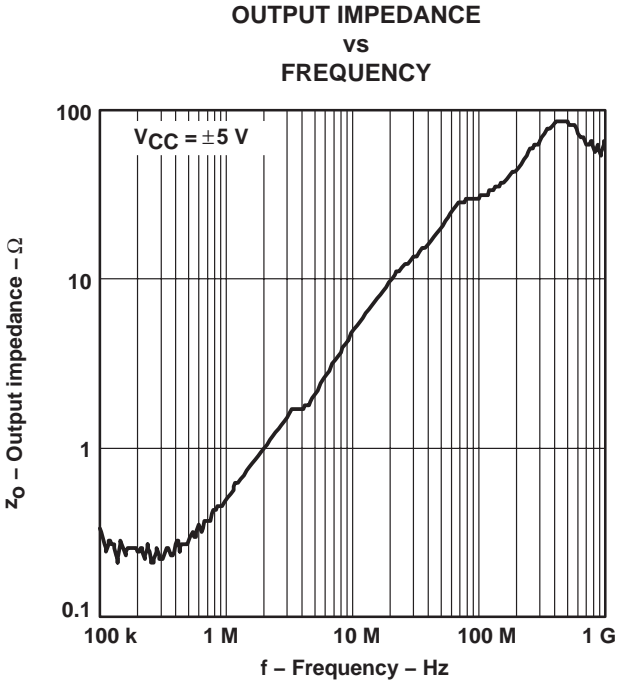
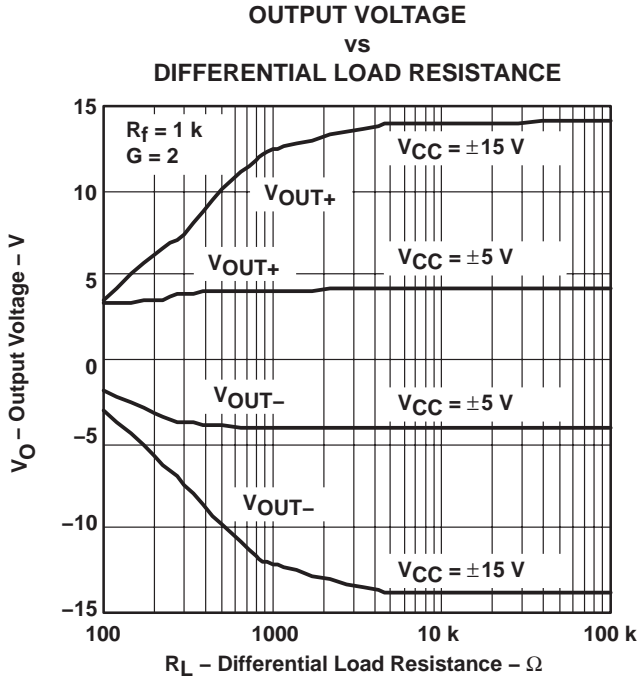

THS4130, THS4131 HIGH-SPEED, LOW NOISE, FULLY-DIFFERENTIAL I/O AMPLIFIERS

SLOS318E – MAY 2000 – REVISED JANUARY 2004

APPLICATION INFORMATION

resistor matching

Resistor matching is important in fully differential amplifiers. The balance of the output on the reference voltage depends on matched ratios of the resistor. CMRR, PSRR, and cancellation of the second harmonic distortion will diminish if resistor mismatch occurs. Therefore, it is recommended to use 1% tolerance resistors or better to keep the performance optimized.

V_{OCM} sets the dc level of the output signals. If no voltage is applied to the V_{OCM} pin, it will be set to the midrail voltage internally defined as:

$$\frac{(V_{CC+}) + (V_{CC-})}{2}$$

In the differential mode, the V_{OCM} on the two outputs cancel each other. Therefore, the output in the differential mode is the same as the input in the gain of 1. V_{OCM} has a high bandwidth capability up to the typical operation range of the amplifier. For the prevention of noise going through the device, use a 0.1 μF capacitor on the V_{OCM} pin as a bypass capacitor. The following graph shows the simplified diagram of the THS413x.

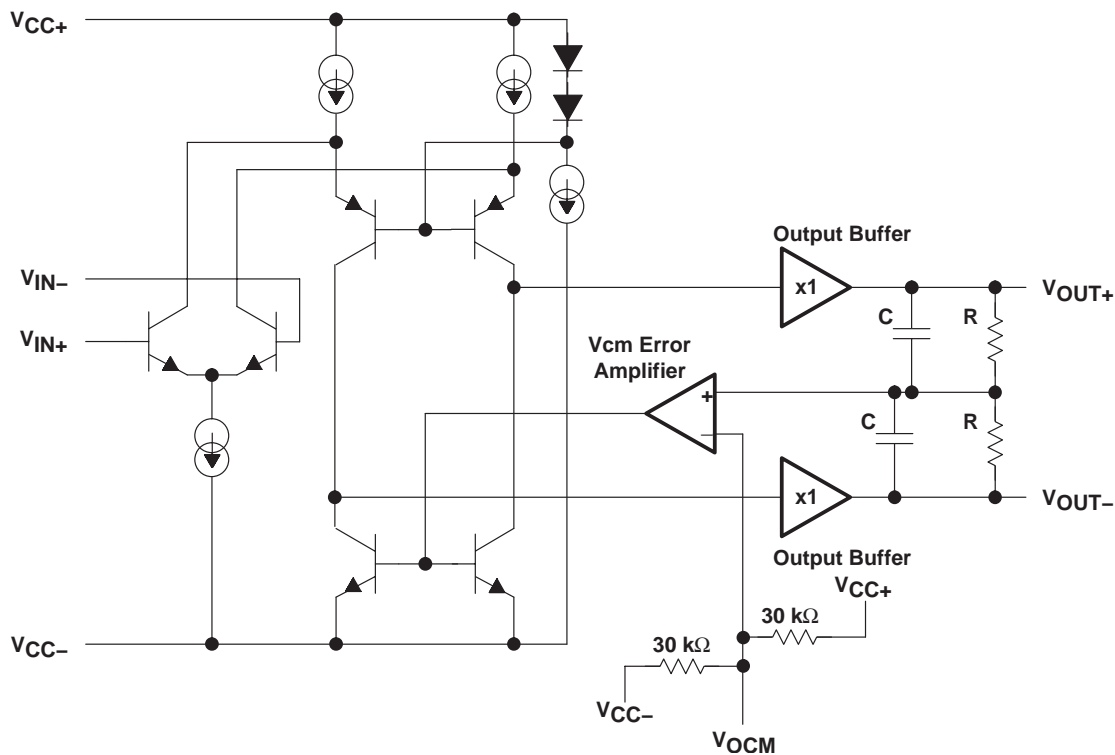

Figure 29. THS413x Simplified Diagram

APPLICATION INFORMATION

data converters

Data converters are one of the most popular applications for the fully differential amplifiers. The following schematic shows a typical configuration of a fully differential amplifier attached to a differential ADC.

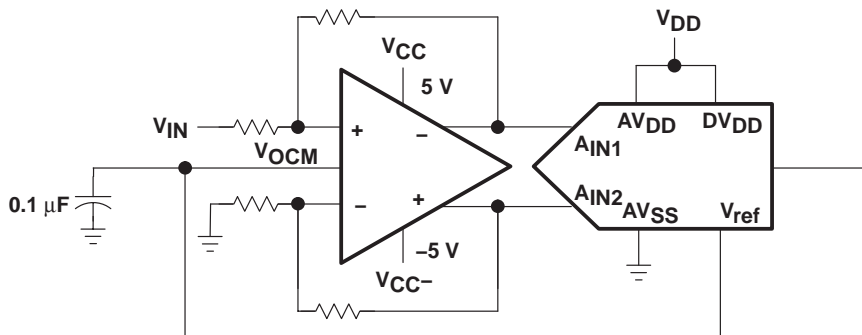

Figure 30. Fully Differential Amplifier Attached to a Differential ADC

Fully differential amplifiers can operate with a single supply. V_{OCM} defaults to the midrail voltage, $V_{CC}/2$. The differential output may be fed into a data converter. This method eliminates the use of a transformer in the circuit. If the ADC has a reference voltage output (V_{ref}), then it is recommended to connect it directly to the V_{OCM} of the amplifier using a bypass capacitor for stability. For proper operation, the input common-mode voltage to the input terminal of the amplifier should not exceed the common-mode input voltage range.

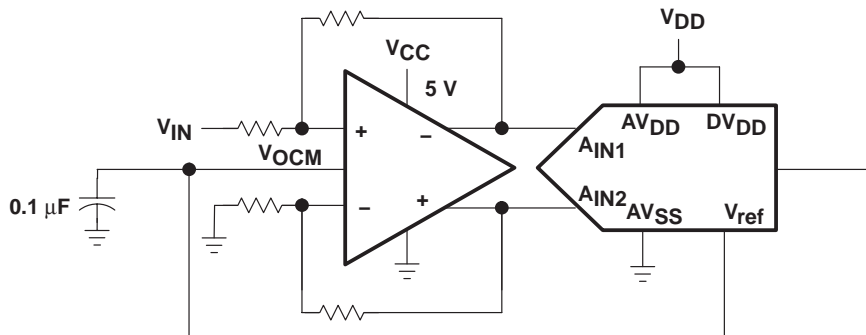

Figure 31. Fully Differential Amplifier Using a Single Supply

THS4130, THS4131 HIGH-SPEED, LOW NOISE, FULLY-DIFFERENTIAL I/O AMPLIFIERS

SLOS318E – MAY 2000 – REVISED JANUARY 2004

APPLICATION INFORMATION

data converters (continued)

Some single supply applications may require the input voltage to exceed the common-mode input voltage range. In such cases, the following circuit configuration is suggested to bring the common-mode input voltage within the specifications of the amplifier.

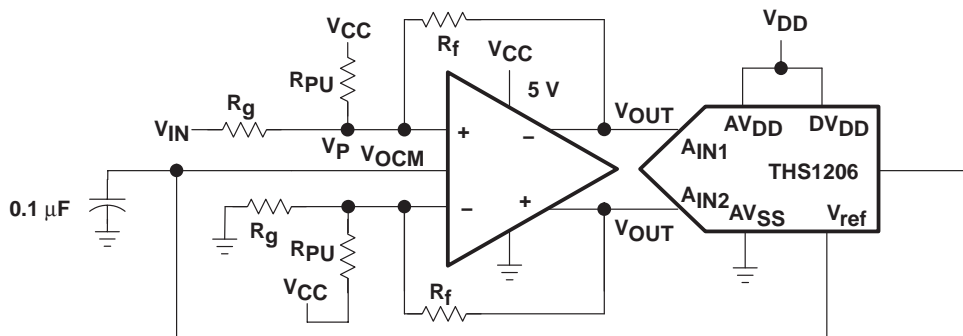

Figure 32. Circuit With Improved Common-Mode Input Voltage

The following equation is used to calculate R_{PU} :

$$R_{PU} = \frac{V_P - V_{CC}}{(V_{IN} - V_P) \frac{1}{R_G} + (V_{OUT} - V_P) \frac{1}{R_F}}$$

driving a capacitive load

Driving capacitive loads with high performance amplifiers is not a problem as long as certain precautions are taken. The first is to realize that the THS413x has been internally compensated to maximize its bandwidth and slew rate performance. When the amplifier is compensated in this manner, capacitive loading directly on the output will decrease the device's phase margin leading to high frequency ringing or oscillations. Therefore, for capacitive loads of greater than 10 pF, it is recommended that a resistor be placed in series with the output of the amplifier, as shown in Figure 33. A minimum value of 20 Ω should work well for most applications. For example, in 50- Ω transmission systems, setting the series resistor value to 50 Ω both isolates any capacitance loading and provides the proper line impedance matching at the source end.

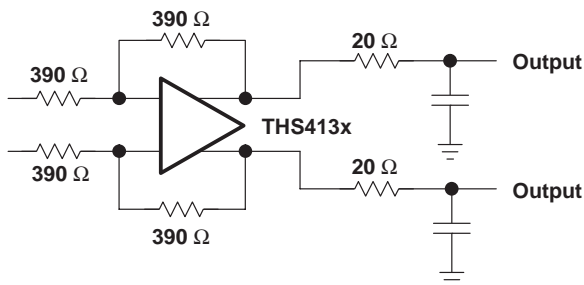

Figure 33. Driving a Capacitive Load

APPLICATION INFORMATION

Active antialias filtering

For signal conditioning in ADC applications, it is important to limit the input frequency to the ADC. Low-pass filters can prevent the aliasing of the high frequency noise with the frequency of operation. The following figure presents a method by which the noise may be filtered in the THS413x.

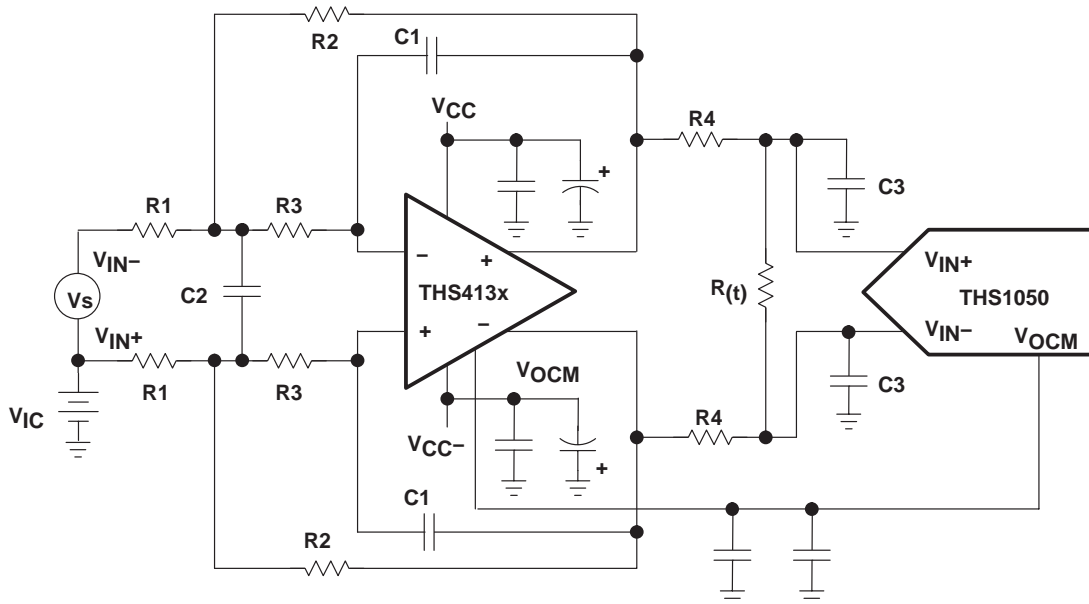

Figure 34. Antialias Filtering

The transfer function for this filter circuit is:

$$H_d(f) = \left(\frac{K}{-\left(\frac{f}{\text{FSF} \times f_c}\right)^2 + \frac{1}{Q} \frac{jf}{\text{FSF} \times f_c} + 1} \right) \times \left(\frac{\frac{R_t}{2R_4 + R_t}}{1 + \frac{j2\pi f R_4 R_t C_3}{2R_4 + R_t}} \right) \quad \text{Where } K = \frac{R_2}{R_1}$$

$$\text{FSF} \times f_c = \frac{1}{2\pi \sqrt{2 \times R_2 R_3 C_1 C_2}} \quad \text{and } Q = \frac{\sqrt{2 \times R_2 R_3 C_1 C_2}}{R_3 C_1 + R_2 C_1 + K R_3 C_1}$$

K sets the pass band gain, f_c is the cutoff frequency for the filter, FSF is a frequency scaling factor, and Q is the quality factor.

$$\text{FSF} = \sqrt{\text{Re}^2 + |\text{Im}|^2} \quad \text{and } Q = \frac{\sqrt{\text{Re}^2 + |\text{Im}|^2}}{2\text{Re}}$$

where Re is the real part, and Im is the imaginary part of the complex pole pair. Setting $R_2 = R$, $R_3 = mR$, $C_1 = C$, and $C_2 = nC$ results in:

$$\text{FSF} \times f_c = \frac{1}{2\pi R C \sqrt{2 \times m n}} \quad \text{and } Q = \frac{\sqrt{2 \times m n}}{1 + m(1 + K)}$$

Start by determining the ratios, m and n, required for the gain and Q of the filter type being designed, then select C and calculate R for the desired f_c .

THS4130, THS4131 HIGH-SPEED, LOW NOISE, FULLY-DIFFERENTIAL I/O AMPLIFIERS

SLOS318E – MAY 2000 – REVISED JANUARY 2004

PRINCIPLES OF OPERATION

theory of operation

The THS413x is a fully differential amplifier. Differential amplifiers are typically *differential in/single out*, whereas fully differential amplifiers are *differential in/differential out*.

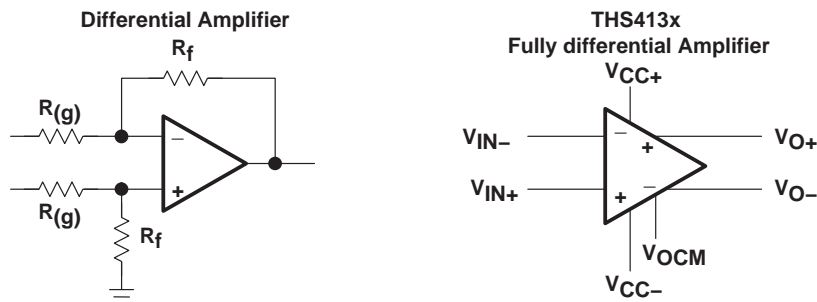

Figure 35. Differential Amplifier Versus a Fully Differential Amplifier

To understand the THS413x fully differential amplifiers, the definition for the pinouts of the amplifier are provided.

Input voltage definition $V_{ID} = (V_{I+}) - (V_{I-})$ $V_{IC} = \frac{(V_{I+}) + (V_{I-})}{2}$

Output voltage definition $V_{OD} = (V_{O+}) - (V_{O-})$ $V_{OC} = \frac{(V_{O+}) + (V_{O-})}{2}$

Transfer function $V_{OD} = V_{ID} \times A_{(f)}$

Output common mode voltage $V_{OC} = V_{OCM}$

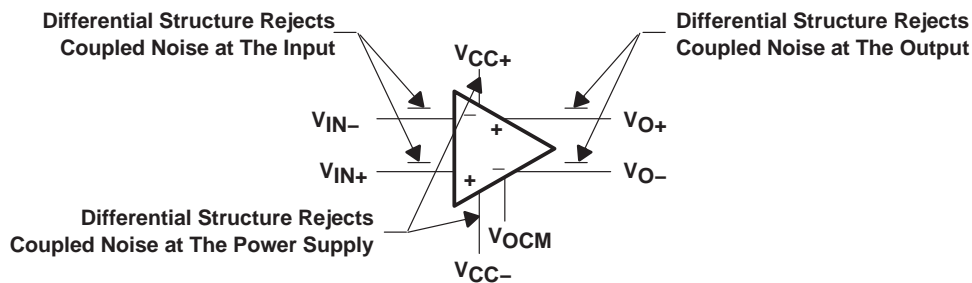
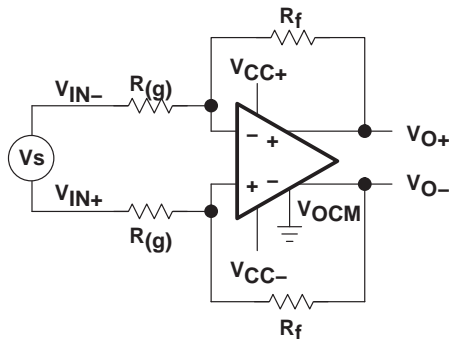

Figure 36. Definition of the Fully Differential Amplifier

PRINCIPLES OF OPERATION

theory of operation (continued)

The following schematics depict the differences between the operation of the THS413x, fully differential amplifier, in two different modes. Fully differential amplifiers can work with differential input or can be implemented as single in/differential out.



Note: For proper operation, maintain symmetry by setting $R_{f1} = R_{f2} = R_f$ and $R_{(g)1} = R_{(g)2} = R_{(g)} \Rightarrow A = R_f/R_{(g)}$

Figure 37. Amplifying Differential Signals

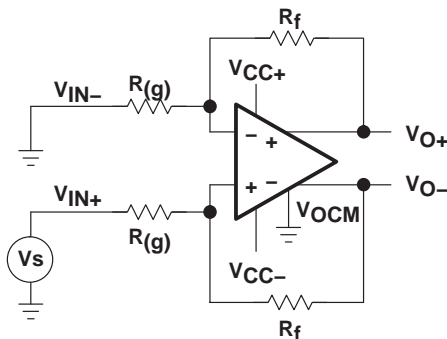

RECOMMENDED RESISTOR VALUES

GAIN	R(g) Ω	R_f Ω
1	390	390
2	374	750
5	402	2010
10	402	4020

Figure 38. Single In With Differential Out

If each output is measured independently, each output is one-half of the input signal when gain is 1. The following equations express the transfer function for each output:

$$V_{O+} = \frac{1}{2} V_I$$

The second output is equal and opposite in sign:

$$V_{O-} = -\frac{1}{2} V_I$$

THS4130, THS4131 HIGH-SPEED, LOW NOISE, FULLY-DIFFERENTIAL I/O AMPLIFIERS

SLOS318E – MAY 2000 – REVISED JANUARY 2004

PRINCIPLES OF OPERATION

theory of operation (continued)

Fully differential amplifiers may be viewed as two inverting amplifiers. In this case, the equation of an inverting amplifier holds true for gain calculations. One advantage of fully differential amplifiers is that they offer twice as much dynamic range compared to single-ended amplifiers. For example, a $1-V_{PP}$ ADC can only support an input signal of $1 V_{PP}$. If the output of the amplifier is $2 V_{PP}$, then it will not be practical to feed a $2-V_{PP}$ signal into the targeted ADC. Using a fully differential amplifier enables the user to break down the output into two $1-V_{PP}$ signals with opposite signs and feed them into the differential input nodes of the ADC. In practice, the designer has been able to feed a $2-V$ peak-to-peak signal into a $1-V$ differential ADC with the help of a fully differential amplifier. The final result indicates twice as much dynamic range. Figure 39 illustrates the increase in dynamic range. The gain factor should be considered in this scenario. The THS413x fully differential amplifier offers an improved CMRR and PSRR due to its symmetrical input and output. Furthermore, second harmonic distortion is improved. Second harmonics tend to cancel because of the symmetrical output.

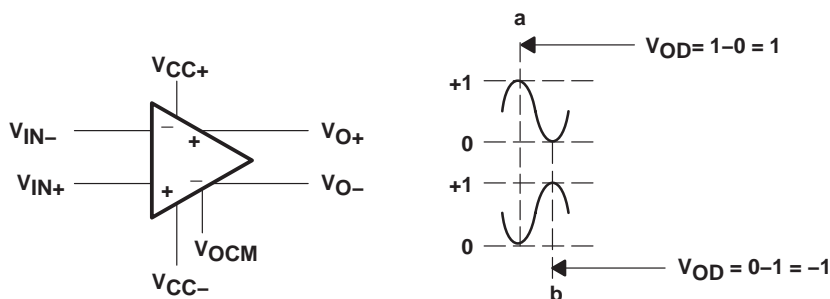

Figure 39. Fully Differential Amplifier With Two $1-V_{PP}$ Signals

Similar to the standard inverting amplifier configuration, input impedance of a fully differential amplifier is selected by the input resistor, $R_{(g)}$. If input impedance is a constraint in design, the designer may choose to implement the differential amplifier as an instrumentation amplifier. This configuration improves the input impedance of the fully differential amplifier. The following schematic depicts the general format of instrumentation amplifiers.

The general transfer function for this circuit is:

$$\frac{V_{OD}}{V_{IN1} - V_{IN2}} = \frac{R_f}{R_{(g)}} \left(1 + \frac{2R_2}{R_1} \right)$$

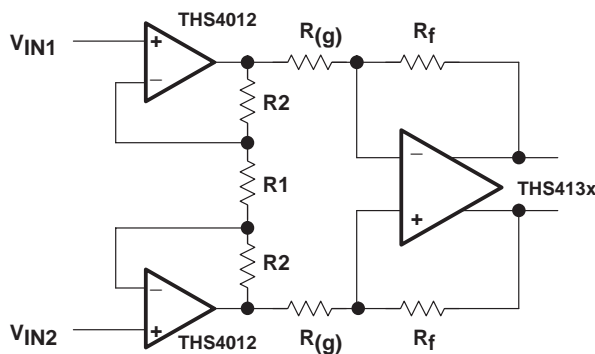

Figure 40. Instrumentation Amplifier

PRINCIPLES OF OPERATION

circuit layout considerations

To achieve the levels of high frequency performance of the THS413x, follow proper printed-circuit board high frequency design techniques. A general set of guidelines is given below. In addition, a THS413x evaluation board is available to use as a guide for layout or for evaluating the device performance.

- Ground planes—It is highly recommended that a ground plane be used on the board to provide all components with a low inductive ground connection. However, in the areas of the amplifier inputs and output, the ground plane can be removed to minimize the stray capacitance.
- Proper power supply decoupling—Use a 6.8- μ F tantalum capacitor in parallel with a 0.1- μ F ceramic capacitor on each supply terminal. It may be possible to share the tantalum among several amplifiers depending on the application, but a 0.1- μ F ceramic capacitor should always be used on the supply terminal of every amplifier. In addition, the 0.1- μ F capacitor should be placed as close as possible to the supply terminal. As this distance increases, the inductance in the connecting trace makes the capacitor less effective. The designer should strive for distances of less than 0.1 inches between the device power terminals and the ceramic capacitors.
- Sockets—Sockets are not recommended for high-speed operational amplifiers. The additional lead inductance in the socket pins will often lead to stability problems. Surface-mount packages soldered directly to the printed-circuit board is the best implementation.
- Short trace runs/compact part placements—Optimum high frequency performance is achieved when stray series inductance has been minimized. To realize this, the circuit layout should be made as compact as possible, thereby minimizing the length of all trace runs. Particular attention should be paid to the inverting input of the amplifier. Its length should be kept as short as possible. This will help to minimize stray capacitance at the input of the amplifier.
- Surface-mount passive components—Using surface-mount passive components is recommended for high frequency amplifier circuits for several reasons. First, because of the extremely low lead inductance of surface-mount components, the problem with stray series inductance is greatly reduced. Second, the small size of surface-mount components naturally leads to a more compact layout thereby minimizing both stray inductance and capacitance. If leaded components are used, it is recommended that the lead lengths be kept as short as possible.

THS4130, THS4131 HIGH-SPEED, LOW NOISE, FULLY-DIFFERENTIAL I/O AMPLIFIERS

SLOS318E – MAY 2000 – REVISED JANUARY 2004

PRINCIPLES OF OPERATION

power-down mode

The power-down mode is used when power saving is required. The power-down terminal ($\overline{\text{PD}}$) found on the THS413x is an active low terminal. If it is left as a no-connect terminal, the device will always stay on due to an internal 50 k Ω resistor to V_{CC} . The threshold voltage for this terminal is approximately 1.4 V above $V_{\text{CC-}}$. This means that if the $\overline{\text{PD}}$ terminal is 1.4 V above $V_{\text{CC-}}$, the device is active. If the $\overline{\text{PD}}$ terminal is less than 1.4 V above $V_{\text{CC-}}$, the device is off. For example, if $V_{\text{CC-}} = -5$ V, then the device is on when PD reaches -3.6 V, (-5 V + 1.4 V = -3.6 V). By the same calculation, the device is off below -3.6 V. It is recommended to pull the terminal to $V_{\text{CC-}}$ in order to turn the device off. The following graph shows the simplified version of the power-down circuit. While in the power-down state, the amplifier goes into a high impedance state. The amplifier output impedance is typically greater than 1 M Ω in the power-down state.

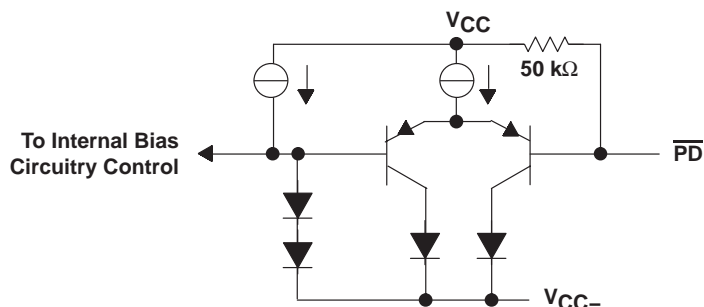

Figure 41. Simplified Power-Down Circuit

Due to the similarity of the standard inverting amplifier configuration, the output impedance appears to be very low while in the power-down state. This is because the feedback resistor (R_f) and the gain resistor ($R_{(g)}$) are still connected to the circuit. Therefore, a current path is allowed between the input of the amplifier and the output of the amplifier. An example of the closed loop output impedance is shown in Figure 42.

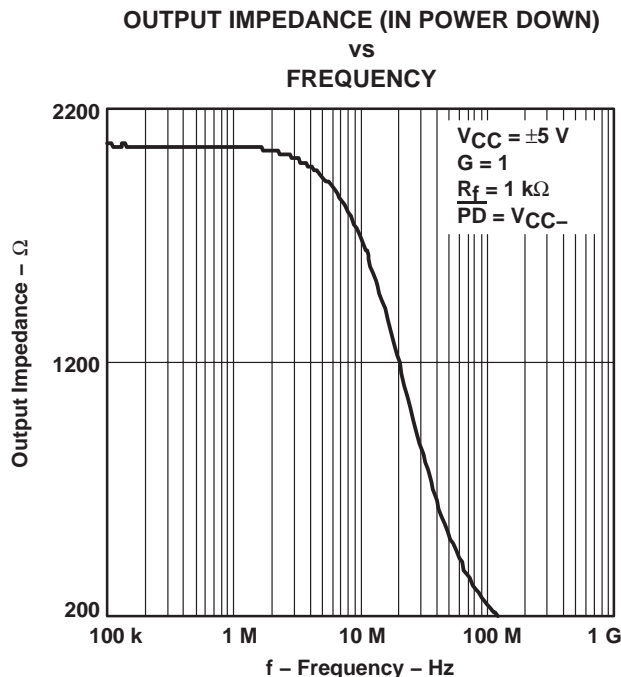

Figure 42

PRINCIPLES OF OPERATION

general PowerPAD design considerations

The THS413x is available packaged in a thermally-enhanced DGN package, which is a member of the PowerPAD family of packages. This package is constructed using a downset leadframe upon which the die is mounted [see Figure 43(a) and Figure 43(b)]. This arrangement results in the lead frame being exposed as a thermal pad on the underside of the package [see Figure 43(c)]. Because this thermal pad has direct thermal contact with the die, excellent thermal performance can be achieved by providing a good thermal path away from the thermal pad.

The PowerPAD package allows for both assembly and thermal management in one manufacturing operation. During the surface-mount solder operation (when the leads are being soldered), the thermal pad can also be soldered to a copper area underneath the package. Through the use of thermal paths within this copper area, heat can be conducted away from the package into either a ground plane or other heat dissipating device.

The PowerPAD package represents a breakthrough in combining the small area and ease of assembly of the surface mount with the, heretofore, awkward mechanical methods of heatsinking.

More complete details of the PowerPAD installation process and thermal management techniques can be found in the Texas Instruments Technical Brief, *PowerPAD Thermally Enhanced Package (SLMA002)*. This document can be found at the TI web site (www.ti.com) by searching on the key word PowerPAD. The document can also be ordered through your local TI sales office. Refer to literature number SLMA002 when ordering.

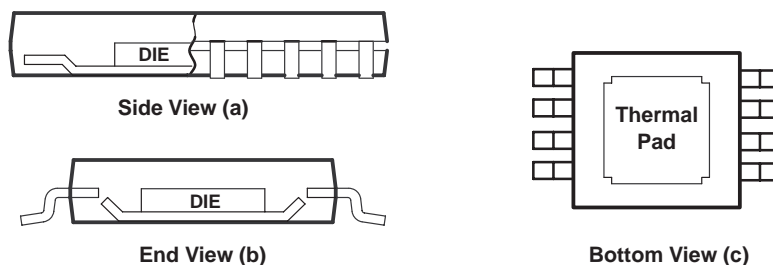

NOTE A: The thermal pad is electrically isolated from all terminals in the package.

Figure 43. Views of Thermally Enhanced DGN Package

DGK (S-PDSO-G8)

PLASTIC SMALL-OUTLINE PACKAGE

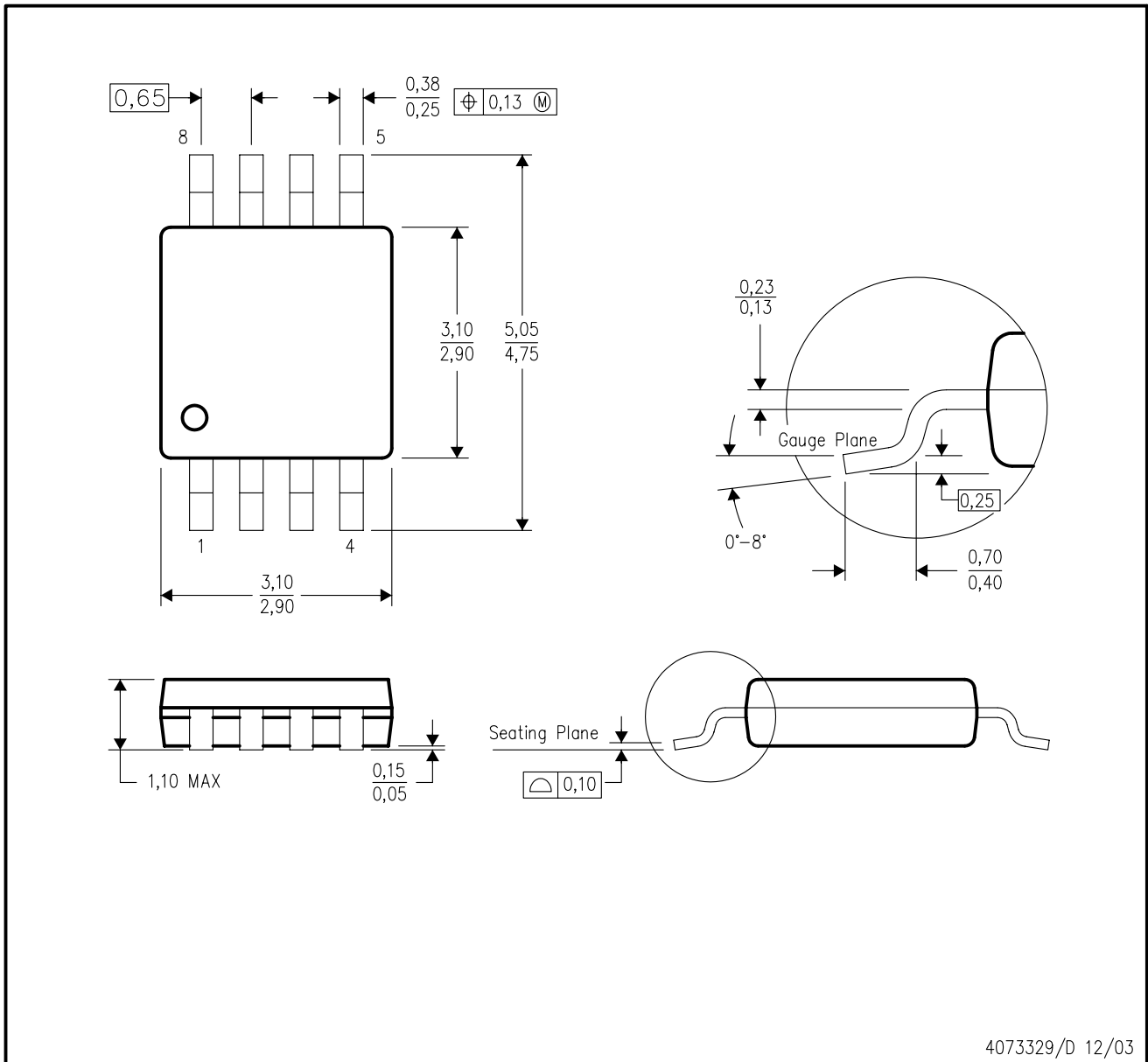

- NOTES:
- A. All linear dimensions are in millimeters.
 - B. This drawing is subject to change without notice.
 - C. Body dimensions do not include mold flash or protrusion.
 - D. Falls within JEDEC MO-187 variation AA.

DGN (S-PDSO-G8)

PowerPAD™ PLASTIC SMALL-OUTLINE PACKAGE

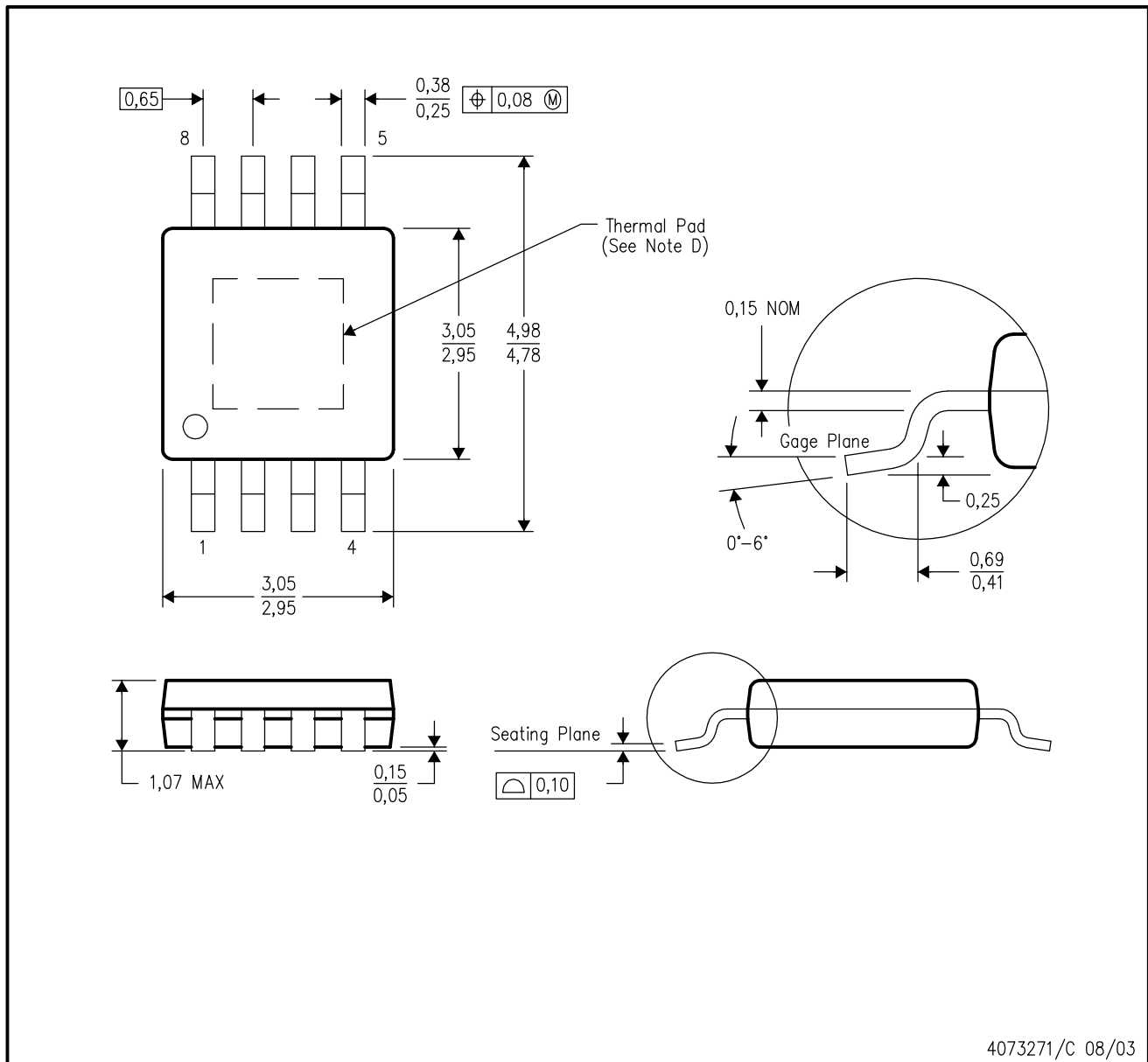

- NOTES:
- All linear dimensions are in millimeters.
 - This drawing is subject to change without notice.
 - Body dimensions do not include mold flash or protrusion.
 - This package is designed to be soldered to a thermal pad on the board. Refer to Technical Brief, PowerPad Thermally Enhanced Package, Texas Instruments Literature No. SLMA002 for information regarding recommended board layout. This document is available at www.ti.com <<http://www.ti.com>>.
 - Falls within JEDEC MO-187

PowerPAD is a trademark of Texas Instruments.

D (R-PDSO-G8)

PLASTIC SMALL-OUTLINE PACKAGE

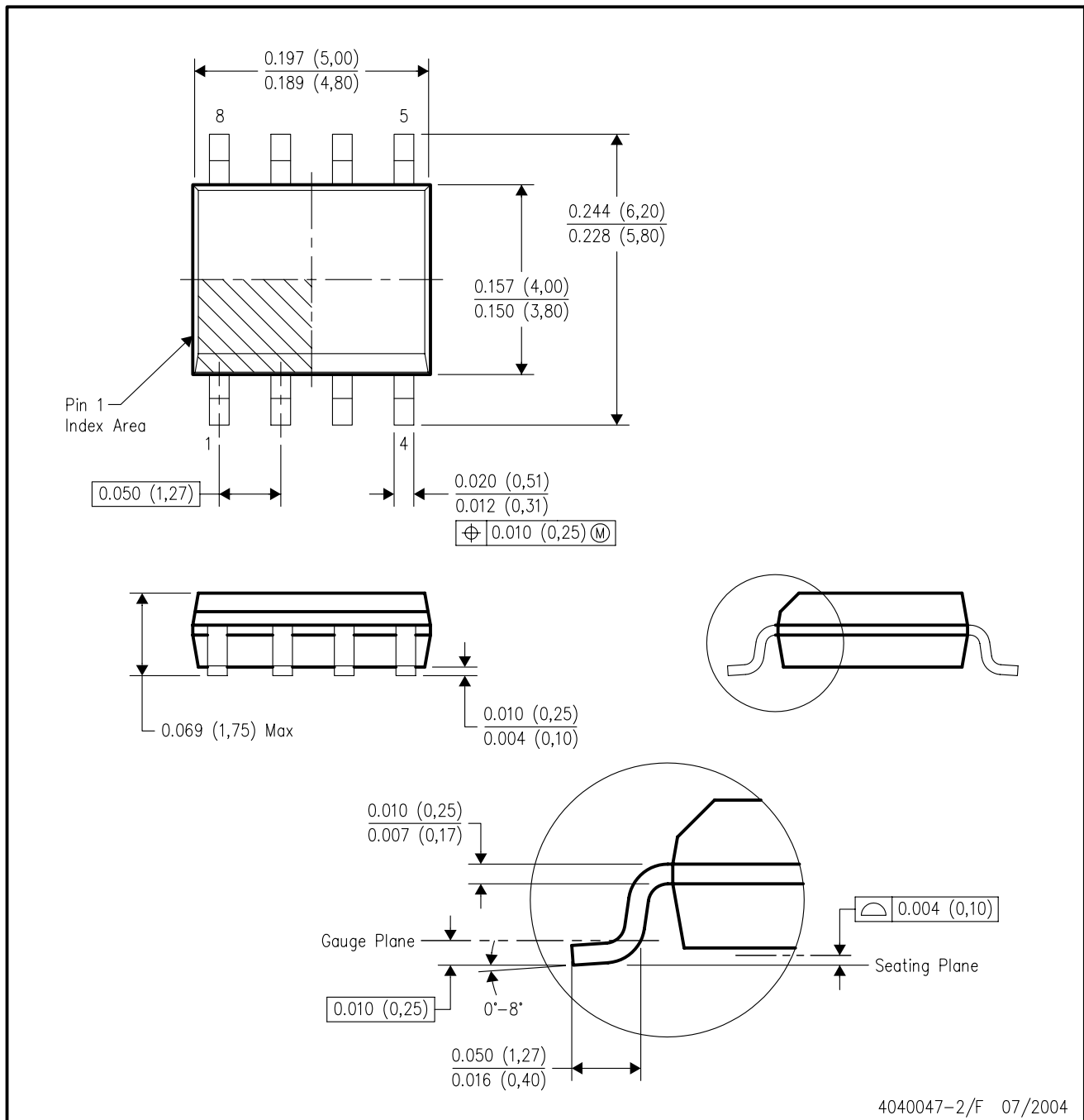

- NOTES:
- A. All linear dimensions are in inches (millimeters).
 - B. This drawing is subject to change without notice.
 - C. Body dimensions do not include mold flash or protrusion not to exceed 0.006 (0,15).
 - D. Falls within JEDEC MS-012 variation AA.

IMPORTANT NOTICE

Texas Instruments Incorporated and its subsidiaries (TI) reserve the right to make corrections, modifications, enhancements, improvements, and other changes to its products and services at any time and to discontinue any product or service without notice. Customers should obtain the latest relevant information before placing orders and should verify that such information is current and complete. All products are sold subject to TI's terms and conditions of sale supplied at the time of order acknowledgment.

TI warrants performance of its hardware products to the specifications applicable at the time of sale in accordance with TI's standard warranty. Testing and other quality control techniques are used to the extent TI deems necessary to support this warranty. Except where mandated by government requirements, testing of all parameters of each product is not necessarily performed.

TI assumes no liability for applications assistance or customer product design. Customers are responsible for their products and applications using TI components. To minimize the risks associated with customer products and applications, customers should provide adequate design and operating safeguards.

TI does not warrant or represent that any license, either express or implied, is granted under any TI patent right, copyright, mask work right, or other TI intellectual property right relating to any combination, machine, or process in which TI products or services are used. Information published by TI regarding third-party products or services does not constitute a license from TI to use such products or services or a warranty or endorsement thereof. Use of such information may require a license from a third party under the patents or other intellectual property of the third party, or a license from TI under the patents or other intellectual property of TI.

Reproduction of information in TI data books or data sheets is permissible only if reproduction is without alteration and is accompanied by all associated warranties, conditions, limitations, and notices. Reproduction of this information with alteration is an unfair and deceptive business practice. TI is not responsible or liable for such altered documentation.

Resale of TI products or services with statements different from or beyond the parameters stated by TI for that product or service voids all express and any implied warranties for the associated TI product or service and is an unfair and deceptive business practice. TI is not responsible or liable for any such statements.

Following are URLs where you can obtain information on other Texas Instruments products and application solutions:

Products		Applications	
Amplifiers	amplifier.ti.com	Audio	www.ti.com/audio
Data Converters	dataconverter.ti.com	Automotive	www.ti.com/automotive
DSP	dsp.ti.com	Broadband	www.ti.com/broadband
Interface	interface.ti.com	Digital Control	www.ti.com/digitalcontrol
Logic	logic.ti.com	Military	www.ti.com/military
Power Mgmt	power.ti.com	Optical Networking	www.ti.com/opticalnetwork
Microcontrollers	microcontroller.ti.com	Security	www.ti.com/security
		Telephony	www.ti.com/telephony
		Video & Imaging	www.ti.com/video
		Wireless	www.ti.com/wireless

Mailing Address: Texas Instruments
Post Office Box 655303 Dallas, Texas 75265