

TPA6111A2 150-mW STEREO AUDIO POWER AMPLIFIER

SLOS313A – DECEMBER 2000 – REVISED OCTOBER 2002

- 150 mW Stereo Output
- PC Power Supply Compatible
 - Fully Specified for 3.3-V and 5-V Operation
 - Operation to 2.5 V
- Pop Reduction Circuitry
- Internal Midrail Generation
- Thermal and Short-Circuit Protection
- Surface-Mount Packaging
 - PowerPAD™ MSOP
 - SOIC
- Pin Compatible With TPA122, LM4880, and LM4881 (SOIC)

D OR DGN PACKAGE
(TOP VIEW)

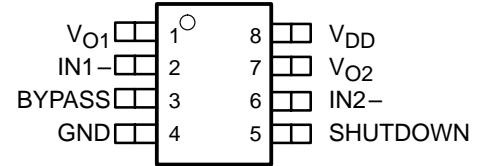

description

The TPA6111A2 is a stereo audio power amplifier packaged in either an 8-pin SOIC or an 8-pin PowerPAD™ MSOP package capable of delivering 150 mW of continuous RMS power per channel into 16-Ω loads. Amplifier gain is externally configured by means of two resistors per input channel and does not require external compensation for settings of 0 to 20 dB.

THD+N, when driving a 16-Ω load from 5 V, is 0.03% at 1 kHz, and less than 1% across the audio band of 20 Hz to 20 kHz. For 32-Ω loads, the THD+N is reduced to less than 0.02% at 1 kHz, and is less than 1% across the audio band of 20 Hz to 20 kHz. For 10-kΩ loads, the THD+N performance is 0.005% at 1 kHz, and less than 0.5% across the audio band of 20 Hz to 20 kHz.

typical application circuit

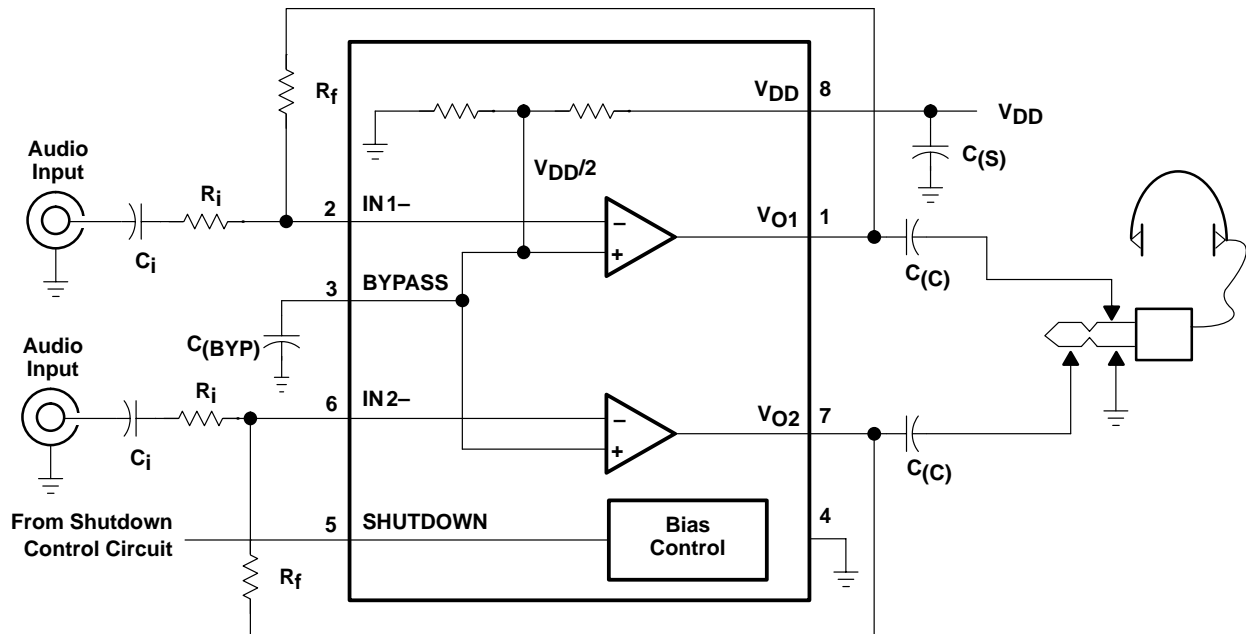

Please be aware that an important notice concerning availability, standard warranty, and use in critical applications of Texas Instruments semiconductor products and disclaimers thereto appears at the end of this data sheet.

PowerPAD is a trademark of Texas Instruments.

PRODUCTION DATA information is current as of publication date. Products conform to specifications per the terms of Texas Instruments standard warranty. Production processing does not necessarily include testing of all parameters.

**TEXAS
INSTRUMENTS**

POST OFFICE BOX 655303 • DALLAS, TEXAS 75265

Copyright © 2002, Texas Instruments Incorporated

TPA6111A2

150-mW STEREO AUDIO POWER AMPLIFIER

SLOS313A – DECEMBER 2000 – REVISED OCTOBER 2002

AVAILABLE OPTIONS

| T _A | PACKAGED DEVICES | | MSOP Symbolization |
|----------------|--------------------|--------------|--------------------|
| | SMALL OUTLINE† (D) | MSOPT† (DGN) | |
| –40°C to 85°C | TPA6111A2D | TPA6111A2DGN | TI AJA |

† The D and DGN package is available in left-ended tape and reel only (e.g., TPA6111A2DR, TPA6111A2DGNR).

Terminal Functions

| TERMINAL NAME | NO. | I/O | DESCRIPTION |
|-----------------|-----|-----|---|
| BYPASS | 3 | I | Tap to voltage divider for internal mid-supply bias supply. Connect to a 0.1 μF to 1 μF low ESR capacitor for best performance. |
| GND | 4 | I | GND is the ground connection. |
| IN1– | 2 | I | IN1– is the inverting input for channel 1. |
| IN2– | 6 | I | IN2– is the inverting input for channel 2. |
| SHUTDOWN | 5 | I | Puts the device in a low quiescent current mode when held high |
| V _{DD} | 8 | I | V _{DD} is the supply voltage terminal. |
| V _{O1} | 1 | O | V _{O1} is the audio output for channel 1. |
| V _{O2} | 7 | O | V _{O2} is the audio output for channel 2. |

absolute maximum ratings over operating free-air temperature (unless otherwise noted)‡

| | |
|--|-----------------------------------|
| Supply voltage, V _{DD} | 6 V |
| Input voltage, V _I | –0.3 V to V _{DD} + 0.3 V |
| Continuous total power dissipation | internally limited |
| Operating junction temperature range, T _J | –40°C to 150°C |
| Storage temperature range, T _{stg} | –65°C to 150°C |
| Lead temperature 1,6 mm (1/16 inch) from case for 10 seconds | 260°C |

‡ Stresses beyond those listed under “absolute maximum ratings” may cause permanent damage to the device. These are stress ratings only, and functional operation of the device at these or any other conditions beyond those indicated under “recommended operating conditions” is not implied. Exposure to absolute-maximum-rated conditions for extended periods may affect device reliability.

DISSIPATION RATING TABLE

| PACKAGE | T _A ≤ 25°C POWER RATING | DERATING FACTOR ABOVE T _A = 25°C | T _A = 70°C POWER RATING | T _A = 85°C POWER RATING |
|---------|---------------------------------------|--|---------------------------------------|---------------------------------------|
| D | 725 mW | 5.8 mW/°C | 464 mW | 377 mW |
| DGN | 2.14 W§ | 17.1 mW/°C | 1.37 W | 1.11 W |

§ See the Texas Instruments document, *PowerPAD Thermally Enhanced Package Application Report* (literature number SLMA002), for more information on the PowerPAD package. The thermal data was measured on a PCB layout based on the information in the section entitled *Texas Instruments Recommended Board for PowerPAD* on page 33 of the before mentioned document.

recommended operating conditions

| | MIN | MAX | UNIT |
|--|-----------------------|-----|------|
| Supply voltage, V _{DD} | 2.5 | 5.5 | V |
| Operating free-air temperature, T _A | –40 | 85 | °C |
| High-level input voltage, V _{IH} , (SHUTDOWN) | 60% x V _{DD} | | V |
| Low-level input voltage, V _{IL} , (SHUTDOWN) | 25% x V _{DD} | | V |



TPA6111A2

150-mW STEREO AUDIO POWER AMPLIFIER

SLOS313A – DECEMBER 2000 – REVISED OCTOBER 2002

dc electrical characteristics at $T_A = 25^\circ\text{C}$, $V_{DD} = 3.3\text{ V}$ (unless otherwise noted)

| PARAMETER | | TEST CONDITIONS | MIN | TYP | MAX | UNIT |
|--------------|---------------------------------|--|-----|-----|-----|---------------|
| V_{OO} | Output offset voltage | | | | 10 | mV |
| PSRR | Power supply rejection ratio | $V_{DD} = 3.2\text{ V to } 3.4\text{ V}$ | | 70 | | dB |
| I_{DD} | Supply current | SHUTDOWN (pin 5) = 0 V | | 1.5 | 3 | mA |
| $I_{DD(SD)}$ | Supply current in shutdown mode | SHUTDOWN (pin 5) = V_{DD} | | 1 | 10 | μA |
| Z_i | Input impedance | | | >1 | | M Ω |

ac operating characteristics, $V_{DD} = 3.3\text{ V}$, $T_A = 25^\circ\text{C}$, $R_L = 16\ \Omega$

| PARAMETER | | TEST CONDITIONS | MIN | TYP | MAX | UNIT |
|-----------|-----------------------------------|--|-----|------|-----|--------------------|
| P_O | Output power (each channel) | THD $\leq 0.1\%$, $f = 1\text{ kHz}$ | | 60 | | mW |
| THD+N | Total harmonic distortion + noise | $P_O = 40\text{ mW}$, 20 – 20 kHz | | 0.4% | | |
| B_{OM} | Maximum output power BW | G = 20 dB, THD < 5% | | >20 | | kHz |
| | Phase margin | Open loop | | 96° | | |
| | Supply ripple rejection | $f = 1\text{ kHz}$, $C_{(BYP)} = 0.47\ \mu\text{F}$ | | 71 | | dB |
| | Channel/channel output separation | $f = 1\text{ kHz}$, $P_O = 40\text{ mW}$ | | 89 | | dB |
| SNR | Signal-to-noise ratio | $P_O = 50\text{ mW}$, $A_V = 1$ | | 100 | | dB |
| V_n | Noise output voltage | $A_V = 1$ | | 11 | | $\mu\text{V(rms)}$ |

dc electrical characteristics at $T_A = 25^\circ\text{C}$, $V_{DD} = 5.5\text{ V}$

| PARAMETER | | TEST CONDITIONS | MIN | TYP | MAX | UNIT |
|--------------|-------------------------------------|--|-----|-----|-----|---------------|
| V_{OO} | Output offset voltage | | | | 10 | mV |
| PSRR | Power supply rejection ratio | $V_{DD} = 4.9\text{ V to } 5.1\text{ V}$ | | 70 | | dB |
| I_{DD} | Supply current | SHUTDOWN (pin 5) = 0 V | | 1.6 | 3.2 | mA |
| $I_{DD(SD)}$ | Supply current in shutdown mode | SHUTDOWN (pin 5) = V_{DD} | | 1 | 10 | μA |
| $ I_{IH} $ | High-level input current (SHUTDOWN) | $V_{DD} = 5.5\text{ V}$, $V_I = V_{DD}$ | | | 1 | μA |
| $ I_{IL} $ | Low-level input current (SHUTDOWN) | $V_{DD} = 5.5\text{ V}$, $V_I = 0\text{ V}$ | | | 1 | μA |
| Z_i | Input impedance | | | >1 | | M Ω |

ac operating characteristics, $V_{DD} = 5\text{ V}$, $T_A = 25^\circ\text{C}$, $R_L = 16\ \Omega$

| PARAMETER | | TEST CONDITIONS | MIN | TYP | MAX | UNIT |
|-----------|-----------------------------------|--|-----|------|-----|--------------------|
| P_O | Output power (each channel) | THD $\leq 0.1\%$, $f = 1\text{ kHz}$ | | 150 | | mW |
| THD+N | Total harmonic distortion + noise | $P_O = 100\text{ mW}$, 20 – 20 kHz | | 0.6% | | |
| B_{OM} | Maximum output power BW | G = 20 dB, THD < 5% | | >20 | | kHz |
| | Phase margin | Open loop | | 96° | | |
| | Supply ripple rejection ratio | $f = 1\text{ kHz}$, $C_{(BYP)} = 0.47\ \mu\text{F}$ | | 61 | | dB |
| | Channel/channel output separation | $f = 1\text{ kHz}$, $P_O = 100\text{ mW}$ | | 90 | | dB |
| SNR | Signal-to-noise ratio | $P_O = 100\text{ mW}$, $A_V = 1$ | | 100 | | dB |
| V_n | Noise output voltage | $A_V = 1$ | | 11.7 | | $\mu\text{V(rms)}$ |



TPA6111A2

150-mW STEREO AUDIO POWER AMPLIFIER

SLOS313A – DECEMBER 2000 – REVISED OCTOBER 2002

ac operating characteristics, $V_{DD} = 3.3\text{ V}$, $T_A = 25^\circ\text{C}$, $R_L = 32\ \Omega$

| PARAMETER | TEST CONDITIONS | MIN | TYP | MAX | UNIT |
|---|--|-----|------|-----|--------------------|
| P_O Output power (each channel) | THD \leq 0.1%, $f = 1\text{ kHz}$ | | 35 | | mW |
| THD+N Total harmonic distortion + noise | $P_O = 40\text{ mW}$, 20 – 20 kHz | | 0.4% | | |
| B_{OM} Maximum output power BW | $G = 20\text{ dB}$, THD < 2% | | >20 | | kHz |
| Phase margin | Open loop | | 96° | | |
| Supply ripple rejection | $f = 1\text{ kHz}$, $C_{(BYP)} = 0.47\ \mu\text{F}$ | | 71 | | dB |
| Channel/channel output separation | $f = 1\text{ kHz}$, $P_O = 25\text{ mW}$ | | 75 | | dB |
| SNR Signal-to-noise ratio | $P_O = 90\text{ mW}$, $A_V = 1$ | | 100 | | dB |
| V_n Noise output voltage | $A_V = 1$ | | 11 | | $\mu\text{V(rms)}$ |

ac operating characteristics, $V_{DD} = 5\text{ V}$, $T_A = 25^\circ\text{C}$, $R_L = 32\ \Omega$

| PARAMETER | TEST CONDITIONS | MIN | TYP | MAX | UNIT |
|---|--|-----|------|-----|--------------------|
| P_O Output power (each channel) | THD \leq 0.1%, $f = 1\text{ kHz}$ | | 90 | | mW |
| THD+N Total harmonic distortion + noise | $P_O = 20\text{ mW}$, 20 – 20 kHz | | 2% | | |
| B_{OM} Maximum output power BW | $G = 20\text{ dB}$, THD < 2% | | >20 | | kHz |
| Phase margin | Open loop | | 97° | | |
| Supply ripple rejection | $f = 1\text{ kHz}$, $C_{(BYP)} = 0.47\ \mu\text{F}$ | | 61 | | dB |
| Channel/channel output separation | $f = 1\text{ kHz}$, $P_O = 65\text{ mW}$ | | 98 | | dB |
| SNR Signal-to-noise ratio | $P_O = 90\text{ mW}$, $A_V = 1$ | | 104 | | dB |
| V_n Noise output voltage | $A_V = 1$ | | 11.7 | | $\mu\text{V(rms)}$ |

TYPICAL CHARACTERISTICS

Table of Graphs

| | | FIGURE |
|--|--------------------|---------------------------|
| THD+N Total harmonic distortion plus noise | vs Frequency | 1, 3, 5, 6, 7, 9, 11, 13, |
| | vs Output power | 2, 4, 8, 10, 12, 14 |
| Supply ripple rejection ratio | vs Frequency | 15, 16 |
| V_n Output noise voltage | vs Frequency | 17, 18 |
| Crosstalk | vs Frequency | 19 – 24 |
| Shutdown attenuation | vs Frequency | 25, 26 |
| Open-loop gain and phase margin | vs Frequency | 27, 28 |
| Output power | vs Load resistance | 29, 30, |
| I_{DD} Supply current | vs Supply voltage | 31 |
| SNR Signal-to-noise ratio | vs Voltage gain | 32 |
| Power dissipation/amplifier | vs Load power | 33, 34 |



TYPICAL CHARACTERISTICS

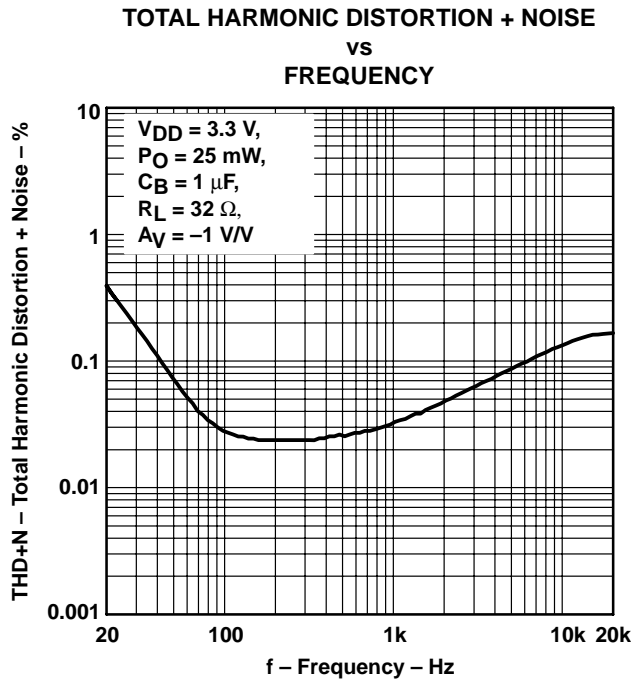

Figure 1

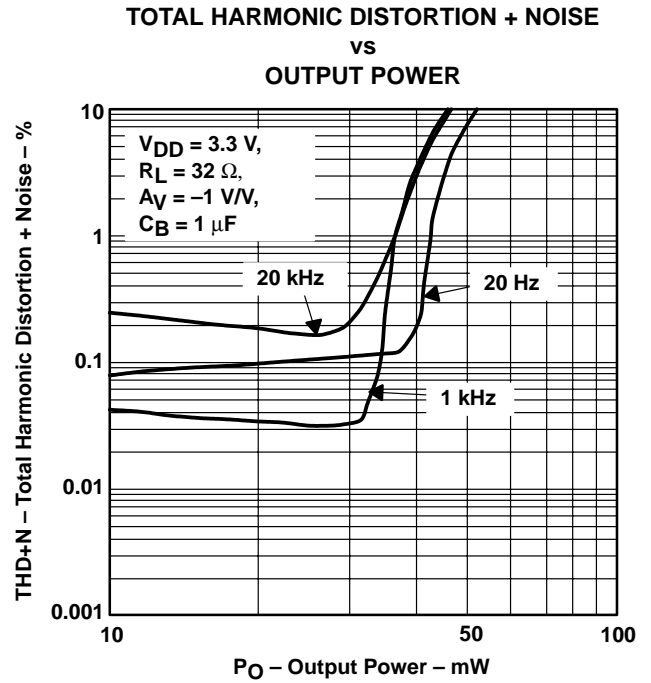

Figure 2

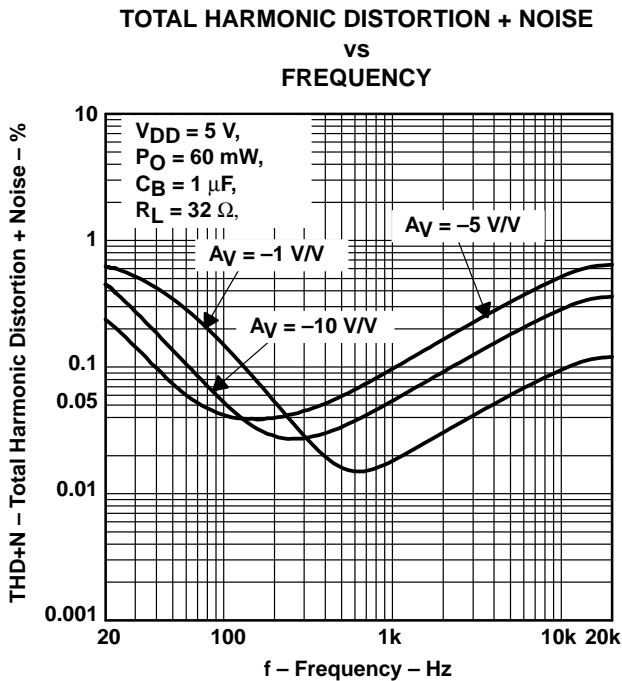

Figure 3

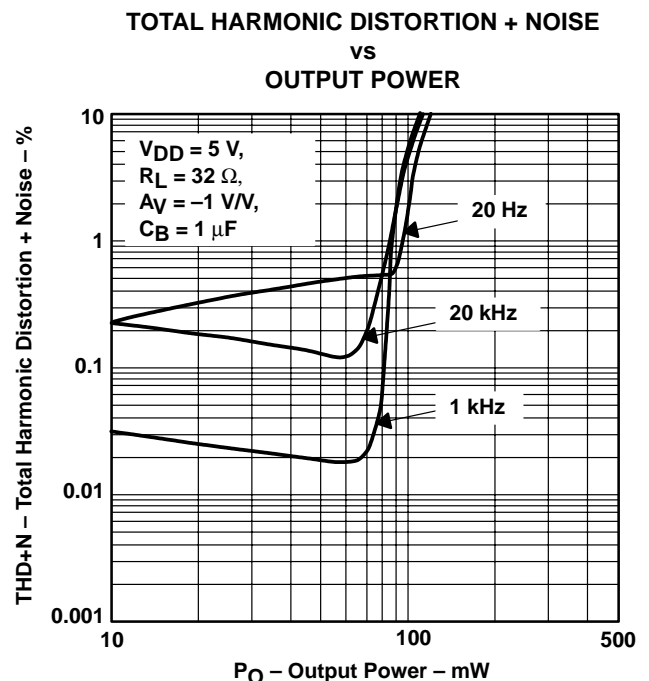

Figure 4

TPA6111A2 150-mW STEREO AUDIO POWER AMPLIFIER

SLOS313A – DECEMBER 2000 – REVISED OCTOBER 2002

TYPICAL CHARACTERISTICS

**TOTAL HARMONIC DISTORTION + NOISE
VS
FREQUENCY**

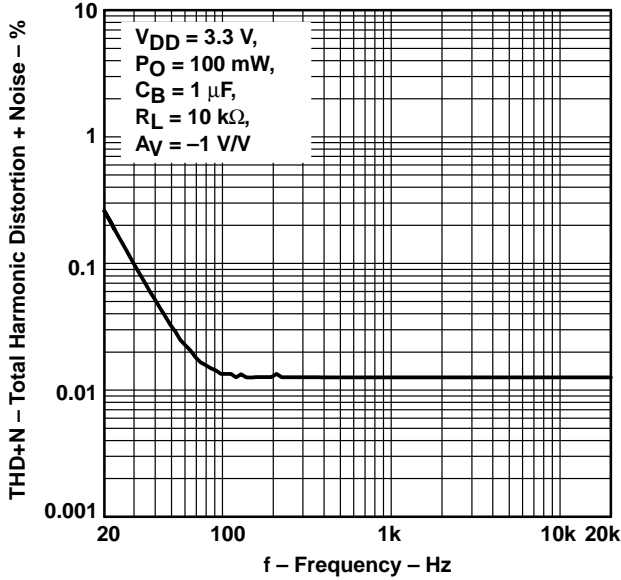

Figure 5

**TOTAL HARMONIC DISTORTION + NOISE
VS
FREQUENCY**

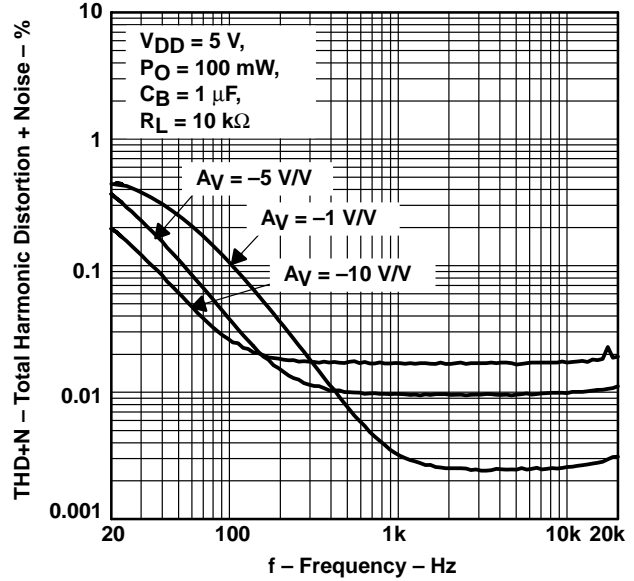

Figure 6

**TOTAL HARMONIC DISTORTION + NOISE
VS
FREQUENCY**

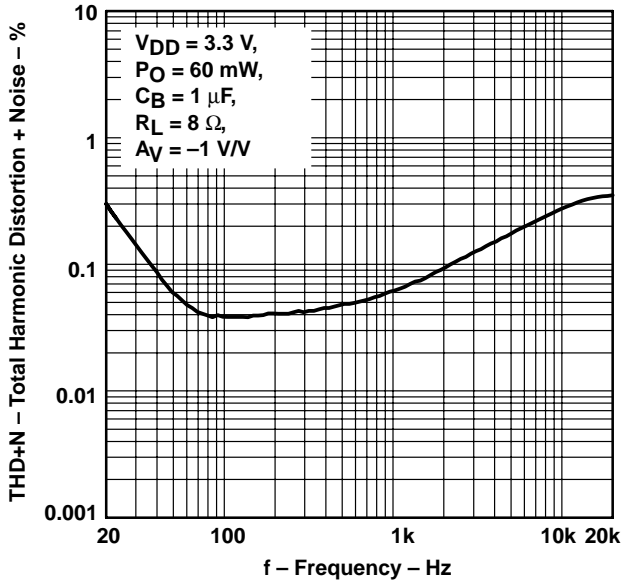

Figure 7

**TOTAL HARMONIC DISTORTION + NOISE
VS
OUTPUT POWER**

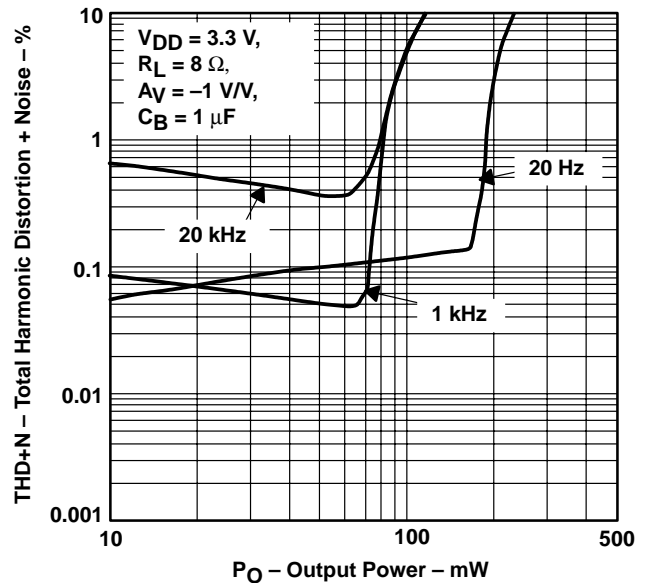

Figure 8



TYPICAL CHARACTERISTICS

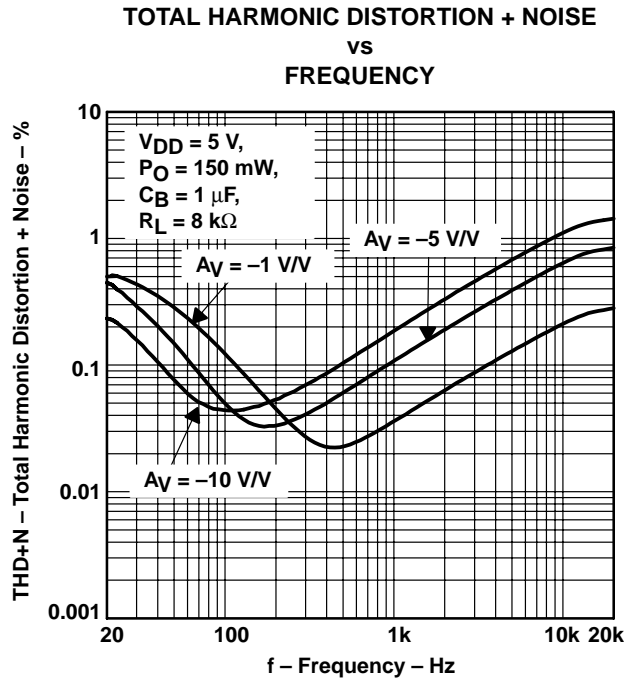

Figure 9

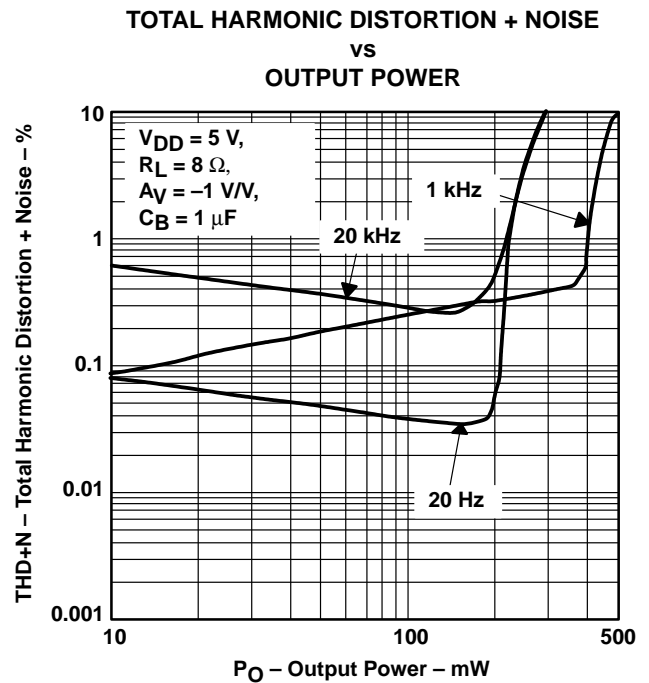

Figure 10

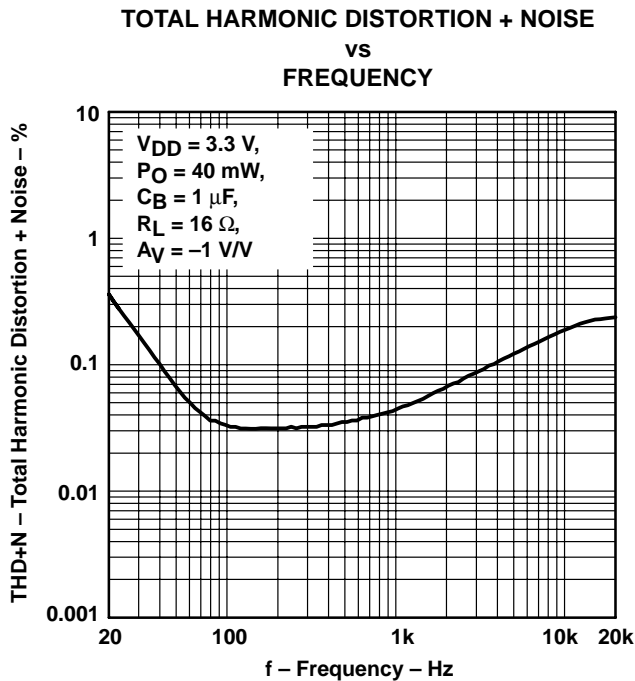

Figure 11

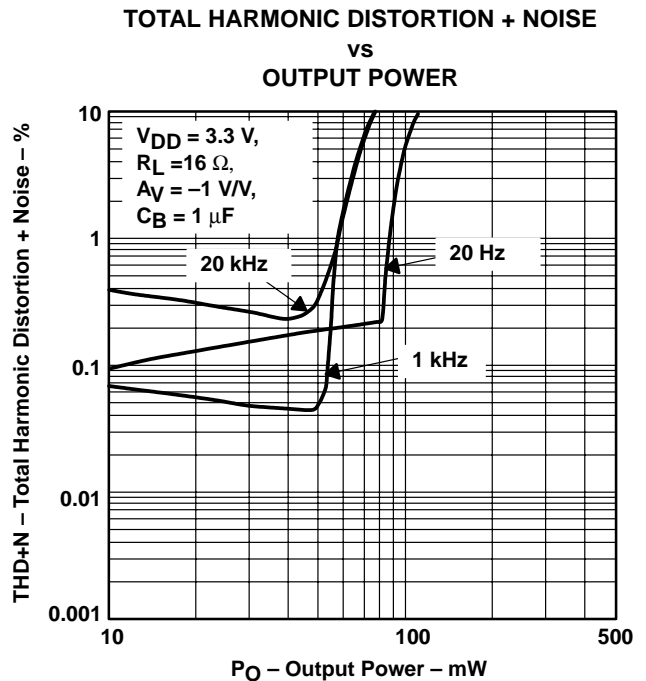

Figure 12

TPA6111A2 150-mW STEREO AUDIO POWER AMPLIFIER

SLOS313A – DECEMBER 2000 – REVISED OCTOBER 2002

TYPICAL CHARACTERISTICS

**TOTAL HARMONIC DISTORTION + NOISE
VS
FREQUENCY**

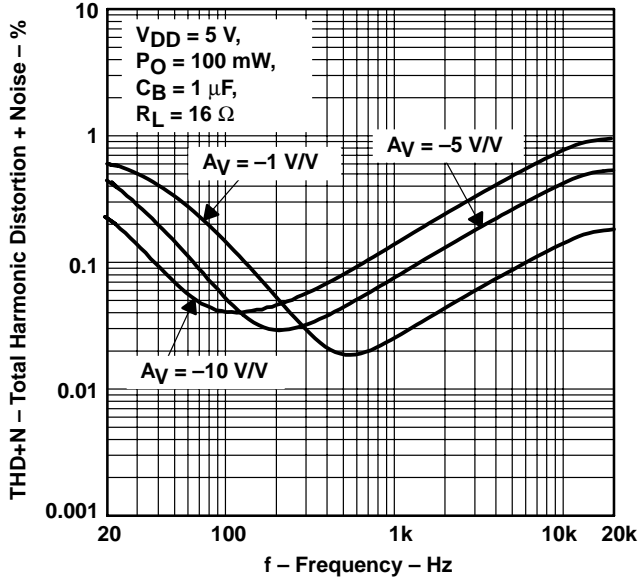

Figure 13

**TOTAL HARMONIC DISTORTION + NOISE
VS
OUTPUT POWER**

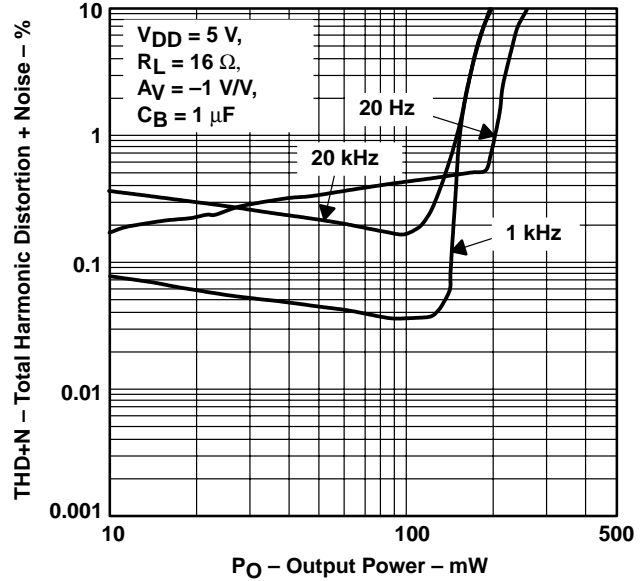

Figure 14

**SUPPLY RIPPLE REJECTION RATIO
VS
FREQUENCY**

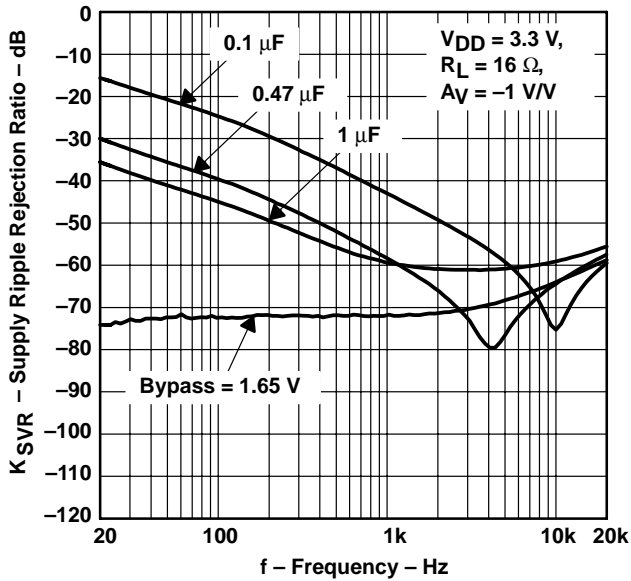

Figure 15

**SUPPLY RIPPLE REJECTION RATIO
VS
FREQUENCY**

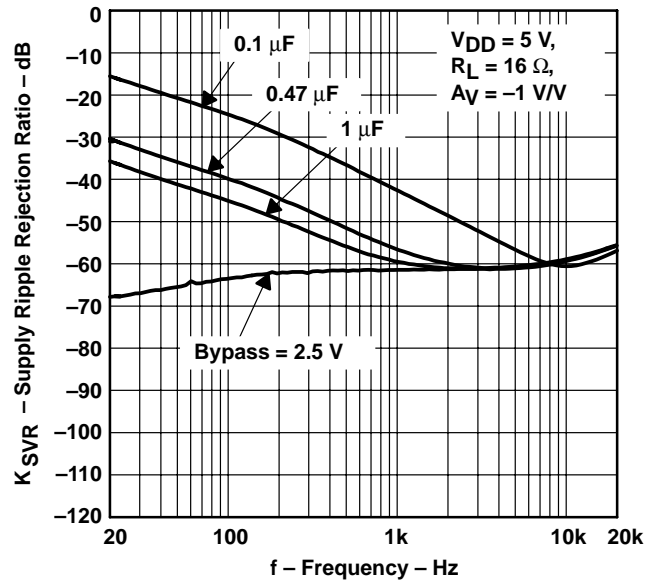

Figure 16



TYPICAL CHARACTERISTICS

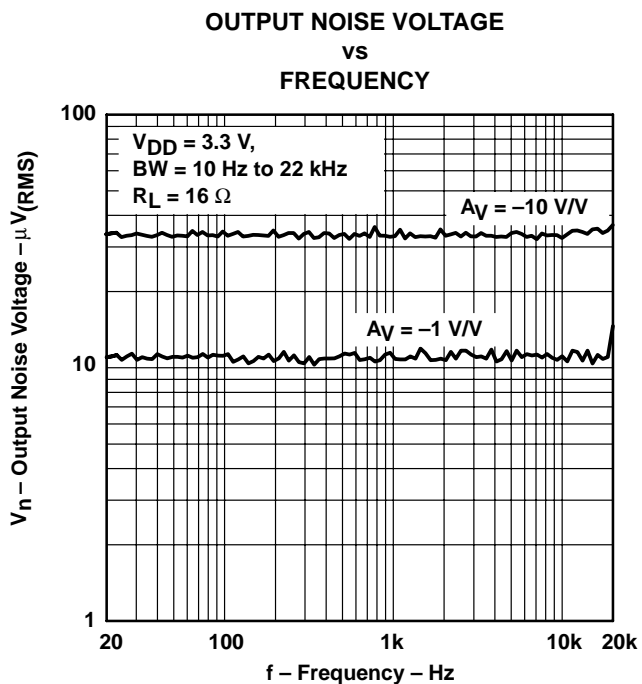

Figure 17

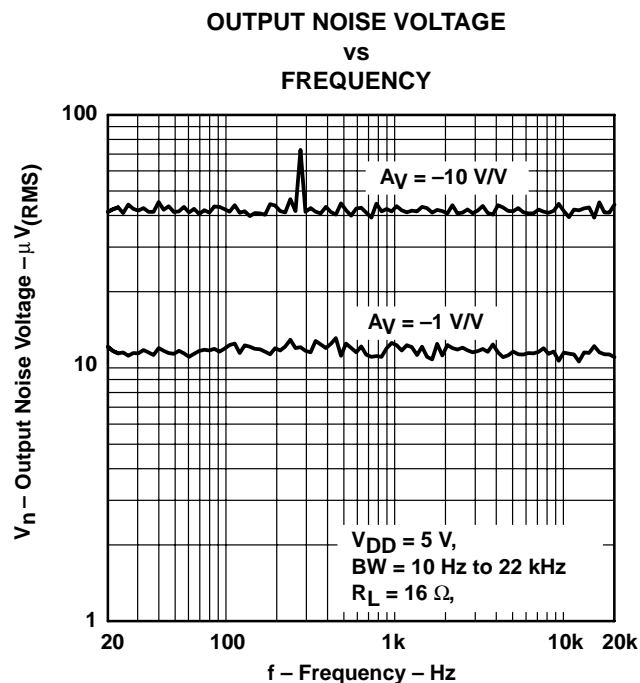

Figure 18

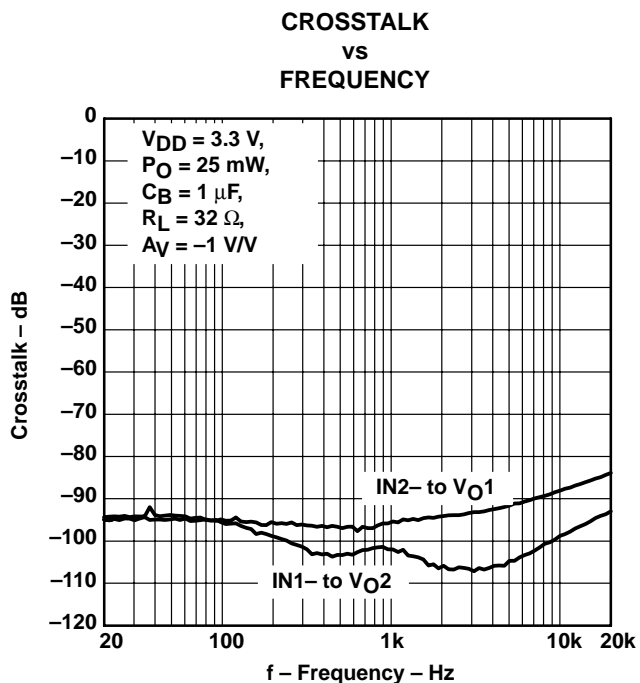

Figure 19

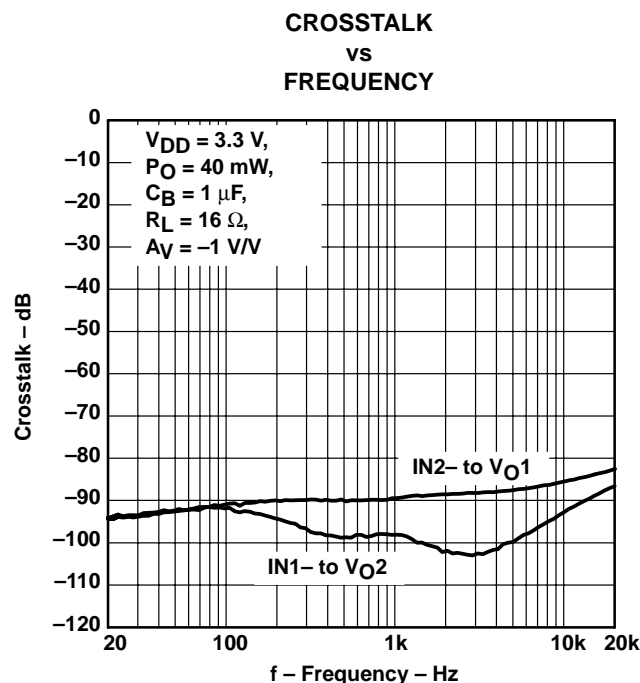

Figure 20

TPA6111A2 150-mW STEREO AUDIO POWER AMPLIFIER

SLOS313A – DECEMBER 2000 – REVISED OCTOBER 2002

TYPICAL CHARACTERISTICS

**CROSSTALK
vs
FREQUENCY**

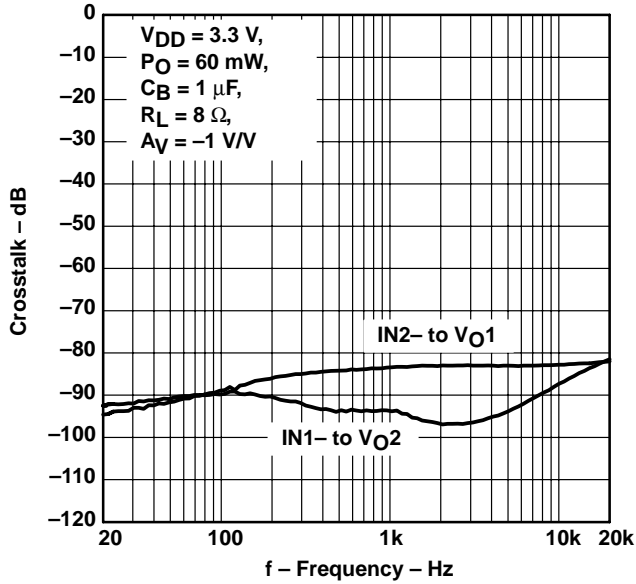

Figure 21

**CROSSTALK
vs
FREQUENCY**

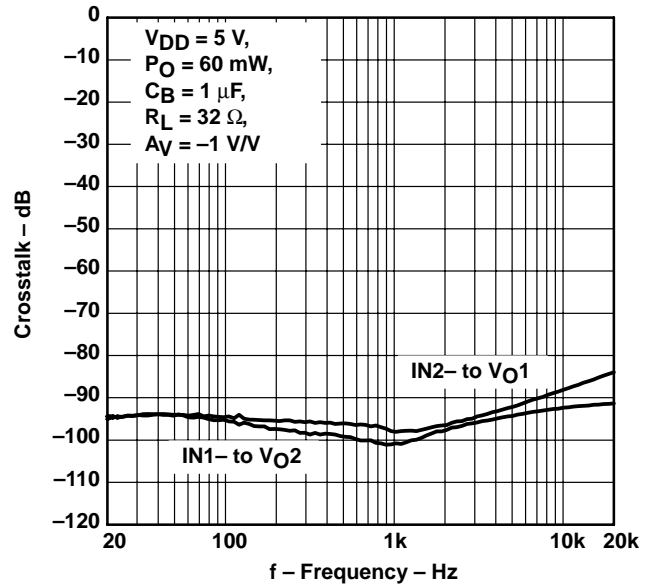

Figure 22

**CROSSTALK
vs
FREQUENCY**

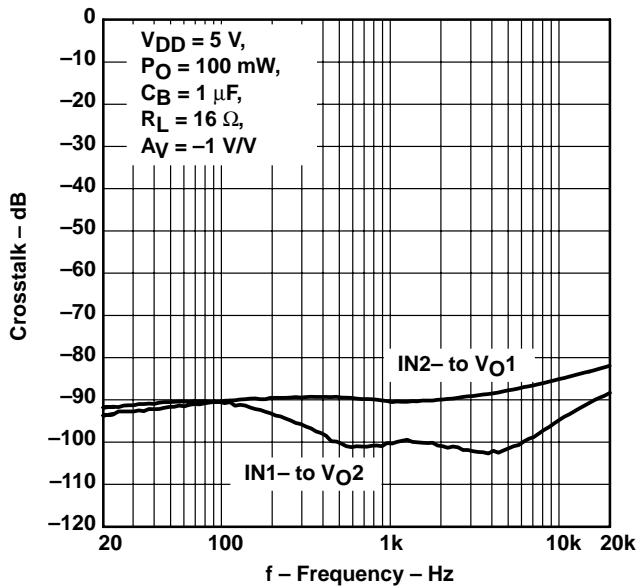

Figure 23

**CROSSTALK
vs
FREQUENCY**

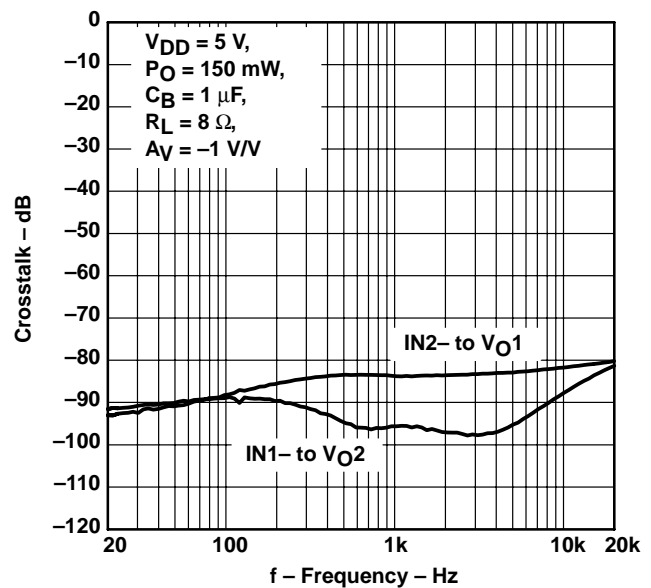

Figure 24

TYPICAL CHARACTERISTICS

SHUTDOWN ATTENUATION
VS
FREQUENCY

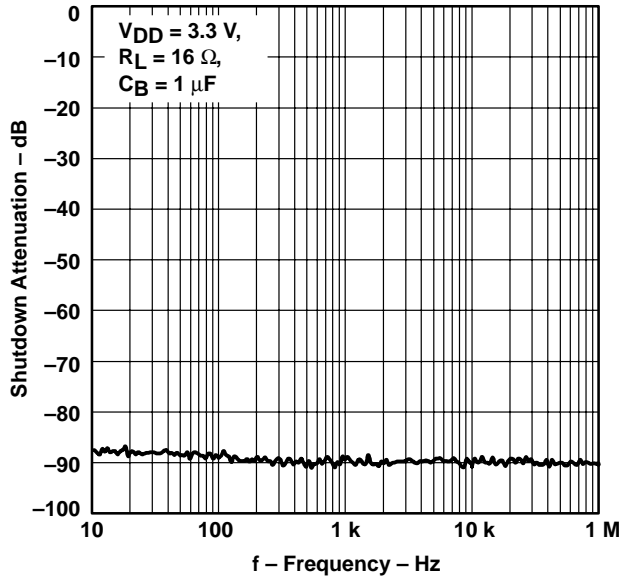

Figure 25

SHUTDOWN ATTENUATION
VS
FREQUENCY

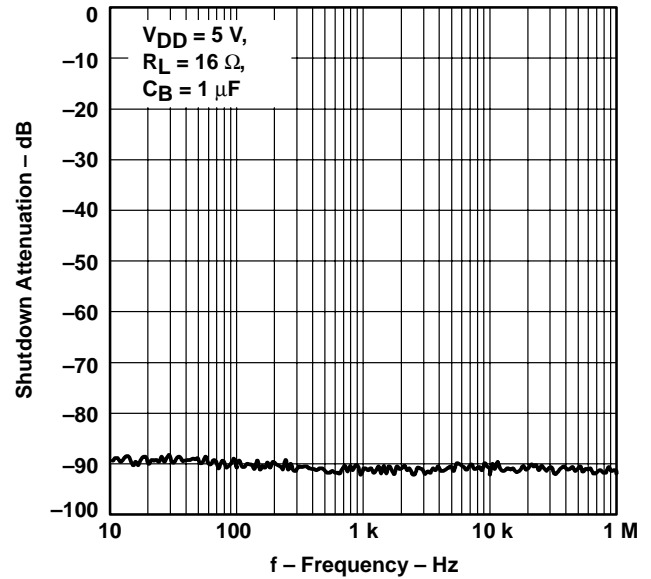

Figure 26

OPEN-LOOP GAIN AND PHASE MARGIN
VS
FREQUENCY

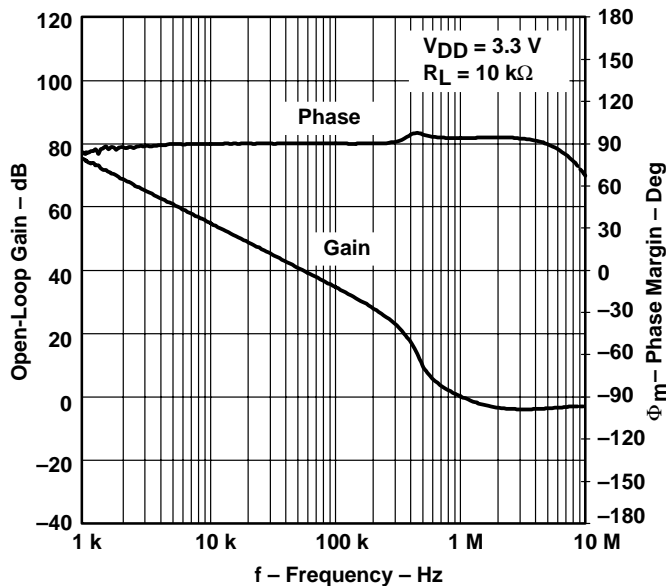

Figure 27

OPEN-LOOP GAIN AND PHASE MARGIN
VS
FREQUENCY

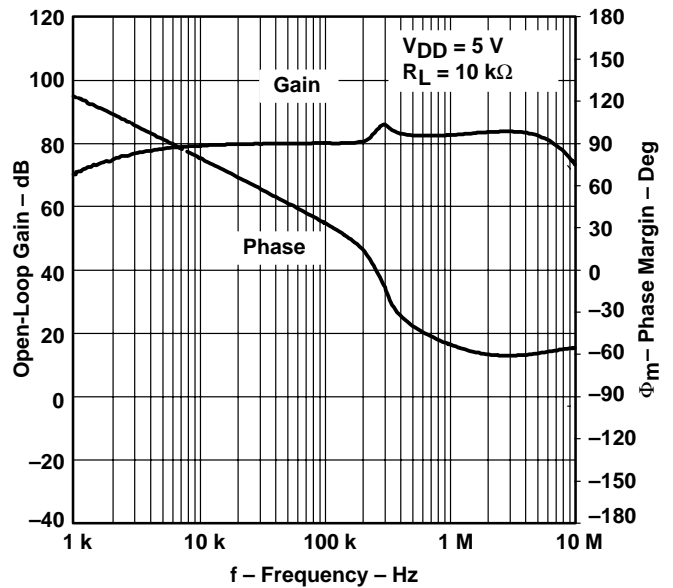

Figure 28

TPA6111A2 150-mW STEREO AUDIO POWER AMPLIFIER

SLOS313A – DECEMBER 2000 – REVISED OCTOBER 2002

TYPICAL CHARACTERISTICS

OUTPUT POWER
vs
LOAD RESISTANCE

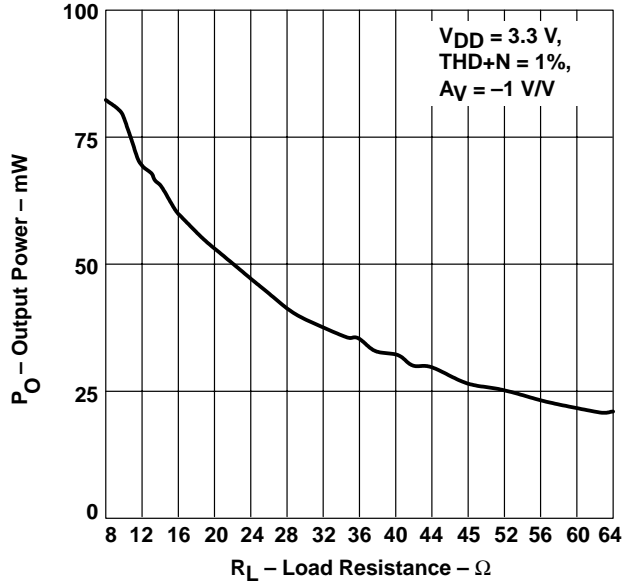

Figure 29

OUTPUT POWER
vs
LOAD RESISTANCE

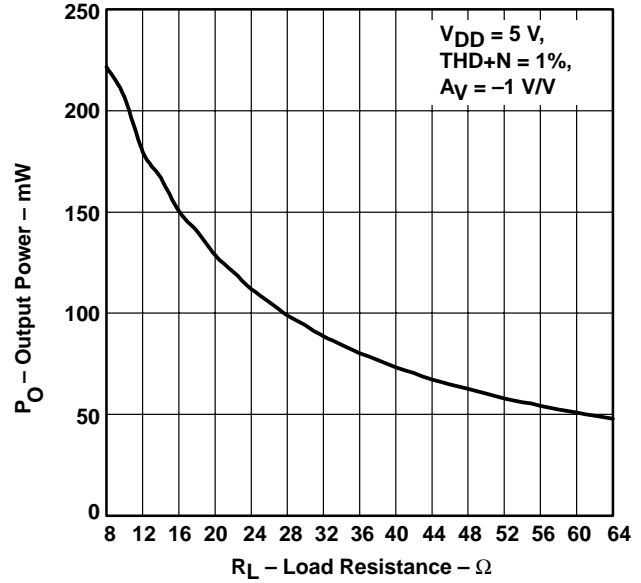

Figure 30

SUPPLY CURRENT
vs
SUPPLY VOLTAGE

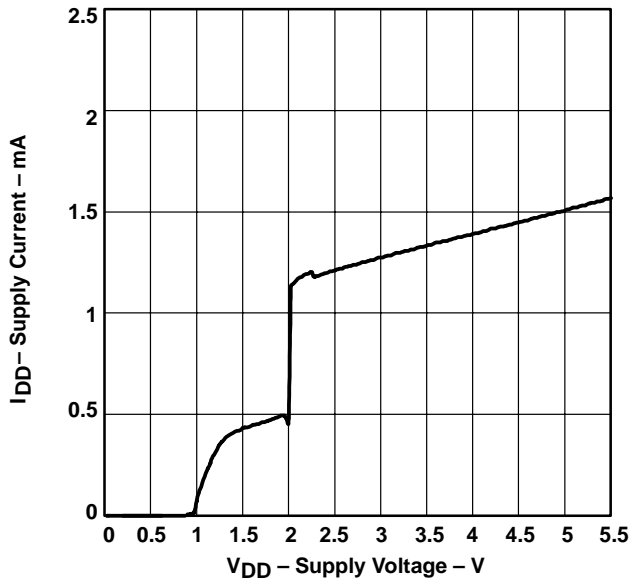

Figure 31

SIGNAL-TO-NOISE RATIO
vs
VOLTAGE GAIN

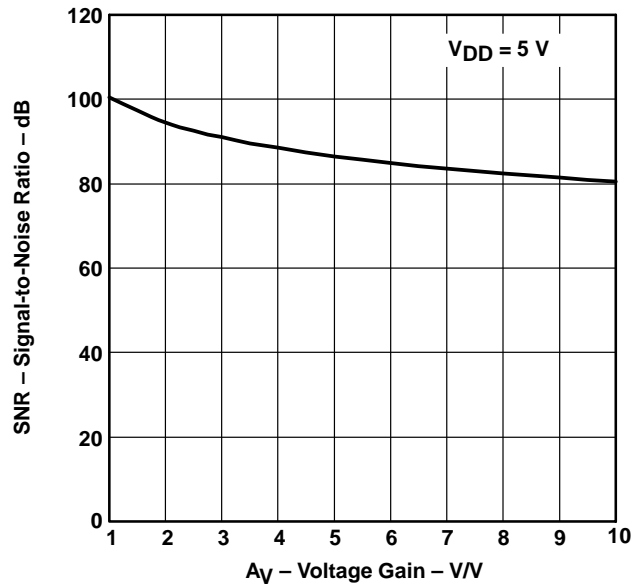

Figure 32

TYPICAL CHARACTERISTICS

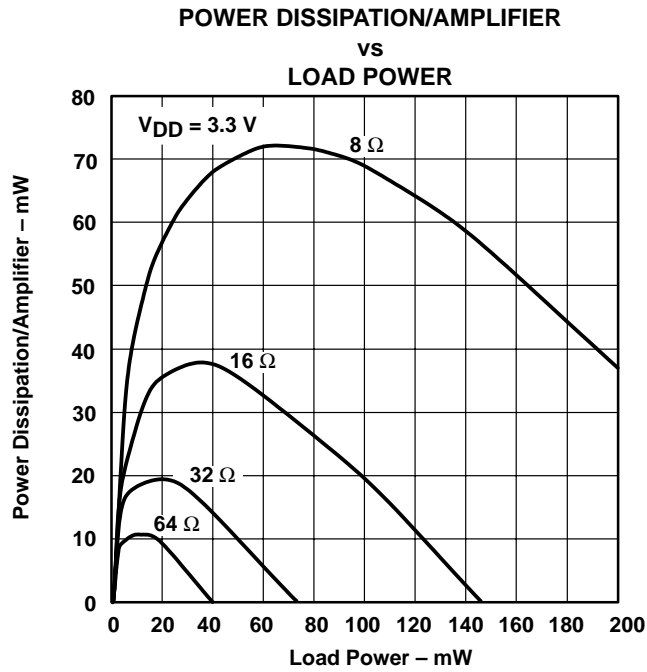

Figure 33

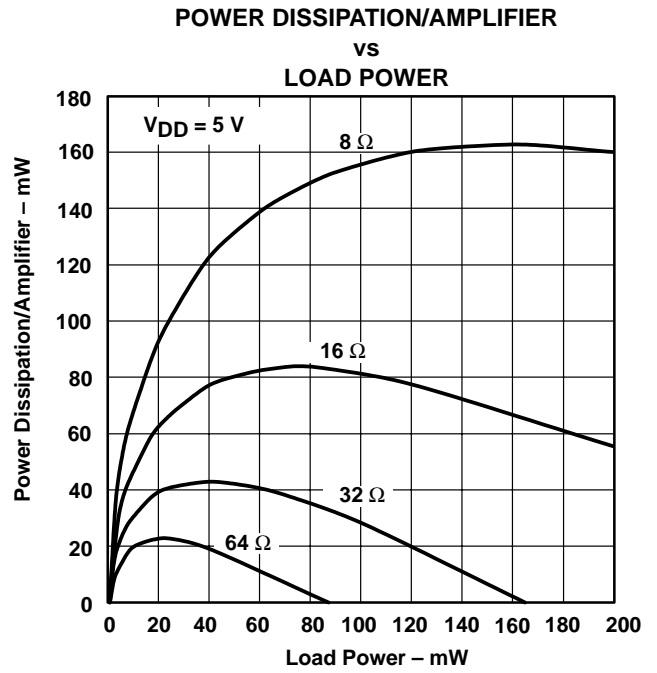

Figure 34

TPA6111A2

150-mW STEREO AUDIO POWER AMPLIFIER

SLOS313A – DECEMBER 2000 – REVISED OCTOBER 2002

APPLICATION INFORMATION

gain setting resistors, R_f and R_i

The gain for the TPA6111A2 is set by resistors R_f and R_i according to equation 1.

$$\text{Gain} = - \left(\frac{R_f}{R_i} \right) \quad (1)$$

Given that the TPA6111A2 is a MOS amplifier, the input impedance is very high. Consequently input leakage currents are not generally a concern, although noise in the circuit increases as the value of R_f increases. In addition, a certain range of R_f values is required for proper start-up operation of the amplifier. Taken together it is recommended that the effective impedance seen by the inverting node of the amplifier be set between 5 k Ω and 20 k Ω . The effective impedance is calculated in equation 2.

$$\text{Effective Impedance} = \frac{R_f R_i}{R_f + R_i} \quad (2)$$

As an example, consider an input resistance of 20 k Ω and a feedback resistor of 20 k Ω . The gain of the amplifier would be -1 and the effective impedance at the inverting terminal would be 10 k Ω , which is within the recommended range.

For high performance applications, metal film resistors are recommended because they tend to have lower noise levels than carbon resistors. For values of R_f above 50 k Ω , the amplifier tends to become unstable due to a pole formed from R_f and the inherent input capacitance of the MOS input structure. For this reason, a small compensation capacitor of approximately 5 pF should be placed in parallel with R_f . This, in effect, creates a low-pass filter network with the cutoff frequency defined in equation 3.

$$f_{c(\text{lowpass})} = \frac{1}{2\pi R_f C_F} \quad (3)$$

For example, if R_f is 100 k Ω and C_F is 5 pF then $f_{c(\text{lowpass})}$ is 318 kHz, which is well outside the audio range.

input capacitor, C_i

In the typical application, an input capacitor, C_i , is required to allow the amplifier to bias the input signal to the proper dc level for optimum operation. In this case, C_i and R_i form a high-pass filter with the corner frequency determined in equation 4.

$$f_{c(\text{highpass})} = \frac{1}{2\pi R_i C_i} \quad (4)$$

The value of C_i is important to consider, as it directly affects the bass (low frequency) performance of the circuit. Consider the example where R_i is 20 k Ω and the specification calls for a flat bass response down to 20 Hz. Equation 4 is reconfigured as equation 5.

$$C_i = \frac{1}{2\pi R_i f_{c(\text{highpass})}} \quad (5)$$

APPLICATION INFORMATION

input capacitor, C_i (continued)

In this example, C_i is 0.40 μF , so one would likely choose a value in the range of 0.47 μF to 1 μF . A further consideration for this capacitor is the leakage path from the input source through the input network (R_i , C_i) and the feedback resistor (R_f) to the load. This leakage current creates a dc offset voltage at the input to the amplifier that reduces useful headroom, especially in high-gain applications (> 10). For this reason a low-leakage tantalum or ceramic capacitor is the best choice. When polarized capacitors are used, the positive side of the capacitor should face the amplifier input in most applications, as the dc level there is held at $V_{DD}/2$, which is likely higher than the source dc level. Please note that it is important to confirm the capacitor polarity in the application.

power supply decoupling, $C(s)$

The TPA6111A2 is a high-performance CMOS audio amplifier that requires adequate power supply decoupling to ensure that the output total harmonic distortion (THD) is as low as possible. Power supply decoupling also prevents oscillations for long lead lengths between the amplifier and the speaker. The optimum decoupling is achieved by using two capacitors of different types that target different types of noise on the power supply leads. For higher frequency transients, spikes, or digital hash on the line, a good low equivalent-series-resistance (ESR) ceramic capacitor, typically 0.1 μF , placed as close as possible to the device V_{DD} lead, works best. For filtering lower-frequency noise signals, a larger aluminum electrolytic capacitor of 10 μF or greater placed near the power amplifier is recommended.

midrail bypass capacitor, $C_{(BYP)}$

The midrail bypass capacitor, $C_{(BYP)}$, serves several important functions. During start-up, $C_{(BYP)}$ determines the rate at which the amplifier starts up. This helps to push the start-up pop noise into the subaudible range (so low it can not be heard). The second function is to reduce noise produced by the power supply caused by coupling into the output drive signal. This noise is from the midrail generation circuit internal to the amplifier. The capacitor is fed from a 230-k Ω source inside the amplifier. To keep the start-up pop as low as possible, the relationship shown in equation 6 should be maintained.

$$\frac{1}{(C_{(BYP)} \times 230 \text{ k}\Omega)} \leq \frac{1}{(C_i R_i)} \quad (6)$$

As an example, consider a circuit where $C_{(BYP)}$ is 1 μF , C_i is 1 μF , and R_i is 20 k Ω . Inserting these values into the equation 9 results in: $6.25 \leq 50$ which satisfies the rule. Bypass capacitor, $C_{(BYP)}$, values of 0.1 μF to 1 μF ceramic or tantalum low-ESR capacitors are recommended for the best THD and noise performance.

output coupling capacitor, C_C

In the typical single-supply single-ended (SE) configuration, an output coupling capacitor (C_C) is required to block the dc bias at the output of the amplifier, thus preventing dc currents in the load. As with the input coupling capacitor, the output coupling capacitor and impedance of the load form a high-pass filter governed by equation 7.

$$f_c = \frac{1}{2\pi R_L C_C} \quad (7)$$

TPA6111A2

150-mW STEREO AUDIO POWER AMPLIFIER

SLOS313A – DECEMBER 2000 – REVISED OCTOBER 2002

APPLICATION INFORMATION

output coupling capacitor, C_C (continued)

The main disadvantage, from a performance standpoint, is that the typically small load impedances drive the low-frequency corner higher. Large values of C_C are required to pass low frequencies into the load. Consider the example where a C_C of 68 μF is chosen and loads vary from 32 Ω to 47 k Ω . Table 1 summarizes the frequency response characteristics of each configuration.

Table 1. Common Load Impedances vs Low Frequency Output Characteristics in SE Mode

| R_L | C_C | LOWEST FREQUENCY |
|-----------------|------------------|------------------|
| 32 Ω | 68 μF | 73 Hz |
| 10,000 Ω | 68 μF | 0.23 Hz |
| 47,000 Ω | 68 μF | 0.05 Hz |

As Table 1 indicates, headphone response is adequate and drive into line level inputs (a home stereo for example) is very good.

The output coupling capacitor required in single-supply SE mode also places additional constraints on the selection of other components in the amplifier circuit. With the rules described earlier still valid, add the following relationship:

$$\frac{1}{(C_{(BYP)} \times 230 \text{ k}\Omega)} \leq \frac{1}{(C_i R_i)} \ll \frac{1}{R_L C_C} \quad (8)$$

using low-ESR capacitors

Low-ESR capacitors are recommended throughout this application. A real capacitor can be modeled simply as a resistor in series with an ideal capacitor. The voltage drop across this resistor minimizes the beneficial effects of the capacitor in the circuit. The lower the equivalent value of this resistance, the more the real capacitor behaves like an ideal capacitor.

5-V versus 3.3-V operation

The TPA6111A2 was designed for operation over a supply range of 2.7 V to 5.5 V. This data sheet provides full specifications for 5-V and 3.3-V operation, since these are considered to be the two most common standard voltages. There are no special considerations for 3.3-V versus 5-V operation as far as supply bypassing, gain setting, or stability. Supply current is slightly reduced from 3.5 mA (typical) to 2.5 mA (typical). The most important consideration is that of output power. Each amplifier in the TPA6111A2 can produce a maximum voltage swing of $V_{DD} - 1$ V. This means, for 3.3-V operation, clipping starts to occur when $V_{O(PP)} = 2.3$ V as opposed when $V_{O(PP)} = 4$ V while operating at 5 V. The reduced voltage swing subsequently reduces maximum output power into the load before distortion begins to become significant.



MECHANICAL DATA

D (R-PDSO-G**)

PLASTIC SMALL-OUTLINE PACKAGE

14 PINS SHOWN

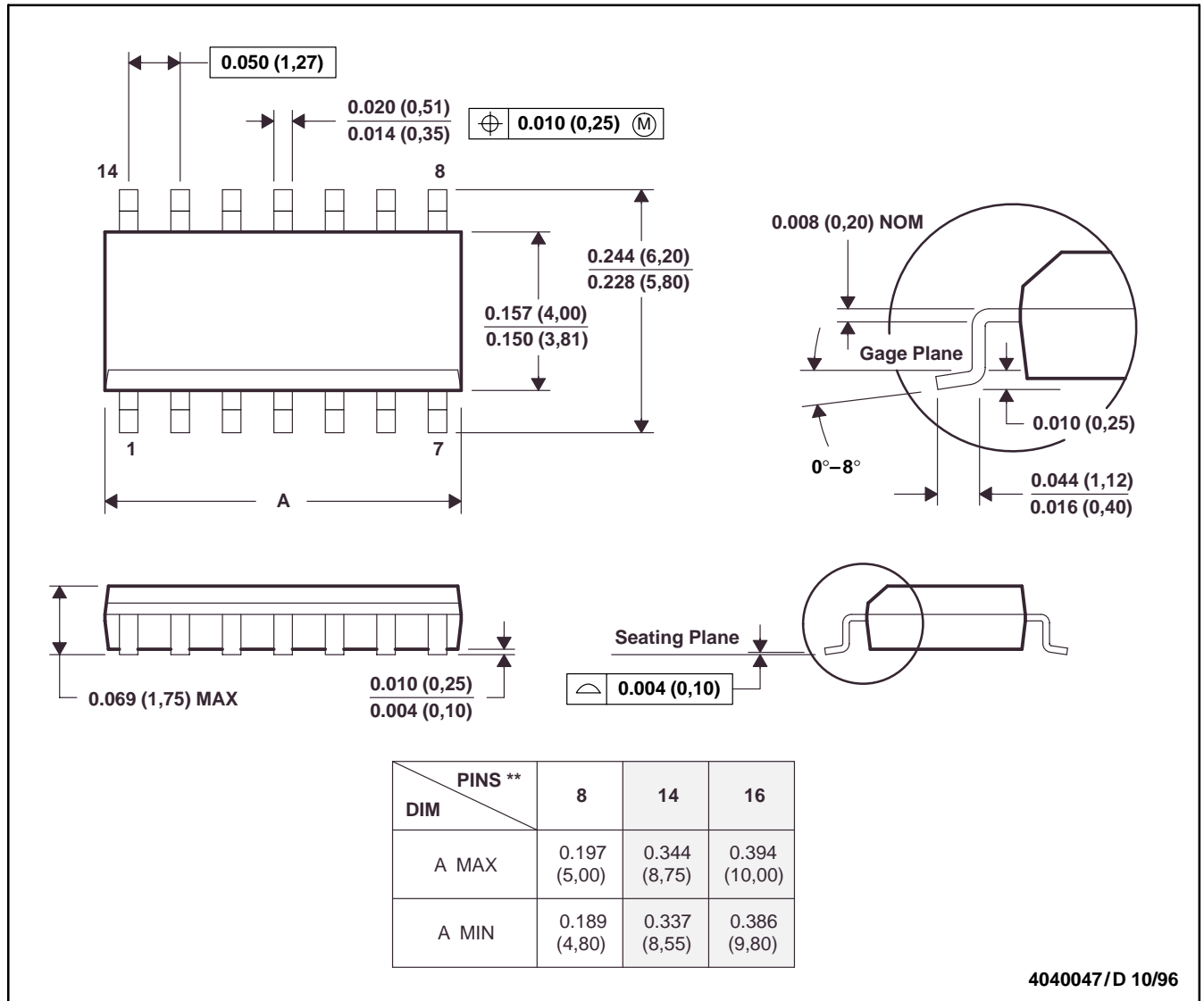

- NOTES: A. All linear dimensions are in inches (millimeters).
 B. This drawing is subject to change without notice.
 C. Body dimensions do not include mold flash or protrusion, not to exceed 0.006 (0,15).
 D. Falls within JEDEC MS-012

TPA6111A2 150-mW STEREO AUDIO POWER AMPLIFIER

SLOS313A – DECEMBER 2000 – REVISED OCTOBER 2002

MECHANICAL DATA

DGN (S-PDSO-G8)

PowerPAD™ PLASTIC SMALL-OUTLINE PACKAGE

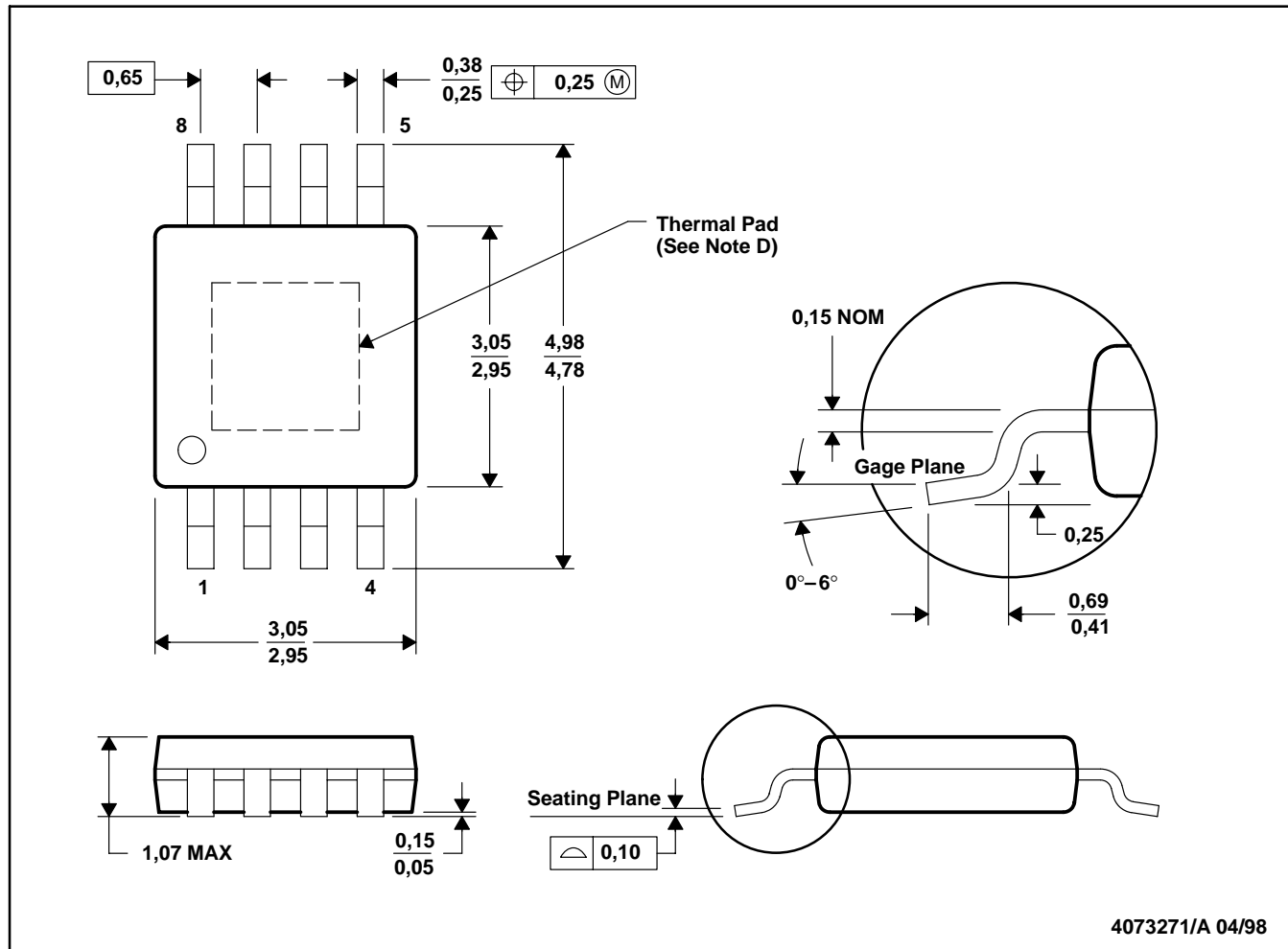

- NOTES: A. All linear dimensions are in millimeters.
 B. This drawing is subject to change without notice.
 C. Body dimensions include mold flash or protrusions.
 D. The package thermal performance may be enhanced by attaching an external heat sink to the thermal pad. This pad is electrically and thermally connected to the backside of the die and possibly selected leads.
 E. Falls within JEDEC MO-187

PowerPAD is a trademark of Texas Instruments.



POST OFFICE BOX 655303 • DALLAS, TEXAS 75265

IMPORTANT NOTICE

Texas Instruments Incorporated and its subsidiaries (TI) reserve the right to make corrections, modifications, enhancements, improvements, and other changes to its products and services at any time and to discontinue any product or service without notice. Customers should obtain the latest relevant information before placing orders and should verify that such information is current and complete. All products are sold subject to TI's terms and conditions of sale supplied at the time of order acknowledgment.

TI warrants performance of its hardware products to the specifications applicable at the time of sale in accordance with TI's standard warranty. Testing and other quality control techniques are used to the extent TI deems necessary to support this warranty. Except where mandated by government requirements, testing of all parameters of each product is not necessarily performed.

TI assumes no liability for applications assistance or customer product design. Customers are responsible for their products and applications using TI components. To minimize the risks associated with customer products and applications, customers should provide adequate design and operating safeguards.

TI does not warrant or represent that any license, either express or implied, is granted under any TI patent right, copyright, mask work right, or other TI intellectual property right relating to any combination, machine, or process in which TI products or services are used. Information published by TI regarding third-party products or services does not constitute a license from TI to use such products or services or a warranty or endorsement thereof. Use of such information may require a license from a third party under the patents or other intellectual property of the third party, or a license from TI under the patents or other intellectual property of TI.

Reproduction of information in TI data books or data sheets is permissible only if reproduction is without alteration and is accompanied by all associated warranties, conditions, limitations, and notices. Reproduction of this information with alteration is an unfair and deceptive business practice. TI is not responsible or liable for such altered documentation.

Resale of TI products or services with statements different from or beyond the parameters stated by TI for that product or service voids all express and any implied warranties for the associated TI product or service and is an unfair and deceptive business practice. TI is not responsible or liable for any such statements.

Mailing Address:

Texas Instruments
Post Office Box 655303
Dallas, Texas 75265