

Octal Line Receiver

FEATURES

- Meets EIA 232E/423A/422A and CCITT V.10,V.11, V.28, X.26, X.27
- Single +5V Supply--TTL Compatible Outputs
- Differential Inputs Withstand $\pm 25V$
- Low Open Circuit Voltage for Improved Failsafe Characteristic
- Reduced Supply Current--35 mA Max
- Input Noise Filter
- Internal Hysteresis

DESCRIPTION

The UC5180C is an octal line receiver designed to meet a wide range of digital communications requirements as outlined in EIA standards EIA232E, EIA423A, EIA422A, and CCITT V.10, V.11, V.28, X.26, and X.27. The UC5180C includes an input noise filter and is intended for applications employing data rates up to 200 KBPS. A failsafe function allows these devices to "fail" to a known state under a wide variety of fault conditions at the inputs.

ABSOLUTE MAXIMUM RATINGS (Note 1)

Supply Voltage, Vcc	7V
Output Sink Current	50 mA
Output Short Circuit Time	1 Sec
Common Mode Input Range	15V
Differential Input Range	25V
Failsafe Voltage	-0.3 to Vcc
PLCC Power Dissipation, TA = 25°C (Note 2)	1000 mW
DIP Power Dissipation, TA = 25°C (Note 2)	1200 mW
Storage Temperature Range	-65°C to +150°C
Lead Temperature (Soldering, 10 Seconds)	-300°C

Note 1: All voltages are with respect to ground, pin 14. Currents are positive into, negative out of the specified terminal

Note 2: Consult Packaging Section of Databook for thermal limitations and considerations of package.

CONNECTION DIAGRAMS

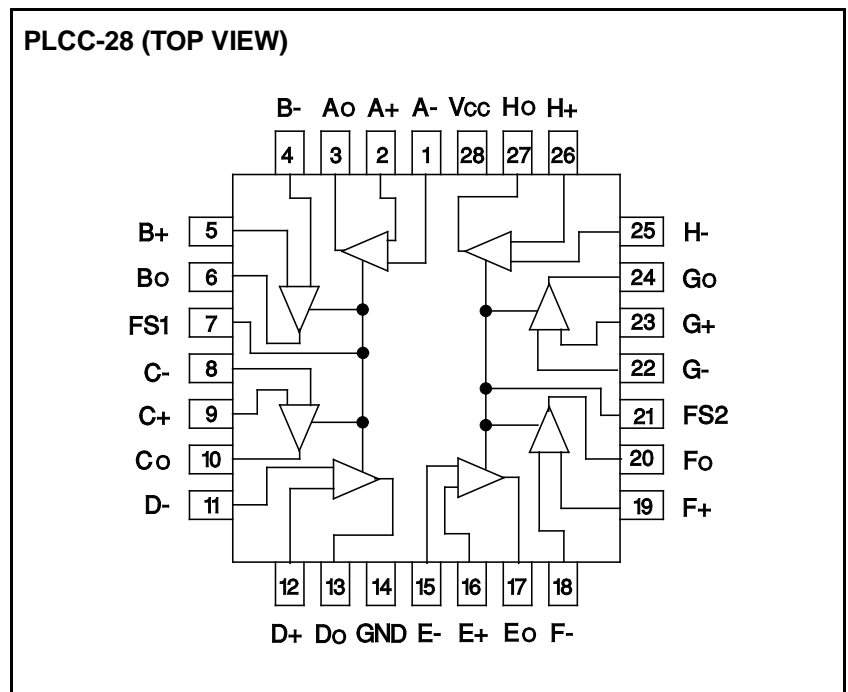
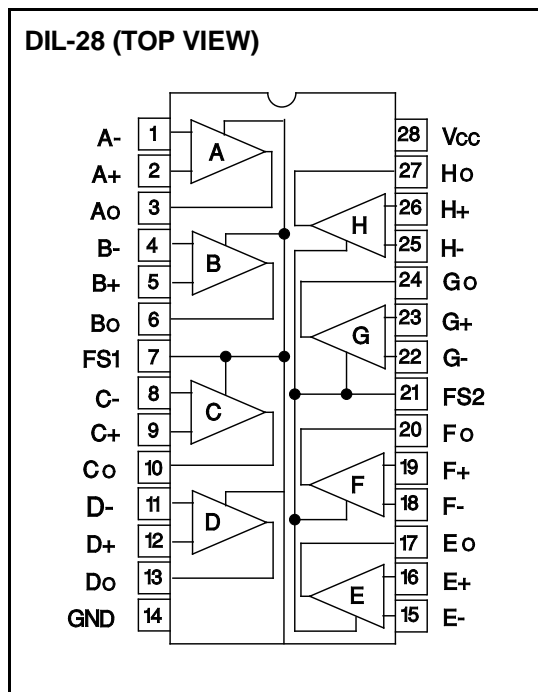

DC ELECTRICAL CHARACTERISTICS: Unless otherwise stated these specifications apply for $T_A = 0^\circ\text{C}$ to $+70^\circ\text{C}$, $V_{CC} = 5\text{V} \pm 5\%$, Input Common Mode Range $\pm 7\text{V}$, $T_A = T_J$

PARAMETERS	SYMBOL	TEST CONDITIONS	UC5180C		UNITS	
			MIN	MAX		
DC Input Resistance	R_{IN}	$3\text{V} \leq V_{IN} \leq 25\text{V}$	3	7	$\text{k}\Omega$	
Failsafe Output Voltage	V_{OFS}	Inputs Open or Shorted Together, or One Input Open and One Grounded	$0 \leq I_{OUT} \leq 8\text{mA}$, $V_{FAILSAFE} = 0\text{V}$	0.45	V	
			$0 \geq I_{OUT} \geq -400\ \mu\text{A}$, $V_{FAILSAFE} = V_{CC}$	2.7		
Differential Input High Threshold	V_{TH}	$V_{OUT} = 2.7\text{V}$, $I_{OUT} = 440\ \mu\text{A}$ (See Figure 1)	$R_s = 0$ (Note 2)	50	200	mV
			$R_s = 500$ (Note 2)		400	
Differential Input Low Threshold	V_{TL}	$V_{OUT} = 0.45\text{V}$, $I_{OUT} = 440\ \mu\text{A}$ (See Figure 1)	$R_s = 0$ (Note 2)	-200	-50	mV
			$R_s = 500$ (Note 2)	-400		
Hysteresis	V_H	$F_s = 0\text{V}$ or V_{CC} (See Figure 1)	50	140	mV	
Open Circuit Input Voltage	V_{ICC}			75	mV	
Input Capacitance	C_i			20	pF	
High Level Output Voltage	V_{CH}	$V_{ID} = 1\text{V}$, $I_{OUT} = -440\ \mu\text{A}$	2.7		V	
Low Level Output Voltage	V_{OL}	$V_{ID} = -1\text{V}$ (Note 3)	$I_{OUT} = 4\ \text{mA}$		0.4	V
			$I_{OUT} = 8\ \text{mA}$		0.45	
Short Circuit Output Current	I_{OS}	Note 4	20	100	mA	
Supply Current	I_{CC}	$4.75\text{V} \leq V_{CC} \leq 5.25\text{V}$		35	mA	
Input Current	I_{IN}	Other Inputs Grounded	$V_{IN} = +10\text{V}$		3.25	mA
			$V_{IN} = -10\text{V}$	-3.25		

Note 2: R_s is a resistor in series with each input.

Note 3: Measured after 100ms warm up (at 0°C)

Note 4: Only 1 output may be shorted at one time and then only for a maximum of 1 sec.

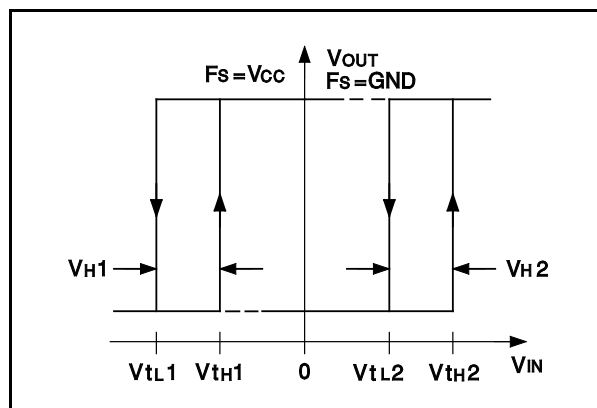

Figure 1. V_{tL} , V_{tH} , V_H Definition

AC ELECTRICAL CHARACTERISTICS: $V_{CC} = 5\text{V} \pm 5\%$, $T_A = 0^\circ\text{C}$ to $+70^\circ\text{C}$, Figure 2, $T_A = T_J$.

PARAMETERS	SYMBOL	TEST CONDITIONS	UC5180C		UNITS
			MIN	MAX	
Propagation Delay - Low to High	t_{PLH}	$C_L = 50\text{pF}$, $V_{IN} = \pm 500\text{mV}$		550	ns
Propagation Delay - High to Low	t_{PHL}	$C_L = 50\text{pF}$, $V_{IN} = \pm 500\text{mV}$		550	ns
Acceptance Input Frequency	f_A	Unused Input Grounded, $V_{IN} = \pm 200\text{mV}$		0.1	MHz
Rejectable Input Frequency	f_R	Unused Input Grounded, $V_{IN} = \pm 500\text{mV}$	5.5		MHz

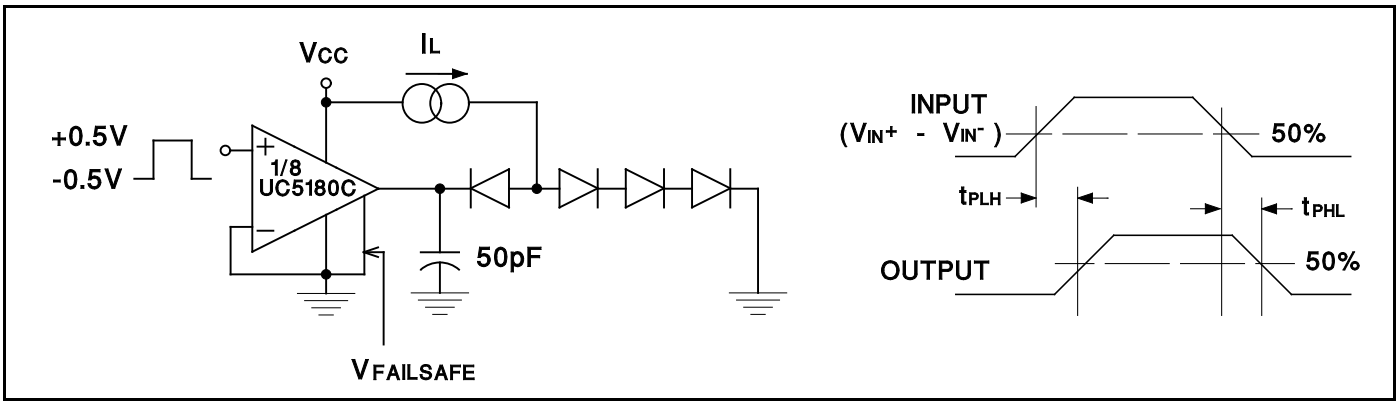

Figure 2. AC Test Circuit

APPLICATIONS INFORMATION

Failsafe Operation

These devices provide a failsafe operating mode to guard against input fault conditions as defined in EIA422A and EIA423A standards. These fault conditions are (1) drive in power-off condition, (2) receiver not interconnected with driver, (3) open-circuited interconnecting cable, and (4) short-circuited interconnecting cable. If one of these four fault conditions occurs at the inputs of a receiver, then the output of that receiver is driven to a known logic level. The receiver is programmed by connecting the failsafe input to Vcc or ground. A connection to Vcc provides a logic "1" output

under fault conditions, while a connection to ground provides a logic "0". There are two failsafe pins (Fs1 and Fs2) on the UC5180C where each provides common failsafe control for four receivers.

Input Filtering (UC5180C)

The UC5180C has input filtering for additional noise rejection. This filtering is a function of both signal level and frequency. For the specified input (5.5 MHz at ±500 mV) the input stage filter attenuates the signal such that the output stage threshold levels are not exceeded and no change of state occurs at the output.

EIA232E/V.28 / EIA423A/V.10 DATA TRANSMISSION

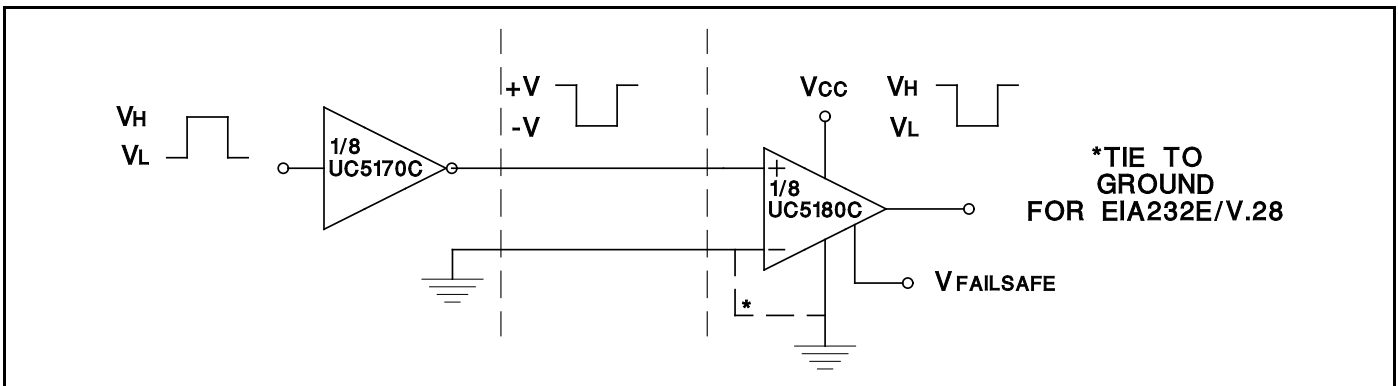

EIA422A/V.11 DATA TRANSMISSION

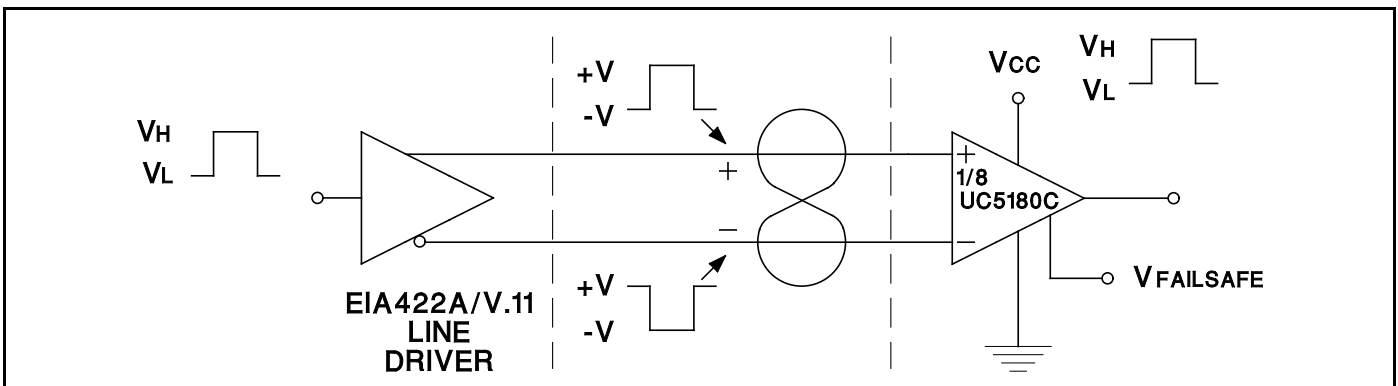

PACKAGING INFORMATION

Orderable Device	Status ⁽¹⁾	Package Type	Package Drawing	Pins	Package Qty	Eco Plan ⁽²⁾	Lead/Ball Finish	MSL Peak Temp ⁽³⁾
UC5180CJ	OBSOLETE		UTR			None	Call TI	Call TI
UC5180CN	ACTIVE	PDIP	N	28	13	None	CU SNPB	Level-NA-NA-NA
UC5180CQ	ACTIVE	PLCC	FN	28	37	None	CU SNPB	Level-2-220C-1 YEAR
UC5180CQTR	ACTIVE	PLCC	FN	28	750	None	CU SNPB	Level-2-220C-1 YEAR

⁽¹⁾ The marketing status values are defined as follows:

ACTIVE: Product device recommended for new designs.

LIFEBUY: TI has announced that the device will be discontinued, and a lifetime-buy period is in effect.

NRND: Not recommended for new designs. Device is in production to support existing customers, but TI does not recommend using this part in a new design.

PREVIEW: Device has been announced but is not in production. Samples may or may not be available.

OBSOLETE: TI has discontinued the production of the device.

⁽²⁾ Eco Plan - May not be currently available - please check <http://www.ti.com/productcontent> for the latest availability information and additional product content details.

None: Not yet available Lead (Pb-Free).

Pb-Free (RoHS): TI's terms "Lead-Free" or "Pb-Free" mean semiconductor products that are compatible with the current RoHS requirements for all 6 substances, including the requirement that lead not exceed 0.1% by weight in homogeneous materials. Where designed to be soldered at high temperatures, TI Pb-Free products are suitable for use in specified lead-free processes.

Green (RoHS & no Sb/Br): TI defines "Green" to mean "Pb-Free" and in addition, uses package materials that do not contain halogens, including bromine (Br) or antimony (Sb) above 0.1% of total product weight.

⁽³⁾ MSL, Peak Temp. -- The Moisture Sensitivity Level rating according to the JEDEC industry standard classifications, and peak solder temperature.

Important Information and Disclaimer:The information provided on this page represents TI's knowledge and belief as of the date that it is provided. TI bases its knowledge and belief on information provided by third parties, and makes no representation or warranty as to the accuracy of such information. Efforts are underway to better integrate information from third parties. TI has taken and continues to take reasonable steps to provide representative and accurate information but may not have conducted destructive testing or chemical analysis on incoming materials and chemicals. TI and TI suppliers consider certain information to be proprietary, and thus CAS numbers and other limited information may not be available for release.

In no event shall TI's liability arising out of such information exceed the total purchase price of the TI part(s) at issue in this document sold by TI to Customer on an annual basis.

IMPORTANT NOTICE

Texas Instruments Incorporated and its subsidiaries (TI) reserve the right to make corrections, modifications, enhancements, improvements, and other changes to its products and services at any time and to discontinue any product or service without notice. Customers should obtain the latest relevant information before placing orders and should verify that such information is current and complete. All products are sold subject to TI's terms and conditions of sale supplied at the time of order acknowledgment.

TI warrants performance of its hardware products to the specifications applicable at the time of sale in accordance with TI's standard warranty. Testing and other quality control techniques are used to the extent TI deems necessary to support this warranty. Except where mandated by government requirements, testing of all parameters of each product is not necessarily performed.

TI assumes no liability for applications assistance or customer product design. Customers are responsible for their products and applications using TI components. To minimize the risks associated with customer products and applications, customers should provide adequate design and operating safeguards.

TI does not warrant or represent that any license, either express or implied, is granted under any TI patent right, copyright, mask work right, or other TI intellectual property right relating to any combination, machine, or process in which TI products or services are used. Information published by TI regarding third-party products or services does not constitute a license from TI to use such products or services or a warranty or endorsement thereof. Use of such information may require a license from a third party under the patents or other intellectual property of the third party, or a license from TI under the patents or other intellectual property of TI.

Reproduction of information in TI data books or data sheets is permissible only if reproduction is without alteration and is accompanied by all associated warranties, conditions, limitations, and notices. Reproduction of this information with alteration is an unfair and deceptive business practice. TI is not responsible or liable for such altered documentation.

Resale of TI products or services with statements different from or beyond the parameters stated by TI for that product or service voids all express and any implied warranties for the associated TI product or service and is an unfair and deceptive business practice. TI is not responsible or liable for any such statements.

Following are URLs where you can obtain information on other Texas Instruments products and application solutions:

Products		Applications	
Amplifiers	amplifier.ti.com	Audio	www.ti.com/audio
Data Converters	dataconverter.ti.com	Automotive	www.ti.com/automotive
DSP	dsp.ti.com	Broadband	www.ti.com/broadband
Interface	interface.ti.com	Digital Control	www.ti.com/digitalcontrol
Logic	logic.ti.com	Military	www.ti.com/military
Power Mgmt	power.ti.com	Optical Networking	www.ti.com/opticalnetwork
Microcontrollers	microcontroller.ti.com	Security	www.ti.com/security
		Telephony	www.ti.com/telephony
		Video & Imaging	www.ti.com/video
		Wireless	www.ti.com/wireless

Mailing Address: Texas Instruments
Post Office Box 655303 Dallas, Texas 75265