

# 74VCX16240

## Low-Voltage 1.8/2.5/3.3V 16-Bit Buffer With 3.6 V-Tolerant Inputs and Outputs (3-State, Inverting)

The 74VCX16240 is an advanced performance, inverting 16-bit buffer. It is designed for very high-speed, very low-power operation in 1.8 V, 2.5 V or 3.3 V systems.

When operating at 2.5 V (or 1.8 V) the part is designed to tolerate voltages it may encounter on either inputs or outputs when interfacing to 3.3 V busses. It is guaranteed to be over-voltage tolerant to 3.6 V.

The 74VCX16240 is nibble controlled with each nibble functioning identically, but independently. The control pins may be tied together to obtain full 16-bit operation. The 3-state outputs are controlled by an Output Enable ( $\overline{OEn}$ ) input for each nibble. When  $\overline{OEn}$  is LOW, the outputs are on. When  $\overline{OEn}$  is HIGH, the outputs are in the high impedance state.

- Designed for Low Voltage Operation:  $V_{CC} = 1.65\text{--}3.6\text{ V}$
- 3.6V Tolerant Inputs and Outputs
- High Speed Operation: 2.5 ns max for 3.0 to 3.6 V  
3.0 ns max for 2.3 to 2.7 V  
6.0 ns max for 1.65 to 1.95 V
- Static Drive:  $\pm 24\text{ mA}$  Drive at 3.0 V  
 $\pm 18\text{ mA}$  Drive at 2.3 V  
 $\pm 6\text{ mA}$  Drive at 1.65 V
- Supports Live Insertion and Withdrawal
- $I_{OFF}$  Specification Guarantees High Impedance When  $V_{CC} = 0\text{ V}$
- Near Zero Static Supply Current in All Three Logic States (20  $\mu\text{A}$ )  
Substantially Reduces System Power Requirements
- Latchup Performance Exceeds  $\pm 250\text{ mA}$  @ 125°C
- ESD Performance: Human Body Model >2000 V; Machine Model >200 V



ON Semiconductor

<http://onsemi.com>

### MARKING DIAGRAM

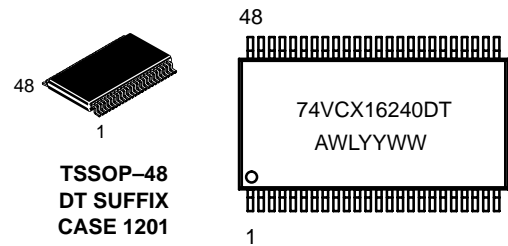

A = Assembly Location  
WL = Wafer Lot  
YY = Year  
WW = Work Week

### ORDERING INFORMATION

Device	Package	Shipping
74VCX16240DT	TSSOP	39 / Rail
74VCX16240DTR	TSSOP	2500 / Reel

# 74VCX16240

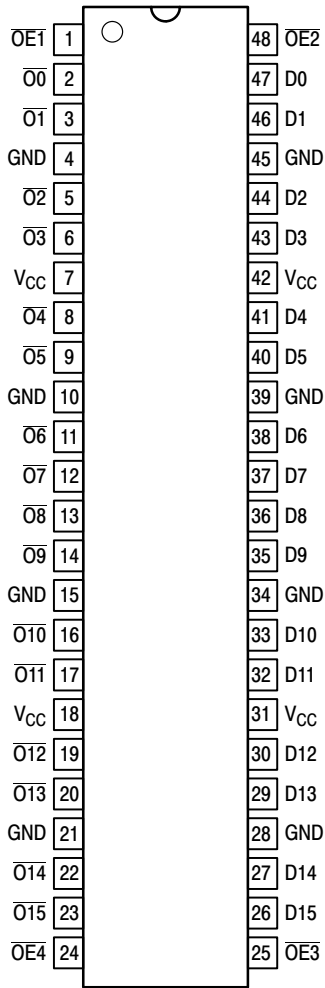

**Figure 1. 48-Lead Pinout**  
(Top View)

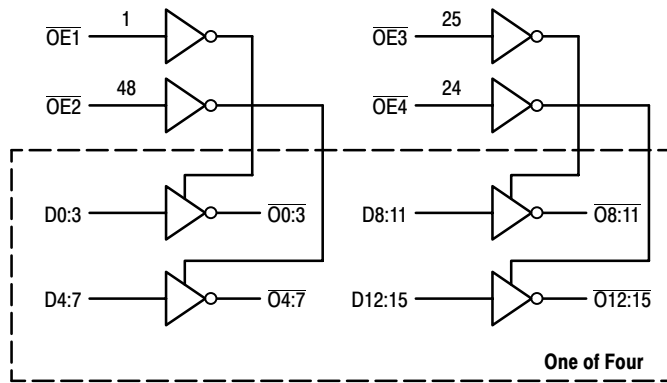

**Figure 2. Logic Diagram**

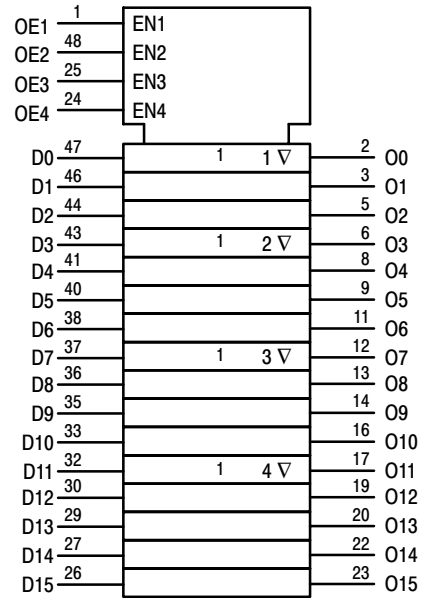

**Figure 3. IEC Logic Diagram**

## PIN NAMES

Pins	Function
OE <sub>n</sub>	Output Enable Inputs
D0–D15	Inputs
O0–O15	Outputs

OE1	D0:3	O0:3	OE2	D4:7	O4:7	OE3	D8:11	O8:11	OE4	D12:15	O12:15
L	L	H	L	L	H	L	L	H	L	L	H
L	H	L	L	H	L	L	H	L	L	H	L
H	X	Z	H	X	Z	H	X	Z	H	X	Z

H = High Voltage Level; L = Low Voltage Level; Z = High Impedance State; X = High or Low Voltage Level and Transitions Are Acceptable, for I<sub>CC</sub> reasons, DO NOT FLOAT Inputs

# 74VCX16240

## ABSOLUTE MAXIMUM RATINGS\*

Symbol	Parameter	Value	Condition	Unit
$V_{CC}$	DC Supply Voltage	-0.5 to +4.6		V
$V_I$	DC Input Voltage	$-0.5 \leq V_I \leq +4.6$		V
$V_O$	DC Output Voltage	$-0.5 \leq V_O \leq +4.6$	Output in 3-State	V
		$-0.5 \leq V_O \leq V_{CC} + 0.5$	Note 1.; Outputs Active	V
$I_{IK}$	DC Input Diode Current	-50	$V_I < GND$	mA
$I_{OK}$	DC Output Diode Current	-50	$V_O < GND$	mA
		+50	$V_O > V_{CC}$	mA
$I_O$	DC Output Source/Sink Current	$\pm 50$		mA
$I_{CC}$	DC Supply Current Per Supply Pin	$\pm 100$		mA
$I_{GND}$	DC Ground Current Per Ground Pin	$\pm 100$		mA
$T_{STG}$	Storage Temperature Range	-65 to +150		°C

\* Absolute maximum continuous ratings are those values beyond which damage to the device may occur. Exposure to these conditions or conditions beyond those indicated may adversely affect device reliability. Functional operation under absolute-maximum-rated conditions is not implied.

1.  $I_O$  absolute maximum rating must be observed.

## RECOMMENDED OPERATING CONDITIONS

Symbol	Parameter	Min	Typ	Max	Unit	
$V_{CC}$	Supply Voltage	Operating	1.65	3.3	3.6	V
		Data Retention Only	1.2	3.3	3.6	
$V_I$	Input Voltage	-0.3		3.6	V	
$V_O$	Output Voltage	(Active State)	0		$V_{CC}$	V
		(3-State)	0		3.6	
$I_{OH}$	HIGH Level Output Current, $V_{CC} = 3.0V - 3.6V$			-24	mA	
$I_{OL}$	LOW Level Output Current, $V_{CC} = 3.0V - 3.6V$			24	mA	
$I_{OH}$	HIGH Level Output Current, $V_{CC} = 2.3V - 2.7V$			-18	mA	
$I_{OL}$	LOW Level Output Current, $V_{CC} = 2.3V - 2.7V$			18	mA	
$I_{OH}$	HIGH Level Output Current, $V_{CC} = 1.65 - 1.95V$			-6	mA	
$I_{OL}$	LOW Level Output Current, $V_{CC} = 1.65 - 1.95V$			6	mA	
$T_A$	Operating Free-Air Temperature	-40		+85	°C	
$\Delta t/\Delta V$	Input Transition Rise or Fall Rate, $V_{IN}$ from 0.8V to 2.0V, $V_{CC} = 3.0V$	0		10	ns/V	

# 74VCX16240

## DC ELECTRICAL CHARACTERISTICS

Symbol	Characteristic	Condition	T <sub>A</sub> = -40°C to +85°C		Unit
			Min	Max	
V <sub>IH</sub>	HIGH Level Input Voltage (Note 2.)	1.65V ≤ V <sub>CC</sub> < 2.3V	0.65 x V <sub>CC</sub>		V
		2.3V ≤ V <sub>CC</sub> ≤ 2.7V	1.6		
		2.7V < V <sub>CC</sub> ≤ 3.6V	2.0		
V <sub>IL</sub>	LOW Level Input Voltage (Note 2.)	1.65V ≤ V <sub>CC</sub> < 2.3V		0.35 x V <sub>CC</sub>	V
		2.3V ≤ V <sub>CC</sub> ≤ 2.7V		0.7	
		2.7V < V <sub>CC</sub> ≤ 3.6V		0.8	
V <sub>OH</sub>	HIGH Level Output Voltage	1.65V ≤ V <sub>CC</sub> ≤ 3.6V; I <sub>OH</sub> = -100μA	V <sub>CC</sub> - 0.2		V
		V <sub>CC</sub> = 1.65V; I <sub>OH</sub> = -6mA	1.25		
		V <sub>CC</sub> = 2.3V; I <sub>OH</sub> = -6mA	2.0		
		V <sub>CC</sub> = 2.3V; I <sub>OH</sub> = -12mA	1.8		
		V <sub>CC</sub> = 2.3V; I <sub>OH</sub> = -18mA	1.7		
		V <sub>CC</sub> = 2.7V; I <sub>OH</sub> = -12mA	2.2		
		V <sub>CC</sub> = 3.0V; I <sub>OH</sub> = -18mA	2.4		
V <sub>CC</sub> = 3.0V; I <sub>OH</sub> = -24mA	2.2				
V <sub>OL</sub>	LOW Level Output Voltage	1.65V ≤ V <sub>CC</sub> ≤ 3.6V; I <sub>OL</sub> = 100μA		0.2	V
		V <sub>CC</sub> = 1.65V; I <sub>OL</sub> = 6mA		0.3	
		V <sub>CC</sub> = 2.3V; I <sub>OL</sub> = 12mA		0.4	
		V <sub>CC</sub> = 2.3V; I <sub>OL</sub> = 18mA		0.6	
		V <sub>CC</sub> = 2.7V; I <sub>OL</sub> = 12mA		0.4	
		V <sub>CC</sub> = 3.0V; I <sub>OL</sub> = 18mA		0.4	
		V <sub>CC</sub> = 3.0V; I <sub>OL</sub> = 24mA		0.55	
I <sub>I</sub>	Input Leakage Current	1.65V ≤ V <sub>CC</sub> ≤ 3.6V; 0V ≤ V <sub>I</sub> ≤ 3.6V		±5.0	μA
I <sub>OZ</sub>	3-State Output Current	1.65V ≤ V <sub>CC</sub> ≤ 3.6V; 0V ≤ V <sub>O</sub> ≤ 3.6V; V <sub>I</sub> = V <sub>IH</sub> or V <sub>IL</sub>		±10	μA
I <sub>OFF</sub>	Power-Off Leakage Current	V <sub>CC</sub> = 0V; V <sub>I</sub> or V <sub>O</sub> = 3.6V		10	μA
I <sub>CC</sub>	Quiescent Supply Current (Note 3.)	1.65V ≤ V <sub>CC</sub> ≤ 3.6V; V <sub>I</sub> = GND or V <sub>CC</sub>		20	μA
		1.65V ≤ V <sub>CC</sub> ≤ 3.6V; 3.6V ≤ V <sub>I</sub> , V <sub>O</sub> ≤ 3.6V		±20	μA
ΔI <sub>CC</sub>	Increase in I <sub>CC</sub> per Input	2.7V < V <sub>CC</sub> ≤ 3.6V; V <sub>IH</sub> = V <sub>CC</sub> - 0.6V		750	μA

2. These values of V<sub>I</sub> are used to test DC electrical characteristics only.

3. Outputs disabled or 3-state only.

## AC CHARACTERISTICS (Note 4.; t<sub>R</sub> = t<sub>F</sub> = 2.0ns; C<sub>L</sub> = 30pF; R<sub>L</sub> = 500Ω)

Symbol	Parameter	Waveform	Limits						Unit
			T <sub>A</sub> = -40°C to +85°C						
			V <sub>CC</sub> = 3.0V to 3.6V		V <sub>CC</sub> = 2.3V to 2.7V		V <sub>CC</sub> = 1.65 to 1.95V		
		Min	Max	Min	Max	Min	Max		
t <sub>PLH</sub>	Propagation Delay Input to Output	1	0.8	2.5	1.0	3.0	1.5	6.0	ns
t <sub>PHL</sub>			0.8	2.5	1.0	3.0	1.5	6.0	
t <sub>PZH</sub>	Output Enable Time to High and Low Level	2	0.8	3.5	1.0	4.1	1.5	8.2	ns
t <sub>PZL</sub>			0.8	3.5	1.0	4.1	1.5	8.2	
t <sub>PHZ</sub>	Output Disable Time From High and Low Level	2	0.8	3.5	1.0	3.8	1.5	7.8	ns
t <sub>PLZ</sub>			0.8	3.5	1.0	3.8	1.5	7.8	
t <sub>OSSL</sub>	Output-to-Output Skew (Note 5.)			0.5		0.5		0.75	ns
t <sub>OSLH</sub>				0.5		0.5		0.75	

4. For C<sub>L</sub> = 50pF, add approximately 300ps to the AC maximum specification.

5. Skew is defined as the absolute value of the difference between the actual propagation delay for any two separate outputs of the same device. The specification applies to any outputs switching in the same direction, either HIGH-to-LOW (t<sub>OSSL</sub>) or LOW-to-HIGH (t<sub>OSLH</sub>); parameter guaranteed by design.

# 74VCX16240

## DYNAMIC SWITCHING CHARACTERISTICS

Symbol	Characteristic	Condition	T <sub>A</sub> = +25°C	Unit
			Typ	
V <sub>OLP</sub>	Dynamic LOW Peak Voltage (Note 6.)	V <sub>CC</sub> = 1.8V, C <sub>L</sub> = 30pF, V <sub>IH</sub> = V <sub>CC</sub> , V <sub>IL</sub> = 0V	0.25	V
		V <sub>CC</sub> = 2.5V, C <sub>L</sub> = 30pF, V <sub>IH</sub> = V <sub>CC</sub> , V <sub>IL</sub> = 0V	0.6	
		V <sub>CC</sub> = 3.3V, C <sub>L</sub> = 30pF, V <sub>IH</sub> = V <sub>CC</sub> , V <sub>IL</sub> = 0V	0.8	
V <sub>OLV</sub>	Dynamic LOW Valley Voltage (Note 6.)	V <sub>CC</sub> = 1.8V, C <sub>L</sub> = 30pF, V <sub>IH</sub> = V <sub>CC</sub> , V <sub>IL</sub> = 0V	-0.25	V
		V <sub>CC</sub> = 2.5V, C <sub>L</sub> = 30pF, V <sub>IH</sub> = V <sub>CC</sub> , V <sub>IL</sub> = 0V	-0.6	
		V <sub>CC</sub> = 3.3V, C <sub>L</sub> = 30pF, V <sub>IH</sub> = V <sub>CC</sub> , V <sub>IL</sub> = 0V	-0.8	
V <sub>OHV</sub>	Dynamic HIGH Valley Voltage (Note 7.)	V <sub>CC</sub> = 1.8V, C <sub>L</sub> = 30pF, V <sub>IH</sub> = V <sub>CC</sub> , V <sub>IL</sub> = 0V	1.5	V
		V <sub>CC</sub> = 2.5V, C <sub>L</sub> = 30pF, V <sub>IH</sub> = V <sub>CC</sub> , V <sub>IL</sub> = 0V	1.9	
		V <sub>CC</sub> = 3.3V, C <sub>L</sub> = 30pF, V <sub>IH</sub> = V <sub>CC</sub> , V <sub>IL</sub> = 0V	2.2	

6. Number of outputs defined as “n”. Measured with “n-1” outputs switching from HIGH-to-LOW or LOW-to-HIGH. The remaining output is measured in the LOW state.

7. Number of outputs defined as “n”. Measured with “n-1” outputs switching from HIGH-to-LOW or LOW-to-HIGH. The remaining output is measured in the HIGH state.

## CAPACITIVE CHARACTERISTICS

Symbol	Parameter	Condition	Typical	Unit
C <sub>IN</sub>	Input Capacitance	Note 8.	6	pF
C <sub>OUT</sub>	Output Capacitance	Note 8.	7	pF
C <sub>PD</sub>	Power Dissipation Capacitance	Note 8., 10MHz	20	pF

8. V<sub>CC</sub> = 1.8, 2.5 or 3.3V; V<sub>I</sub> = 0V or V<sub>CC</sub>.

# 74VCX16240

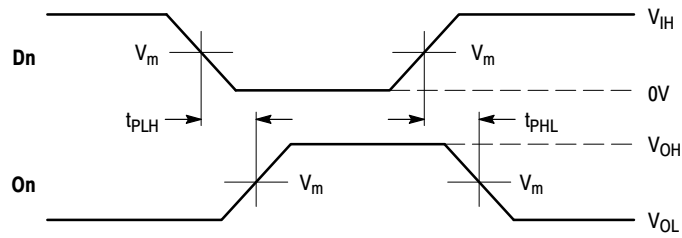

**WAVEFORM 1 - PROPAGATION DELAYS**  
 $t_R = t_F = 2.0\text{ns}$ , 10% to 90%;  $f = 1\text{MHz}$ ;  $t_W = 500\text{ns}$

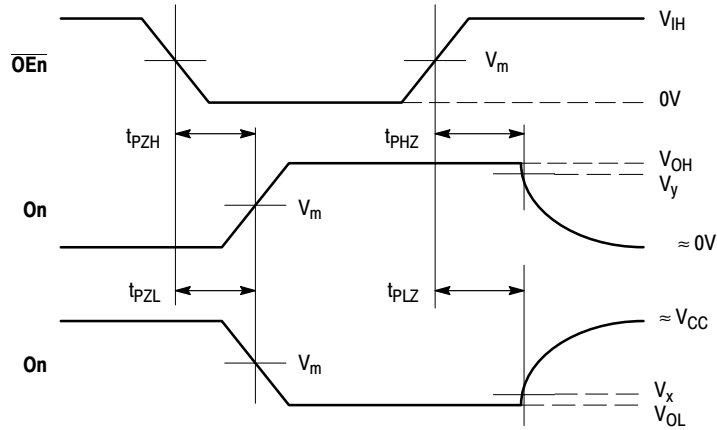

**WAVEFORM 2 - OUTPUT ENABLE AND DISABLE TIMES**  
 $t_R = t_F = 2.0\text{ns}$ , 10% to 90%;  $f = 1\text{MHz}$ ;  $t_W = 500\text{ns}$

**Figure 4. AC Waveforms**

Symbol	V <sub>CC</sub>		
	3.3V ±0.3V	2.5V ±0.2V	1.8V ±0.15V
V <sub>IH</sub>	2.7V	V <sub>CC</sub>	V <sub>CC</sub>
V <sub>m</sub>	1.5V	V <sub>CC</sub> /2	V <sub>CC</sub> /2
V <sub>x</sub>	V <sub>OL</sub> + 0.3V	V <sub>OL</sub> + 0.15V	V <sub>OL</sub> + 0.15V
V <sub>y</sub>	V <sub>OH</sub> - 0.3V	V <sub>OH</sub> - 0.15V	V <sub>OH</sub> - 0.15V

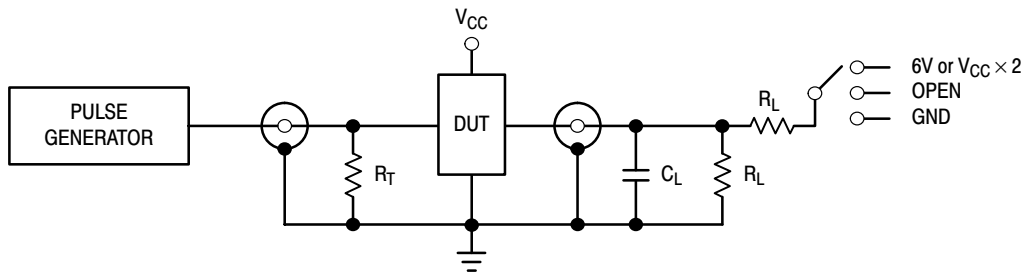

TEST	SWITCH
t <sub>PLH</sub> , t <sub>PHL</sub>	Open
t <sub>PZL</sub> , t <sub>PLZ</sub>	6V at V <sub>CC</sub> = 3.3 ±0.3V; V <sub>CC</sub> × 2 at V <sub>CC</sub> = 2.5 ±0.2V; 1.8 ±0.15V
t <sub>PZH</sub> , t <sub>PHZ</sub>	GND

C<sub>L</sub> = 30pF or equivalent (Includes jig and probe capacitance)  
R<sub>L</sub> = 500Ω or equivalent  
R<sub>T</sub> = Z<sub>OUT</sub> of pulse generator (typically 50Ω)

**Figure 5. Test Circuit**

# 74VCX16240

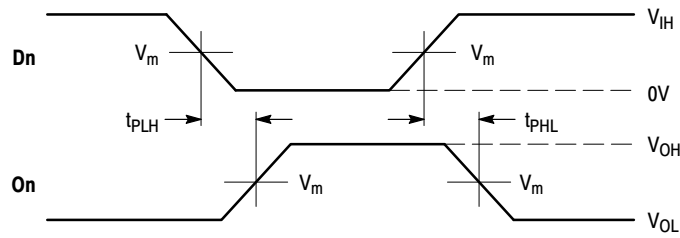

**WAVEFORM 3 - PROPAGATION DELAYS**  
 $t_R = t_F = 2.0\text{ns}$ , 10% to 90%;  $f = 1\text{MHz}$ ;  $t_W = 500\text{ns}$

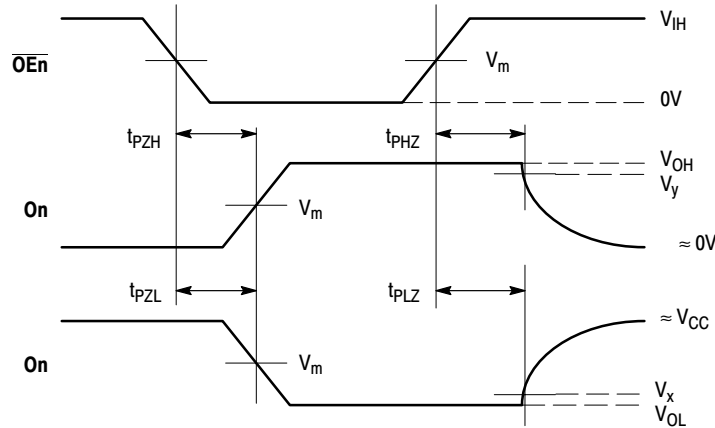

**WAVEFORM 4 - OUTPUT ENABLE AND DISABLE TIMES**  
 $t_R = t_F = 2.0\text{ns}$ , 10% to 90%;  $f = 1\text{MHz}$ ;  $t_W = 500\text{ns}$

**Figure 6. AC Waveforms**

Symbol	$V_{CC}$	
	$3.3\text{V} \pm 0.3\text{V}$	$2.7\text{V}$
$V_{IH}$	$2.7\text{V}$	$2.7\text{V}$
$V_m$	$1.5\text{V}$	$1.5\text{V}$
$V_x$	$V_{OL} + 0.3\text{V}$	$V_{OL} + 0.3\text{V}$
$V_y$	$V_{OH} - 0.3\text{V}$	$V_{OH} - 0.3\text{V}$

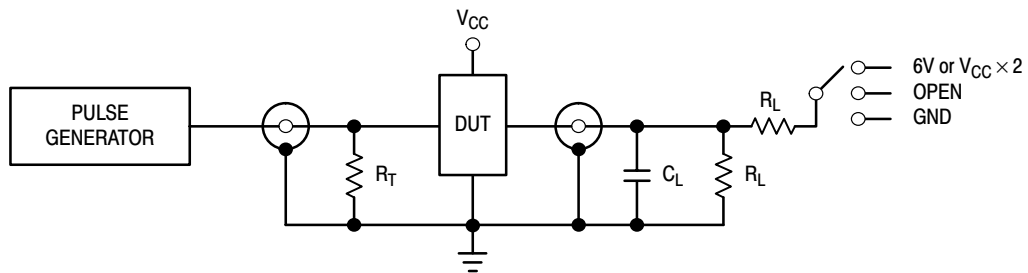

TEST	SWITCH
$t_{PLH}$ , $t_{PHL}$	Open
$t_{PZL}$ , $t_{PLZ}$	$6\text{V}$ at $V_{CC} = 3.3 \pm 0.3\text{V}$ ; $V_{CC} \times 2$ at $V_{CC} = 2.5 \pm 0.2\text{V}$ ; $1.8 \pm 0.15\text{V}$
$t_{PZH}$ , $t_{PHZ}$	GND

$C_L = 50\text{pF}$  or equivalent (Includes jig and probe capacitance)  
 $R_L = 500\Omega$  or equivalent  
 $R_T = Z_{OUT}$  of pulse generator (typically  $50\Omega$ )

**Figure 7. Test Circuit**

# 74VCX16240

## AC CHARACTERISTICS ( $t_R = t_F = 2.0\text{ns}$ ; $C_L = 50\text{pF}$ ; $R_L = 500\Omega$ )

Symbol	Parameter	Waveform	Limits				Unit
			$T_A = -40^\circ\text{C to } +85^\circ\text{C}$				
			$V_{CC} = 3.0\text{V to } 3.6\text{V}$		$V_{CC} = 2.7\text{V}$		
			Min	Max	Min	Max	
$t_{PLH}$ $t_{PHL}$	Propagation Delay Input to Output	3	1.0 1.0	3.9 3.9		5.3 5.3	ns
$t_{PZH}$ $t_{PZL}$	Output Enable Time to High and Low Level	4	1.0 1.0	5.0 5.0		6.1 6.1	ns
$t_{PHZ}$ $t_{PLZ}$	Output Disable Time From High and Low Level	4	1.0 1.0	4.4 4.4		4.8 4.8	ns
$t_{OSHL}$ $t_{OSLH}$	Output-to-Output Skew (Note 9.)			0.5 0.5		0.5 0.5	ns

9. Skew is defined as the absolute value of the difference between the actual propagation delay for any two separate outputs of the same device. The specification applies to any outputs switching in the same direction, either HIGH-to-LOW ( $t_{OSHL}$ ) or LOW-to-HIGH ( $t_{OSLH}$ ); parameter guaranteed by design.

# 74VCX16240

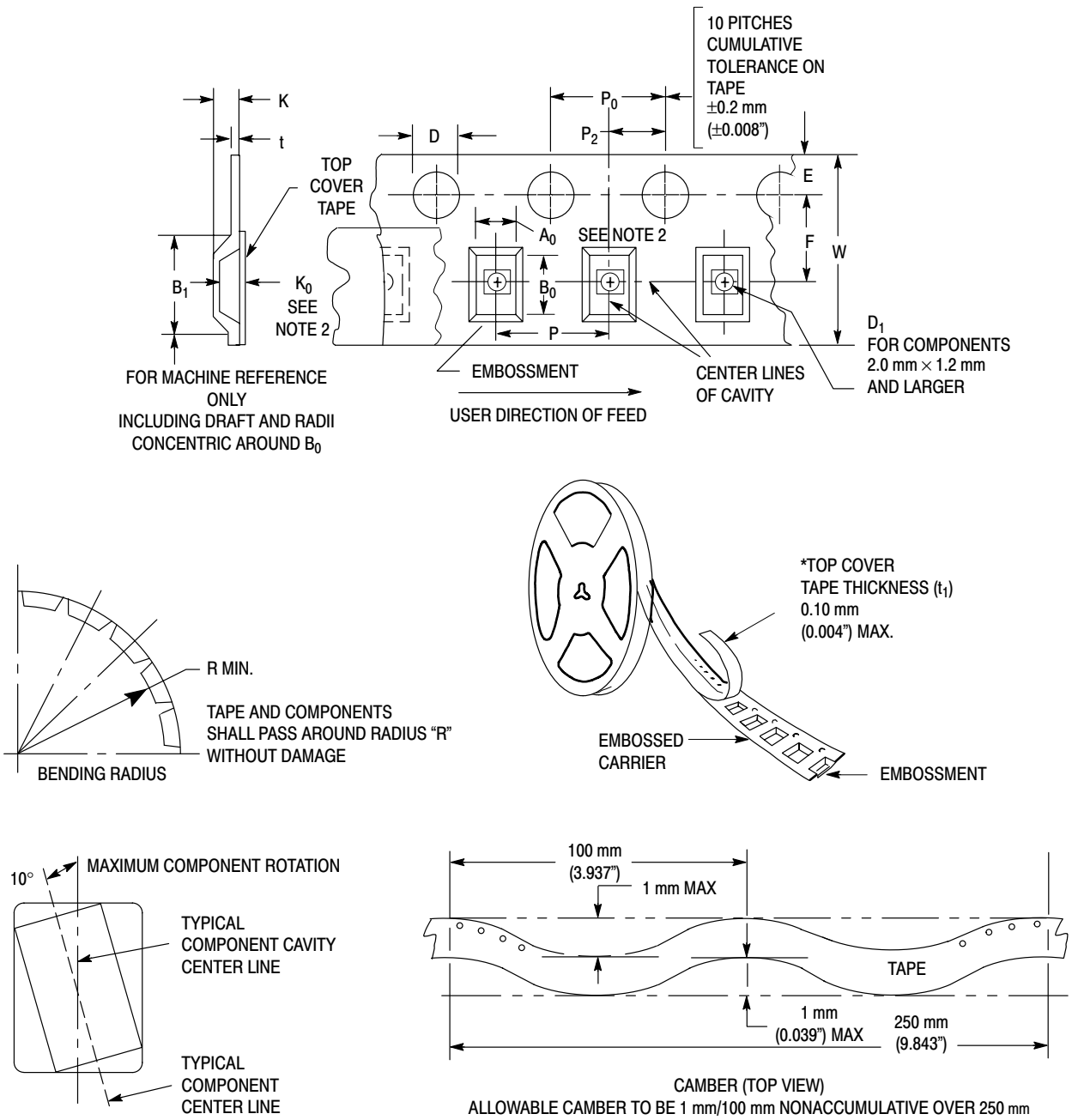

**Figure 8. Carrier Tape Specifications**

**EMBOSSED CARRIER DIMENSIONS** (See Notes 1 and 2)

Tape Size	B <sub>1</sub> Max	D	D <sub>1</sub>	E	F	K	P	P <sub>0</sub>	P <sub>2</sub>	R	T	W
24mm	20.1mm (0.791")	1.5 + 0.1mm -0.0 (0.059 +0.004" -0.0)	1.5mm Min (0.060")	1.75 ±0.1 mm (0.069 ±0.004")	11.5 ±0.10 mm (0.453 ±0.004")	11.9 mm Max (0.468")	16.0 ±0.1 mm (0.63 ±0.004")	4.0 ±0.1 mm (0.157 ±0.004")	2.0 ±0.1 mm (0.079 ±0.004")	30 mm (1.18")	0.6 mm (0.024")	24.3 mm (0.957")

1. Metric Dimensions Govern—English are in parentheses for reference only.
2. A<sub>0</sub>, B<sub>0</sub>, and K<sub>0</sub> are determined by component size. The clearance between the components and the cavity must be within 0.05 mm min to 0.50 mm max. The component cannot rotate more than 10° within the determined cavity.

# 74VCX16240

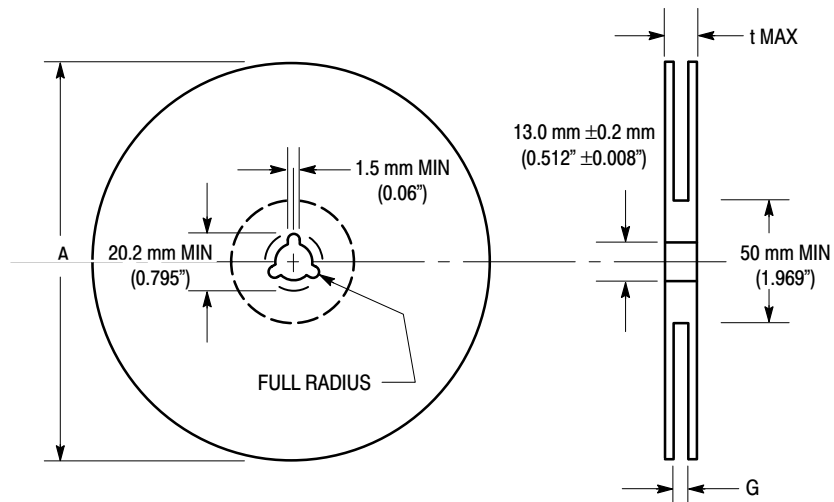

Figure 9. Reel Dimensions

## REEL DIMENSIONS

Tape Size	A Max	G	t Max
24 mm	360 mm (14.173")	24.4 mm + 2.0 mm, -0.0 (0.961" + 0.078", -0.00)	30.4 mm (1.197")

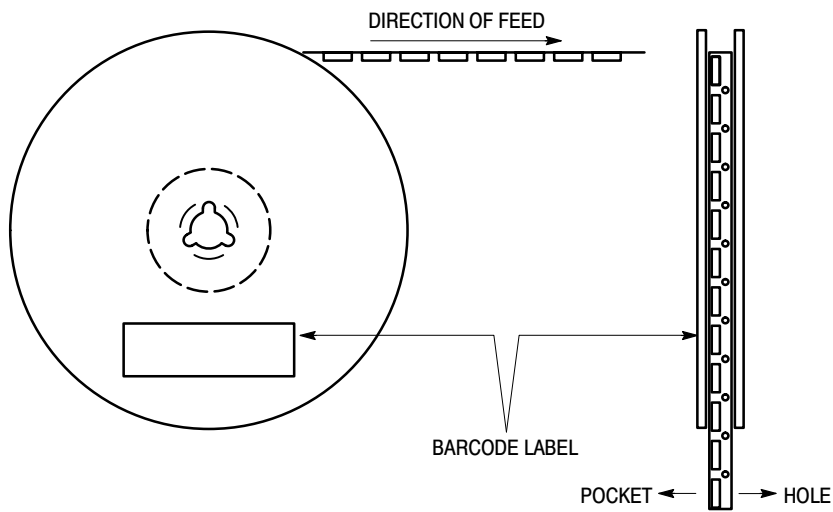

Figure 10. Reel Winding Direction

# 74VCX16240

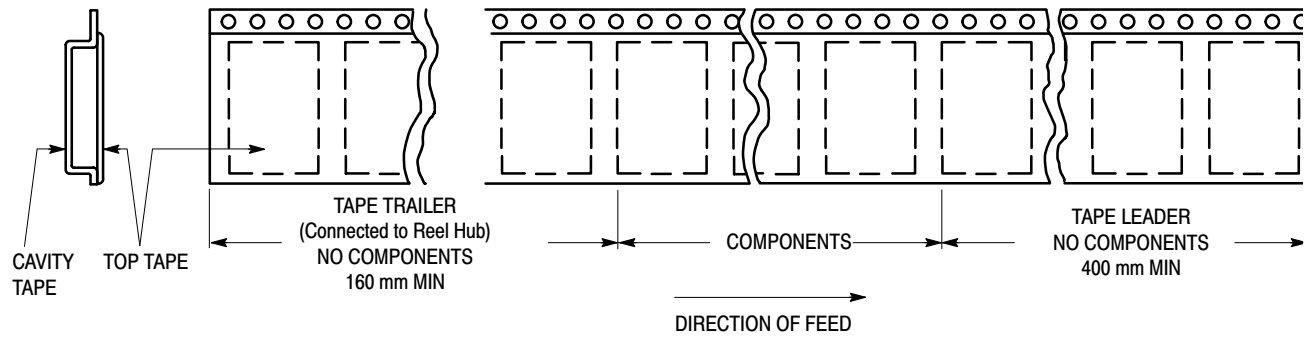

Figure 11. Tape Ends for Finished Goods

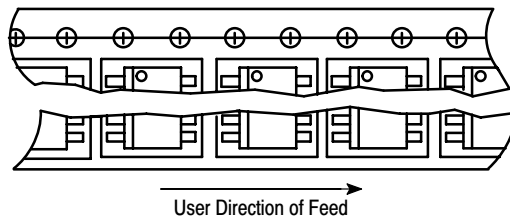

Figure 12. Reel Configuration

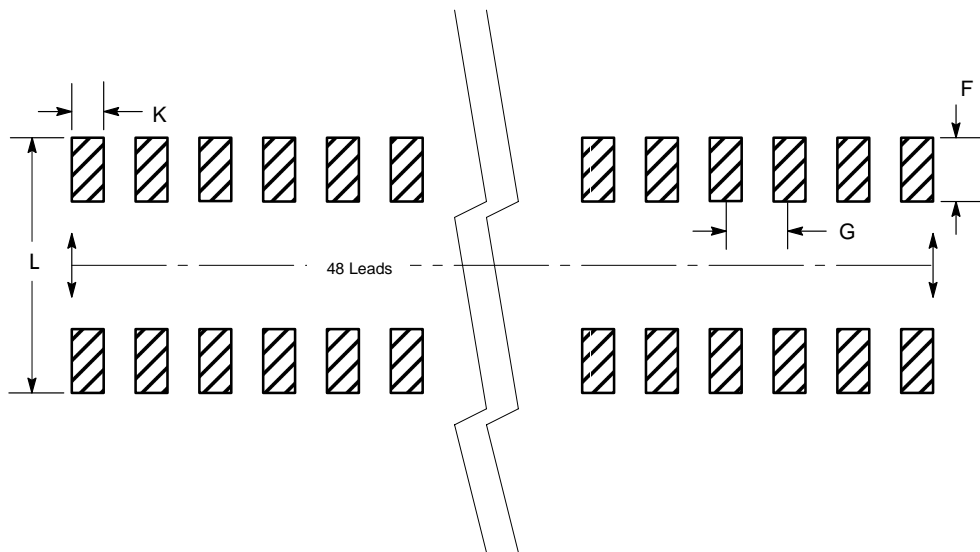
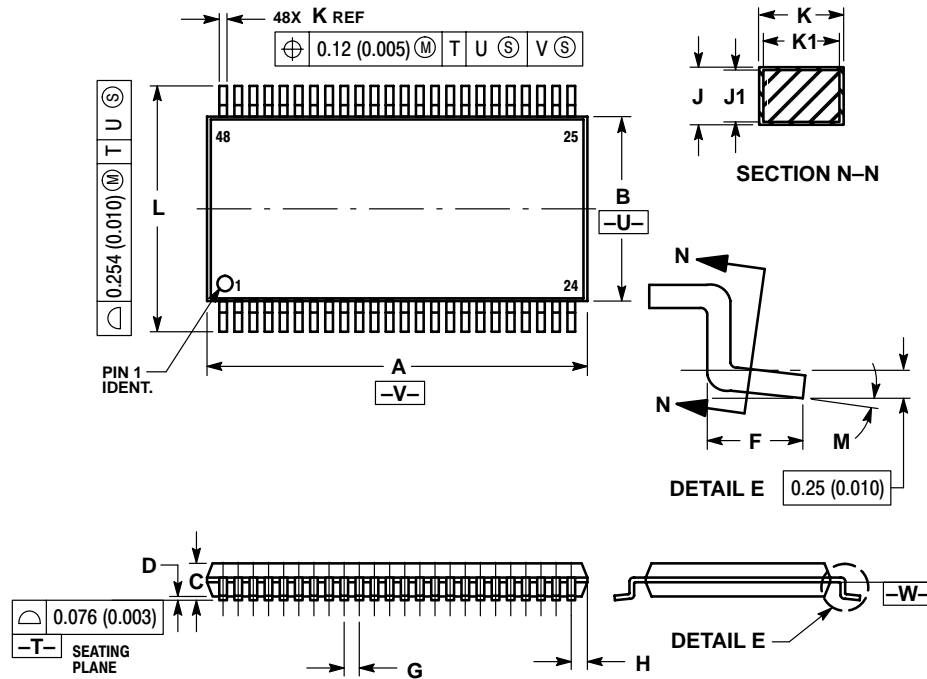

Figure 13. Package Footprint

# 74VCX16240

## PACKAGE DIMENSIONS

TSSOP  
DT SUFFIX  
CASE 1201-01  
ISSUE A



### NOTES:

1. DIMENSIONING AND TOLERANCING PER ANSI Y14.5M, 1982.
2. CONTROLLING DIMENSION: MILLIMETER.
3. DIMENSIONS A AND B DO NOT INCLUDE MOLD FLASH, PROTRUSIONS OR GATE BURRS. MOLD FLASH OR GATE BURRS SHALL NOT EXCEED 0.15 (0.006) PER SIDE.
4. DIMENSION K DOES NOT INCLUDE DAMBAR PROTRUSION. ALLOWABLE DAMBAR PROTRUSION SHALL BE 0.08 (0.003) TOTAL IN EXCESS OF THE K DIMENSION AT MAXIMUM MATERIAL CONDITION.
5. TERMINAL NUMBERS ARE SHOWN FOR REFERENCE ONLY.
6. DIMENSIONS A AND B ARE TO BE DETERMINED AT DATUM PLANE -W-.

DIM	MILLIMETERS		INCHES	
	MIN	MAX	MIN	MAX
A	12.40	12.60	0.488	0.496
B	6.00	6.20	0.236	0.244
C	---	1.10	---	0.043
D	0.05	0.15	0.002	0.006
F	0.50	0.75	0.020	0.030
G	0.50 BSC		0.0197 BSC	
H	0.37	---	0.015	---
J	0.09	0.20	0.004	0.008
J1	0.09	0.16	0.004	0.006
K	0.17	0.27	0.007	0.011
K1	0.17	0.23	0.007	0.009
L	7.95	8.25	0.313	0.325
M	0 °	8 °	0 °	8 °

**ON Semiconductor** and  are trademarks of Semiconductor Components Industries, LLC (SCILLC). SCILLC reserves the right to make changes without further notice to any products herein. SCILLC makes no warranty, representation or guarantee regarding the suitability of its products for any particular purpose, nor does SCILLC assume any liability arising out of the application or use of any product or circuit, and specifically disclaims any and all liability, including without limitation special, consequential or incidental damages. "Typical" parameters which may be provided in SCILLC data sheets and/or specifications can and do vary in different applications and actual performance may vary over time. All operating parameters, including "Typicals" must be validated for each customer application by customer's technical experts. SCILLC does not convey any license under its patent rights nor the rights of others. SCILLC products are not designed, intended, or authorized for use as components in systems intended for surgical implant into the body, or other applications intended to support or sustain life, or for any other application in which the failure of the SCILLC product could create a situation where personal injury or death may occur. Should Buyer purchase or use SCILLC products for any such unintended or unauthorized application, Buyer shall indemnify and hold SCILLC and its officers, employees, subsidiaries, affiliates, and distributors harmless against all claims, costs, damages, and expenses, and reasonable attorney fees arising out of, directly or indirectly, any claim of personal injury or death associated with such unintended or unauthorized use, even if such claim alleges that SCILLC was negligent regarding the design or manufacture of the part. SCILLC is an Equal Opportunity/Affirmative Action Employer.

## PUBLICATION ORDERING INFORMATION

### NORTH AMERICA Literature Fulfillment:

Literature Distribution Center for ON Semiconductor  
P.O. Box 5163, Denver, Colorado 80217 USA  
**Phone:** 303-675-2175 or 800-344-3860 Toll Free USA/Canada  
**Fax:** 303-675-2176 or 800-344-3867 Toll Free USA/Canada  
**Email:** ONlit@hibbertco.com  
Fax Response Line: 303-675-2167 or 800-344-3810 Toll Free USA/Canada

### N. American Technical Support: 800-282-9855 Toll Free USA/Canada

### EUROPE: LDC for ON Semiconductor – European Support

**German Phone:** (+1) 303-308-7140 (Mon-Fri 2:30pm to 7:00pm CET)  
**Email:** ONlit-german@hibbertco.com  
**French Phone:** (+1) 303-308-7141 (Mon-Fri 2:00pm to 7:00pm CET)  
**Email:** ONlit-french@hibbertco.com  
**English Phone:** (+1) 303-308-7142 (Mon-Fri 12:00pm to 5:00pm GMT)  
**Email:** ONlit@hibbertco.com

### EUROPEAN TOLL-FREE ACCESS\*: 00-800-4422-3781

\*Available from Germany, France, Italy, UK, Ireland

### CENTRAL/SOUTH AMERICA:

**Spanish Phone:** 303-308-7143 (Mon-Fri 8:00am to 5:00pm MST)  
**Email:** ONlit-spanish@hibbertco.com  
**Toll-Free from Mexico:** Dial 01-800-288-2872 for Access –  
then Dial 866-297-9322

### ASIA/PACIFIC: LDC for ON Semiconductor – Asia Support

**Phone:** 303-675-2121 (Tue-Fri 9:00am to 1:00pm, Hong Kong Time)  
**Toll Free from Hong Kong & Singapore:**  
**001-800-4422-3781**  
**Email:** ONlit-asia@hibbertco.com

### JAPAN: ON Semiconductor, Japan Customer Focus Center

4-32-1 Nishi-Gotanda, Shinagawa-ku, Tokyo, Japan 141-0031  
**Phone:** 81-3-5740-2700  
**Email:** r14525@onsemi.com

### ON Semiconductor Website: <http://onsemi.com>

For additional information, please contact your local Sales Representative.