

NC7S08

Tiny 2-Input AND Gate

General Description

The NC7S08 is a single 2-Input high performance CMOS AND Gate in National's TinyPak™ package. Advanced Silicon Gate CMOS fabrication assures high speed and low power circuit operation over a broad V_{CC} range. ESD protection diodes inherently guard both inputs and output with respect to the V_{CC} and GND rails. Three stages of gain between inputs and outputs assures high noise immunity and reduced sensitivity to input edge rate.

Features

- Space saving TinyPak package, 5-lead surface mount SOT23 package
- High Speed; T_{PD} 3.5 ns typ
- Low Quiescent Power; $I_{CC} < 1 \mu A$
- Balanced Output Drive; 2 mA I_{OL} , -2 mA I_{OH}
- Broad V_{CC} Operating Range; 2V–6V
- Balanced Propagation Delays
- Specified for 3V operation

Product Code	Package	Package Drawing	Package Top Mark	Supplied As
NC7S08M5	5-Pin SOT-23-5	MA05B	7S08	250 Units on Tape and Reel
NC7S08M5X	5-Pin SOT-23-5	MA05B	7S08	3k Units on Tape and Reel

Logic Symbol

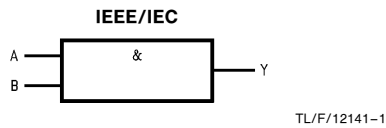

Connection Diagram

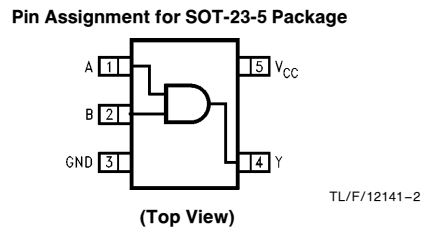

Function Table

$$Y = AB$$

Inputs		Output
A	B	Y
L	L	L
L	H	L
H	L	L
H	H	H

H = HIGH Logic Level
L = LOW Logic Level

Pin Descriptions

Pin Names	Description
A, B	Inputs
Y	Output

Absolute Maximum Ratings (Note 1)

Supply Voltage (V_{CC})	-0.5V to +7.0V
DC Input Diode Current (I_{IK})	
@ $V_I \leq -0.5V$	-20 mA
@ $V_I \geq V_{CC} + 0.5V$	+20 mA
DC Input Voltage (V_I)	-0.5V to $V_{CC} + 0.5V$
DC Output Diode Current (I_{OK})	
@ $V_O < -0.5V$	-20 mA
@ $V_O > V_{CC} + 0.5V$	+20 mA
DC Output Voltage (V_O)	-0.5V to $V_{CC} + 0.5V$
DC Output Source or Sink Current (I_O)	± 12.5 mA
DC V_{CC} or Ground Current per Output Pin (I_{CC} or I_{GND})	± 25 mA
Storage Temperature (T_{STG})	-65°C to +150°C
Junction Temperature (T_J)	150°C
Lead Temp. (T_L); (Soldering, 10 sec.)	260°C
Power Dissipation (P_D)	200 mW

Note 1: Absolute maximum ratings are those values beyond which damage to the device may occur. The databook specifications should be met, without exception, to ensure that the system design is reliable over its power supply, temperature, and output/input loading variables. National does not recommend operation of circuits outside databook specifications.

ESD Tolerance (Human Body Model) MIL-STD-883D Method 3015.7	> 1000V
DC Latchup Tolerance Source Current (JEDEC Method 17)	± 500 mA

Recommended Operating Conditions

Supply Voltage (V_{CC})	2.0V-6.0V
Input Voltage (V_I)	0V- V_{CC}
Output Voltage (V_O)	0V- V_{CC}
Operating Temperature (T_A)	-40°C to +85°C
Input Rise and Fall Time	
V_{CC} @ 2.0V	0-1000 ns
V_{CC} @ 3.0V	0-750 ns
V_{CC} @ 4.5V	0-500 ns
V_{CC} @ 6.0V	0-400 ns
Thermal Resistance (θ_{JA})	275°C/W

DC Electrical Characteristics

Symbol	Parameter	V_{CC} (V)	NC7S08			NC7S08		Units	Conditions
			$T_A = +25^\circ\text{C}$			$T_A = -40^\circ\text{C to } +85^\circ\text{C}$			
			Min	Typ	Max	Min	Max		
V_{IH}	High Level Input Voltage	2.0	1.50		1.50		V		
		3.0	2.10		2.10				
		4.5	3.15		3.15				
		6.0	4.20		4.20				
V_{IL}	Low Level Input Voltage	2.0		0.50		0.50	V		
		3.0		0.90		0.90			
		4.5		1.35		1.35			
		6.0		1.80		1.80			
V_{OH}	High Level Output Voltage	2.0	1.90	2.0	1.90		V	$I_{OH} = -20 \mu\text{A}$ $V_{IN} = V_{IL}$	
		3.0	2.90	3.0	2.90				
		4.5	4.40	4.5	4.40				
		6.0	5.90	6.0	5.90				
			3.0	2.68	2.85	2.63		V	$V_{IN} = V_{IL}$ $I_{OH} = -1.3 \text{ mA}$ $I_{OH} = -2 \text{ mA}$ $I_{OH} = -2.6 \text{ mA}$
			4.5	4.18	4.35	4.13			
			6.0	5.68	5.85	5.63			
V_{OL}	Low Level Output Voltage	2.0		0.0	0.10	0.10	V	$I_{OL} = 20 \mu\text{A}$ $V_{IN} = V_{IH} \text{ or } V_{IL}$	
		3.0		0.0	0.10	0.10			
		4.5		0.0	0.10	0.10			
		6.0		0.0	0.10	0.10			
			3.0		0.1	0.26	0.33	V	$V_{IN} = V_{IH} \text{ or } V_{IL}$ $I_{OH} = 1.3 \text{ mA}$ $I_{OL} = 2 \text{ mA}$ $I_{OL} = 2.6 \text{ mA}$
			4.5		0.1	0.26	0.33		
			6.0		0.1	0.26	0.33		
I_{IN}	Input Leakage Current	6.0		± 0.1		± 1.0	μA	$V_I = V_{CC}, \text{ GND}$	
I_{CC}	Quiescent Supply Current	6.0		1.0		10.0	μA	$V_I = V_{CC}, \text{ GND}$	

AC Electrical Characteristics

Symbol	Parameter	V _{CC} (V)	NC7S08			NC7S08		Units	Conditions	Fig. No.
			T _A = +25°C			T _A = -40°C to +85°C				
			Min	Typ	Max	Min	Max			
t _{PLH} , t _{PHL}	Propagation Delay	5.0	3.5	15			ns	C _L = 15 pF	1, 2	
		2.0	20	100		125		C _L = 50 pF		
		3.0	11	27		35	ns			
		4.5	8	20		25				
		6.0	7	17		21				
t _{TLH} , t _{THL}	Output Transition Time	5.0	3.0	10			ns	C _L = 15 pF	1, 2	
		2.0	25	125		155		C _L = 50 pF		
		3.0	16	35		45	ns			
		4.5	11	25		31				
		6.0	9	21		26				
*C _{IN}	*Input Capacitance	Open	2	10		10	pF			
C _{PD}	Power Dissipation Capacitance	5.0	6				pF	(Note 1)	3	

*Parameter guaranteed by design. Not tested.

Note 1: C_{PD} is defined as the value of the internal equivalent capacitance which is derived from dynamic operating current consumption (I_{CCD}) at no output loading and operating at 50% duty cycle. (See Figure 3.)

C_{PD} is related to I_{CCD} dynamic operating current by the expression: I_{CCD} = (C_{PD})(V_{CC})(f_{IN}) + (I_{CC}static).

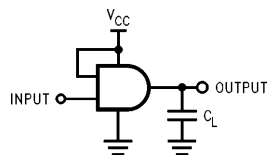

TL/F/12141-3

FIGURE 1. AC Test Circuit

Note 2: C_L includes load and stray capacitance

Note 3: Input PRR = 1.0 MHz; t_w = 500 ns

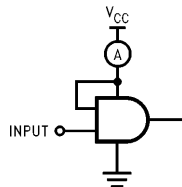

TL/F/12141-5

FIGURE 3. I_{CCD} Test Circuit

Note 4: Input = AC Waveform;

PRR = variable; Duty Cycle = 50%

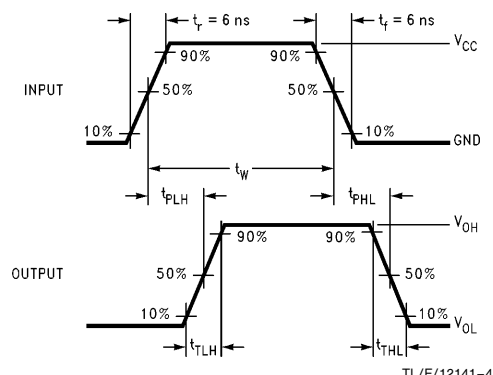

TL/F/12141-4

FIGURE 2. AC Waveforms

Ordering Information

The device number is used to form part of a simplified purchasing code where the package type and temperature range are defined as follows:

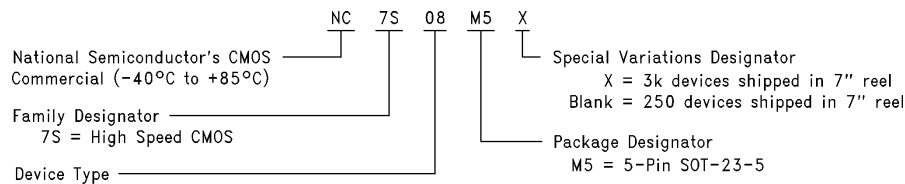

TL/F/12141-6

SOT-23-5 Tape and Reel Specification

Tape Format

Tape Section	# Cavities	Cavity Status	Cover Tape Status
Leader (Start End)	0 (min)	Empty	Sealed
	75 (min)	Empty	Sealed
Carrier	3000	Filled	Sealed
	250	Filled	Sealed
Trailer (Hub End)	125 (min)	Empty	Sealed
	0 (min)	Empty	Sealed

Tape Dimensions inches (millimeters)

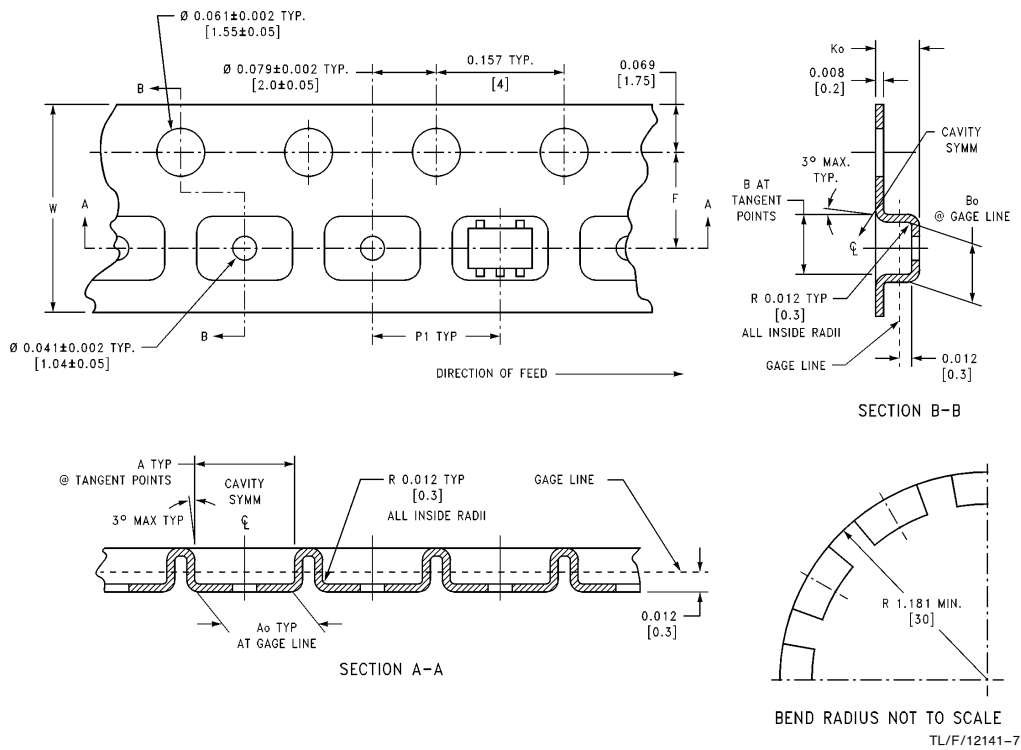

8 mm	0.130 (3.3)	0.124 (3.15)	0.130 (3.3)	0.126 (3.2)	0.138 ± 0.002 (3.5 ± 0.05)	0.055 ± 0.004 (1.4 ± 0.11)	0.157 (4)	0.315 ± 0.012 (8 ± 0.3)
Tape Size	DIM A	DIM A _o	DIM B	DIM B _o	DIM F	DIM K _o	DIM P1	DIM W

Reel Dimensions inches (millimeters)

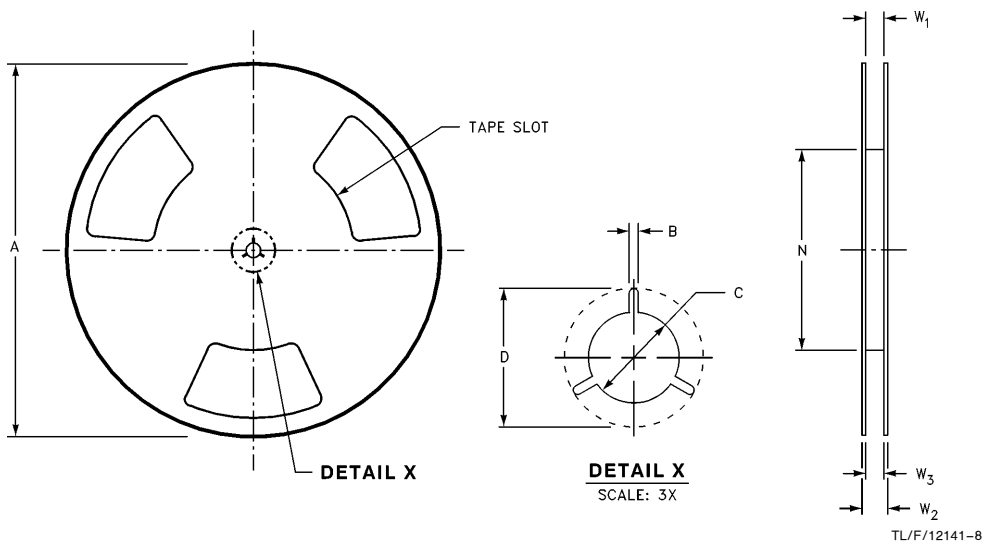

8 mm	7.00 (177.8)	0.059 (1.50)	0.512 (13.00)	0.795 (20.20)	2.165 (55.00)	0.331 + 0.059 / - 0.000 (8.40 1.50 / - 0.00)	0.567 (14.40)	W1 + 0.078 / - 0.039 (W1 2.00 / - 1.00)
Tape Size	A	B	C	D	N	W1	W2	W3

TL/F/12141-8

Physical Dimensions inches (millimeters) unless otherwise noted (Continued)

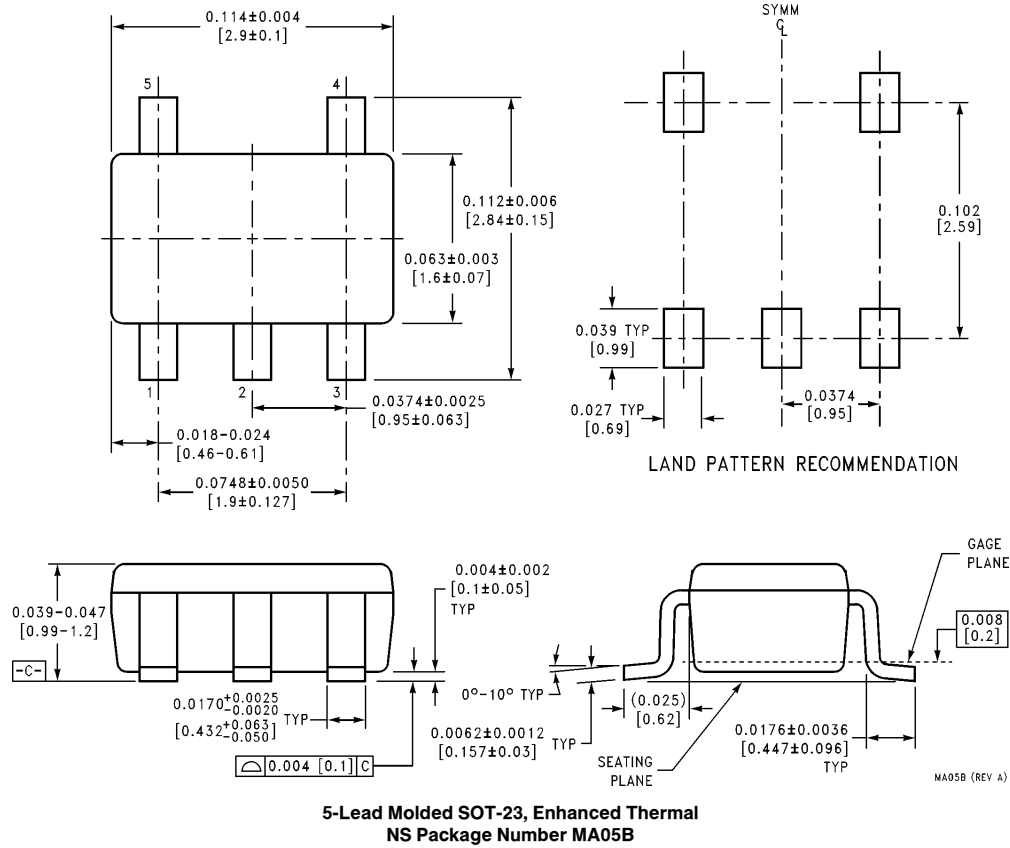

LIFE SUPPORT POLICY

NATIONAL'S PRODUCTS ARE NOT AUTHORIZED FOR USE AS CRITICAL COMPONENTS IN LIFE SUPPORT DEVICES OR SYSTEMS WITHOUT THE EXPRESS WRITTEN APPROVAL OF THE PRESIDENT OF NATIONAL SEMICONDUCTOR CORPORATION. As used herein:

1. Life support devices or systems are devices or systems which, (a) are intended for surgical implant into the body, or (b) support or sustain life, and whose failure to perform, when properly used in accordance with instructions for use provided in the labeling, can be reasonably expected to result in a significant injury to the user.
2. A critical component is any component of a life support device or system whose failure to perform can be reasonably expected to cause the failure of the life support device or system, or to affect its safety or effectiveness.

 <p>National Semiconductor Corporation Americas Tel: 1(800) 272-9959 Fax: 1(800) 737-7018 Email: support@nsc.com</p>	<p>National Semiconductor Europe Fax: +49 (0) 180-530 85 86 Email: europe.support@nsc.com</p>	<p>National Semiconductor Southeast Asia Fax: (852) 2376 3901 Email: sea.support@nsc.com</p>	<p>National Semiconductor Japan Ltd. Tel: 81-3-5620-7561 Fax: 81-3-5620-6179</p>
	<p>Deutsch Tel: +49 (0) 180-530 85 85 English Tel: +49 (0) 180-532 78 32 Français Tel: +49 (0) 180-532 93 58 Italiano Tel: +49 (0) 180-534 16 80</p>	<p>http://www.national.com</p>	

National does not assume any responsibility for use of any circuitry described, no circuit patent licenses are implied and National reserves the right at any time without notice to change said circuitry and specifications.