

NC7SZ02 Tiny UHS 2-Input NOR Gate

General Description

The NC7SZ02 is a single 2-Input NOR Gate from National's Ultra High Speed Series of TinyLogic in the space saving TinyPak™ package. The device is fabricated with advanced CMOS technology to achieve ultra high speed with high output drive while maintaining low static power dissipation over a very broad V_{CC} operating range. The device is specified to operate over the 1.8V to 5.5V V_{CC} range. The inputs and output are high impedance when V_{CC} is 0V. Inputs tolerate voltages up to 6V independent of V_{CC} operating voltage.

Features

- Space saving 5-lead surface mount SOT-23 package
- Ultra High Speed; T_{PD} 2.4 ns typ into 50 pF at 5V V_{CC}
- High Output Drive; ± 24 mA at 3V V_{CC}
- Broad V_{CC} Operating Range; 1.8V–5.5V
- Matches the performance of LCX when operated at 3.3V V_{CC}
- Power down high impedance inputs/output
- Overvoltage tolerant inputs facilitate 5V to 3V translation
- Quiet Series™ noise/EMI reduction circuitry implemented

Product Code	Package	Package Drawing	Package Top Mark	Supplied As
NC7SZ02M5	5-Pin SOT-23-5	MA05B	7Z02	250 Units on Tape and Reel
NC7SZ02M5X	5-Pin SOT-23-5	MA05B	7Z02	3k Units on Tape and Reel

Logic Symbol

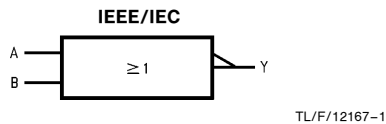

Connection Diagram

Pin Assignment for SOT-23-5 Package

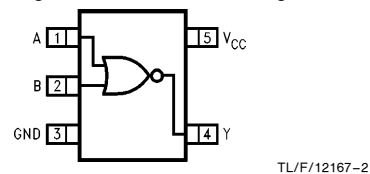

(Top View)

Function Table

$$Y = \overline{A + B}$$

Inputs		Output
A	B	Y
L	L	H
L	H	L
H	L	L
H	H	L

H = HIGH Logic Level
L = LOW Logic Level

Pin Descriptions

Pin Names	Description
A, B	Inputs
Y	Output

Absolute Maximum Ratings (Note 1)

Supply Voltage (V_{CC})	-0.5V to +6V
DC Input Voltage (V_{IN})	-0.5V to +6V
DC Output Voltage (V_{OUT})	-0.5V to +6V
DC Input Diode Current (I_{IK})	
@ $V_{IN} < -0.5V$	-50 mA
@ $V_{IN} > 6V$	+20 mA
DC Output Diode Current (I_{OK})	
@ $V_{OUT} < -0.5V$	-50 mA
@ $V_{OUT} > 6V, V_{CC} = GND$	+20 mA
DC Output Current (I_{OL}/I_{OH})	± 50 mA
DC V_{CC}/GND Current (I_{CC}/I_{GND})	± 50 mA
Storage Temperature (T_{STG})	-65°C to +150°C
Junction Temperature under Bias (T_J)	150°C
Junction Lead Temperature (T_L); (Soldering, 10 seconds)	260°C
Package Power Dissipation @ +70°C	200 mW
ESD Tolerance (Human Body Model) MIL-STD-883D Method 3015.7	1000V

DC Latchup Tolerance (JEDEC Method 17)	
Negative Source Current (NIT)	-500 mA
Positive Source Voltage (PVT)	+8V

Recommended Operating Conditions

Supply Voltage Operating (V_{CC})	1.8V to 5.5V
Supply Voltage Data Retention (V_{CC})	1.5V to 5.5V
Input Voltage (V_{IN})	0V to 5.5V
Output Voltage (V_{OUT})	0V to V_{CC}
Operating Temperature (T_{OPR})	-40°C to +85°C
Input Rise and Fall Time (t_r, t_f)	
$V_{CC} @ 1.8V, 2.5V \pm 0.2V$	0 ns to 20 ns/V
$V_{CC} @ 3.3V \pm 0.3V$	0 ns to 10 ns/V
$V_{CC} @ 5.0V \pm 0.5V$	0 ns to 5 ns/V
Thermal Resistance (θ_{JA} in Free Air)	300°C/W

Note 1: Absolute maximum ratings are DC values beyond which the device may be damaged or have its useful life impaired. The datasheet specifications should be met, without exception, to ensure that the system design is reliable over its power supply, temperature, and output/input loading variables. National does not recommend operation outside datasheet specifications.

DC Electrical Characteristics

Symbol	Parameter	V_{CC} (V)	NC7SZ02			NC7SZ02		Units	Conditions
			$T_A = +25^\circ\text{C}$			$T_A =$ -40°C to +85°C			
			Min	Typ	Max	Min	Max		
V_{IH}	High Level Input Voltage	1.8 2.3-5.5	0.75 V_{CC} 0.7 V_{CC}			0.75 V_{CC} 0.7 V_{CC}		V	
V_{IL}	Low Level Input Voltage	1.8 2.3-5.5	0.25 V_{CC} 0.3 V_{CC}			0.25 V_{CC} 0.3 V_{CC}		V	
V_{OH}	High Level Output Voltage	1.8 2.3 3.0 4.5	1.7 2.2 2.9 4.4	1.8 2.3 3.0 4.5	1.7 2.2 2.9 4.4			V	$V_{IN} = V_{IH}$ or V_{IL} $I_{OH} = -100 \mu\text{A}$
		2.3 3.0 3.0 4.5	1.9 2.4 2.3 3.8	2.15 2.80 2.68 4.20	1.9 2.4 2.3 3.8			V	$I_{OH} = -8 \text{ mA}$ $I_{OH} = -16 \text{ mA}$ $I_{OH} = -24 \text{ mA}$ $I_{OH} = -32 \text{ mA}$
V_{OL}	Low Level Output Voltage	1.8 2.3 3.0 4.5	0.0 0.0 0.0 0.0			0.1 0.1 0.1 0.1		V	$V_{IN} = V_{IH}$ or V_{IL} $I_{OL} = 100 \mu\text{A}$
		2.3 3.0 3.0 4.5	0.10 0.15 0.22 0.22	0.3 0.4 0.55 0.55	0.3 0.4 0.55 0.55				V
I_{IN}	Input Leakage Current	5.5	± 1			± 10		μA	$V_{IN} = 5.5V, GND$
I_{OFF}	Power Off Leakage Current	0.0	1			10		μA	V_{IN} or $V_{OUT} = 5.5V$
I_{CC}	Quiescent Supply Current	5.5	2.0			20		μA	$V_{IN} = 5.5V, GND$

AC Electrical Characteristics

Symbol	Parameter	V _{CC} (V)	NC7SZ02			NC7SZ02		Units	Conditions	Fig. No.
			T _A = +25°C			T _A = -40°C to +85°C				
			Min	Typ	Max	Min	Max			
t _{PLH} , t _{PHL}	Propagation Delay	1.8	2.0	4.4	9.5	2.0	10	ns	C _L = 15 pF, R _L = 1 MΩ	1, 2
		2.5 ± 0.2	0.8	2.9	6.5	0.8	7.0			
		3.3 ± 0.3	0.5	2.3	4.5	0.5	4.7			
		5.0 ± 0.5	0.5	1.9	3.9	0.5	4.1			
t _{PLH} , t _{PHL}	Propagation Delay	3.3 ± 0.3	1.5	2.9	5.0	1.5	5.2	ns	C _L = 50 pF, R _L = 500Ω	1, 2
		5.0 ± 0.5	0.8	2.4	4.3	0.8	4.5			
C _{IN}	Input Capacitance	0	4					pF		
C _{PD}	Power Dissipation Capacitance	3.3	23					pF	(Note 1)	3
		5.0	30							

Note 1: C_{PD} is defined as the value of the internal equivalent capacitance which is derived from dynamic operating current consumption (I_{CCD}) at no output loading and operating at 50% duty cycle. (See Figure 3.)

C_{PD} is related to I_{CCD} dynamic operating current by the expression: I_{CCD} = (C_{PD})(V_{CC})(f_{IN}) + (I_{CC}Static).

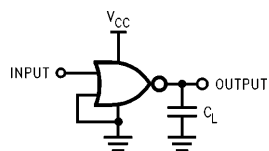

TL/F/12167-3

Note 2: C_L includes load and stray capacitance

Note 3: Input PRR = 1.0 MHz; T_W = 500 ns

FIGURE 1. AC Test Circuit

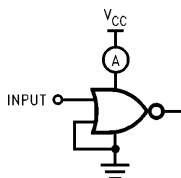

TL/F/12167-5

Note 4: Input = AC Waveform; t_r = t_f = 1.8 ns;

PRR = 10 MHz; Duty Cycle = 50%

FIGURE 3. I_{CCD} Test Circuit

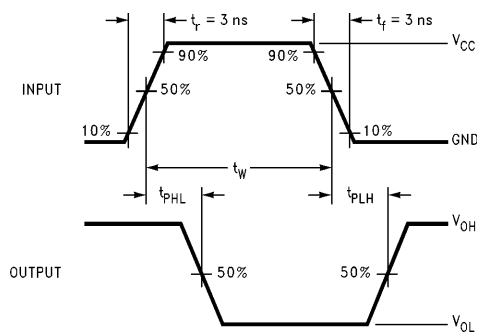

TL/F/12167-4

FIGURE 2. AC Waveforms

Ordering Information

The device number is used to form part of a simplified purchasing code where the package type and temperature range are defined as follows:

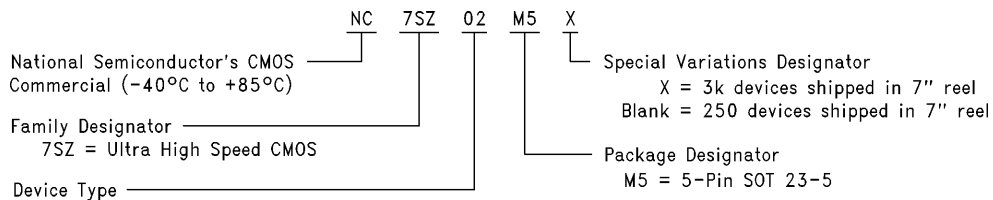

TL/F/12167-6

SOT-23-5 Tape and Reel Specification inches (millimeters)

Tape Format

Tape Section	# Cavities	Cavity Status	Cover Tape Status
Leader (Start End)	0 (min)	Empty	Unsealed
	75 (min)	Empty	Sealed
Carrier	3000	Filled	Sealed
	250	Filled	Sealed
Trailer (Hub End)	125 (min)	Empty	Sealed
	0 (min)	Empty	Unsealed

TAPE DIMENSIONS inches (millimeters)

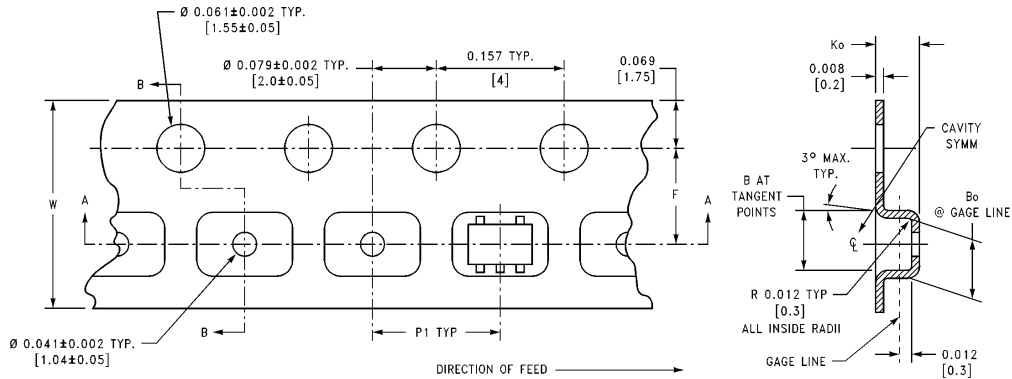

SECTION B-B

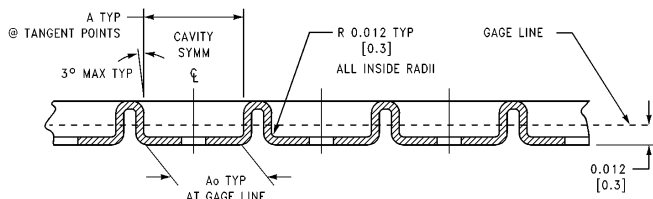

SECTION A-A

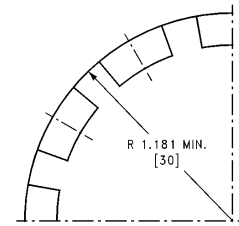

BEND RADIUS NOT TO SCALE
TL/F/12167-7

8mm	0.130 (3.3)	0.124 (3.15)	0.130 (3.3)	0.126 (3.2)	0.138 ± 0.002 (3.5 ± 0.05)	0.055 ± 0.004 (1.4 ± 0.11)	0.157 (4)	0.315 ± 0.012 (8 ± 0.3)
Tape Size	DIM A	DIM Ao	DIM B	DIM Bo	DIM F	DIM Ko	DIM P1	DIM W

SOT-23-5 Tape and Reel Specification inches (millimeters) (Continued)

REEL DIMENSIONS

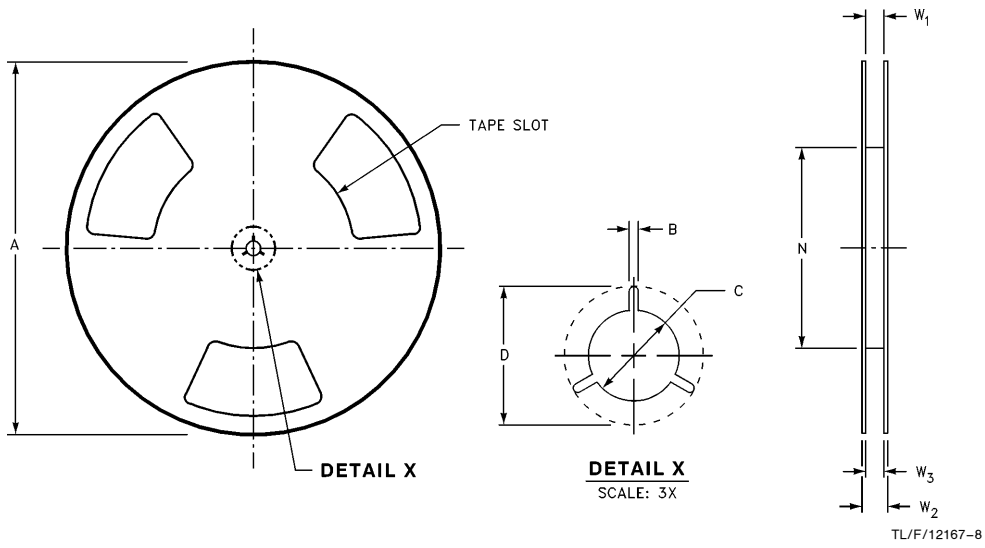

8mm	7.00 (177.8)	0.059 (1.50)	0.512 (13.00)	0.795 (20.20)	2.165 (55.00)	0.331 + 0.059/-0.000 (8.40 1.50/-0.00)	0.567 (14.40)	W1 + 0.078/-0.039 (W1 2.00/-1.00)
Tape Size	A	B	C	D	N	W1	W2	W3

Physical Dimensions inches (millimeters) unless otherwise noted

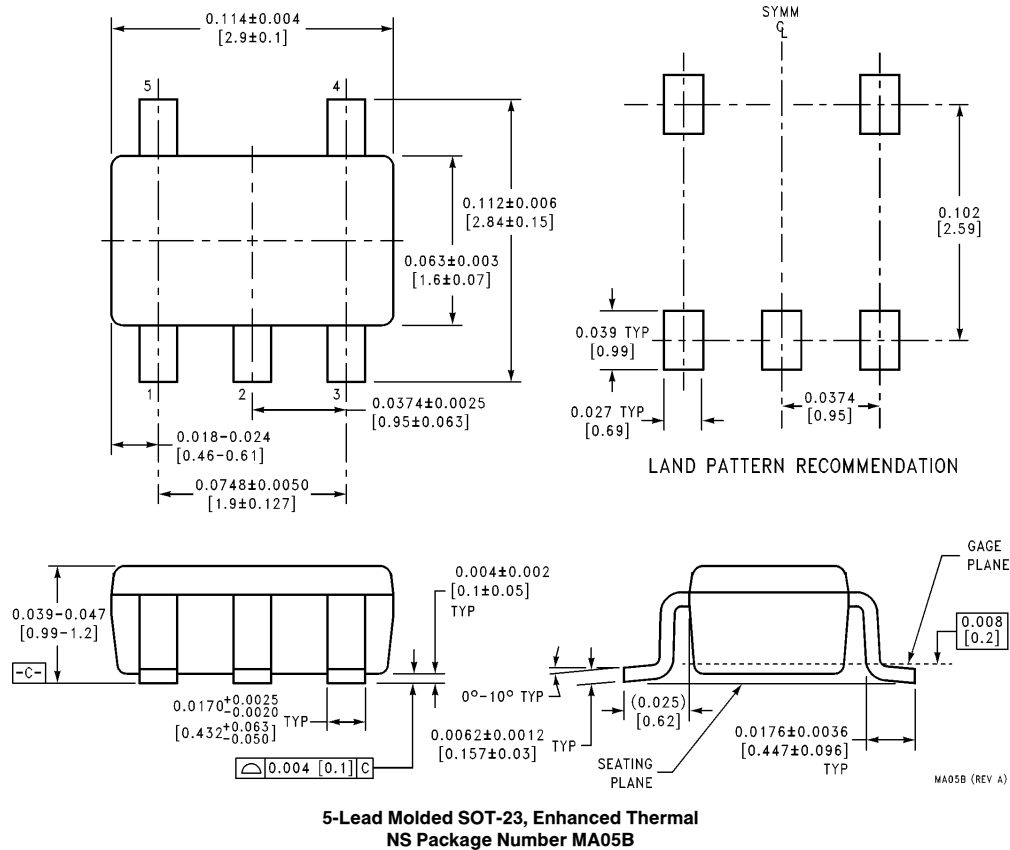

LIFE SUPPORT POLICY

NATIONAL'S PRODUCTS ARE NOT AUTHORIZED FOR USE AS CRITICAL COMPONENTS IN LIFE SUPPORT DEVICES OR SYSTEMS WITHOUT THE EXPRESS WRITTEN APPROVAL OF THE PRESIDENT OF NATIONAL SEMICONDUCTOR CORPORATION. As used herein:

1. Life support devices or systems are devices or systems which, (a) are intended for surgical implant into the body, or (b) support or sustain life, and whose failure to perform, when properly used in accordance with instructions for use provided in the labeling, can be reasonably expected to result in a significant injury to the user.
2. A critical component is any component of a life support device or system whose failure to perform can be reasonably expected to cause the failure of the life support device or system, or to affect its safety or effectiveness.

	National Semiconductor Corporation Americas Tel: 1(800) 272-9959 Fax: 1(800) 737-7018 Email: support@nsc.com	National Semiconductor Europe Fax: +49 (0) 180-530 85 86 Email: europe.support@nsc.com Deutsch Tel: +49 (0) 180-530 85 85 English Tel: +49 (0) 180-532 78 32 Français Tel: +49 (0) 180-532 93 58 Italiano Tel: +49 (0) 180-534 16 80	National Semiconductor Southeast Asia Fax: (852) 2376 3901 Email: sea.support@nsc.com	National Semiconductor Japan Ltd. Tel: 81-3-5620-7561 Fax: 81-3-5620-6179
	http://www.national.com			

National does not assume any responsibility for use of any circuitry described, no circuit patent licenses are implied and National reserves the right at any time without notice to change said circuitry and specifications.