

### 150MHz Differential Twisted Pair Driver



The EL2140/2141 is a very high bandwidth amplifier whose output is in differential form, and is thus primarily targeted for applications such as driv-

ing twisted pair lines, or any application where common mode injection is likely to occur. The input signal can be in either single-ended or differential form, but the output is always in differential form.

On the EL2141, two feedback inputs provide the user with the ability to set the device gain, (stable at minimum gain of two), whereas the EL2140 comes with a fixed gain of two.

The output common mode level is set by the reference pin ( $V_{REF}$ ), which has a -3dB bandwidth of over 100MHz. Generally, this pin is grounded, but it can be tied to any voltage reference.

The transmission of ADSL/HDSL signals requires very low distortion amplification, so this amplifier was designed with this as a primary goal. The actual signal distortion levels depend upon input and output signal amplitude, as well as the output load impedance. (See distortion data inside.)

Both outputs ( $V_{OUT}$ ,  $V_{OUTB}$ ) are short circuit protected to withstand temporary overload condition.

### Ordering Information

PART NUMBER	TEMP. RANGE	PACKAGE	PKG. NO.
EL2140CN	-40°C to +85°C	8-pin PDIP	MDP0031
EL2140CS	-40°C to +85°C	8-pin SOIC	MDP0027
EL2141CN	-40°C to +85°C	8-pin PDIP	MDP0031
EL2141CS	-40°C to +85°C	8-pin SOIC	MDP0027

### Pinouts

**EL2140**  
(8-PIN SOIC, PDIP)  
TOP VIEW

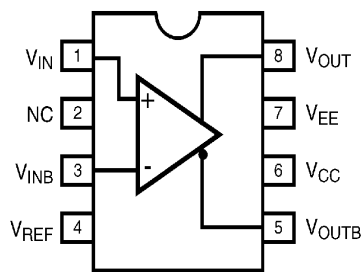

**EL2141**  
(8-PIN SOIC, PDIP)  
TOP VIEW

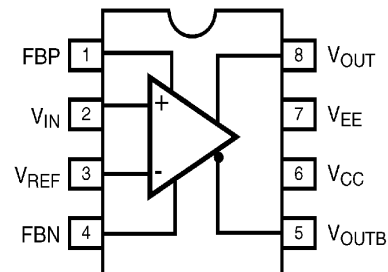

### Features

- Fully differential inputs, outputs, and feedback
- Differential input range  $\pm 2.3V$
- 150MHz 3dB bandwidth
- 800V/ $\mu s$  slew rate
- -55dB distortion at 3MHz
- -75dB distortion at 100kHz
- $\pm 5V$  supplies or +6V single supply
- 50mA minimum output current
- Output swing (200 $\Omega$  load) to within 1.5V of supplies (14V $_{PKPK}$  differential)
- Low power-11mA typical supply current

### Applications

- Twisted pair driver
- Differential line driver
- VGA over twisted pair
- ADSL/HDSL driver
- Single ended to differential amplification
- Transmission of analog signals in a noisy environment

## EL2140, EL2141

### Absolute Maximum Ratings ( $T_A = 25^\circ\text{C}$ )

Supply Voltage  $V_{S+}$  and GND . . . . . +12.6V  
 Maximum Output Current . . . . .  $\pm 60\text{mA}$   
 Storage Temperature Range . . . . .  $-65^\circ\text{C}$  to  $+150^\circ\text{C}$   
 Operating Junction Temperature . . . . .  $+150^\circ\text{C}$

Recommended Operating Temperature . . . . .  $-40^\circ\text{C}$  to  $85^\circ\text{C}$   
 $V_{IN}$ ,  $V_{INB}$ ,  $V_{REF}$  . . . . .  $V_{EE}+0.8\text{V}$  (MIN) to  $V_{CC}-0.8\text{V}$  (MAX)  
 $V_{IN}-V_{INB}$  . . . . .  $\pm 5\text{V}$

*CAUTION: Stresses above those listed in "Absolute Maximum Ratings" may cause permanent damage to the device. This is a stress only rating and operation of the device at these or any other conditions above those indicated in the operational sections of this specification is not implied.*

*IMPORTANT NOTE: All parameters having Min/Max specifications are guaranteed. Typical values are for information purposes only. Unless otherwise noted, all tests are at the specified temperature and are pulsed tests, therefore:  $T_J = T_C = T_A$*

### DC Electrical Specifications $V_{CC} = +5\text{V}$ , $V_{EE} = -5\text{V}$ , $T_A = 25^\circ\text{C}$ , $V_{IN} = 0\text{V}$ , $R_L = 200$ , unless otherwise specified.

PARAMETER	DESCRIPTION	MIN	TYP	MAX	UNITS
$V_{SUPPLY}$	Supply Operating Range ( $V_{CC}-V_{EE}$ )	$\pm 3.0$	$\pm 5.0$	$\pm 6.3$	V
$I_S$	Power Supply Current (No Load)		11	14	mA
$V_{OS}$	Input Referred Offset Voltage	-25	10	40	mV
$I_{IN}$	Input Bias Current ( $V_{IN}$ , $V_{INB}$ , $V_{REF}$ )	-20	6	20	$\mu\text{A}$
$Z_{IN}$	Differential Input Impedance		400		k $\Omega$
$V_{DIFF}$	Differential Input Range	$\pm 2.0$	$\pm 2.3$		V
$A_V$	Voltage Gain (EL2140) $V_{IN} = 2V_{PK-PK}$	1.95	1.985	2.02	V/V
$A_{VOL}$	Open Loop Voltage Gain (EL2141)		75		dB
$V_{CM}$	Input Common Mode Voltage Range (EL2140)	-2.6		+4.0	V
$V_{OUT(200)}$	Output Voltage Swing (200 $\Omega$ load, $V_{OUT}$ to $V_{OUTB}$ ) (EL2141)	$\pm 3.4$	$\pm 3.6$		V
$V_{OUT(100)}$	Output Voltage Swing (100 $\Omega$ Load, $V_{OUT}$ to $V_{OUTB}$ ) (EL2141)	$\pm 2.9$	$\pm 3.1$		V
$V_N$	Input Referred Voltage Noise		36		nV/ $\sqrt{\text{Hz}}$
$V_{REF}$	Output Voltage Control Range (EL2140)	-2.5		+3.3	V
$V_{REFOS}$	Output Offset Relative to $V_{REF}$	-60	-25	+60	mV
PSRR	Power Supply Rejection Ratio	60	70		dB
$I_{OUT(min)}$	Minimum Output Current	50	60		mA
CMRR	Input Common Mode Rejection Ratio (EL2140) $V_{CM} = \pm 2\text{V}$	60	70		dB
$R_{OUT}$	( $V_{OUT} = V_{OUTB} = 0\text{V}$ ) Output Impedance		0.1		$\Omega$

## EL2140, EL2141

### AC Electrical Specifications $V_{CC} = +5V$ , $V_{EE} = -5V$ , $T_A = 25^\circ C$ , $V_{IN} = 0V$ , $R_{LOAD} = 200$ , unless otherwise specified

PARAMETER	DESCRIPTION	MIN	TYP	MAX	UNITS
BW(-3dB)	-3dB Bandwidth (EL2140 and EL2141 @ gain of 2)		150		MHz
SR	Differential Slewrate		800		V/ $\mu$ s
Tstl	Settling Time to 1%		15		ns
GBW	Gain Bandwidth Product		400		MHz
$V_{REFBW}(-3dB)$	$V_{REF}$ -3dB Bandwidth		130		MHz
$V_{REFSR}$	$V_{REF}$ Slewrate		100		V/ $\mu$ s
THDf1	Distortion at 100kHz (Note 1)		-75		dB
dP	Differential Phase @ 3.58MHz		0.16		°
dG	Differential Gain @ 3.58MHz		0.24		%

**NOTE:**

- Distortion measurement quoted for  $V_{OUT} - V_{OUTB} = 12V$  pk-pk,  $R_{LOAD} = 200\Omega$ ,  $V_{GAIN} = 8$

### Pin Descriptions

PIN NO.		PIN NAME	FUNCTION
EL2140	EL2141		
1	2	$V_{IN}$	Non-inverting Input
3		$V_{INB}$	Inverting Input (EL2140 only)
	1	FBP	Non-inverting Feedback Input. Resistor R1 must be Connected from this Pin to $V_{OUT}$ . (EL2141 only)
	4	FBN	Inverting Feedback Input. Resistor R3 must be Connected from this pin to $V_{OUTB}$ . (EL2141 only)
4	3	$V_{REF}$	Output Common-mode Control. The Common-mode Voltage of $V_{OUT}$ and $V_{OUTB}$ will Follow the Voltage on this Pin. Note that on the EL2141, this pin is also the $V_{INB}$ pin.
5	5	$V_{OUTB}$	Inverting Output
6	6	$V_{CC}$	Positive Supply
7	7	$V_{EE}$	Negative Supply
8	8	$V_{OUT}$	Non-inverting Output

Typical Performance Curves

I<sub>S</sub> vs Supply Voltage

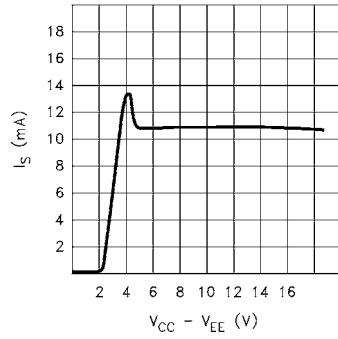

EL2140 Frequency Response

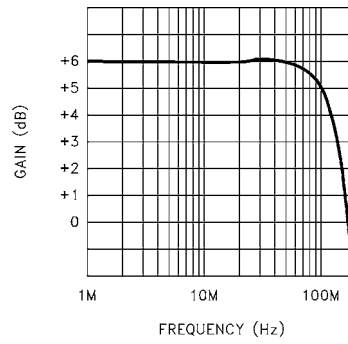

EL2141 Frequency Response vs Resistor R2 (Gain = 2)

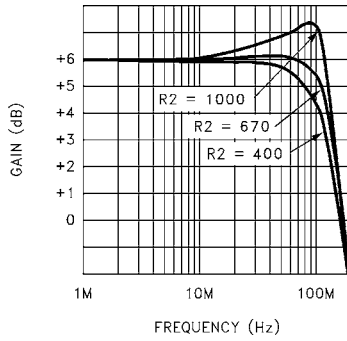

Frequency Response vs Temperature

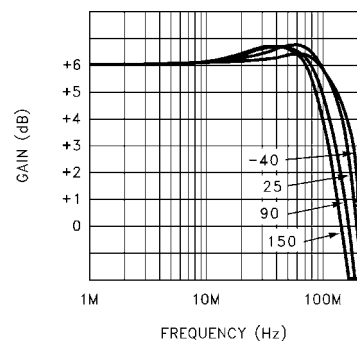

EL2141 Frequency Response vs Resistor R2 (Gain = 8)

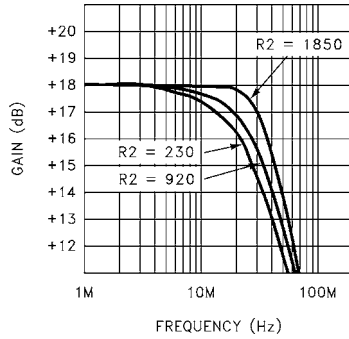

EL2141 Distortion vs Frequency (Gain = 6, R<sub>LOAD</sub> = 200Ω, V<sub>IN</sub> = 2V<sub>PK-PK</sub>)

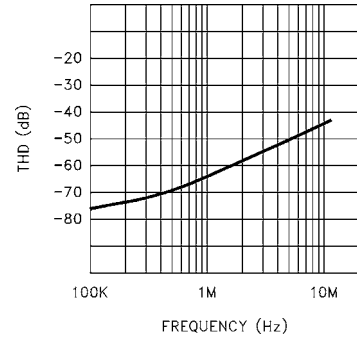

Typical Performance Curves (Continued)

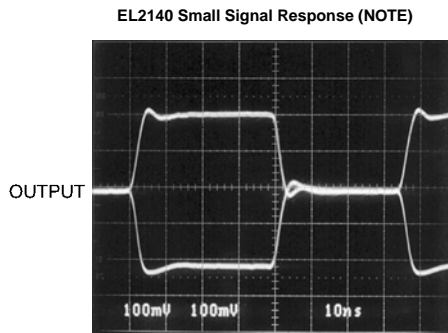
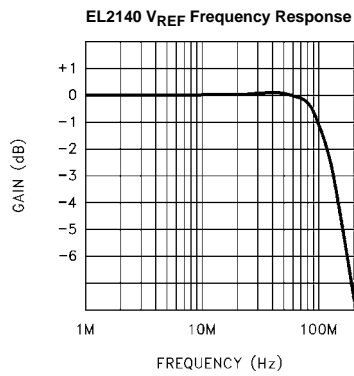
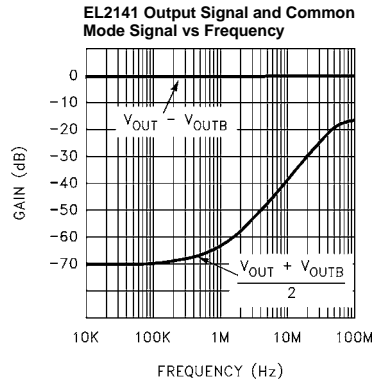
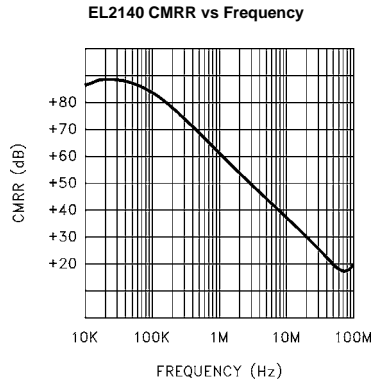

NOTE: Photo Shows Voltages On A 100Ω Transmission Line Terminated At Both Ends, So Voltages At  $V_{OUT}$ ,  $V_{OUTB}$  Are Twice The Values Shown.

## Applications Information

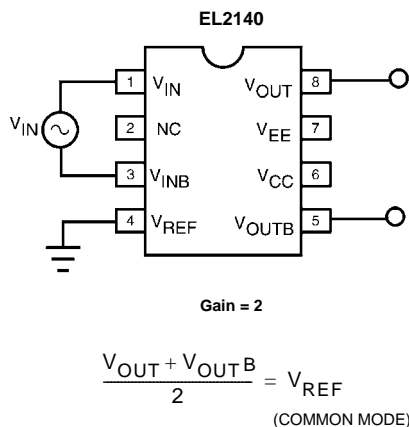
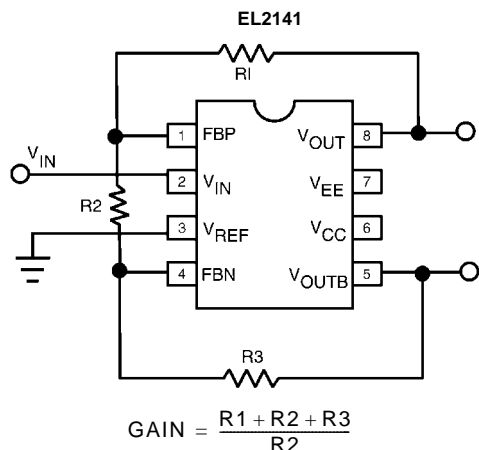

### Choice of Feedback Resistor

There is little to be gained from choosing resistor R2 values below 400Ω and, in fact, it would only result in increased power dissipation and signal distortion. Above 400Ω, the bandwidth response will develop some peaking (for a gain of two), but substantially higher resistor R2 values may be used for higher voltage gains, such as up to 2kΩ at a gain of eight before peaking will develop. R1 and R3 are selected as needed to set the voltage gain, and while R1 = R3 is suggested, the gain equation above holds for any values (see distortion for further suggestions).

### Capacitance Considerations

As with many high bandwidth amplifiers, the EL2140/2141 prefer not to drive highly capacitive loads. It is best if the capacitance on V<sub>OUT</sub> and V<sub>OUTB</sub> is kept below 10pF if the user does not want gain peaking to develop.

In addition, on the EL2141, the two feedback nodes FBP and FBN should be laid out so as to minimize stray capacitance, else an additional pole will potentially develop in the response with possible gain peaking.

The amount of capacitance tolerated on any of these nodes in an actual application will also be dependent on the gain setting and the resistor values in the feedback network.

### Distortion Considerations

The harmonics that these amplifiers will potentially produce are the 2nd, 3rd, 5th, and 6th. Their amplitude is application dependent. All other harmonics should be negligible by comparison. Each should be considered separately:

**H2** The second harmonic arises from the input stage, and the lower the applied differential signal amplitude, the lower the magnitude of the second harmonic. For practical considerations of required output signal and input noise levels, the user will end up choosing a circuit gain. Referring to Figure 1, it is best if the voltage at the negative feedback node tracks the V<sub>REF</sub> node, and the voltage at the positive feedback node tracks the V<sub>IN</sub> node respectively. This would theoretically require that R1 + R2 = R3, although the lowest distortion is found at about R3 = R1 + (0.7\*R2). With this

arrangement, the second harmonic should be suppressed well below the value of the third harmonic.

**H3** The third harmonic should be the dominant harmonic and is primarily affected by output load current which, of course, is unavoidable. However, this should encourage the user not to waste current in the gain setting resistors, and to use values that consume only a small proportion of the load current, so long as peaking does not occur. The more load current, the worse the distortion, but depending on the frequency, it may be possible to reduce the amplifier gain so that there is more internal gain left to cancel out any distortion.

**H5** The fifth harmonic should always be below the third, and will not become significant until heavy load currents are drawn. Generally, it should respond to the same efforts applied to reducing the third harmonic.

**H6** The sixth harmonic should not be a problem and is the result of poor power supply decoupling. While 100nF chip capacitors may be sufficient for some applications, it would be insufficient for driving full signal swings into a twisted pair line at 100kHz. Under these conditions, the addition of 4.7μF tantalum capacitors would cure the problem.

Typical Applications Circuits

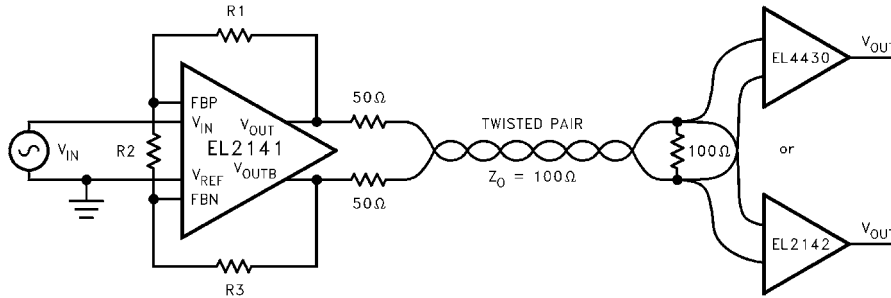

FIGURE 1. TYPICAL TWISTED PAIR APPLICATION

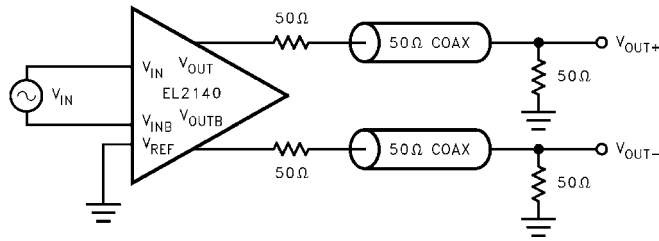

FIGURE 2. DUAL COAXIAL CABLE DRIVER

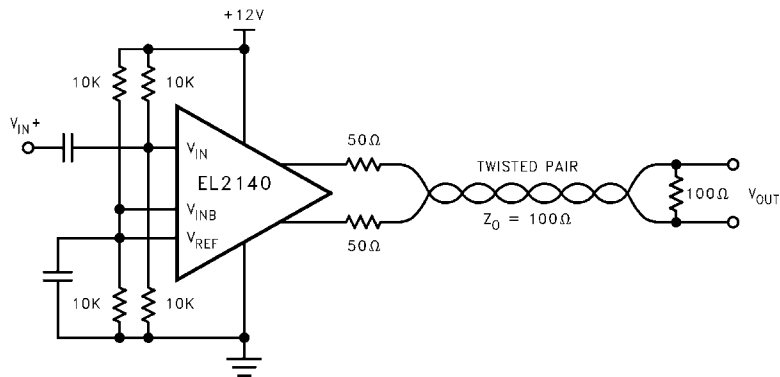

FIGURE 3. SINGLE SUPPLY TWISTED PAIR DRIVER

Typical Applications Circuits (Continued)

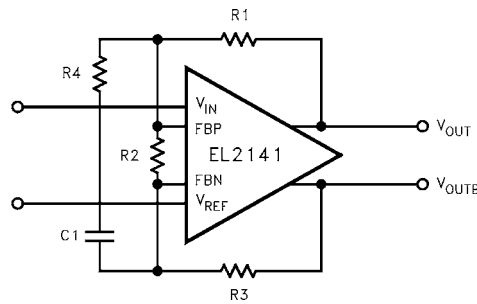
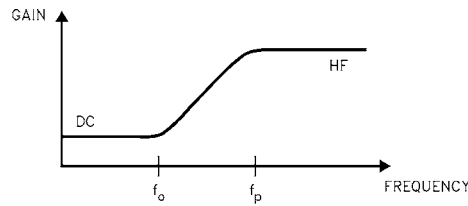

FIGURE 4. DIFFERENTIAL LINE DRIVER WITH EQUALIZATION

$$\text{DCGain} = \frac{R1 + R2 + R3}{R2} \text{ (See Figure 5)}$$

$$\text{(HF)Gain} = \frac{R1 + (R2/R4) + R3}{(R2/R4)} \text{ (See Figure 5)}$$



$$\text{where } F_o = \frac{1}{2\pi C_1 R_2}$$

$$\text{and } F_p = \frac{1}{2\pi C_1 R_4}$$

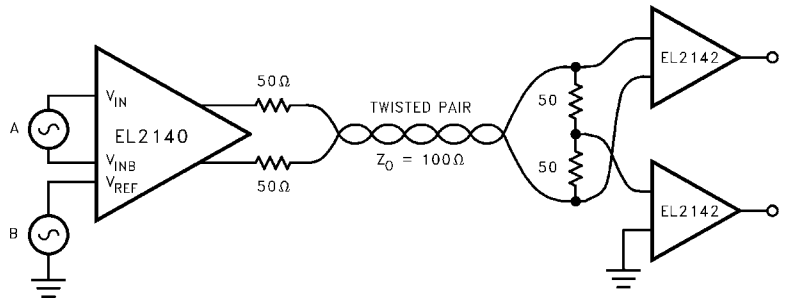

FIGURE 5. DUAL SIGNAL TRANSMISSION CIRCUIT

All Intersil U.S. products are manufactured, assembled and tested utilizing ISO9000 quality systems. Intersil Corporation's quality certifications can be viewed at [www.intersil.com/design/quality](http://www.intersil.com/design/quality)

*Intersil products are sold by description only. Intersil Corporation reserves the right to make changes in circuit design, software and/or specifications at any time without notice. Accordingly, the reader is cautioned to verify that data sheets are current before placing orders. Information furnished by Intersil is believed to be accurate and reliable. However, no responsibility is assumed by Intersil or its subsidiaries for its use; nor for any infringements of patents or other rights of third parties which may result from its use. No license is granted by implication or otherwise under any patent or patent rights of Intersil or its subsidiaries.*

For information regarding Intersil Corporation and its products, see [www.intersil.com](http://www.intersil.com)