

FEATURES

- **UL Rated Isolated RS485: 2500V_{RMS}**
- Half- or Full-Duplex
- **Eliminates Ground Loops**
- **350kBd Maximum Data Rate**
- **Self-Powered with 400kHz Converter**
- Fail-Safe Output High for Open or Shorted Receiver Inputs
- Short-Circuit Current Limit
- Slow Slew Rate Control
- 68kΩ Input Impedance Allows Up to 128 Nodes
- Thermal Shutdown
- 8kV ESD Protection On Driver Outputs and Receiver Inputs

APPLICATIONS

- Isolated RS485 Receiver/Driver
- RS485 with Large Common Mode Voltage
- Breaking RS485 Ground Loops
- Multiple Unterminated Line Taps

DESCRIPTION

The LTC[®]1535 is an isolated RS485 full-duplex differential line transceiver. Isolated RS485 is ideal for systems where the ground loop is broken to allow for much larger common mode voltage ranges. An internal capacitive isolation barrier provides 2500V_{RMS} of isolation between the line transceiver and the logic level interface. The powered side contains a 400kHz push-pull converter to power the isolated RS485 transceiver. Internal full-duplex communication occurs through the capacitive isolation barrier. The transceiver meets RS485 and RS422 requirements.

The driver and receiver feature three-state outputs, with the driver maintaining high impedance over the entire common mode range. The drivers have short-circuit current limits in both directions and a slow slew rate select to minimize EMI or reflections. The 68kΩ receiver input allows up to 128 node connections. A fail-safe feature defaults to a high output state when the receiver inputs are open or shorted.

LT, LTC and LT are registered trademarks of Linear Technology Corporation.

TYPICAL APPLICATION

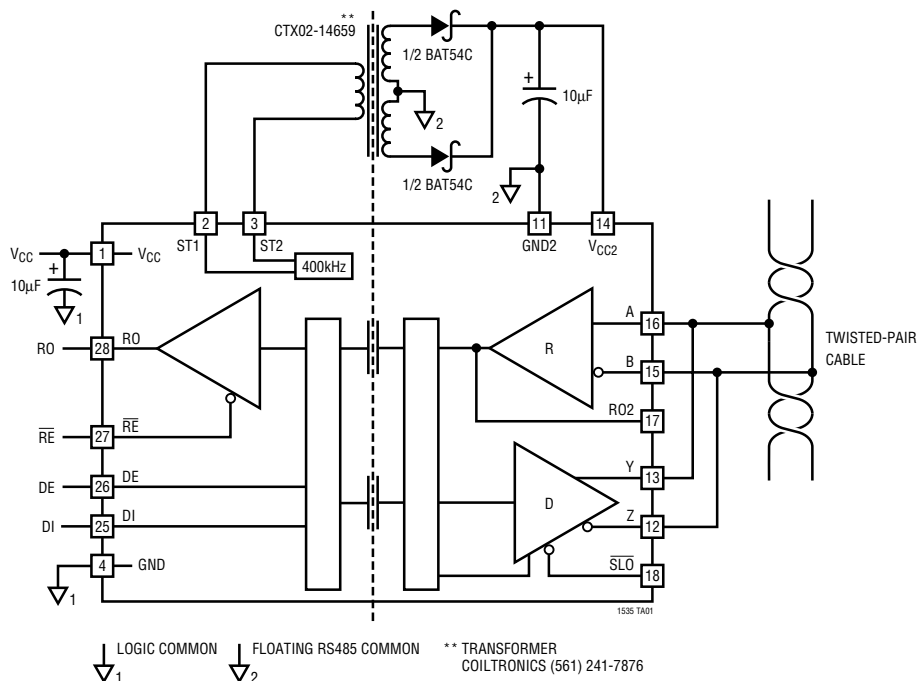

ABSOLUTE MAXIMUM RATINGS

(Note 1)

V_{CC} to GND	6V
V_{CC2} to GND2	8V
Control Input Voltage to GND	-0.3V to ($V_{CC} + 0.3V$)
Driver Input Voltage to GND	-0.3V to ($V_{CC} + 0.3V$)
Driver Output Voltage (Driver Disabled) to GND2	($V_{CC2} - 13V$) to 13V
Driver Output Voltage (Driver Enabled) to GND2	($V_{CC2} - 13V$) to 10V
Receiver Input Voltage to GND2	$\pm 14V$
Receiver Output Voltage	-0.3V to ($V_{CC} + 0.3V$)
Operating Temperature Range	$0^{\circ}C \leq T_A \leq 70^{\circ}C$
Lead Temperature (Soldering, 10 sec)	$300^{\circ}C$

PACKAGE/ORDER INFORMATION

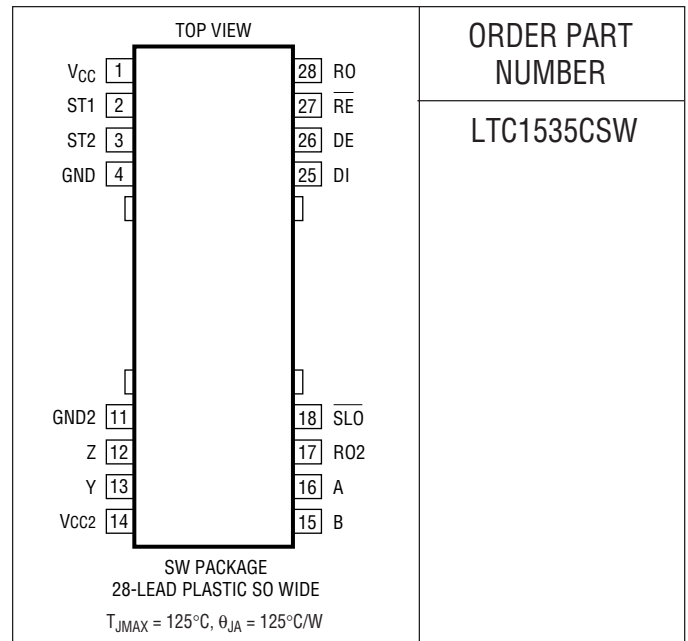

ORDER PART NUMBER

LTC1535CSW

Consult factory for Industrial and Military grade parts.

ELECTRICAL CHARACTERISTICS

The ● denotes the specifications which apply over the full operating temperature range, otherwise specifications are at $T_A = 25^{\circ}C$. $0^{\circ}C \leq T_A \leq 70^{\circ}C$, $V_{CC} = 5V$, $V_{CC2} = 5V$ unless otherwise noted.

SYMBOL	PARAMETER	CONDITIONS	MIN	TYP	MAX	UNITS	
V_{CC}	V_{CC} Supply Range		● 4.5		5.5	V	
V_{CC2}	V_{CC2} Supply Range		● 4.5		7.5	V	
I_{CC}	V_{CC} Supply Current	No Load	●	13	18	mA	
I_{CC2}	V_{CC2} Supply Current	R = 27 Ω , Figure 1	●	63	73	mA	
		No Load	●	7	12	mA	
V_{OD1}	Differential Driver Output	No Load	●		5	V	
V_{OD2}	Differential Driver Output	R = 50 Ω (RS422) Note 2	●	2		V	
		R = 27 Ω (RS485), Figure 1	●	1.5	2	V	
I_{OSD1}	Driver Short-Circuit Current $V_{OUT} = \text{HIGH}$ $V_{OUT} = \text{LOW}$	$-7V \leq V_{CM} \leq 10V$	●	75	100	135	mA
		$-7V \leq V_{CM} \leq 10V$	●	75	100	135	mA
V_{IH}	Logic Input High Voltage	DE, DI, \overline{RE} $V_{CC} = 4.5V$	●	2		V	
V_{IL}	Logic Input Low Voltage	DE, DI, \overline{RE} $V_{CC} = 4.5V$	●		0.8	V	
I_{IN}	Input Current (A, B)	Note 3			0.25	mA	
		$V_{IN} = 12V$	●		-0.20	mA	
		$V_{IN} = -7V$	●			mA	
V_{TH}	Receiver Input Threshold	$-7V \leq V_{CM} \leq 12V$, Note 4	●	-200	-90	-10	mV
ΔV_{TH}	Receiver Input Hysteresis	$-7V \leq V_{CM} \leq 12V$	●	10	30	70	mV
R_{IN}	Receiver Input Impedance		●	50	68	85	k Ω
V_{OH}	RO Output High Voltage	$I_{RO} = -4mA$, $V_{CC} = 4.5V$	●	3.7	4.0		V
		$I_{RO} = -10mA$, $V_{CC} = 4.5V$			3.4		V
V_{OL}	RO Output Low Voltage	$I_{RO} = 4mA$, $V_{CC} = 4.5V$	●		0.4	0.8	V
		$I_{RO} = 10mA$, $V_{CC} = 4.5V$			0.9		V

ELECTRICAL CHARACTERISTICS

The ● denotes the specifications which apply over the full operating temperature range, otherwise specifications are at $T_A = 25^\circ\text{C}$. $0^\circ\text{C} \leq T_A \leq 70^\circ\text{C}$, $V_{CC} = 5\text{V}$, $V_{CC2} = 5\text{V}$ unless otherwise noted.

SYMBOL	PARAMETER	CONDITIONS	MIN	TYP	MAX	UNITS
I_{OZ}	Driver Output Leakage			1		μA
V_{OH2}	RO2 Output High Voltage	$I_{RO2} = -4\text{mA}$, $V_{CC} = 4.5\text{V}$ $I_{RO2} = -10\text{mA}$, $V_{CC} = 4.5\text{V}$	● 3.7	3.9 3.4		V V
V_{OL2}	RO2 Output Low Voltage	$I_{RO2} = 4\text{mA}$, $V_{CC} = 4.5\text{V}$ $I_{RO2} = 10\text{mA}$, $V_{CC} = 4.5\text{V}$	●	0.4 0.9	0.8	V V
f_{SW}	DC Converter Frequency		● 290	420	520	kHz
R_{SWH}	DC Converter R High	$V_{CC} = 4.5\text{V}$	●	4	6	Ω
R_{SWL}	DC Converter R Low	$V_{CC} = 4.5\text{V}$	●	2.5	5	Ω
I_{REL}	\overline{RE} Output Low Current	\overline{RE} Sink Current, Fault = 0	● -40	-50	-80	μA
I_{REH}	\overline{RE} Output High Current	\overline{RE} Source Current, Fault = 1	● 80	100	130	μA
V_{UVL}	Undervoltage Low Threshold	\overline{RE} Fault = 1, Note 5	● 3.90	4.00	4.25	V
V_{UVH}	Undervoltage High Threshold	\overline{RE} Fault = 0, Note 5	● 4.05	4.20	4.40	V
V_{ISO}	Isolation Voltage	1 Minute, Note 6 1 Second	2500 3000			V_{RMS} V_{RMS}

SWITCHING CHARACTERISTICS

The ● denotes the specifications which apply over the full operating temperature range, otherwise specifications are at $T_A = 25^\circ\text{C}$. $0^\circ\text{C} \leq T_A \leq 70^\circ\text{C}$, $V_{CC} = 5\text{V}$, $V_{CC2} = 5\text{V}$, $R = 27\Omega$ (RS485) unless otherwise noted.

SYMBOL	PARAMETER	CONDITIONS	MIN	TYP	MAX	UNITS
t_{SJ}	Data Sample Jitter	Figure 8, Note 7	●	250	285	ns
f_{MAX}	Max Baud Rate	Jitter = 10% Max, $\overline{SLO} = 1$, Note 8	● 350			kBd
t_{PLH}	Driver Input to Output	$DE = 1$, $\overline{SLO} = 1$, Figure 3, Figure 5 $DE = 1$, $\overline{SLO} = 0$, Figure 3, Figure 5	● ●	600 1300	855 1560	ns ns
t_{PHL}	Driver Input to Output	$DE = 1$, $\overline{SLO} = 1$, Figure 3, Figure 5 $DE = 1$, $\overline{SLO} = 0$, Figure 3, Figure 5	● ●	600 1300	855 1560	ns ns
t_r, t_f	Driver Rise or Fall Time	$DE = 1$, $\overline{SLO} = 1$, Figure 3, Figure 5 $DE = 1$, $\overline{SLO} = 0$	● ●	20 500	50 1000	ns ns
t_{ZH}	Driver Enable to Output	$DI = 1$, $\overline{SLO} = 1$, Figure 4, Figure 6	●	1000	1400	ns
t_{ZL}	Driver Enable to Output	$DI = 0$, $\overline{SLO} = 1$, Figure 4, Figure 6	●	1000	1400	ns
t_{LZ}	Driver Disable to Output	$DI = 0$, $\overline{SLO} = 1$, Figure 4, Figure 6	●	700	1000	ns
t_{HZ}	Driver Disable to Output	$DI = 1$, $\overline{SLO} = 1$, Figure 4, Figure 6	●	700	1000	ns
t_{PLH}	Receiver Input to RO	$\overline{RE} = 0$, Figure 2, Figure 7	●	600	855	ns
t_{PHL}	Receiver Input to RO	$\overline{RE} = 0$, Figure 2, Figure 7	●	600	855	ns
t_{PLH}	Receiver Input to RO2	$\overline{RE} = 0$, Figure 2, Figure 7		30		ns
t_{PHL}	Receiver Input to RO2	$\overline{RE} = 0$, Figure 2, Figure 7		30		ns
t_r, t_f	Receiver Rise or Fall Time	$\overline{RE} = 0$, Figure 2, Figure 7		20		ns
t_{LZ}	Receiver Disable to Output	Figure 2, Figure 8		30		ns
t_{HZ}	Receiver Disable to Output	Figure 2, Figure 8		30		ns
t_{START}	Initial Start-Up Time	Note 9		1200		ns
t_{TOF}	Data Time-Out Fault	Note 9		1200		ns

ELECTRICAL CHARACTERISTICS

Note 1: Absolute Maximum Ratings are those values beyond which the life of a device may be impaired.

Note 2: RS422 50Ω specification based on RS485 27Ω test.

Note 3: I_{IN} is tested at $V_{CC2} = 5V$, guaranteed by design from $V_{CC2} = GND2 \leq 5.25V$.

Note 4: Input fault conditions on the RS485 receiver are detected with a fixed receiver offset. The offset is such that an input short or open will result in a high data output.

Note 5: The low voltage detect faults when V_{CC2} or V_{CC} drops below 4.2V and reenables when greater than 4.4V. The fault can be monitored through the weak driver output on \overline{RE} .

Note 6: Value derived from 1 second test.

Note 7: The input signals are internally sampled and encoded. The internal sample rate determines the data output jitter since the internal sampling is asynchronous with respect to the external data. Nominally, a 4MHz internal sample rate gives 250ns of sampling uncertainty in the input signals.

Note 8: The maximum baud rate is 350kBd with 10% sampling jitter. Lower baud rates have lower jitter.

Note 9: Start-up time is the time for communication to recover after a fault condition. Data time-out is the time a fault is indicated on \overline{RE} after data communication has stopped.

PIN FUNCTIONS

POWER SIDE

V_{CC} (Pin 1): 5V Supply. Bypass to GND with 10μF capacitor.

ST1 (Pin 2): DC Converter Output 1 to DC Transformer.

ST2 (Pin 3): DC Converter Output 2 to DC Transformer.

GND (Pin 4): Ground.

DI (Pin 25): Transmit Data TTL Input to the Isolated Side RS485 Driver. Do not float.

DE (Pin 26): Transmit Enable TTL Input to the Isolated Side RS485 Driver. A high level enables the driver. Do not float.

\overline{RE} (Pin 27): Receive Data Output Enable TTL Input. A low level enables the receiver. This pin also provides a fault output signal. (See Applications Information.)

RO (Pin 28): Receive Data TTL Output.

ISOLATED SIDE

GND2 (Pin 11): Isolated Side Power Ground.

Z (Pin 12): Differential Driver Inverting Output.

Y (Pin 13): Differential Driver Noninverting Output.

V_{CC2} (Pin 14): 5V to 7.5V Supply from DC Transformer. Bypass to GND with 10μF capacitor.

B (Pin 15): Differential Receiver Inverting Input.

A (Pin 16): Differential Receiver Noninverting Input.

RO2 (Pin 17): Isolated Side Receiver TTL Output.

\overline{SLO} (Pin 18): Slow Slew Rate Control of RS485 Driver. A low level forces the driver outputs into slow slew rate mode.

SWITCHING TIME WAVEFORMS

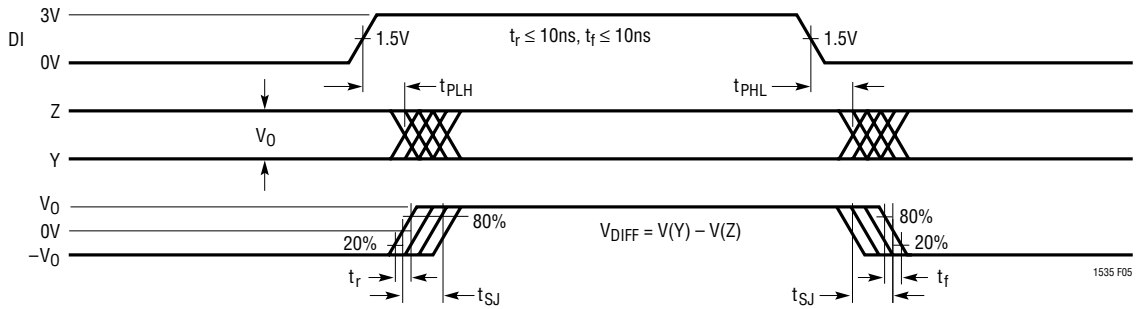

Figure 5. Driver Propagation Delays

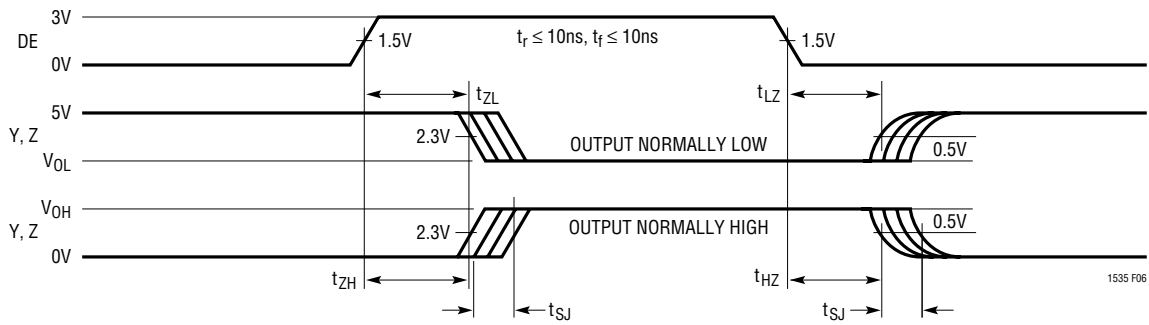

Figure 6. Driver Enable and Disable Times

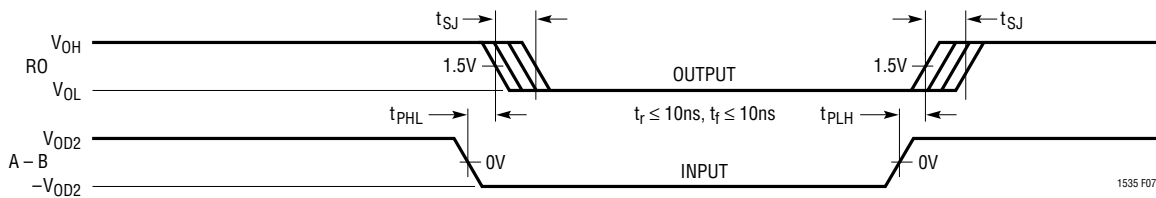

Figure 7. Receiver Propagation Delays

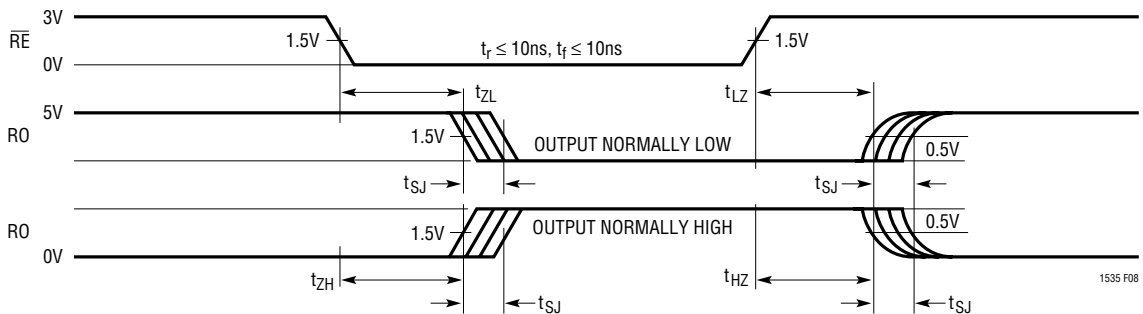

Figure 8. Receiver Enable and Disable Times

APPLICATIONS INFORMATION

Isolation Barrier and Sampled Communication

The LTC1535 uses the SW-28 isolated lead frame package to provide capacitive isolation barrier between the logic interface and the RS485 driver/receiver pair. The barrier provides 2500V_{RMS} of isolation. Communication between the two sides uses the isolation capacitors in a multiplexed way to communicate full-duplex data across this barrier. The data is sampled and encoded before transmitting across the isolation barrier, which will add sampling jitter and delay to the signals. The sampling jitter is approximately 250ns with a nominal delay of 600ns. At 250kBd rate, this represents 6.2% total jitter. The nominal DE signal to the driver output delay is 875ns ±125ns, which is longer due to the encoding. Communication start-up time is approximately 1μs to 2μs. A time-out fault will occur if communication from the isolated side fails. Faults can be monitored on the RE pin.

Push-Pull DC/DC Converter

The powered side contains a full-bridge open-loop driver, optimized for use with a single primary and center-tapped secondary transformer. Figure 9 shows the DC/DC converter in a configuration that can deliver up to 100mA of current to the isolated side using a Coiltronics CTX02-14659 transformer.

Because the DC/DC converter is open-loop, care in choosing low impedance parts is important for good regulation. Care must also be taken to not exceed the V_{CC2} recommended maximum voltage of 7.5V when there is very light loading. The isolated side contains a low voltage detect circuit to ensure that communication across the barrier will only occur when there is sufficient isolated supply voltage. If the output of the DC/DC converter is overloaded, the supply voltage will trip the low voltage detection at 4.2V. For higher voltage stand-off, the Coiltronics CTX02-14608 transformer may be used.

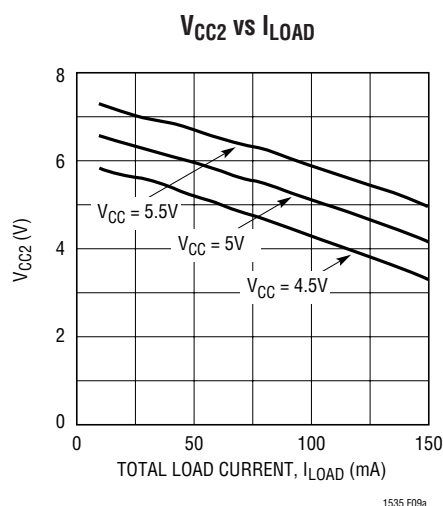
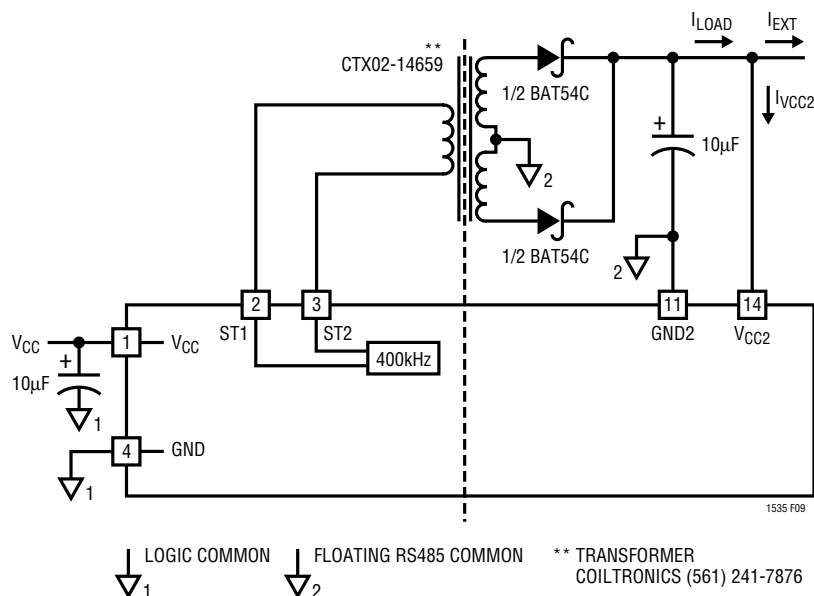

Figure 9

APPLICATIONS INFORMATION

Driver Output and Slow Slew Rate Control

The LTC1535 uses a proprietary driver output stage that allows a common mode voltage range that extends beyond the power supplies. Thus, the high impedance state is maintained over the full RS485 common mode range. The output stage provides 100mA of short-circuit current limiting in both the positive and negative directions. Thus, even under short-circuit conditions, the supply voltage from the open-loop DC converter will not be pulled too low to prevent proper communication across the isolation barrier. The driver output will be disabled in the event of a thermal shutdown and a fault condition will be indicated through the \overline{RE} weak output.

The CMOS level \overline{SLO} pin selects slow or fast slew rates on the RS485 driver output. The \overline{SLO} input has an internal 100k pull-up resistor. When \overline{SLO} is low, the driver outputs are slew rate limited to reduce high frequency edges. Left open or tied high, \overline{SLO} defaults to fast edges. The part draws more current during slow slew rate edges.

Monitoring Faults on \overline{RE}

The \overline{RE} pin can be used to monitor the following fault conditions: low supply voltages, thermal shutdown or a time-out fault when there is no data communication across the barrier. Open circuit or short-circuit conditions on the twisted pair do not cause a fault indication. However, the RS485 receiver defaults to a high output state when the receiver input is open or short-circuited.

The \overline{RE} pin has a weak current drive output mode for indicating fault conditions. This fault state can be polled using the circuit in Figure 10 where the control to \overline{RE} is three-stated and the fault condition read back from the \overline{RE} pin. The weak drive has 100 μ A pull-up current to indicate a fault and 50 μ A pull-down current for no fault. This allows the \overline{RE} pin to be polled without disabling \overline{RE} on nonfault conditions.

Both sides contain a low voltage detect circuit. A voltage less than 4.2V on the isolated side disables communication.

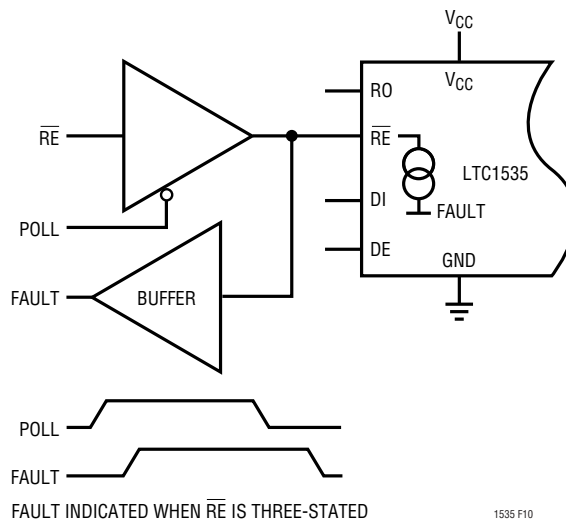

Figure 10. Detecting Fault Conditions

APPLICATIONS INFORMATION

High Voltage Considerations

The LTC1535 eliminates ground loops on data communication lines. However, such isolation can bring potentially dangerous voltages onto the circuit board. An example would be accidental faulting to 117V AC at some point on the cable which is then conducted to the PC board. Figure 11 shows how to detect and warn the user or installer that a voltage fault condition exists on the twisted pair or its shield. A small (3.2mm) glow lamp is connected between GND2 (the isolated ground) and the equipment's safety "earth" ground. If a potential of more than 75V AC is present on the twisted pair or shield, B1 will light, indicating a wiring fault. Resistors R3 and R4 are used to

ballast the current in B1. Two resistors are necessary because they can only stand off 200V each, as well as for power dissipation. As shown, the circuit can withstand a direct fault to a 440V 3Ø system.

Other problems introduced by floating the twisted pair include the collection of static charge on the twisted pair, its shield and the attached circuitry. Resistors R1 and R2 provide a path to shunt static charge safely to ground. Again, two resistors are necessary to withstand high voltage faults. Electrostatic spikes and transients can be limited by the addition of capacitor C1 and discharged through R1–R4.

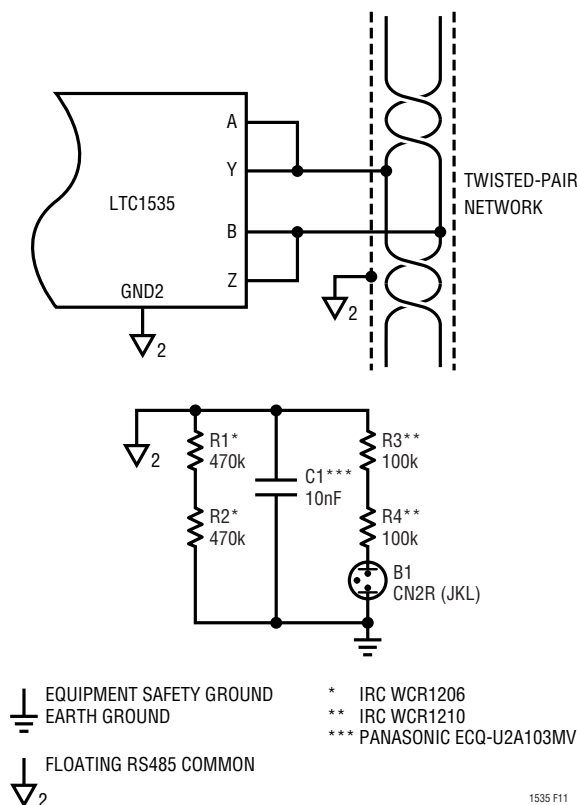

Figure 11. Detecting Wiring Faults

APPLICATIONS INFORMATION

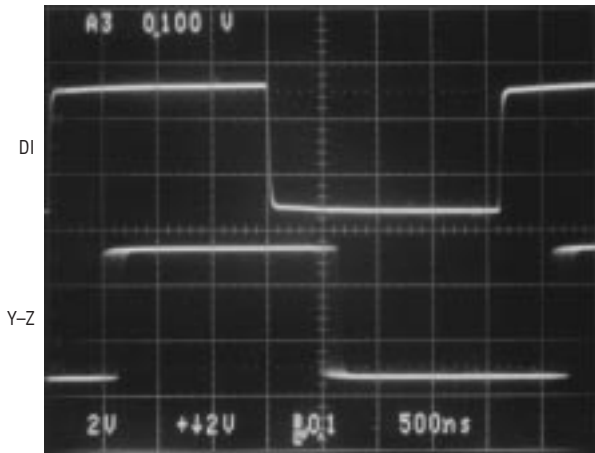

Figure 12. Driver Propagation Delay with Sample Jitter. $\overline{SLO} = V_{CC2}$

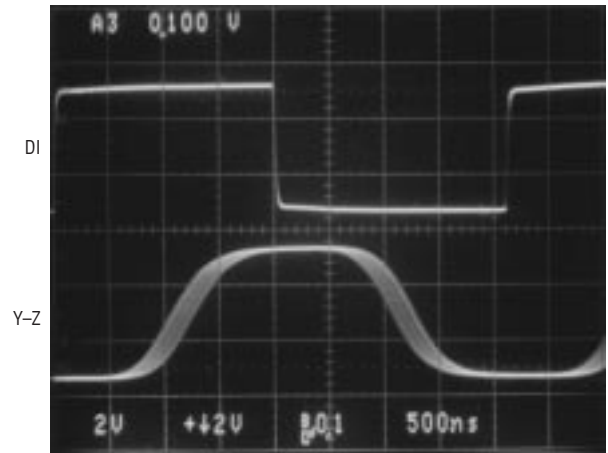

Figure 13. Driver Propagation Delay with Sample Jitter. $\overline{SLO} = 0V$

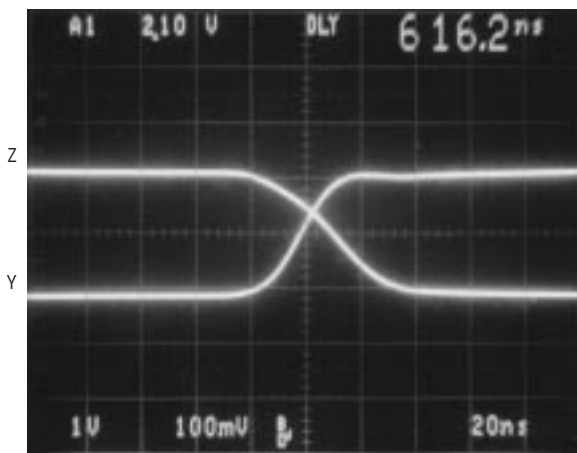

Figure 14. Driver Output. $R = 27\Omega$, $V_{CC2} = 5V$, $\overline{SLO} = V_{CC2}$

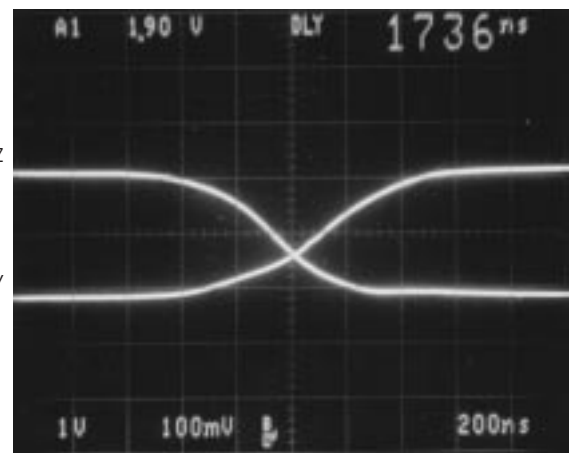

Figure 15. Driver Output. $R = 27\Omega$, $V_{CC2} = 5V$, $\overline{SLO} = 0V$

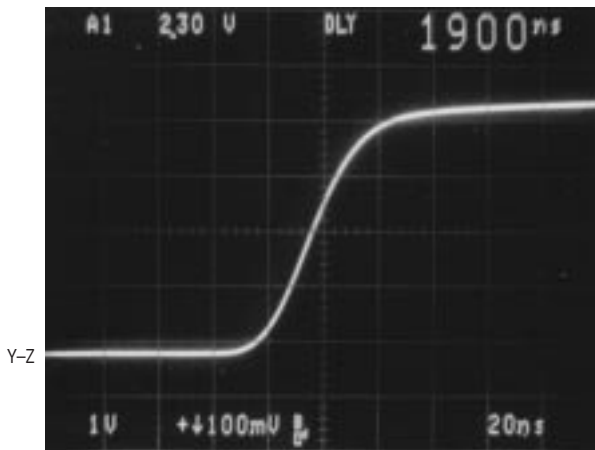

Figure 16. Driver Differential Output. $R = 27\Omega$, $V_{CC2} = 5V$, $\overline{SLO} = V_{CC2}$

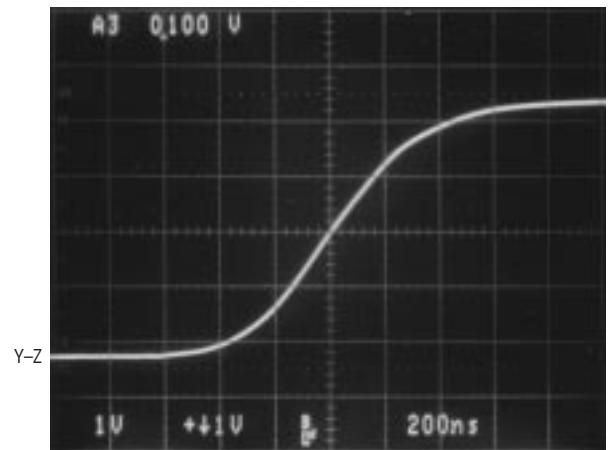
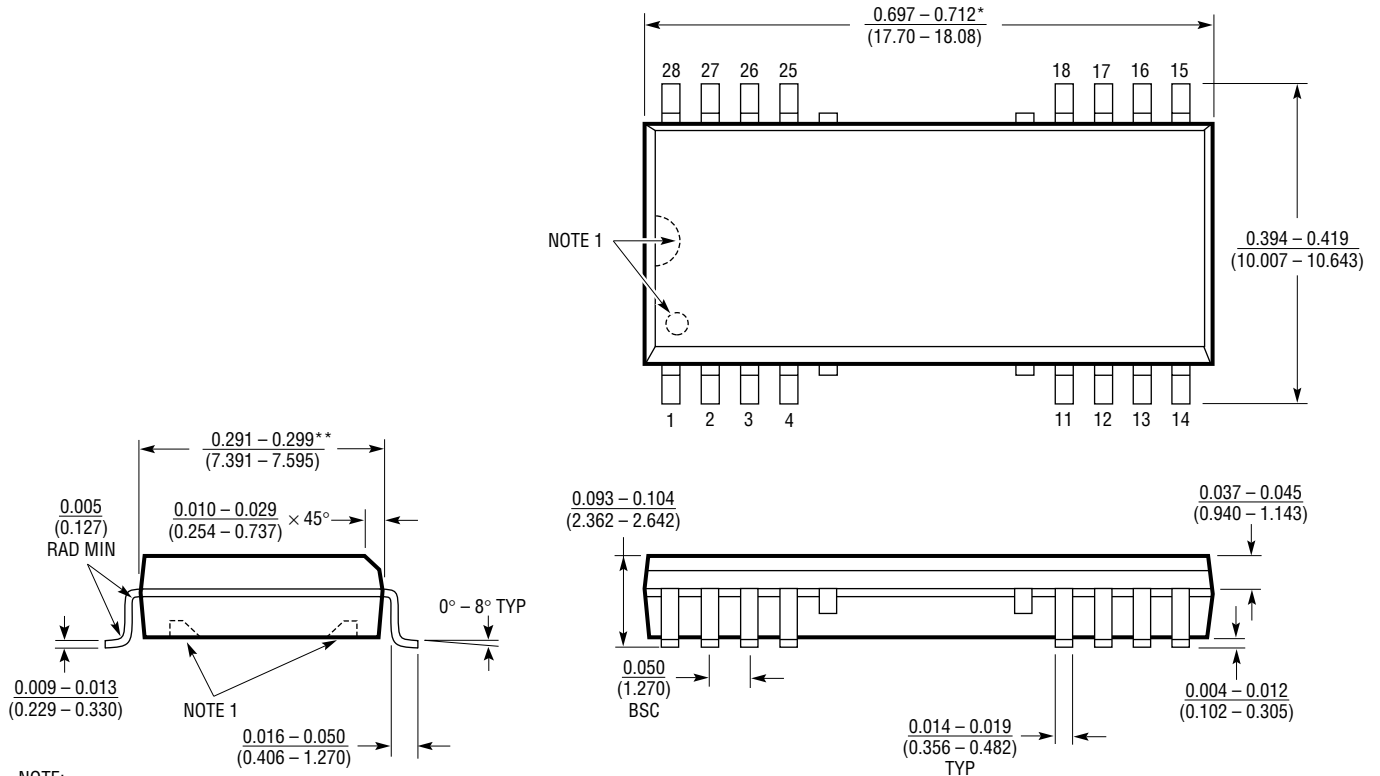

Figure 17. Driver Differential Output. $R = 27\Omega$, $V_{CC2} = 5V$, $\overline{SLO} = 0V$

PACKAGE DESCRIPTION Dimensions in inches (millimeters) unless otherwise noted.

SW Package
28-Lead Plastic Small Outline Isolation Barrier (Wide 0.300)
 (LTC DWG # 05-08-1690)



NOTE:
 1. PIN 1 IDENT, NOTCH ON TOP AND CAVITIES ON THE BOTTOM OF PACKAGES ARE THE MANUFACTURING OPTIONS
 THE PART MAY BE SUPPLIED WITH OR WITHOUT ANY OF THE OPTIONS.

SW28 (ISO) 1098

*DIMENSION DOES NOT INCLUDE MOLD FLASH. MOLD FLASH SHALL NOT EXCEED 0.006" (0.152mm) PER SIDE
 **DIMENSION DOES NOT INCLUDE INTERLEAD FLASH. INTERLEAD FLASH SHALL NOT EXCEED 0.010" (0.254mm) PER SIDE

TYPICAL APPLICATION

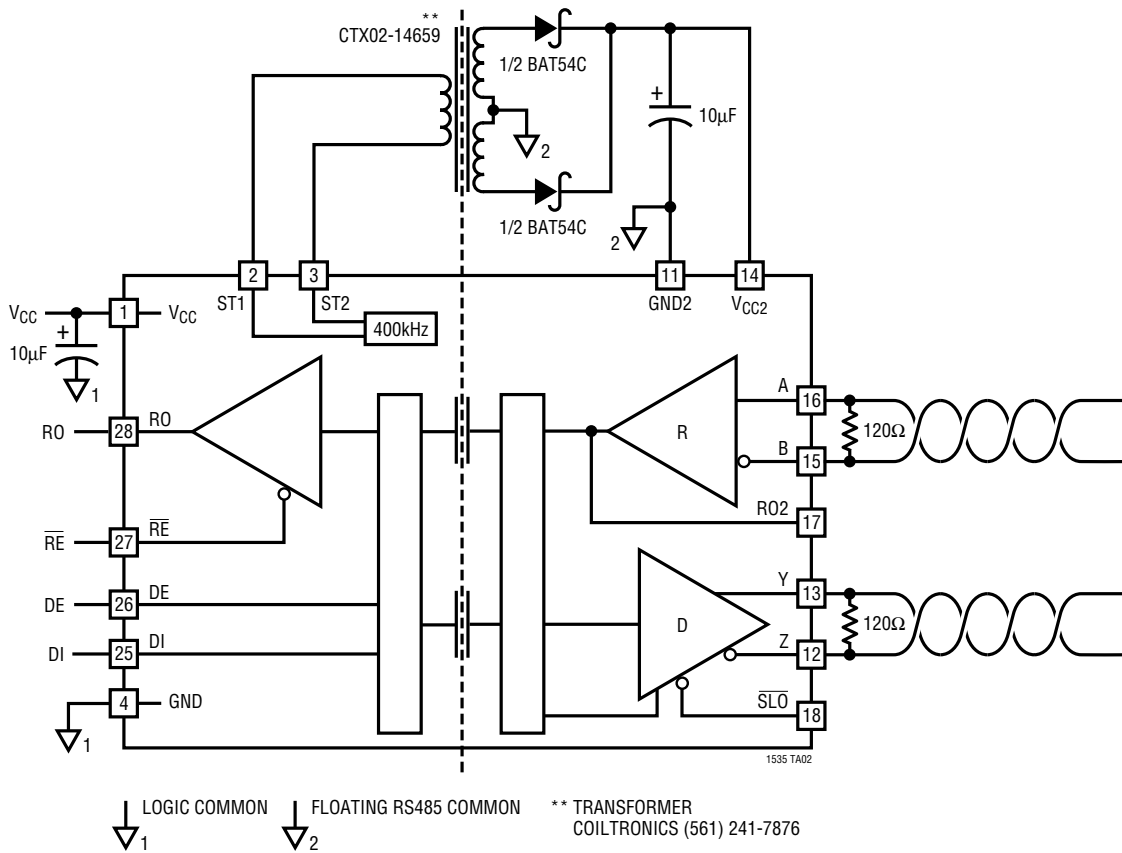

Figure 18. Full-Duplex Connection

RELATED PARTS

PART NUMBER	DESCRIPTION	COMMENTS
LTC1177	Isolated MOSFET Driver	No Secondary Supply, 2500V _{RMS} Isolation
LT1424-5	Isolated Flyback Switching Regulator	±5% Accurate with No Optoisolator Required
LTC1485	High Speed RS485 Transceiver	10Mbps, Pin Compatible with LTC485
LTC1531	Self-Powered Isolated Comparator	2.5V Isolated Reference, 3000V _{RMS} Isolation
LT1785/LT1791	±60V Fault Protected RS485 Transceiver, Half/Full-Duplex	±15kV ESD Protection, Industry Standard Pinout
LTC1690	Full-Duplex RS485 Transceiver	±15kV ESD Protection, Fail-Safe Receiver