

## TimerBlox: Voltage-Controlled Pulse Width Modulator (PWM)

### FEATURES

- Pulse Width Modulation (PWM) Controlled by Simple 0V to 1V Analog Input
- Four Available Options Define Duty Cycle Limits
  - Minimum Duty Cycle at 0% or 5%
  - Maximum Duty Cycle at 95% or 100%
- Frequency Range: 3.81Hz to 1MHz
- Configured with 1 to 3 Resistors
- <1.7% Maximum Frequency Error
- PWM Duty Cycle Error <3.7% Maximum
- Frequency Modulation (VCO) Capability
- 2.25V to 5.5V Single Supply Operation
- 115µA Supply Current at 100kHz
- 500µs Start-Up Time
- CMOS Output Driver Sources/Sinks 20mA
- –55°C to 125°C Operating Temperature Range
- Available in Low Profile (1mm) SOT-23 (ThinSOT™) and 2mm × 3mm DFN

### APPLICATIONS

- PWM Servo Loops
- Heater Control
- LED Dimming Control
- High Vibration, High Acceleration Environments
- Portable and Battery-Powered Equipment

LT, LT, LTC and LTM, Linear Technology, TimerBlox and the Linear logo are registered trademarks and ThinSOT is a trademark of Linear Technology Corporation. All other trademarks are the property of their respective owners.

### DESCRIPTION

The LTC®6992 is a silicon oscillator with an easy-to-use analog voltage-controlled pulse width modulation (PWM) capability. The LTC6992 is part of the TimerBlox® family of versatile silicon timing devices.

A single resistor,  $R_{SET}$ , programs the LTC6992's internal master oscillator frequency. The output frequency is determined by this master oscillator and an internal frequency divider,  $N_{DIV}$ , programmable to eight settings from 1 to 16384.

$$f_{OUT} = \frac{1\text{MHz}}{N_{DIV}} \cdot \frac{50\text{k}\Omega}{R_{SET}}, N_{DIV} = 1, 4, 16 \dots 16384$$

Applying a voltage between 0V and 1V on the MOD pin sets the duty cycle.

The four versions differ in their minimum/maximum duty cycle. Note that a minimum duty cycle limit of 0% or maximum duty cycle limit of 100% allows oscillations to stop at the extreme duty cycle settings.

DEVICE NAME	PWM DUTY CYCLE RANGE
LTC6992-1	0% to 100%
LTC6992-2	5% to 95%
LTC6992-3	0% to 95%
LTC6992-4	5% to 100%

For easy configuration of the LTC6992, download the TimerBlox Designer tool at [www.linear.com/timerblox](http://www.linear.com/timerblox).

### TYPICAL APPLICATION

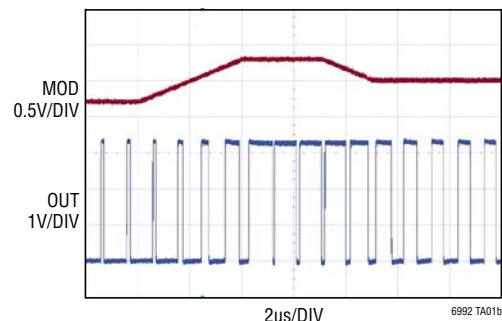
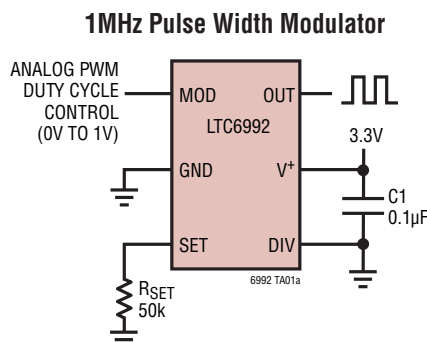

# LTC6992-1/LTC6992-2/ LTC6992-3/LTC6992-4

## ABSOLUTE MAXIMUM RATINGS (Note 1)

Supply Voltage ( $V^+$ ) to GND .....	6V
Maximum Voltage On Any Pin ..... ( $GND - 0.3V \leq V_{PIN} \leq (V^+ + 0.3V)$ )	
Operating Temperature Range (Note 2)	
LTC6992C .....	-40°C to 85°C
LTC6992I .....	-40°C to 85°C
LTC6992H .....	-40°C to 125°C
LTC6992MP .....	-55°C to 125°C

Specified Temperature Range (Note 3)	
LTC6992C .....	0°C to 70°C
LTC6992I .....	-40°C to 85°C
LTC6992H .....	-40°C to 125°C
LTC6992MP .....	-55°C to 125°C
Junction Temperature .....	150°C
Storage Temperature Range .....	-65°C to 150°C
Lead Temperature (Soldering, 10 sec) S6 Package .....	300°C

## PIN CONFIGURATION

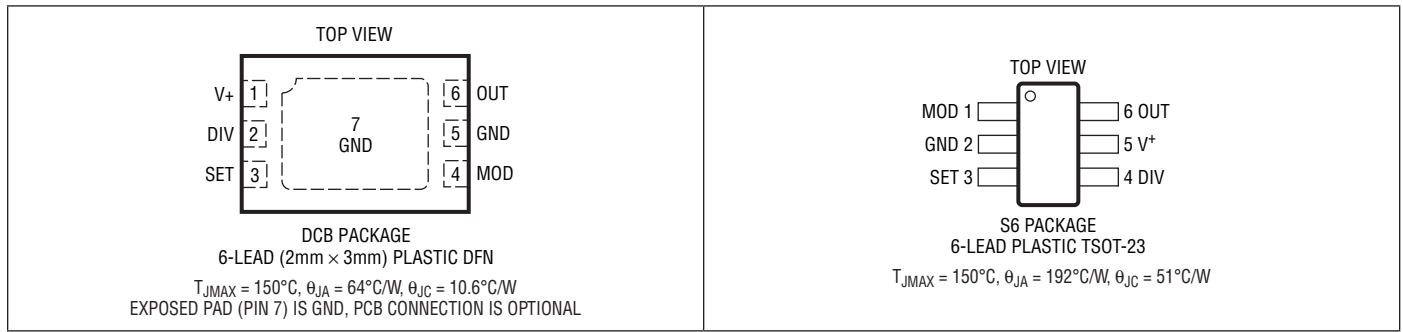

## ORDER INFORMATION

### Lead Free Finish

TAPE AND REEL (MINI)	TAPE AND REEL	PART MARKING*	PACKAGE DESCRIPTION	SPECIFIED TEMPERATURE RANGE
LTC6992CDCB-1#TRMPBF	LTC6992CDCB-1#TRPBF	LDXC	6-Lead (2mm × 3mm) Plastic DFN	0°C to 70°C
LTC6992IDCB-1#TRMPBF	LTC6992IDCB-1#TRPBF	LDXC	6-Lead (2mm × 3mm) Plastic DFN	-40°C to 85°C
LTC6992HDCB-1#TRMPBF	LTC6992HDCB-1#TRPBF	LDXC	6-Lead (2mm × 3mm) Plastic DFN	-40°C to 125°C
LTC6992CS6-1#TRMPBF	LTC6992CS6-1#TRPBF	LTDXB	6-Lead Plastic TSOT-23	0°C to 70°C
LTC6992IS6-1#TRMPBF	LTC6992IS6-1#TRPBF	LTDXB	6-Lead Plastic TSOT-23	-40°C to 85°C
LTC6992HS6-1#TRMPBF	LTC6992HS6-1#TRPBF	LTDXB	6-Lead Plastic TSOT-23	-40°C to 125°C
LTC6992CDCB-2#TRMPBF	LTC6992CDCB-2#TRPBF	LDXF	6-Lead (2mm × 3mm) Plastic DFN	0°C to 70°C
LTC6992IDCB-2#TRMPBF	LTC6992IDCB-2#TRPBF	LDXF	6-Lead (2mm × 3mm) Plastic DFN	-40°C to 85°C
LTC6992HDCB-2#TRMPBF	LTC6992HDCB-2#TRPBF	LDXF	6-Lead (2mm × 3mm) Plastic DFN	-40°C to 125°C
LTC6992CS6-2#TRMPBF	LTC6992CS6-2#TRPBF	LTDXD	6-Lead Plastic TSOT-23	0°C to 70°C
LTC6992IS6-2#TRMPBF	LTC6992IS6-2#TRPBF	LTDXD	6-Lead Plastic TSOT-23	-40°C to 85°C
LTC6992HS6-2#TRMPBF	LTC6992HS6-2#TRPBF	LTDXD	6-Lead Plastic TSOT-23	-40°C to 125°C
LTC6992CDCB-3#TRMPBF	LTC6992CDCB-3#TRPBF	LFCP	6-Lead (2mm × 3mm) Plastic DFN	0°C to 70°C
LTC6992IDCB-3#TRMPBF	LTC6992IDCB-3#TRPBF	LFCP	6-Lead (2mm × 3mm) Plastic DFN	-40°C to 85°C
LTC6992HDCB-3#TRMPBF	LTC6992HDCB-3#TRPBF	LFCP	6-Lead (2mm × 3mm) Plastic DFN	-40°C to 125°C
LTC6992CS6-3#TRMPBF	LTC6992CS6-3#TRPBF	LTFCQ	6-Lead Plastic TSOT-23	0°C to 70°C
LTC6992IS6-3#TRMPBF	LTC6992IS6-3#TRPBF	LTFCQ	6-Lead Plastic TSOT-23	-40°C to 85°C
LTC6992HS6-3#TRMPBF	LTC6992HS6-3#TRPBF	LTFCQ	6-Lead Plastic TSOT-23	-40°C to 125°C

## ORDER INFORMATION

### Lead Free Finish

TAPE AND REEL (MINI)	TAPE AND REEL	PART MARKING*	PACKAGE DESCRIPTION	SPECIFIED TEMPERATURE RANGE
LTC6992CDCB-4#TRMPBF	LTC6992CDCB-4#TRPBF	LFCR	6-Lead (2mm × 3mm) Plastic DFN	0°C to 70°C
LTC6992IDCB-4#TRMPBF	LTC6992IDCB-4#TRPBF	LFCR	6-Lead (2mm × 3mm) Plastic DFN	-40°C to 85°C
LTC6992HDCB-4#TRMPBF	LTC6992HDCB-4#TRPBF	LFCR	6-Lead (2mm × 3mm) Plastic DFN	-40°C to 125°C
LTC6992CS6-4#TRMPBF	LTC6992CS6-4#TRPBF	LTFCS	6-Lead Plastic TSOT-23	0°C to 70°C
LTC6992IS6-4#TRMPBF	LTC6992IS6-4#TRPBF	LTFCS	6-Lead Plastic TSOT-23	-40°C to 85°C
LTC6992HS6-4#TRMPBF	LTC6992HS6-4#TRPBF	LTFCS	6-Lead Plastic TSOT-23	-40°C to 125°C
LTC6992MPS6-1#TRMPBF	LTC6992MPS6-1#TRPBF	LTDXB	6-Lead Plastic TSOT-23	-55°C to 125°C
LTC6992MPS6-2#TRMPBF	LTC6992MPS6-2#TRPBF	LTDXD	6-Lead Plastic TSOT-23	-55°C to 125°C
LTC6992MPS6-3#TRMPBF	LTC6992MPS6-3#TRPBF	LTFCQ	6-Lead Plastic TSOT-23	-55°C to 125°C
LTC6992MPS6-4#TRMPBF	LTC6992MPS6-4#TRPBF	LTFCS	6-Lead Plastic TSOT-23	-55°C to 125°C

TRM = 500 pieces. \*Temperature grades are identified by a label on the shipping container.

Consult LTC Marketing for parts specified with wider operating temperature ranges.

Consult LTC Marketing for information on lead based finish parts.

For more information on lead free part marking, go to: <http://www.linear.com/leadfree/>

For more information on tape and reel specifications, go to: <http://www.linear.com/tapeandree/>

## ELECTRICAL CHARACTERISTICS

The ● denotes the specifications which apply over the full operating temperature range, otherwise specifications are at  $T_A = 25^\circ\text{C}$ . Test conditions are  $V^+ = 2.25\text{V}$  to  $5.5\text{V}$ ,  $V_{\text{MOD}} = 0\text{V}$  to  $V_{\text{SET}}$ ,  $\text{DIVCODE} = 0$  to  $15$  ( $N_{\text{DIV}} = 1$  to  $16,384$ ),  $R_{\text{SET}} = 50\text{k}$  to  $800\text{k}$ ,  $R_{\text{LOAD}} = 5\text{k}$ ,  $C_{\text{LOAD}} = 5\text{pF}$  unless otherwise noted.

SYMBOL	PARAMETER	CONDITIONS	MIN	TYP	MAX	UNITS
<b>Oscillation Frequency</b>						
$f_{\text{OUT}}$	Output Frequency		3.81		1000000	Hz
$\Delta f_{\text{OUT}}$	Frequency Accuracy (Note 4)	$3.81\text{Hz} \leq f_{\text{OUT}} \leq 1\text{MHz}$		±0.8	±1.7 ±2.4	% %
$\Delta f_{\text{OUT}}/\Delta T$	Frequency Drift Over Temperature			±0.005		%/°C
$\Delta f_{\text{OUT}}/\Delta V^+$	Frequency Drift Over Supply	$V^+ = 4.5\text{V}$ to $5.5\text{V}$ $V^+ = 2.25\text{V}$ to $4.5\text{V}$		0.25 0.08	0.65 0.18	%/V %/V
	Long-Term Frequency Stability	(Note 10)		90		ppm/√kHz
	Period Jitter (Note 9)	$N_{\text{DIV}} = 1$ $N_{\text{DIV}} = 4$ $N_{\text{DIV}} = 16$		1.2 0.4 0.07		%P-P %P-P %RMS
				0.15 0.022		%P-P %RMS
<b>Pulse Width Modulation</b>						
$\Delta D$	PWM Duty Cycle Accuracy	$V_{\text{MOD}} = 0.2 \cdot V_{\text{SET}}$ to $0.8 \cdot V_{\text{SET}}$ $V_{\text{MOD}} = 0.2 \cdot V_{\text{SET}}$ to $0.8 \cdot V_{\text{SET}}$ $V_{\text{MOD}} < 0.2 \cdot V_{\text{SET}}$ or $V_{\text{MOD}} > 0.8 \cdot V_{\text{SET}}$		±3.0	±3.7 ±4.5 ±4.9	% % %
$D_{\text{MAX}}$	Maximum Duty Cycle Limit	LTC6992-1/LTC6992-4, POL = 0, $V_{\text{MOD}} = 1\text{V}$ LTC6992-2/LTC6992-3, POL = 0, $V_{\text{MOD}} = 1\text{V}$	● ●	100 90.5	95 99	% %
$D_{\text{MIN}}$	Minimum Duty Cycle Limit	LTC6992-1/LTC6992-3, POL = 0, $V_{\text{MOD}} = 0\text{V}$ LTC6992-2/LTC6992-4, POL = 0, $V_{\text{MOD}} = 0\text{V}$	● ●	1	5 9.5	% %
$t_{\text{S,PWM}}$	Duty Cycle Settling Time (Note 6)	$t_{\text{MASTER}} = t_{\text{OUT}}/N_{\text{DIV}}$		$8 \cdot t_{\text{MASTER}}$		μS

# LTC6992-1/LTC6992-2/ LTC6992-3/LTC6992-4

**ELECTRICAL CHARACTERISTICS** The ● denotes the specifications which apply over the full operating temperature range, otherwise specifications are at  $T_A = 25^\circ\text{C}$ . Test conditions are  $V^+ = 2.25\text{V}$  to  $5.5\text{V}$ ,  $V_{\text{MOD}} = 0\text{V}$  to  $V_{\text{SET}}$ ,  $\text{DIVCODE} = 0$  to  $15$  ( $N_{\text{DIV}} = 1$  to  $16,384$ ),  $R_{\text{SET}} = 50\text{k}$  to  $800\text{k}$ ,  $R_{\text{LOAD}} = 5\text{k}$ ,  $C_{\text{LOAD}} = 5\text{pF}$  unless otherwise noted.

SYMBOL	PARAMETER	CONDITIONS	MIN	TYP	MAX	UNITS		
<b>Power Supply</b>								
$V^+$	Operating Supply Voltage Range		●	2.25	5.5	V		
	Power-On Reset Voltage		●		1.95	V		
$I_S$	Supply Current	$R_L = \infty$ , $R_{\text{SET}} = 50\text{k}$ , $N_{\text{DIV}} = 1$	$V^+ = 5.5\text{V}$	●	365	450	$\mu\text{A}$	
			$V^+ = 2.25\text{V}$	●	225	285	$\mu\text{A}$	
		$R_L = \infty$ , $R_{\text{SET}} = 50\text{k}$ , $N_{\text{DIV}} = 4$	$V^+ = 5.5\text{V}$	●	350	420	$\mu\text{A}$	
			$V^+ = 2.25\text{V}$	●	225	280	$\mu\text{A}$	
		$R_L = \infty$ , $R_{\text{SET}} = 50\text{k}$ , $N_{\text{DIV}} \geq 16$	$V^+ = 5.5\text{V}$	●	325	390	$\mu\text{A}$	
			$V^+ = 2.25\text{V}$	●	215	265	$\mu\text{A}$	
		$R_L = \infty$ , $R_{\text{SET}} = 800\text{k}$ , $N_{\text{DIV}} = 1$ to $16,384$	$V^+ = 5.5\text{V}$	●	120	170	$\mu\text{A}$	
			$V^+ = 2.25\text{V}$	●	105	150	$\mu\text{A}$	
<b>Analog Inputs</b>								
$V_{\text{SET}}$	Voltage at SET Pin		●	0.97	1.00	1.03	V	
$\Delta V_{\text{SET}}/\Delta T$	$V_{\text{SET}}$ Drift Over Temperature		●		$\pm 75$		$\mu\text{V}/^\circ\text{C}$	
$R_{\text{SET}}$	Frequency-Setting Resistor		●	50	800		$\text{k}\Omega$	
	MOD Pin Input Capacitance				2.5		$\text{pF}$	
	MOD Pin Input Current		●			$\pm 10$	$\text{nA}$	
$V_{\text{MOD,HI}}$	$V_{\text{MOD}}$ Voltage for Maximum Duty Cycle	LTC6992-1/LTC6992-4, POL = 0, D = 100%	●		$0.90 \cdot V_{\text{SET}}$	$0.936 \cdot V_{\text{SET}}$	V	
		LTC6992-2/LTC6992-3, POL = 0, D = 95%			$0.86 \cdot V_{\text{SET}}$		V	
$V_{\text{MOD,LO}}$	$V_{\text{MOD}}$ Voltage for Minimum Duty Cycle	LTC6992-1/LTC6992-3, POL = 0, D = 0%	●	$0.064 \cdot V_{\text{SET}}$	$0.10 \cdot V_{\text{SET}}$		V	
		LTC6992-2/LTC6992-4, POL = 0, D = 5%			$0.14 \cdot V_{\text{SET}}$		V	
$V_{\text{DIV}}$	DIV Pin Voltage		●	0	$V^+$		V	
$\Delta V_{\text{DIV}}/\Delta V^+$	DIV Pin Valid Code Range (Note 5)	Deviation from Ideal $V_{\text{DIV}}/V^+ = (\text{DIVCODE} + 0.5)/16$	●			$\pm 1.5$	%	
		DIV Pin Input Current	●			$\pm 10\text{nA}$		
<b>Digital Output</b>								
$I_{\text{OUT(MAX)}}$	Output Current	$V^+ = 2.7\text{V}$ to $5.5\text{V}$			$\pm 20$		$\text{mA}$	
$V_{\text{OH}}$	High Level Output Voltage (Note 7)	$V^+ = 5.5\text{V}$	$I_{\text{OUT}} = -1\text{mA}$	●	5.45	5.48	V	
			$I_{\text{OUT}} = -16\text{mA}$	●	4.84	5.15	V	
		$V^+ = 3.3\text{V}$	$I_{\text{OUT}} = -1\text{mA}$	●	3.24	3.27	V	
			$I_{\text{OUT}} = -10\text{mA}$	●	2.75	2.99	V	
$V^+ = 2.25\text{V}$	$I_{\text{OUT}} = -1\text{mA}$	●	2.17	2.21	V			
	$I_{\text{OUT}} = -8\text{mA}$	●	1.58	1.88	V			
$V_{\text{OL}}$	Low Level Output Voltage (Note 7)	$V^+ = 5.5\text{V}$	$I_{\text{OUT}} = 1\text{mA}$	●		0.02	0.04	V
			$I_{\text{OUT}} = 16\text{mA}$	●		0.26	0.54	V
		$V^+ = 3.3\text{V}$	$I_{\text{OUT}} = 1\text{mA}$	●		0.03	0.05	V
			$I_{\text{OUT}} = 10\text{mA}$	●		0.22	0.46	V
		$V^+ = 2.25\text{V}$	$I_{\text{OUT}} = 1\text{mA}$	●		0.03	0.07	V
			$I_{\text{OUT}} = 8\text{mA}$	●		0.26	0.54	V
$t_r$	Output Rise Time (Note 8)	$V^+ = 5.5\text{V}$ , $R_{\text{LOAD}} = \infty$			1.1		ns	
		$V^+ = 3.3\text{V}$ , $R_{\text{LOAD}} = \infty$			1.7		ns	
		$V^+ = 2.25\text{V}$ , $R_{\text{LOAD}} = \infty$			2.7		ns	
$t_f$	Output Fall Time (Note 8)	$V^+ = 5.5\text{V}$ , $R_{\text{LOAD}} = \infty$			1.0		ns	
		$V^+ = 3.3\text{V}$ , $R_{\text{LOAD}} = \infty$			1.6		ns	
		$V^+ = 2.25\text{V}$ , $R_{\text{LOAD}} = \infty$			2.4		ns	

69921234fc

## ELECTRICAL CHARACTERISTICS

**Note 1:** Stresses beyond those listed under Absolute Maximum Ratings may cause permanent damage to the device. Exposure to any Absolute Maximum Rating condition for extended periods may affect device reliability and lifetime.

**Note 2:** The LTC6992C is guaranteed functional over the operating temperature range of  $-40^{\circ}\text{C}$  to  $85^{\circ}\text{C}$ .

**Note 3:** The LTC6992C is guaranteed to meet specified performance from  $0^{\circ}\text{C}$  to  $70^{\circ}\text{C}$ . The LTC6992C is designed, characterized and expected to meet specified performance from  $-40^{\circ}\text{C}$  to  $85^{\circ}\text{C}$  but it is not tested or QA sampled at these temperatures. The LTC6992I is guaranteed to meet specified performance from  $-40^{\circ}\text{C}$  to  $85^{\circ}\text{C}$ . The LTC6992H is guaranteed to meet specified performance from  $-40^{\circ}\text{C}$  to  $125^{\circ}\text{C}$ . The LTC6992MP is guaranteed to meet specified performance from  $-55^{\circ}\text{C}$  to  $125^{\circ}\text{C}$ .

**Note 4:** Frequency accuracy is defined as the deviation from the  $f_{\text{OUT}}$  equation, assuming  $R_{\text{SET}}$  is used to program the frequency.

**Note 5:** See Operation section, Table 1 and Figure 2 for a full explanation of how the DIV pin voltage selects the value of DIVCODE.

**Note 6:** Duty cycle settling time is the amount of time required for the output to settle within  $\pm 1\%$  of the final duty cycle after a  $\pm 10\%$  change in the setting ( $\pm 80\text{mV}$  step in  $V_{\text{MOD}}$ ).

**Note 7:** To conform to the Logic IC Standard, current out of a pin is arbitrarily given a negative value.

**Note 8:** Output rise and fall times are measured between the 10% and the 90% power supply levels with 5pF output load. These specifications are based on characterization.

**Note 9:** Jitter is the ratio of the peak-to-peak deviation of the period to the mean of the period. This specification is based on characterization and is not 100% tested.

**Note 10:** Long-term drift of silicon oscillators is primarily due to the movement of ions and impurities within the silicon and is tested at  $30^{\circ}\text{C}$  under otherwise nominal operating conditions. Long-term drift is specified as  $\text{ppm}/\sqrt{\text{kHr}}$  due to the typically nonlinear nature of the drift. To calculate drift for a set time period, translate that time into thousands of hours, take the square root and multiply by the typical drift number. For instance, a year is 8.77kHr and would yield a drift of 266ppm at  $90\text{ppm}/\sqrt{\text{kHr}}$ . Drift without power applied to the device may be approximated as 1/10th of the drift with power, or  $9\text{ppm}/\sqrt{\text{kHr}}$  for a  $90\text{ppm}/\sqrt{\text{kHr}}$  device.

## TYPICAL PERFORMANCE CHARACTERISTICS

$V^+ = 3.3\text{V}$ ,  $R_{\text{SET}} = 200\text{k}$ , and  $T_A = 25^{\circ}\text{C}$ , unless otherwise noted.

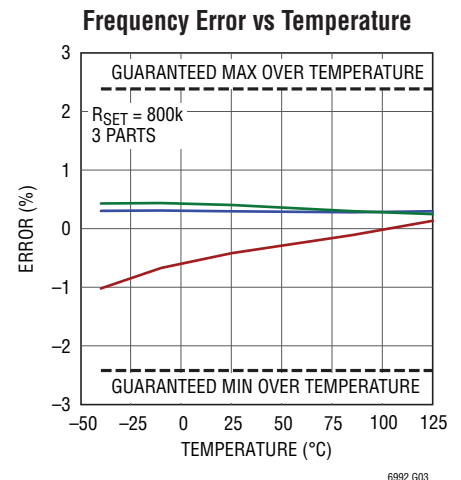
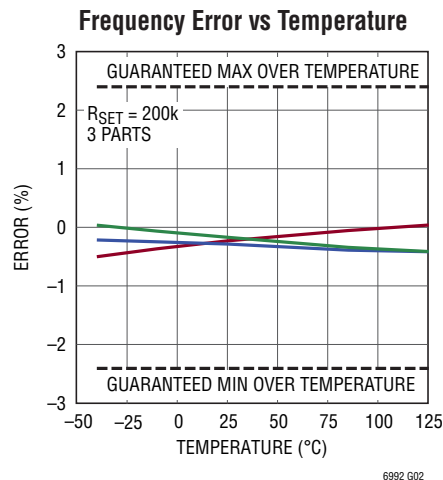
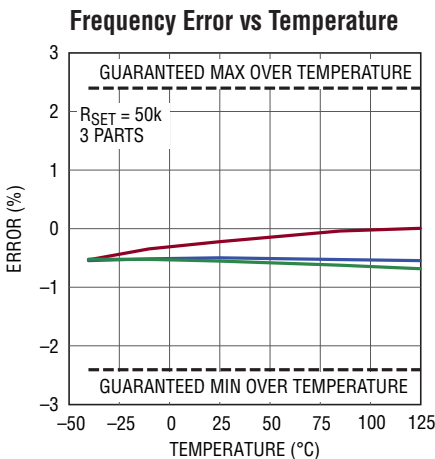

# LTC6992-1/LTC6992-2/ LTC6992-3/LTC6992-4

## TYPICAL PERFORMANCE CHARACTERISTICS

$V^+ = 3.3V$ ,  $R_{SET} = 200k$ , and  $T_A = 25^\circ C$ , unless otherwise noted.

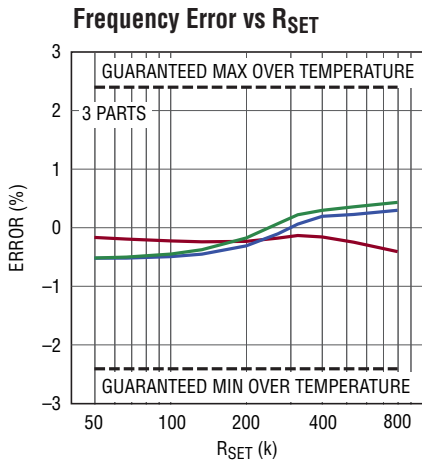

6992 G04

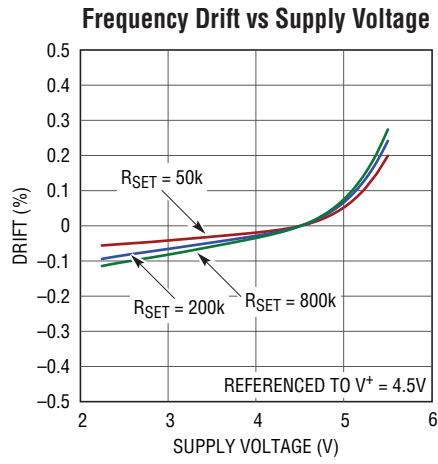

6992 G05

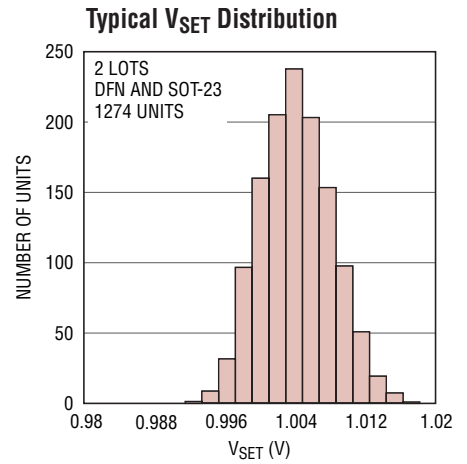

6992 G06

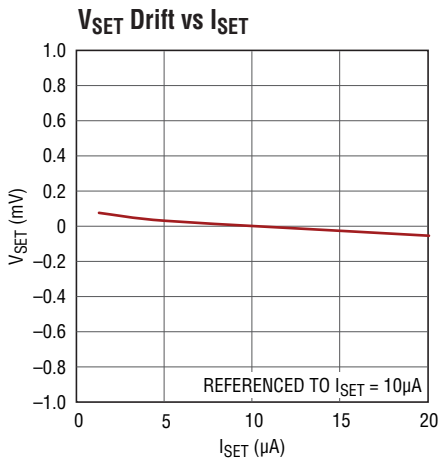

6992 G07

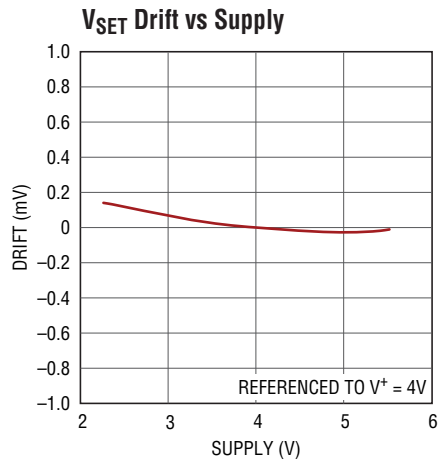

6992 G08

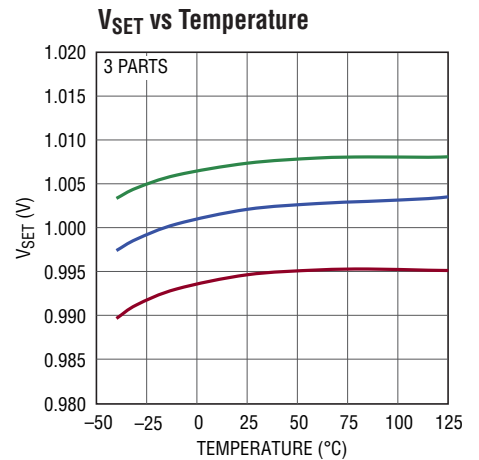

6992 G09

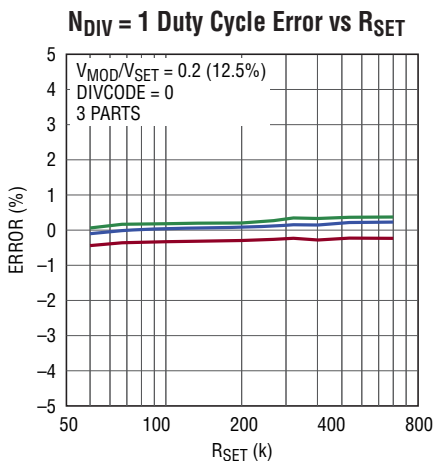

6992 G10

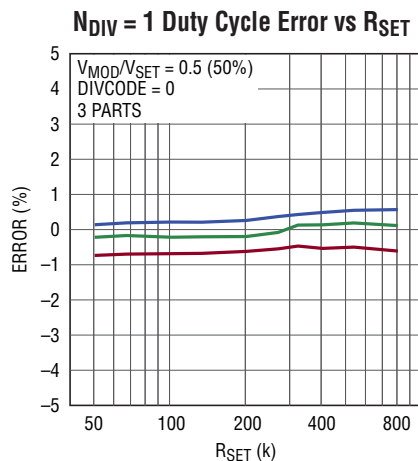

6992 G11

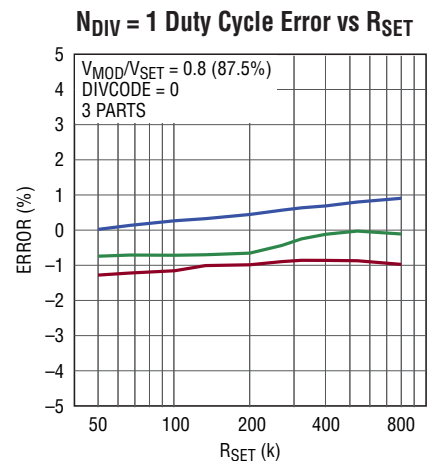

6992 G12

69921234fc

**TYPICAL PERFORMANCE CHARACTERISTICS**  $V^+ = 3.3V$ ,  $R_{SET} = 200k$ , and  $T_A = 25^\circ C$ , unless otherwise noted.

$V^+ = 3.3V$ ,  $R_{SET} = 200k$ , and  $T_A = 25^\circ C$ , unless otherwise noted.

**$N_{DIV} > 1$  Duty Cycle Error vs  $R_{SET}$**

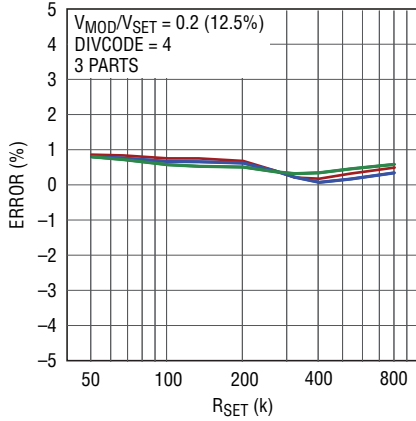

6992 G13

**$N_{DIV} > 1$  Duty Cycle Error vs  $R_{SET}$**

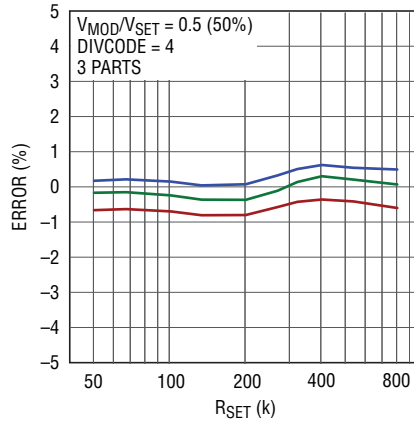

6992 G14

**$N_{DIV} > 1$  Duty Cycle Error vs  $R_{SET}$**

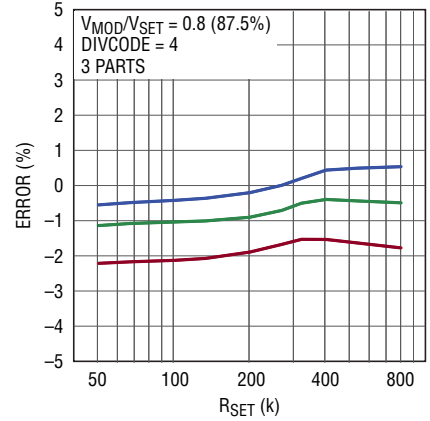

6992 G15

**$N_{DIV} = 1$  Duty Cycle Clamps vs  $R_{SET}$**

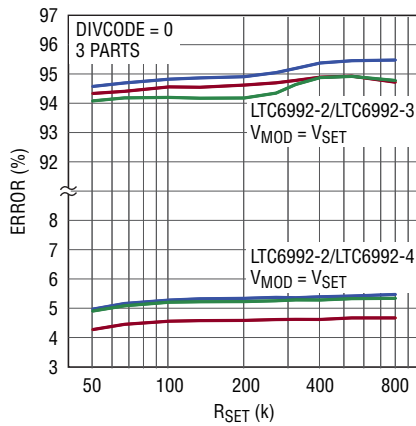

6992 G16

**$N_{DIV} > 1$  Duty Cycle Error vs  $R_{SET}$**

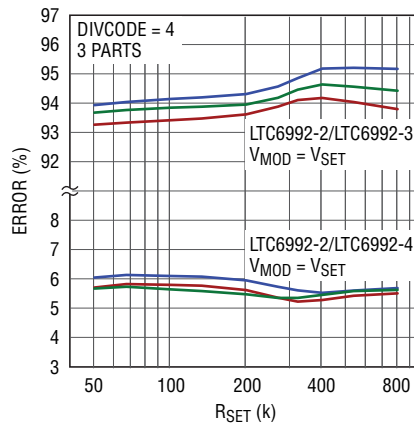

6992 G17

**$N_{DIV} = 1$  Duty Cycle Error vs Temperature**

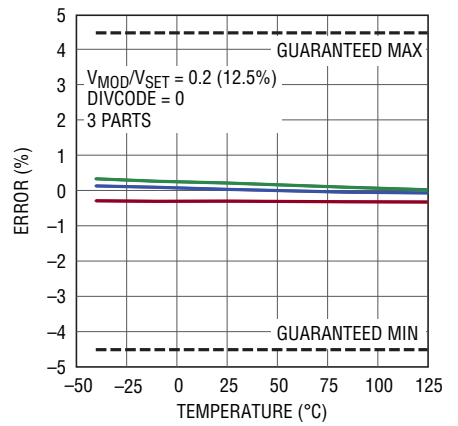

6992 G18

**$N_{DIV} = 1$  Duty Cycle Error vs Temperature**

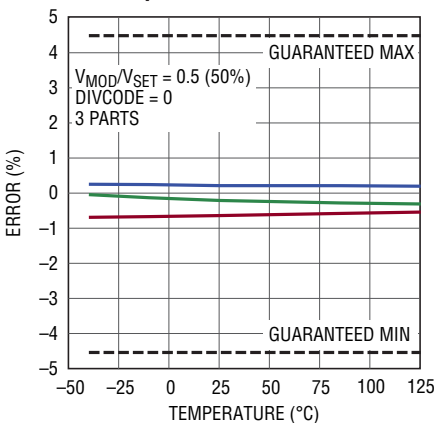

6992 G19

**$N_{DIV} = 1$  Duty Cycle Error vs Temperature**

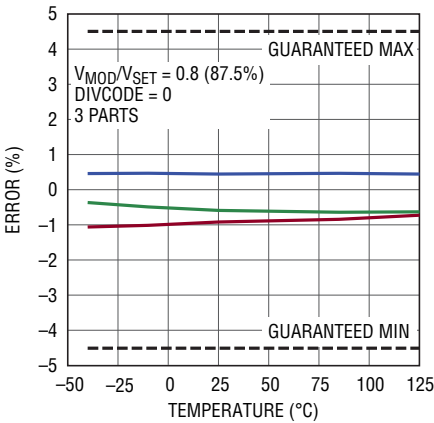

6992 G20

**$N_{DIV} > 1$  Duty Cycle Error vs Temperature**

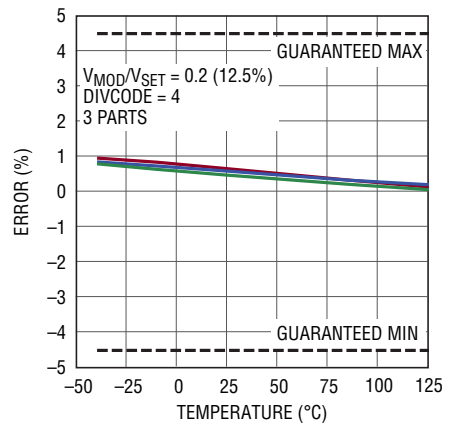

6992 G21

# LTC6992-1/LTC6992-2/ LTC6992-3/LTC6992-4

## TYPICAL PERFORMANCE CHARACTERISTICS

$V^+ = 3.3V$ ,  $R_{SET} = 200k$ , and  $T_A = 25^\circ C$ , unless otherwise noted.

**$N_{DIV} > 1$  Duty Cycle Error vs Temperature**

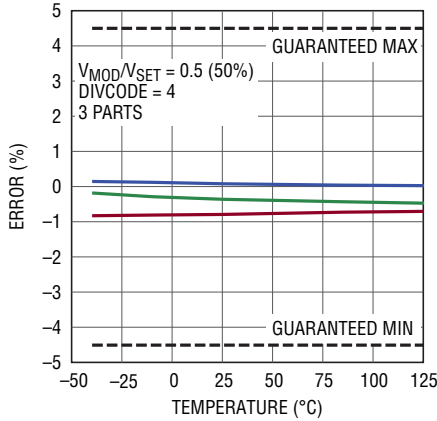

**$N_{DIV} > 1$  Duty Cycle Error vs Temperature**

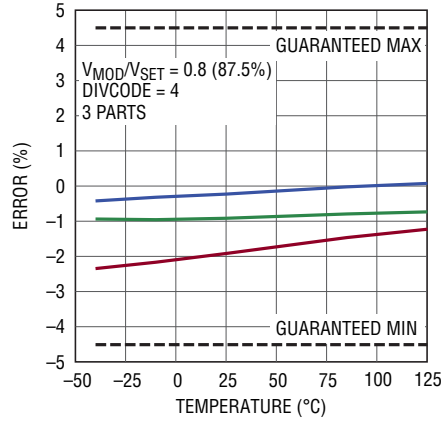

**$N_{DIV} = 1$  Duty Cycle Clamps vs Temperature**

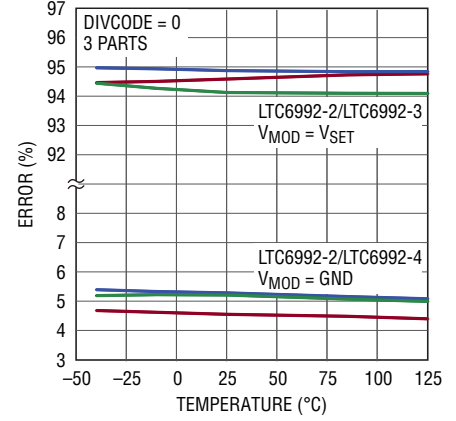

**$N_{DIV} > 1$  Duty Cycle Clamps vs Temperature**

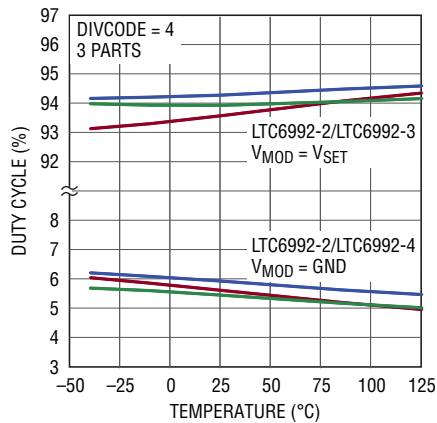

**Duty Cycle Error vs DIVCODE**

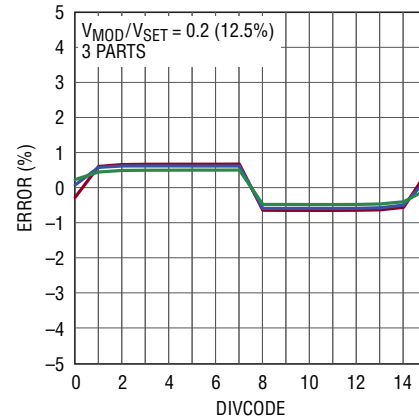

**Duty Cycle Error vs DIVCODE**

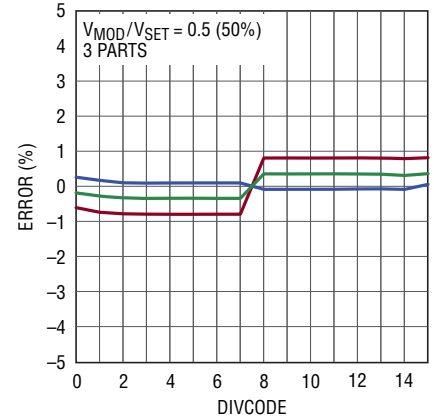

**Duty Cycle Error vs DIVCODE**

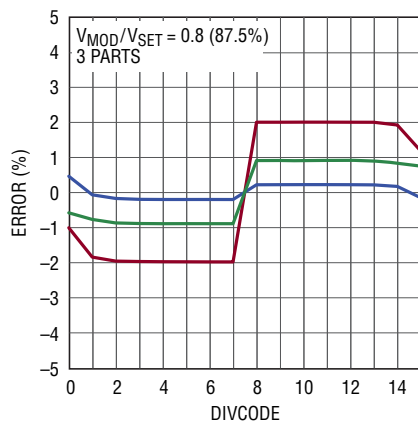

**$N_{DIV} = 1$  Duty Cycle vs  $V_{MOD}/V_{SET}$**

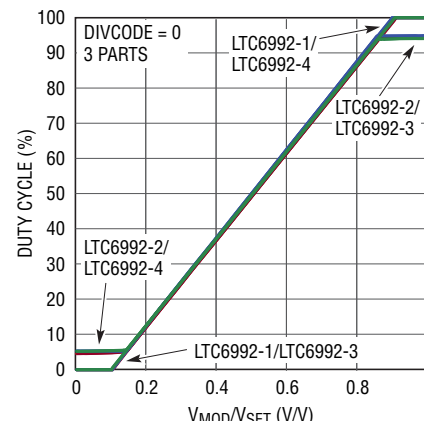

**$N_{DIV} > 1$  Duty Cycle vs  $V_{MOD}/V_{SET}$**

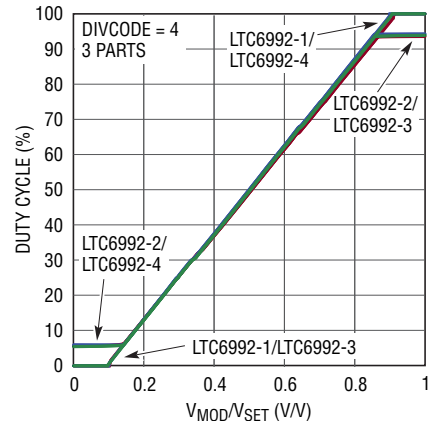

**TYPICAL PERFORMANCE CHARACTERISTICS**

$V^+ = 3.3V$ ,  $R_{SET} = 200k$ , and  $T_A = 25^\circ C$ , unless otherwise noted.

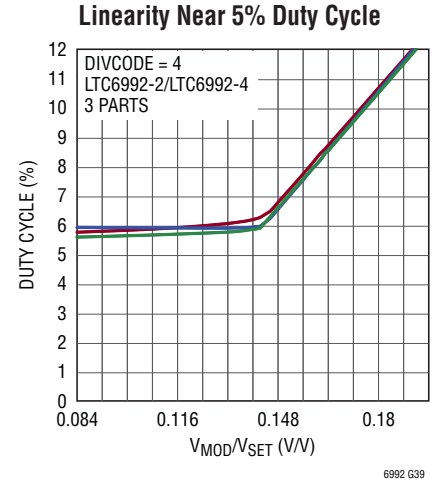
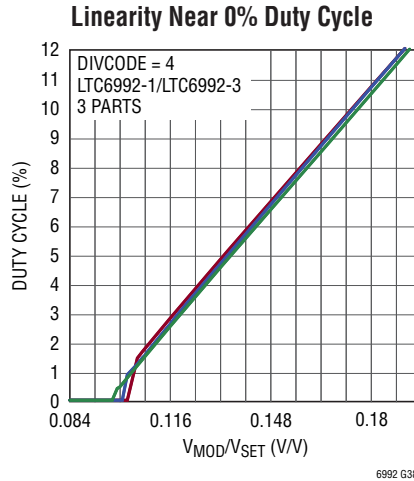
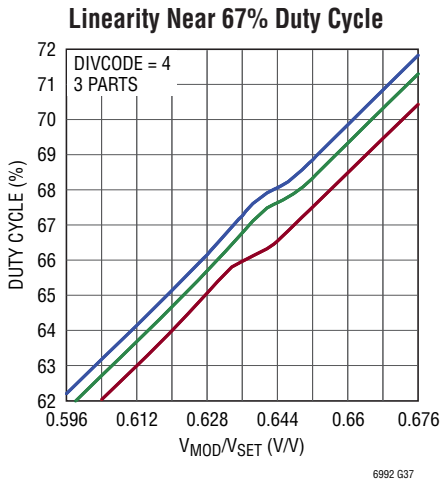
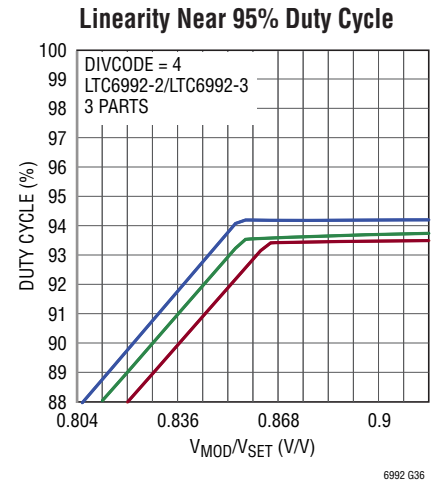
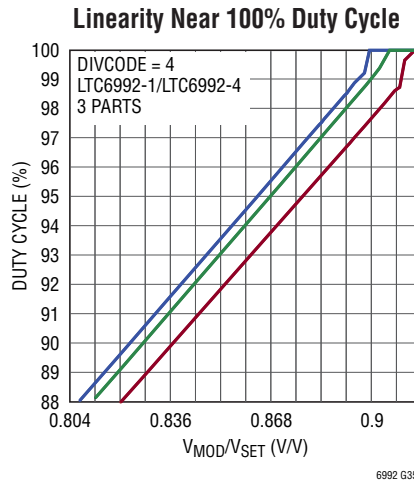
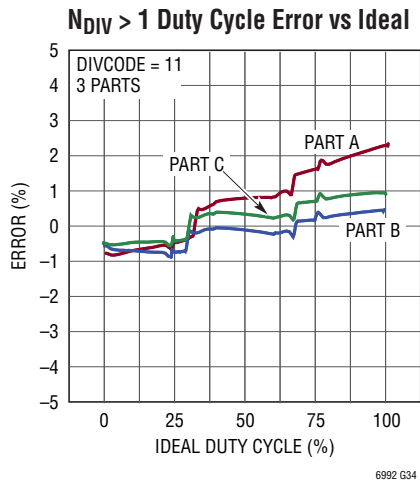
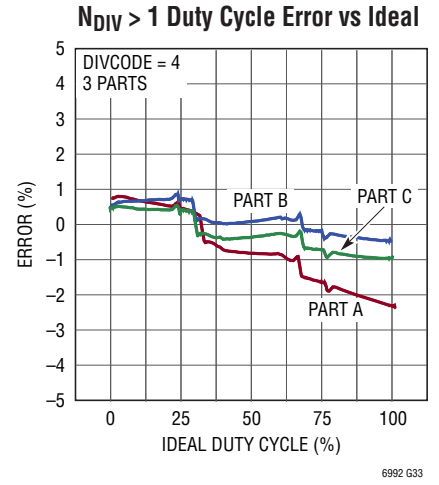
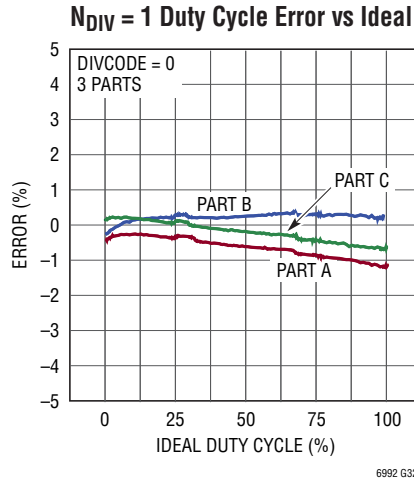
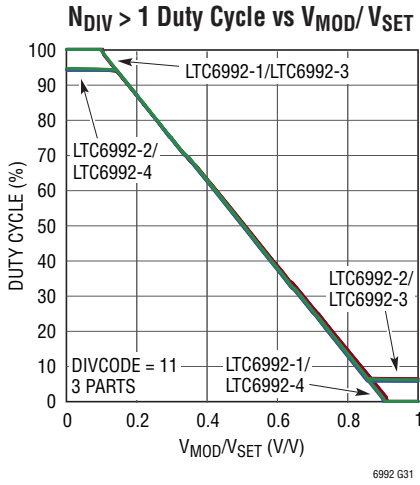

# LTC6992-1/LTC6992-2/ LTC6992-3/LTC6992-4

## TYPICAL PERFORMANCE CHARACTERISTICS

$V^+ = 3.3V$ ,  $R_{SET} = 200k$ , and  $T_A = 25^\circ C$ , unless otherwise noted.

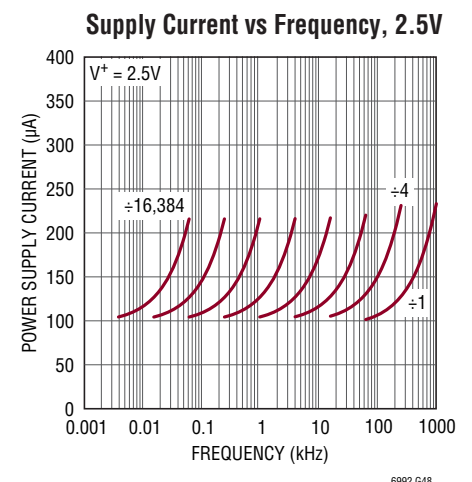
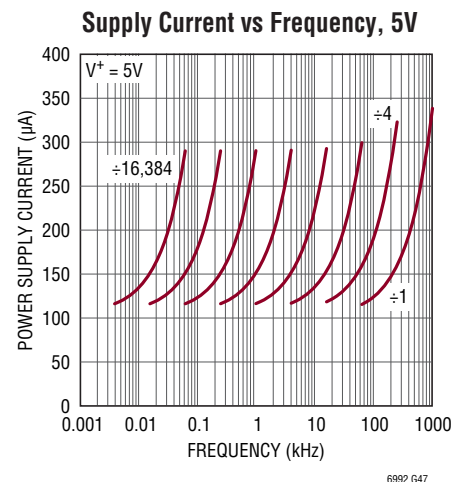
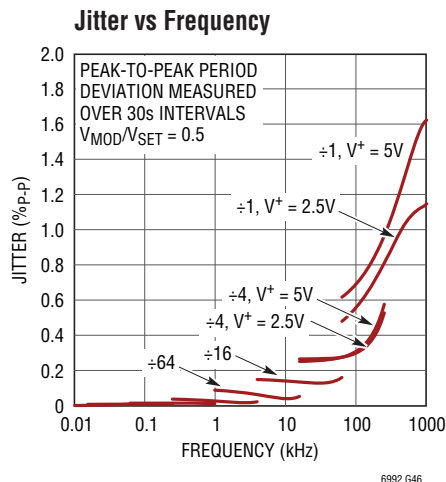
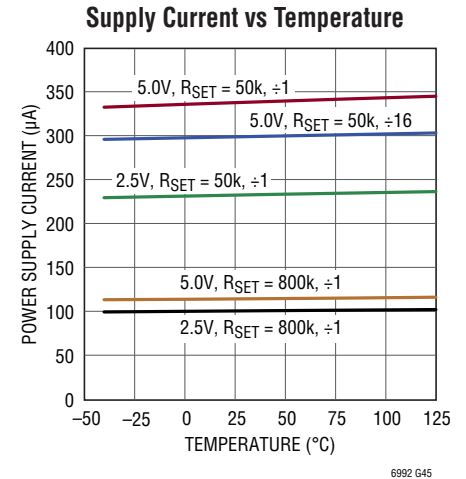
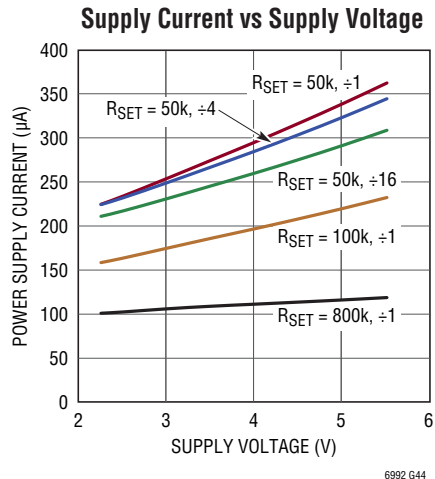
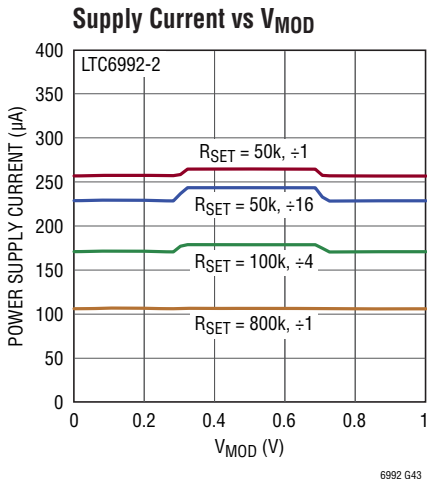
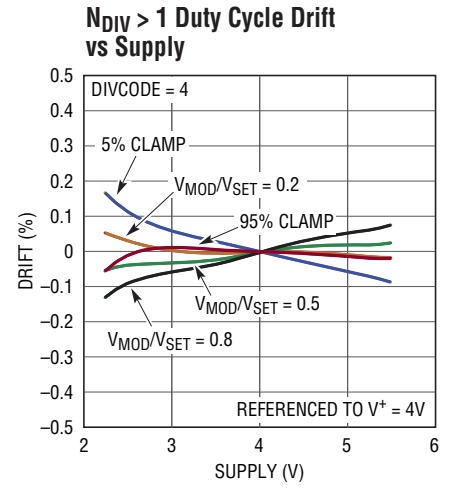
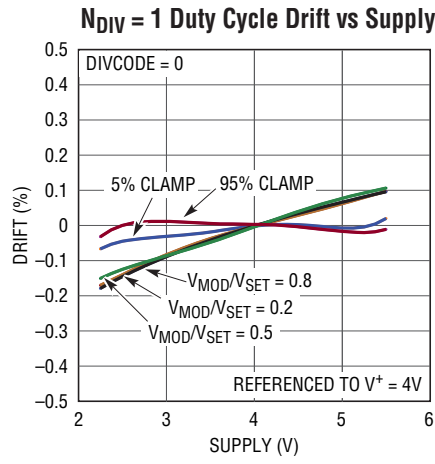
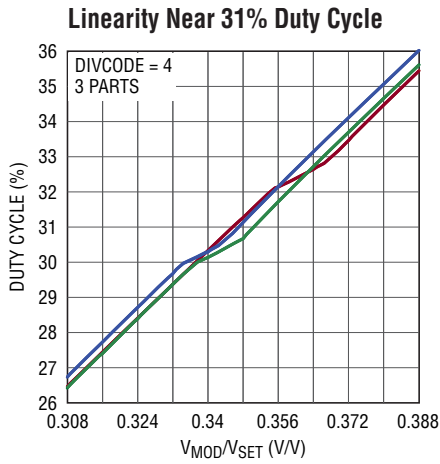

69921234fc

**TYPICAL PERFORMANCE CHARACTERISTICS**  $V^+ = 3.3V$ ,  $R_{SET} = 200k$ , and  $T_A = 25^\circ C$ , unless otherwise noted.

**Typical Frequency Error vs Time (Long-Term Drift)**

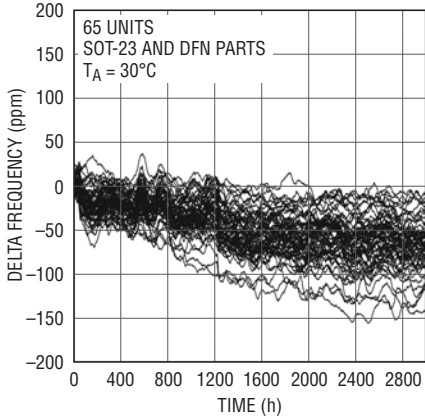

6992 G48a

**Output Resistance vs Supply Voltage**

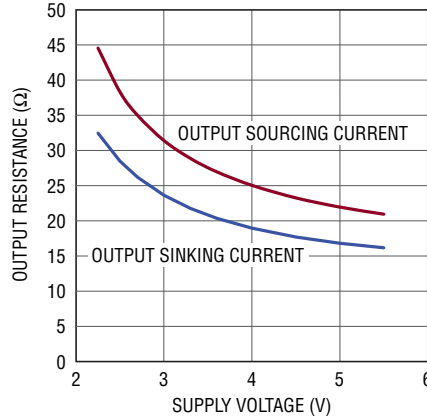

6992 G50

**Rise and Fall Time vs Supply Voltage**

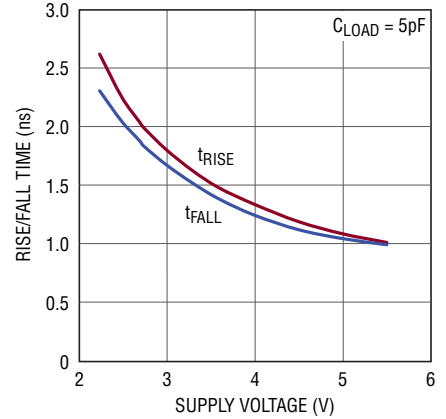

6992 G51

**Typical  $I_{SET}$  Current Limit vs  $V^+$**

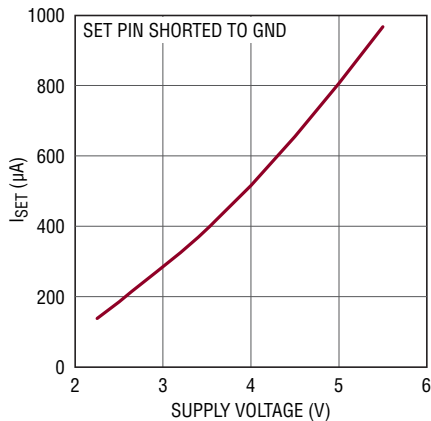

6992 G52

**Typical Start-Up, POL = 0**

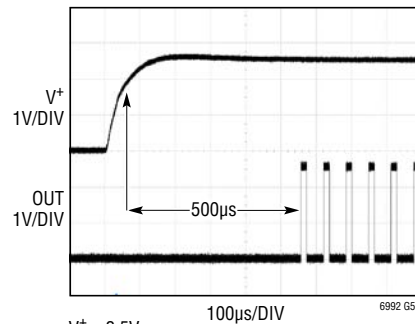

6992 G53

$V^+ = 2.5V$   
DIVCODE = 3 ( $\pm 64$ )  
 $R_{SET} = 50k$   
 $V_{MOD} = 0.3V$  (~25% DUTY CYCLE)

**Typical Start-Up, POL = 1**

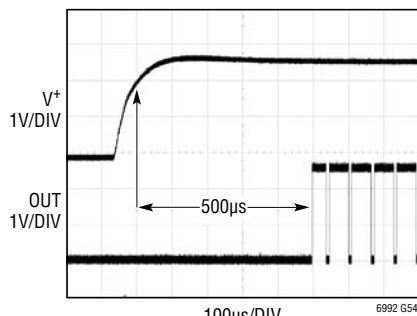

6992 G54

$V^+ = 2.5V$   
DIVCODE = 12 ( $\pm 64$ , POL = 1)  
 $R_{SET} = 50k$   
 $V_{MOD} = 0.2V$  (~87.5% DUTY CYCLE)

**125kHz Full Modulation**

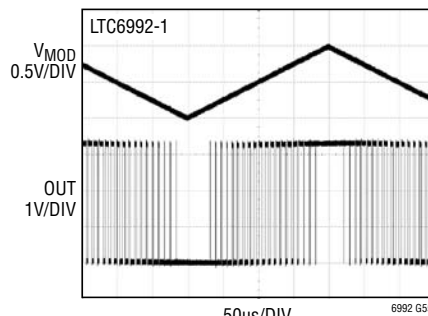

6992 G55

LTC6992-1  
 $V^+ = 3.3V$   
DIVCODE = 1  
 $R_{SET} = 100k$

## PIN FUNCTIONS (DCB/S6)

**V<sup>+</sup> (Pin 1/Pin 5):** Supply Voltage (2.25V to 5.5V). This supply should be kept free from noise and ripple. It should be bypassed directly to the GND pin with a 0.1μF capacitor.

**DIV (Pin 2/Pin 4):** Programmable Divider and Polarity Input. The DIV pin voltage ( $V_{DIV}$ ) is internally converted into a 4-bit result (DIVCODE).  $V_{DIV}$  may be generated by a resistor divider between V<sup>+</sup> and GND. Use 1% resistors to ensure an accurate result. The DIV pin and resistors should be shielded from the OUT pin or any other traces that have fast edges. Limit the capacitance on the DIV pin to less than 100pF so that  $V_{DIV}$  settles quickly. The MSB of DIVCODE (POL) determines if the PWM signal is inverted before driving the output. When POL = 1 the transfer function is inverted (duty cycle decreasing as  $V_{MOD}$  increases).

**SET (Pin 3/Pin 3):** Frequency-Setting Input. The voltage on the SET pin ( $V_{SET}$ ) is regulated to 1V above GND. The amount of current sourced from the SET pin ( $I_{SET}$ ) programs the master oscillator frequency. The  $I_{SET}$  current range is 1.25μA to 20μA. The output oscillation will stop if  $I_{SET}$  drops below approximately 500nA. A resistor connected between SET and GND is the most accurate way to set the frequency. For best performance, use a precision metal or thin film resistor of 0.5% or better tolerance and 50ppm/°C or better temperature coefficient. For lower accuracy applications an inexpensive 1% thick film resistor may be used.

Limit the capacitance on the SET pin to less than 10pF to minimize jitter and ensure stability. Capacitance less than 100pF maintains the stability of the feedback circuit regulating the  $V_{SET}$  voltage.

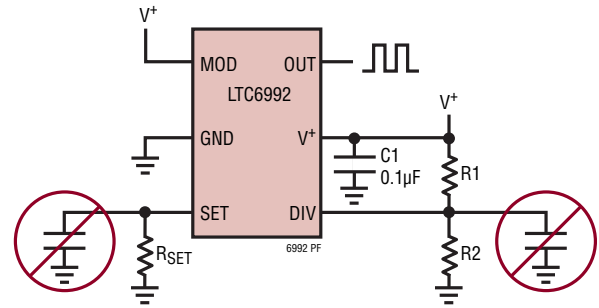

**MOD (Pin 4/Pin 1):** Pulse-Width Modulation Input. The voltage on the MOD pin controls the output duty cycle. The linear control range is between  $0.1 \cdot V_{SET}$  and  $0.9 \cdot V_{SET}$  (approximately 100mV to 900mV). Beyond those limits, the output will either clamp at 5% or 95%, or stop oscillating (0% or 100% duty cycle), depending on the version.

**GND (Pin 5/Pin 2):** Ground. Tie to a low inductance ground plane for best performance.

**OUT (Pin 6/Pin 6):** Oscillator Output. The OUT pin swings from GND to V<sup>+</sup> with an output resistance of approximately 30Ω. The duty cycle is determined by the voltage on the MOD pin. When driving an LED or other low-impedance load a series output resistor should be used to limit the source/sink current to 20mA.

**BLOCK DIAGRAM** (S6 Package Pin Numbers Shown)

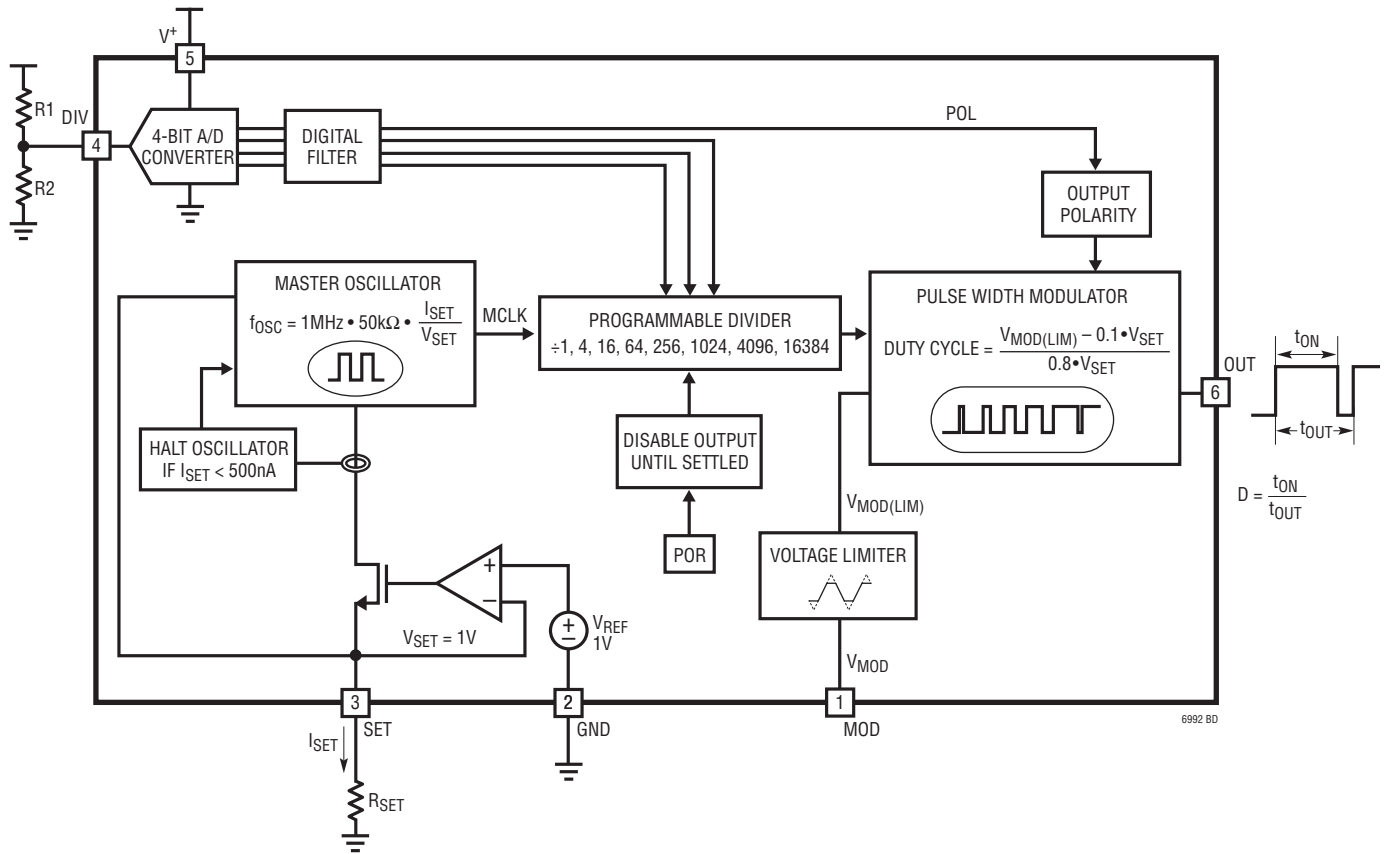

6992 BD

## OPERATION

The LTC6992 is built around a master oscillator with a 1MHz maximum frequency. The oscillator is controlled by the SET pin current ( $I_{SET}$ ) and voltage ( $V_{SET}$ ), with a  $1\text{MHz} \cdot 50\text{k}$  conversion factor that is accurate to  $\pm 0.8\%$  under typical conditions.

$$f_{MASTER} = \frac{1}{t_{MASTER}} = 1\text{MHz} \cdot 50\text{k} \cdot \frac{I_{SET}}{V_{SET}}$$

A feedback loop maintains  $V_{SET}$  at  $1\text{V} \pm 30\text{mV}$ , leaving  $I_{SET}$  as the primary means of controlling the output frequency. The simplest way to generate  $I_{SET}$  is to connect a resistor ( $R_{SET}$ ) between SET and GND, such that  $I_{SET} = V_{SET}/R_{SET}$ . The master oscillator equation reduces to:

$$f_{MASTER} = \frac{1}{t_{MASTER}} = \frac{1\text{MHz} \cdot 50\text{k}}{R_{SET}}$$

From this equation, it is clear that  $V_{SET}$  drift will not affect the output frequency when using a single program resistor ( $R_{SET}$ ). Error sources are limited to  $R_{SET}$  tolerance and the inherent frequency accuracy  $\Delta f_{OUT}$  of the LTC6992.

$R_{SET}$  may range from 50k to 800k (equivalent to  $I_{SET}$  between  $1.25\mu\text{A}$  and  $20\mu\text{A}$ ).

The LTC6992 includes a programmable frequency divider which can further divide the frequency by 1, 4, 16, 64, 256, 1024, 4096 or 16384 before driving the OUT pin. The divider ratio  $N_{DIV}$  is set by a resistor divider attached to the DIV pin.

$$f_{OUT} = \frac{1}{t_{OUT}} = \frac{1\text{MHz} \cdot 50\text{k}}{N_{DIV}} \cdot \frac{I_{SET}}{V_{SET}}$$

With  $R_{SET}$  in place of  $V_{SET}/I_{SET}$  the equation reduces to:

$$f_{OUT} = \frac{1}{t_{OUT}} = \frac{1\text{MHz} \cdot 50\text{k}}{N_{DIV} \cdot R_{SET}}$$

## DIVCODE

The DIV pin connects to an internal,  $V^+$  referenced 4-bit A/D converter that determines the DIVCODE value. DIVCODE programs two settings on the LTC6992:

1. DIVCODE determines the output frequency divider setting,  $N_{DIV}$ .
2. DIVCODE determines the output polarity, via the POL bit.

$V_{DIV}$  may be generated by a resistor divider between  $V^+$  and GND as shown in Figure 1.

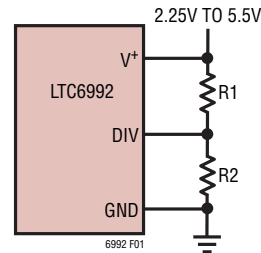

Figure 1. Simple Technique for Setting DIVCODE

## OPERATION

Table 1. DIVCODE Programming

DIVCODE	POL	N <sub>DIV</sub>	RECOMMENDED f <sub>OUT</sub>	R1 (kΩ)	R2 (kΩ)	V <sub>DIV</sub> /V <sup>+</sup>
0	0	1	62.5kHz to 1MHz	Open	Short	≤0.03125 ±0.015
1	0	4	15.63kHz to 250kHz	976	102	0.09375 ±0.015
2	0	16	3.906kHz to 62.5kHz	976	182	0.15625 ±0.015
3	0	64	976.6Hz to 15.63kHz	1000	280	0.21875 ±0.015
4	0	256	244.1Hz to 3.906kHz	1000	392	0.28125 ±0.015
5	0	1024	61.04Hz to 976.6Hz	1000	523	0.34375 ±0.015
6	0	4096	15.26Hz to 244.1Hz	1000	681	0.40625 ±0.015
7	0	16384	3.815Hz to 61.04Hz	1000	887	0.46875 ±0.015
8	1	16384	3.815Hz to 61.04Hz	887	1000	0.53125 ±0.015
9	1	4096	15.26Hz to 244.1Hz	681	1000	0.59375 ±0.015
10	1	1024	61.04Hz to 976.6Hz	523	1000	0.65625 ±0.015
11	1	256	244.1Hz to 3.906kHz	392	1000	0.71875 ±0.015
12	1	64	976.6Hz to 15.63kHz	280	1000	0.78125 ±0.015
13	1	16	3.906kHz to 62.5kHz	182	976	0.84375 ±0.015
14	1	4	15.63kHz to 250kHz	102	976	0.90625 ±0.015
15	1	1	62.5kHz to 1MHz	Short	Open	≥0.96875 ±0.015

Table 1 offers recommended 1% resistor values that accurately produce the correct voltage division as well as the corresponding N<sub>DIV</sub> and POL values for the recommended resistor pairs. Other values may be used as long as:

1. The V<sub>DIV</sub>/V<sup>+</sup> ratio is accurate to ±1.5% (including resistor tolerances and temperature effects).
2. The driving impedance (R1||R2) does not exceed 500kΩ.

If the voltage is generated by other means (i.e. the output of a DAC) it must track the V<sup>+</sup> supply voltage. The last

column in Table 1 shows the ideal ratio of V<sub>DIV</sub> to the supply voltage, which can also be calculated as:

$$\frac{V_{DIV}}{V^+} = \frac{DIVCODE + 0.5}{16} \pm 1.5\%$$

For example, if the supply is 3.3V and the desired DIVCODE is 4, V<sub>DIV</sub> = 0.281 • 3.3V = 928mV ± 50mV.

Figure 2 illustrates the information in Table 1, showing that N<sub>DIV</sub> is symmetric around the DIVCODE midpoint.

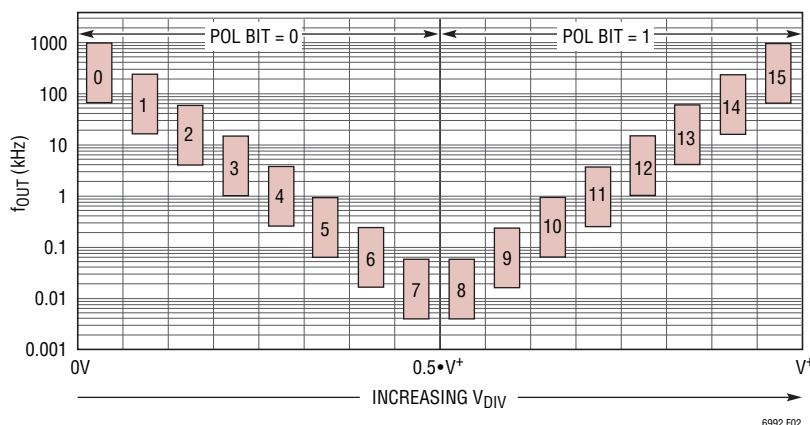

Figure 2. Frequency Range and POL Bit vs DIVCODE

6992 F02

## OPERATION

### Pulse Width (Duty Cycle) Modulation

The MOD pin is a high impedance analog input providing direct control of the output duty cycle. The duty cycle is proportional to the voltage applied to the MOD pin,  $V_{MOD}$ .

$$\text{Duty Cycle} = D = \frac{V_{MOD}}{0.8 \cdot V_{SET}} - \frac{1}{8}$$

The PWM duty cycle accuracy  $\Delta D$  specifies that the above equation is valid to within  $\pm 4.5\%$  for  $V_{MOD}$  between  $0.2 \cdot V_{SET}$  and  $0.8 \cdot V_{SET}$  (12.5% to 87.5% duty cycle).

Since  $V_{SET} = 1V \pm 30mV$ , the duty cycle equation may be approximated by the following equation.

$$\text{Duty Cycle} = D \cong \frac{V_{MOD} - 100mV}{800mV}$$

The  $V_{MOD}$  control range is approximately 0.1V to 0.9V. Driving  $V_{MOD}$  beyond that range (towards GND or  $V^+$ ) will have no further effect on the duty cycle.

### Duty Cycle Limits

The only difference between the four versions of the LTC6992 is the limits, or clamps, placed on the output duty cycle. The LTC6992-1 generates output duty cycles ranging from 0% to 100%. At 0% or 100% the output will stop oscillating and rest at GND or  $V^+$ , respectively.

The LTC6992-2 will never stop oscillating, regardless of the  $V_{MOD}$  level. Internal clamping circuits limit its duty cycle to a 5% to 95% range (1% to 99% guaranteed). Therefore, its  $V_{MOD}$  control range is  $0.14 \cdot V_{SET}$  to  $0.86 \cdot V_{SET}$  (approximately 0.14V to 0.86V).

The LTC6992-3 and LTC6992-4 complete the family by providing one-sided clamping. The LTC6992-3 allows 0% to 95% duty cycle, and the LTC6992-4 allows 5% to 100% duty cycle.

### Output Polarity (POL Bit)

The duty cycle equation describes a proportional transfer function, where duty cycle increases as  $V_{MOD}$  increases. The LTC6992 includes a POL bit (determined by the DIVCODE as described earlier) that inverts the output signal. This makes the duty cycle gain negative, reducing duty cycle as  $V_{MOD}$  increases.

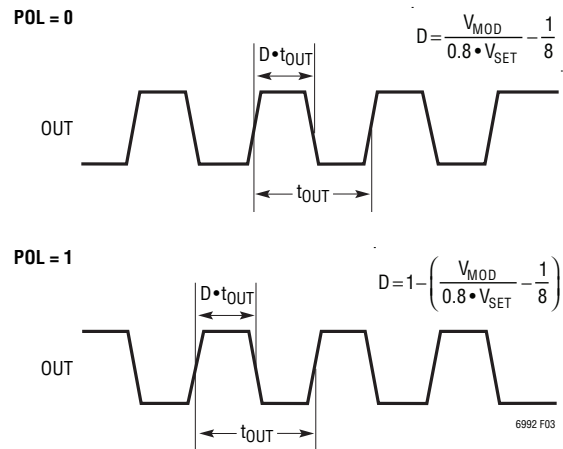

Figure 3. POL Bit Functionality

## OPERATION

POL = 1 forces a simple logic inversion, so it changes the duty cycle range of the LTC6992-3 (making it 100% to 5%) and LTC6992-4 (making it 95% to 0%). These transfer functions are detailed in Figure 4.

**Table 2. Duty Cycle Ranges**

PART NUMBER	DUTY CYCLE RANGE vs $V_{MOD} = 0V \rightarrow 1V$	
	POL = 0	POL = 1
LTC6992-1	0% to 100%	100% to 0%
LTC6992-2	5% to 95%	95% to 5%
LTC6992-3	0% to 95%	100% to 5%
LTC6992-4	5% to 100%	95% to 0%

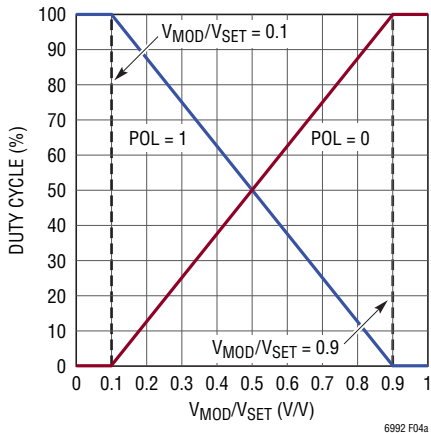

**LTC6992-1**

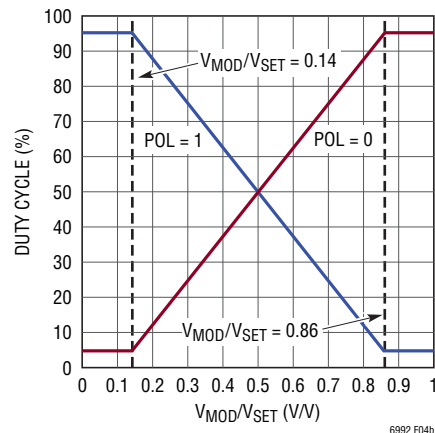

**LTC6992-2**

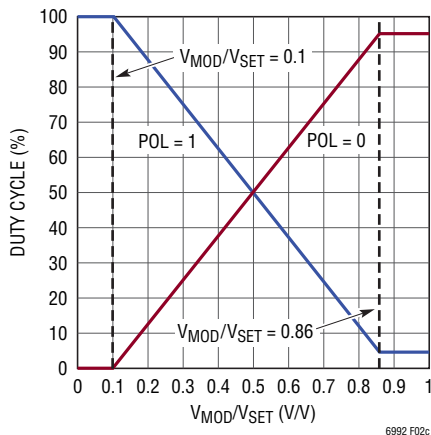

**LTC6992-3**

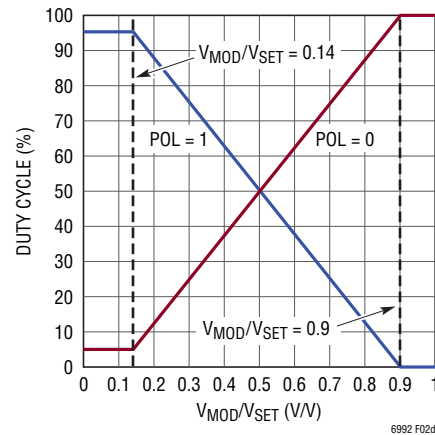

**LTC6992-4**

**Figure 4. PWM Transfer Functions for All LTC6992 Family Parts**

## OPERATION

### Changing DIVCODE After Start-Up

Following start-up, the A/D converter will continue monitoring  $V_{DIV}$  for changes. Changes to DIVCODE will be recognized slowly, as the LTC6992 places a priority on eliminating any “wandering” in the DIVCODE. The typical delay depends on the difference between the old and new DIVCODE settings and is proportional to the master oscillator period.

$$t_{DIVCODE} = 16 \cdot (\Delta DIVCODE + 6) \cdot t_{MASTER}$$

A change in DIVCODE will not be recognized until it is stable, and will not pass through intermediate codes. A digital filter is used to guarantee the DIVCODE has settled to a new value before making changes to the output. Then the output will make a clean (glitchless) transition to the new divider setting.

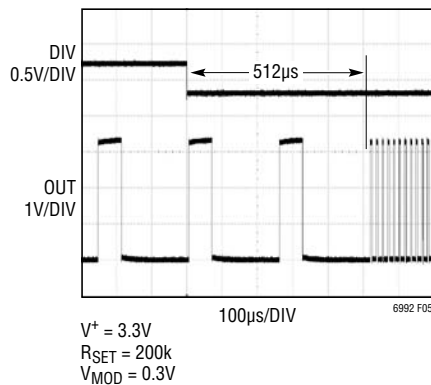

Figure 5. DIVCODE Change from 3 to 1

### Start-Up Time

When power is first applied, the power-on reset (POR) circuit will initiate the start-up time,  $t_{START}$ . The OUT pin is held low during this time. The typical value for  $t_{START}$  ranges from 0.5ms to 8ms depending on the master oscillator frequency (independent of  $N_{DIV}$ ):

$$t_{START(TYP)} = 500 \cdot t_{MASTER}$$

The output will begin oscillating after  $t_{START}$ . If  $POL = 0$  the first pulse has the correct width. If  $POL = 1$  ( $DIVCODE \geq 8$ ), the first pulse width can be shorter or longer than expected, depending on the duty cycle setting, and will never be less than 25% of  $t_{OUT}$ .

During start-up, the DIV pin A/D converter must determine the correct DIVCODE before the output is enabled. The start-up time may increase if the supply or DIV pin voltages are not stable. For this reason, it is recommended to minimize the capacitance on the DIV pin so it will properly track  $V^+$ . Less than 100pF will not affect performance.

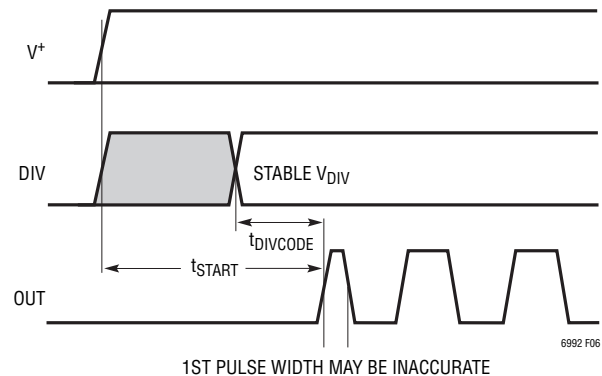

Figure 6. Start-Up Timing Diagram

## APPLICATIONS INFORMATION

### Basic Operation

The simplest and most accurate method to program the LTC6992 is to use a single resistor,  $R_{SET}$ , between the SET and GND pins. The design procedure is a four step process. After choosing the proper LTC6992 version and POL bit setting, select the  $N_{DIV}$  value and then calculate the value for the  $R_{SET}$  resistor.

Alternatively, Linear Technology offers the easy to use TimerBlox Designer tool to quickly design any LTC6992 based circuit. Download the free TimerBlox Designer software at [www.linear.com/timerblox](http://www.linear.com/timerblox).

### Step 1: Selecting the POL Bit Setting

Most applications will use  $POL = 0$ , resulting in a positive transfer function. However, some applications may require a negative transfer function, where increasing  $V_{MOD}$  reduces the output duty cycle. For example, if the LTC6992 is used in a feedback loop,  $POL = 1$  may be required to achieve negative feedback.

### Step 2: Selecting the LTC6992 Version

The difference between the LTC6992 versions is observed at the endpoints of the duty cycle control range. Applications that require the output to never stop oscillating should use the LTC6992-2. On the other hand, if the output should be allowed to rest at GND or  $V^+$  (0% or 100% duty cycle), select the LTC6992-1.

The LTC6992-3 and LTC6992-4 clamp the duty cycle at only one end of the control range, allowing the output to stop oscillating at the other extreme. If  $POL = 1$  the clamp will swap from low duty cycle to high, or vice-versa. Refer to Table 2 and Figure 4 for assistance in selecting the proper version.

### Step 3: Selecting the $N_{DIV}$ Frequency Divider Value

As explained earlier, the voltage on the DIV pin sets the DIVCODE which determines both the POL bit and the  $N_{DIV}$  value. For a given output frequency,  $N_{DIV}$  should be selected to be within the following range.

$$\frac{62.5\text{kHz}}{f_{OUT}} \leq N_{DIV} \leq \frac{1\text{MHz}}{f_{OUT}} \quad (1a)$$

To minimize supply current, choose the lowest  $N_{DIV}$  value (generally recommended). For faster start-up or decreased jitter, choose a higher  $N_{DIV}$  setting. Alternatively, use Table 1 as a guide to select the best  $N_{DIV}$  value for the given application.

With POL already chosen, this completes the selection of DIVCODE. Use Table 1 to select the proper resistor divider or  $V_{DIV}/V^+$  ratio to apply to the DIV pin.

### Step 4: Calculate and Select $R_{SET}$

The final step is to calculate the correct value for  $R_{SET}$  using the following equation.

$$R_{SET} = \frac{1\text{MHz} \cdot 50\text{k}}{N_{DIV} \cdot f_{OUT}} \quad (1b)$$

Select the standard resistor value closest to the calculated value.

*Example:* Design a PWM circuit that satisfies the following requirements:

- $f_{OUT} = 20\text{kHz}$
- Positive  $V_{MOD}$  to duty cycle response
- Output can reach 100% duty cycle, but not 0%
- Minimum power consumption

### Step 1: Selecting the POL Bit Setting

For positive transfer function (duty cycle increases with  $V_{MOD}$ ), choose  $POL = 0$ .

### Step 2: Selecting the LTC6992 Version

To limit the minimum duty cycle, but allow the maximum duty cycle to reach 100%, choose LTC6992-4. (Note that if  $POL = 1$  the LTC6992-3 would be the correct choice.)

### Step 3: Selecting the $N_{DIV}$ Frequency Divider Value

Choose an  $N_{DIV}$  value that meets the requirements of Equation (1a).

$$3.125 \leq N_{DIV} \leq 50$$

Potential settings for  $N_{DIV}$  include 4 and 16.  $N_{DIV} = 4$  is the best choice, as it minimizes supply current by us-

## APPLICATIONS INFORMATION

ing a large  $R_{SET}$  resistor.  $POL = 0$  and  $N_{DIV} = 4$  requires  $DIVCODE = 1$ . Using Table 1, choose the  $R1$  and  $R2$  values to program  $DIVCODE = 1$ .

### Step 4: Select $R_{SET}$

Calculate the correct value for  $R_{SET}$  using Equation (1b).

$$R_{SET} = \frac{1\text{MHz} \cdot 50\text{k}}{4 \cdot 20\text{kHz}} = 625\text{k}$$

Since 625k is not available as a standard 1% resistor, substitute 619k if a 0.97% frequency shift is acceptable. Otherwise, select a parallel or series pair of resistors such as 309k and 316k to attain a more precise resistance.

The completed design is shown in Figure 7.

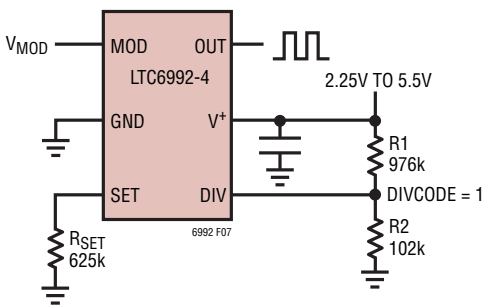

Figure 7. 20kHz PWM Oscillator

### Duty Cycle Sensitivity to $\Delta V_{SET}$

The output duty cycle is proportional to the ratio of  $V_{MOD}/V_{SET}$ . Since  $V_{SET}$  can vary up to  $\pm 30\text{mV}$  from 1V it can effectively gain or attenuate  $V_{MOD}$ , as shown below when  $\Delta V_{SET}$  is added to the equation.

$$D = \frac{V_{MOD}}{0.8 \cdot (V_{SET} + \Delta V_{SET})} - \frac{1}{8}$$

For many designs, the absolute  $V_{MOD}$  to duty cycle accuracy is not critical. For others, making the simplifying assumption of  $\Delta V_{SET} = 0\text{V}$  creates the potential for additional duty cycle error, which increases with  $V_{MOD}$ , reaching a maximum of 3.4% if  $\Delta V_{SET} = -30\text{mV}$ .

$$\Delta D \cong -\frac{V_{MOD}}{800\text{mV}} \cdot \frac{\Delta V_{SET}}{V_{SET}} \cong -\left(D_{IDEAL} + \frac{1}{8}\right) \cdot \frac{\Delta V_{SET}}{V_{SET}}$$

Figure 8 demonstrates the worst-case impact of this variation (if  $V_{SET}$  is at its 0.97V or 1.03V limits).

This error is in addition to the inherent PWM duty cycle accuracy spec  $\Delta D$  ( $\pm 4.5\%$ ), so care should be taken if accuracy at high duty cycles ( $V_{MOD}$  near 0.9V) is critical.

Sensitivity to  $\Delta V_{SET}$  can be eliminated by making  $V_{MOD}$  proportional to  $V_{SET}$ . For example, Figure 9 shows a simple circuit for generating an arbitrary duty cycle. The equation for duty cycle does not depend on  $V_{SET}$  at all.

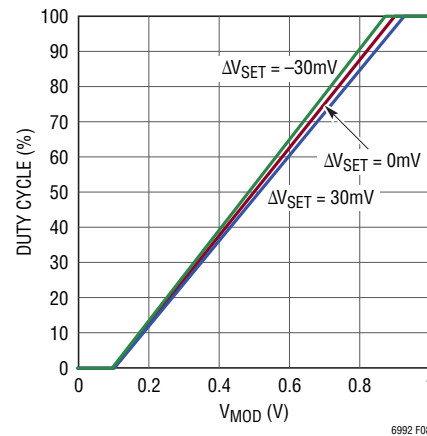

Figure 8. Duty Cycle Variation Due to  $\Delta V_{SET}$

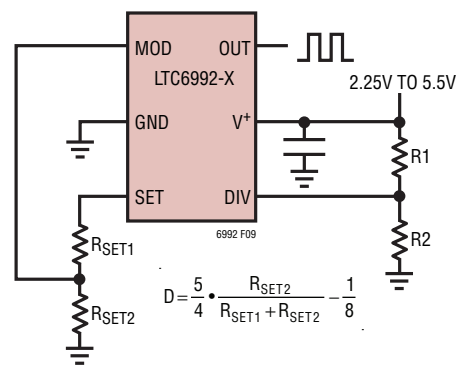

Figure 9. Fixed-Frequency, Arbitrary Duty Cycle Oscillator

## APPLICATIONS INFORMATION

### $I_{SET}$ Extremes (Master Oscillator Frequency Extremes)

When operating with  $I_{SET}$  outside of the recommended  $1.25\mu\text{A}$  to  $20\mu\text{A}$  range, the master oscillator operates outside of the  $62.5\text{kHz}$  to  $1\text{MHz}$  range in which it is most accurate.

The oscillator will still function with reduced accuracy for  $I_{SET} < 1.25\mu\text{A}$ . At approximately  $500\text{nA}$ , the oscillator output will be frozen in its current state. The output could halt in a high or low state. This avoids introducing short pulses while frequency modulating a very low frequency output.

At the other extreme, it is not recommended to operate the master oscillator beyond  $2\text{MHz}$  because the accuracy of the DIV pin ADC will suffer.

### Pulse Width Modulation Bandwidth and Settling Time

The LTC6992 has a wide PWM bandwidth, making it suitable for a variety of feedback applications. Figure 10 shows that the frequency response is flat for modulation frequencies up to nearly 1/10 of the output frequency. Beyond that point, some peaking may occur (depending on  $N_{DIV}$  and average duty cycle setting).

Duty cycle settling time depends on the master oscillator frequency. Following a  $\pm 80\text{mV}$  step change in  $V_{MOD}$ , the duty cycle takes approximately eight master clock cycles ( $8 \cdot t_{MASTER}$ ) to settle to within 1% of the final value. Examples are shown in Figures 11a and 11b.

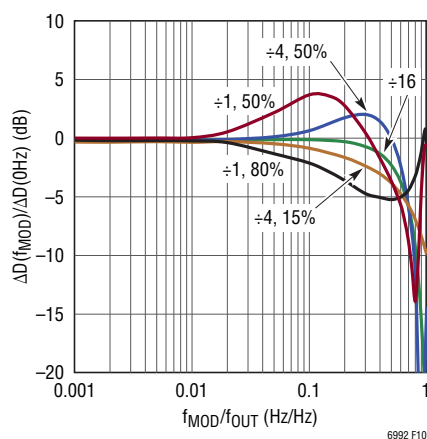

Figure 10. PWM Frequency Response

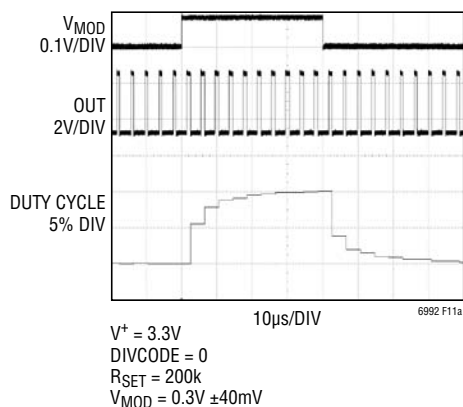

Figure 11a. PWM Settling Time, 25% Duty Cycle

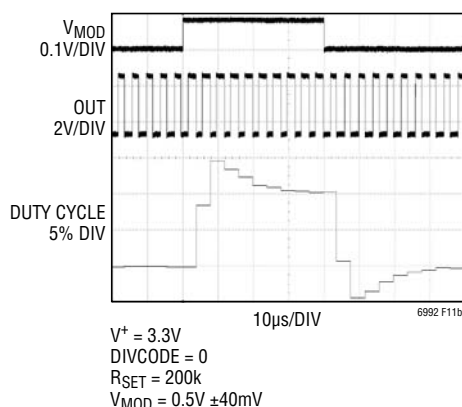

Figure 11b. PWM Settling Time, 50% Duty Cycle

## APPLICATIONS INFORMATION

### Power Supply Current

The power supply current varies with frequency, supply voltage and output loading. It can be estimated under any condition using the following equation:

If  $N_{DIV} = 1$  (DIVCODE = 0 or 15):

$$I_{S(TYP)} \approx V^+ \cdot f_{OUT} \cdot (39\text{pF} + C_{LOAD}) \\ \dots + \frac{V^+}{320\text{k}\Omega} + \frac{V^+ \cdot \text{Duty Cycle}}{R_{LOAD}} + 2.2 \cdot I_{SET} + 85\mu\text{A}$$

If  $N_{DIV} > 1$  (DIVCODE = 1 or 14):

$$I_{S(TYP)} \approx V^+ \cdot N_{DIV} \cdot f_{OUT} \cdot 27\text{pF} \\ \dots + V^+ \cdot f_{OUT} \cdot (28\text{pF} + C_{LOAD}) \\ \dots + \frac{V^+}{320\text{k}\Omega} + \frac{V^+ \cdot \text{Duty Cycle}}{R_{LOAD}} + 2.6 \cdot I_{SET} + 90\mu\text{A}$$

### SUPPLY BYPASSING AND PCB LAYOUT GUIDELINES

The LTC6992 is a 2.4% accurate silicon oscillator when used in the appropriate manner. The part is simple to use and by following a few rules, the expected performance is easily achieved. Adequate supply bypassing and proper PCB layout are important to ensure this.

Figure 14 shows example PCB layouts for both the TSOT-23 and DFN packages using 0603 sized passive components. The layouts assume a two layer board with a ground plane layer beneath and around the LTC6992. These layouts are a guide and need not be followed exactly.

1. Connect the bypass capacitor, C1, directly to the V<sup>+</sup> and GND pins using a low inductance path. The connection from C1 to the V<sup>+</sup> pin is easily done directly on the top layer. For the DFN package, C1's connection to GND is also simply done on the top layer. For the TSOT-23, OUT can be routed through the C1 pads to allow a good C1 GND connection. If the PCB design rules do not allow that, C1's GND connection can be accomplished through multiple vias to the ground plane. Multiple vias for both the GND pin connection to the ground plane and the C1 connection to the ground plane are recommended to minimize the inductance. Capacitor C1 should be a 0.1μF ceramic capacitor.
2. Place all passive components on the top side of the board. This minimizes trace inductance.
3. Place R<sub>SET</sub> as close as possible to the SET pin and make a direct, short connection. The SET pin is a current summing node and currents injected into this pin directly modulate the operating frequency. Having a short connection minimizes the exposure to signal pickup.
4. Connect R<sub>SET</sub> directly to the GND pin. Using a long path or vias to the ground plane will not have a significant affect on accuracy, but a direct, short connection is recommended and easy to apply.
5. Use a ground trace to shield the SET pin. This provides another layer of protection from radiated signals.
6. Place R1 and R2 close to the DIV pin. A direct, short connection to the DIV pin minimizes the external signal coupling.

## APPLICATIONS INFORMATION

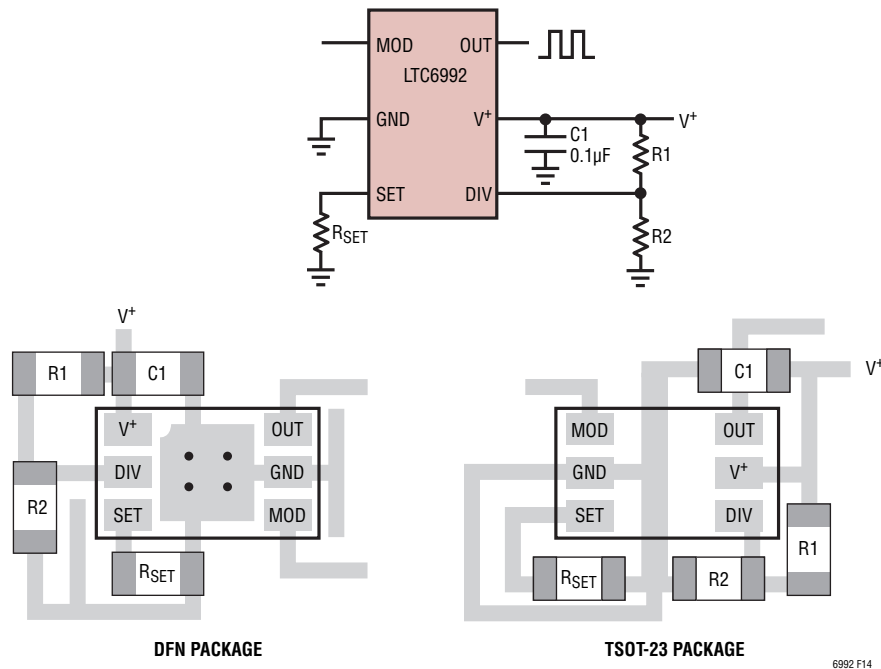
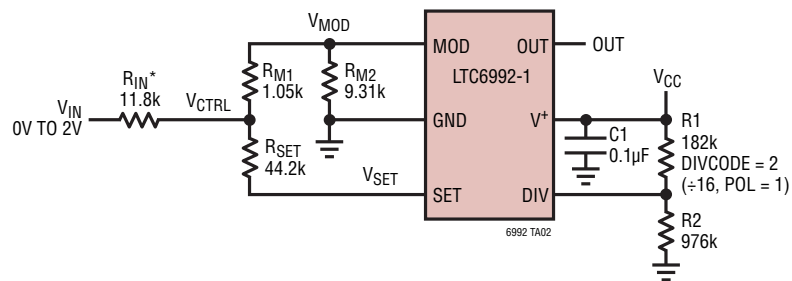

Figure 14. Supply Bypassing and PCB Layout

## TYPICAL APPLICATIONS

### Constant On-Time Modulator



\*OPTIONAL RESISTOR ADJUSTS FOR DESIRED  $V_{IN}$  RANGE.

$$\text{IF } \frac{R_{M2}}{R_{M1} + R_{M2}} = 0.9 \text{ THEN } t_{ON} = N_{DIV} \cdot 1.125\mu\text{s} \cdot \frac{R_{SET}}{50k}$$

AS  $V_{IN}$  INCREASES,  $t_{OUT}$  INCREASES AND DUTY CYCLE DECREASES (BECAUSE  $POL = 1$ ) TO MAINTAIN A CONSTANT  $t_{ON}$ . FOR CONSTANT OFF-TIME, JUST CHANGE  $DIVCODE$  SO  $POL = 0$ .

## TYPICAL APPLICATIONS

### Digitally Controlled Duty Cycle with Internal $V_{REF}$ Reference Variation Eliminated

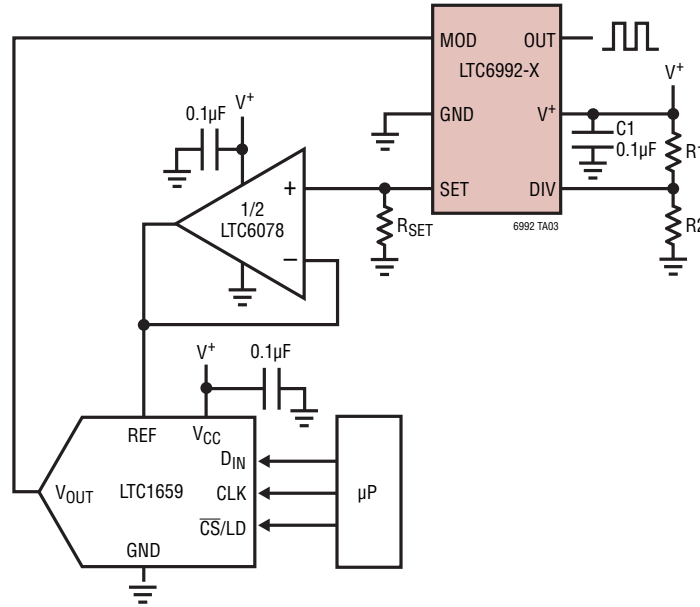

### Programming $N_{DIV}$ Using an 8-Bit DAC

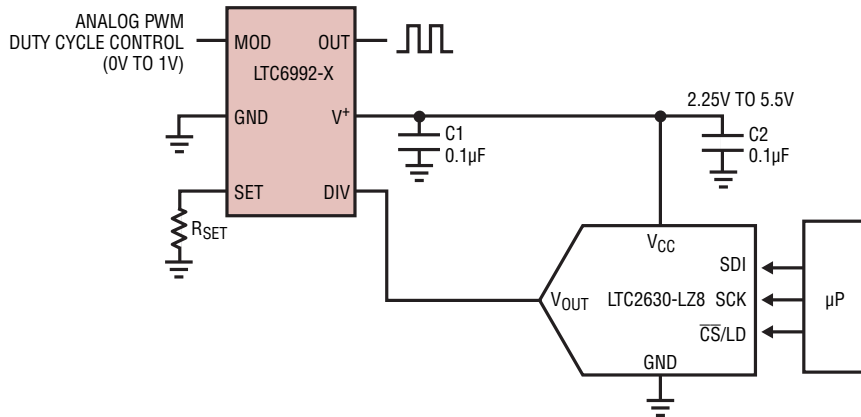

DIVCODE	DAC CODE
0	0
1	24
2	40
3	56
4	72
5	88
6	104
7	120
8	136
9	152
10	168
11	184
12	200
13	216
14	232
15	255

6992 TA04

## TYPICAL APPLICATIONS

### Changing Between Two Frequencies

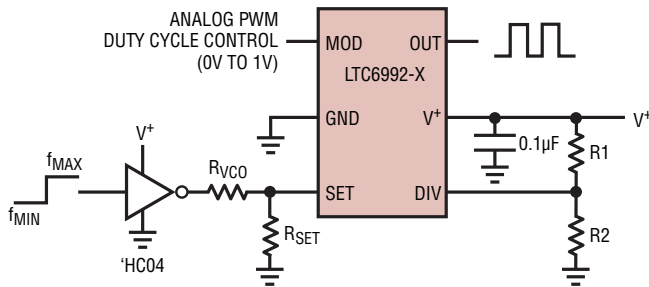

NOTES  
WHILE THIS CIRCUIT IS SIMPLER THAN THE CIRCUIT TO THE RIGHT, ITS FREQUENCY ACCURACY IS WORSE DUE TO THE EFFECT OF  $V^+$  SUPPLY VARIATION FROM SYSTEM TO SYSTEM AND OVER TEMPERATURE.

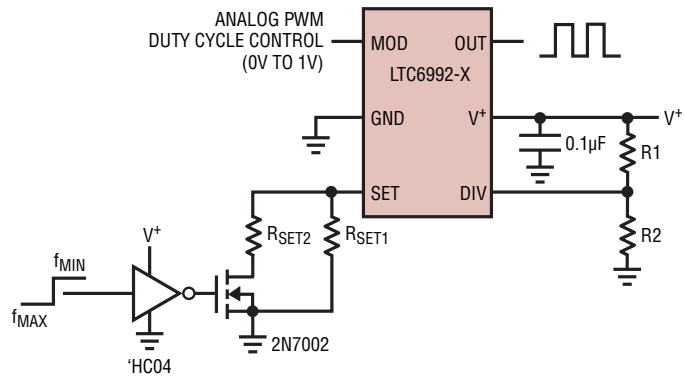

NOTES  
1. WHEN THE NMOSFET IS OFF, THE FREQUENCY IS SET BY  $R_{SET} = R_{SET1}$ .  
2. WHEN THE NMOSFET IS ON, THE FREQUENCY IS SET BY  $R_{SET} = R_{SET1} \parallel R_{SET2}$ .  
3.  $V^+$  SUPPLY VARIATION IS NOT A FACTOR AS THE SWITCHING RESISTOR IS EITHER FLOATING OR CONNECTED TO GROUND.

### Simple Diode Temperature Sensor

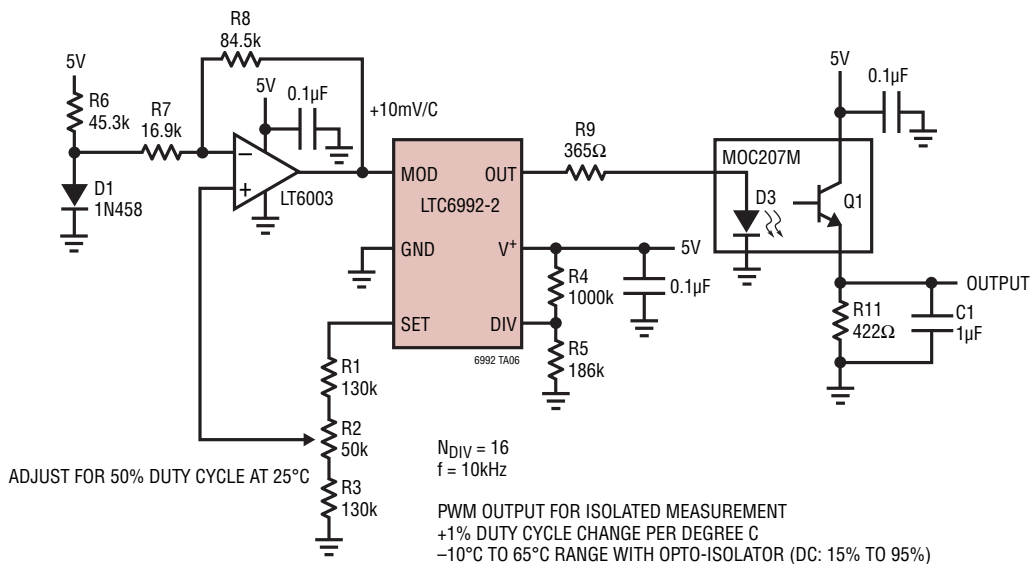

## TYPICAL APPLICATIONS

Motor Speed/Direction Control for Full H-Bridge (Locked Anti-Phase Drive)

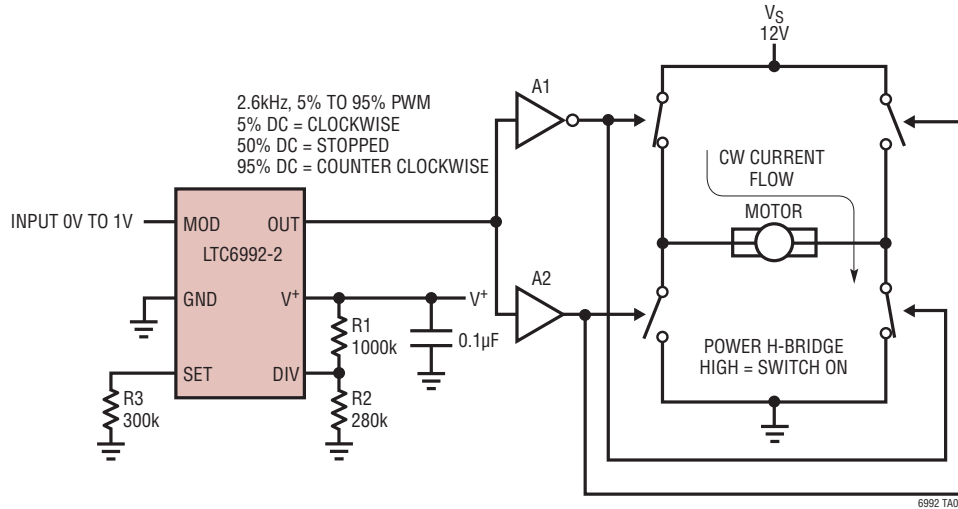

Motor Speed/Direction Control for Full H-Bridge (Sign/Magnitude Drive)

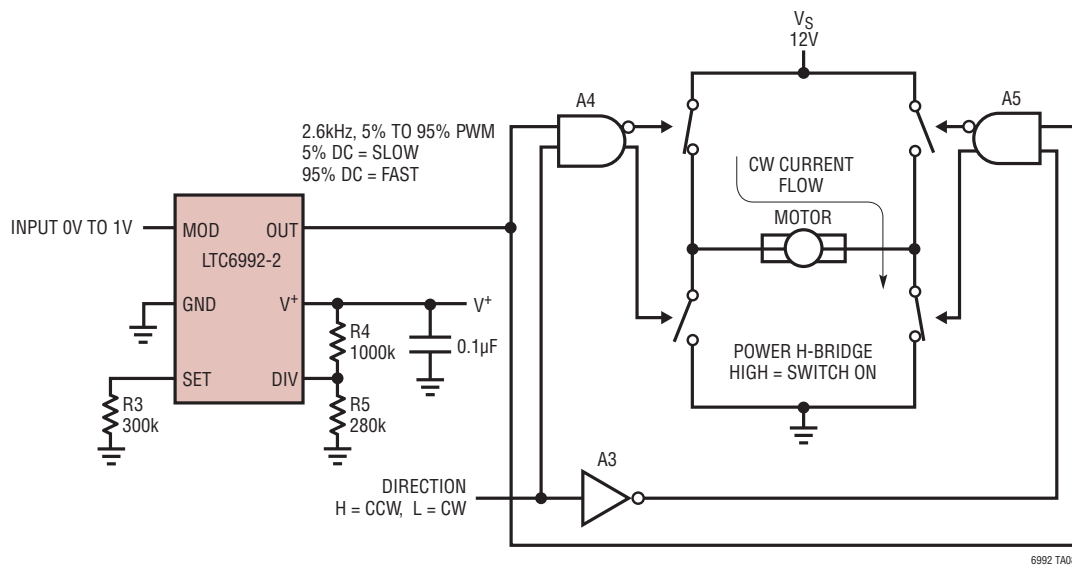

## TYPICAL APPLICATIONS

Ratiometric Sensor to Pulse Width, Non-Inverting Response

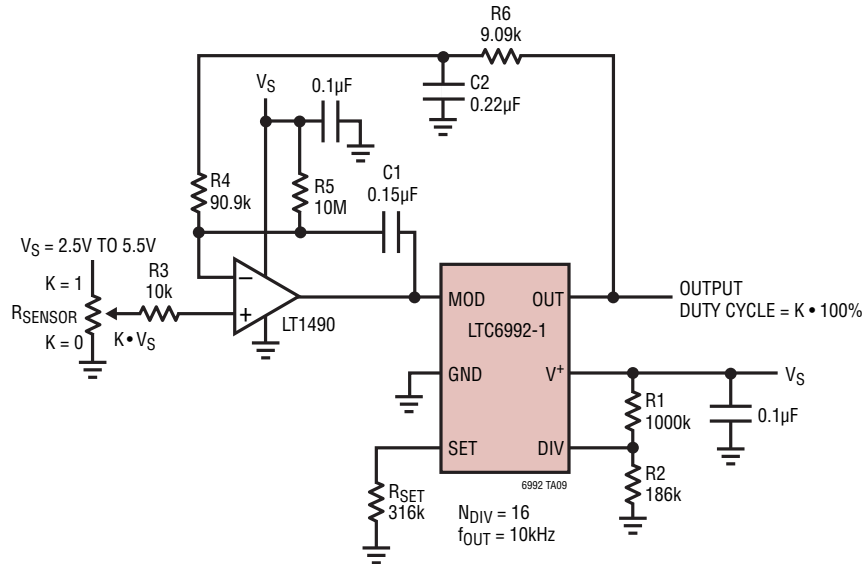

Ratiometric Sensor to Pulse Width, Inverting Response

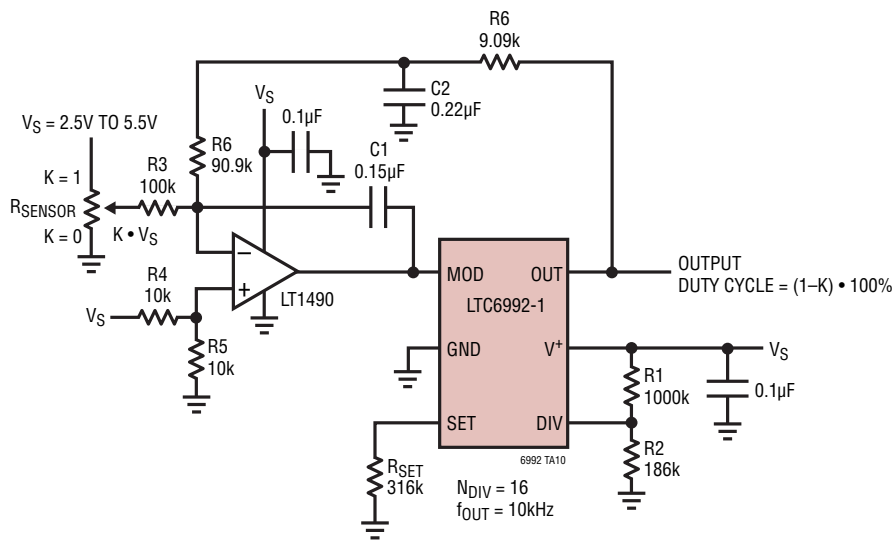

## TYPICAL APPLICATIONS

### Radio Control Servo Pulse Generator

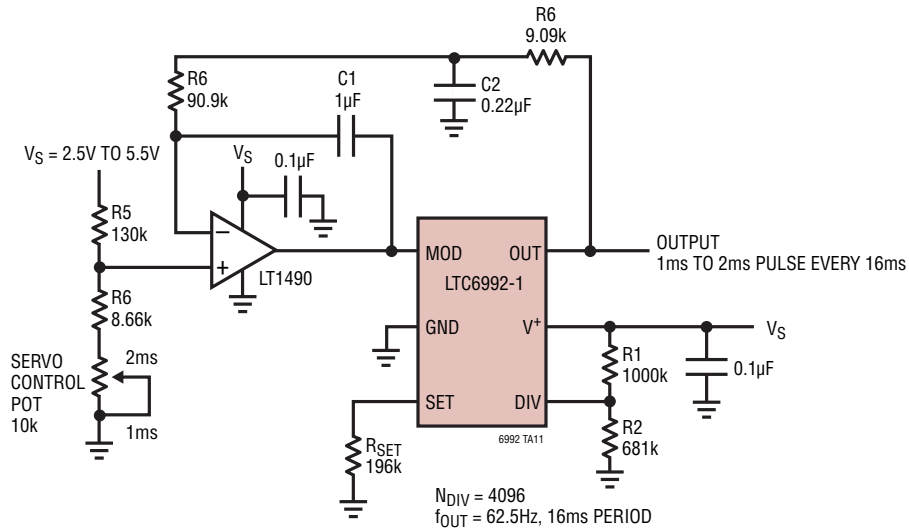

### Direct Voltage Controlled PWM Dimming (0 to 15000 Cd/m<sup>2</sup> Intensity)

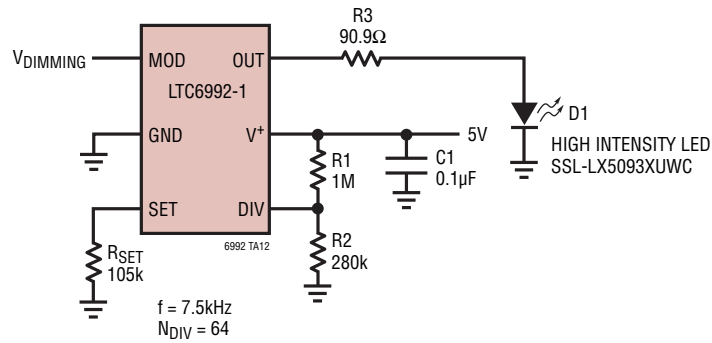

## TYPICAL APPLICATIONS

Wide Range LED Dimming (0 to 85000 Cd/m<sup>2</sup> Brightness)

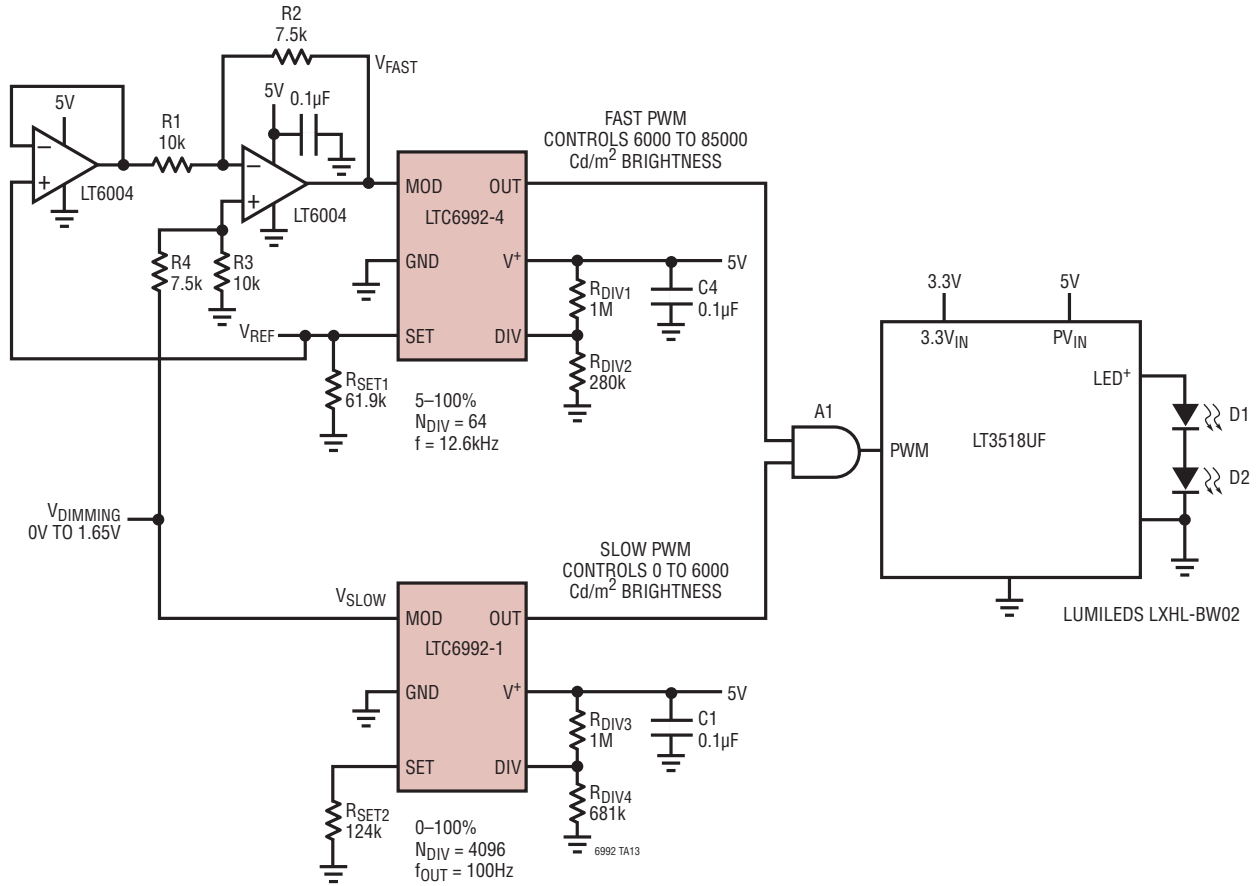

## TYPICAL APPLICATIONS

### Isolated PWM (5% to 95%) Controller

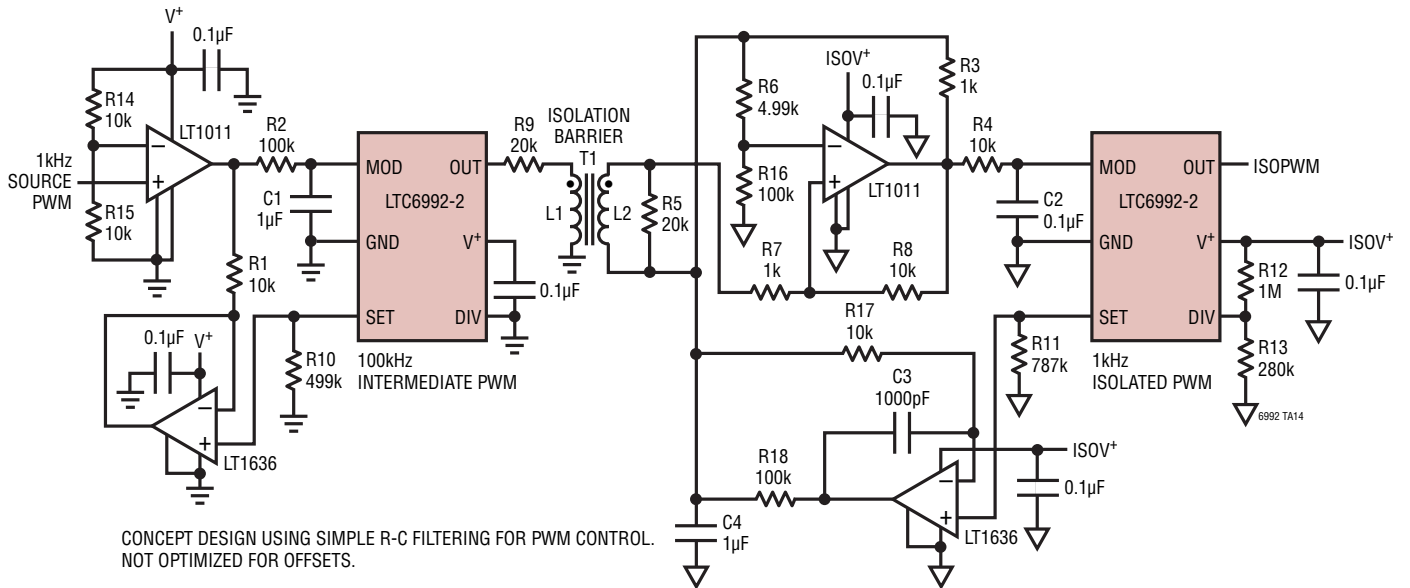

CONCEPT DESIGN USING SIMPLE R-C FILTERING FOR PWM CONTROL.  
NOT OPTIMIZED FOR OFFSETS.

T1: PCA EPF8119S ETHERNET TRANSFORMER

## PACKAGE DESCRIPTION

Please refer to <http://www.linear.com/designtools/packaging/> for the most recent package drawings.

**DCB Package**  
**6-Lead Plastic DFN (2mm × 3mm)**  
(Reference LTC DWG # 05-08-1715 Rev A)

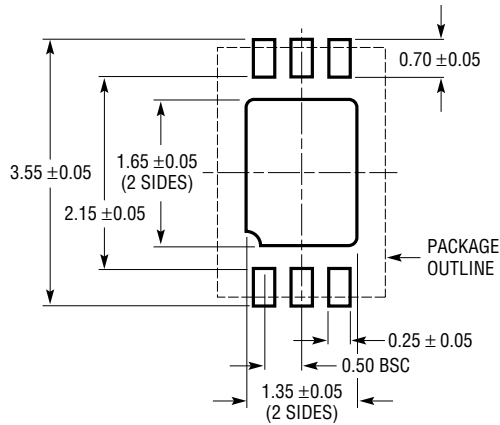

RECOMMENDED SOLDER PAD PITCH AND DIMENSIONS

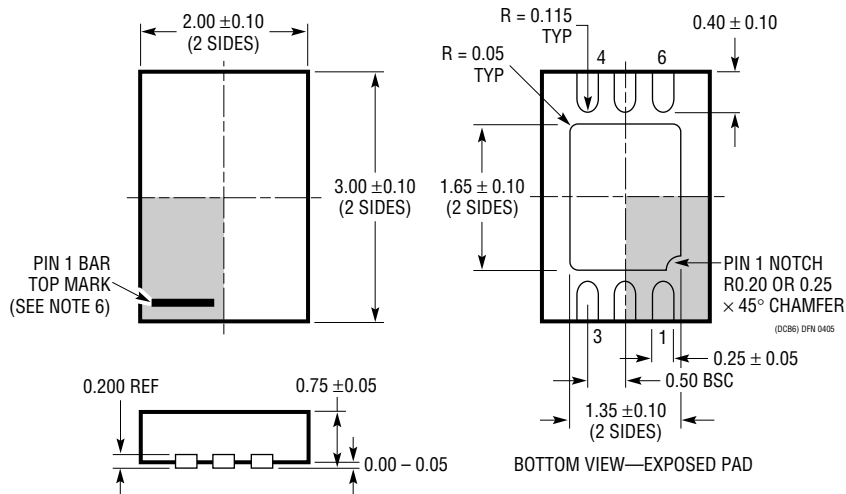

**NOTE:**

1. DRAWING TO BE MADE A JEDEC PACKAGE OUTLINE M0-229 VARIATION OF (TBD)
2. DRAWING NOT TO SCALE
3. ALL DIMENSIONS ARE IN MILLIMETERS
4. DIMENSIONS OF EXPOSED PAD ON BOTTOM OF PACKAGE DO NOT INCLUDE MOLD FLASH. MOLD FLASH, IF PRESENT, SHALL NOT EXCEED 0.15mm ON ANY SIDE
5. EXPOSED PAD SHALL BE SOLDER PLATED
6. SHADED AREA IS ONLY A REFERENCE FOR PIN 1 LOCATION ON THE TOP AND BOTTOM OF PACKAGE

## PACKAGE DESCRIPTION

Please refer to <http://www.linear.com/designtools/packaging/> for the most recent package drawings.

### S6 Package 6-Lead Plastic TSOT-23

(Reference LTC DWG # 05-08-1636 Rev B)

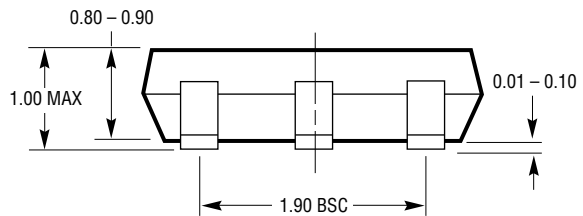
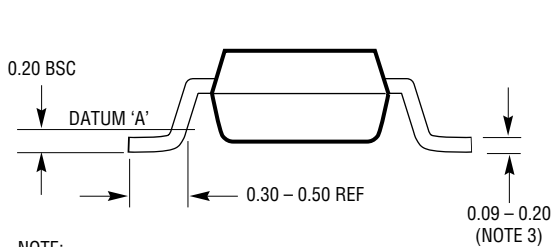
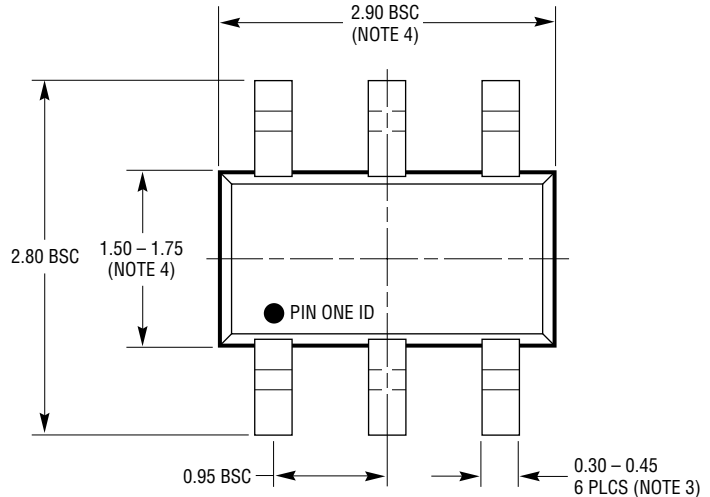
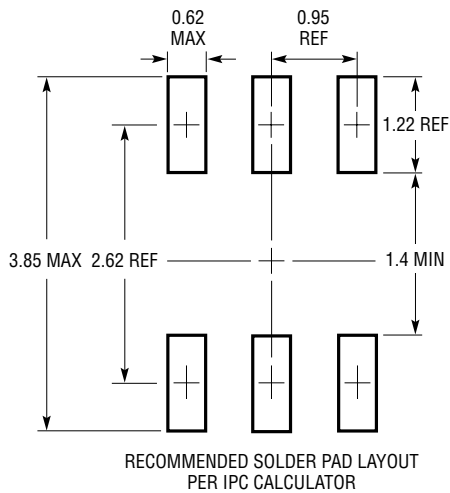

S6 TSOT-23 0302 REV B

- NOTE:
1. DIMENSIONS ARE IN MILLIMETERS
  2. DRAWING NOT TO SCALE
  3. DIMENSIONS ARE INCLUSIVE OF PLATING
  4. DIMENSIONS ARE EXCLUSIVE OF MOLD FLASH AND METAL BURR
  5. MOLD FLASH SHALL NOT EXCEED 0.254mm
  6. JEDEC PACKAGE REFERENCE IS MO-193

## REVISION HISTORY

REV	DATE	DESCRIPTION	PAGE NUMBER
A	01/11	Revised $\theta_{JA}$ value for TSOT package in the Pin Configuration.	2
		Added Note 7 for $V_{OH}$ and $V_{OL}$ in the Electrical Characteristics table.	4
		Minor edit to the Block Diagram.	12
		Minor edit to the equation in the "Duty Cycle Sensitivity to $\Delta V_{SET}$ " section.	19
		Revised Typical Applications drawings.	25
B	07/11	Revised Description and Order Information sections	1 to 3
		Added additional information to $\Delta f_{OUT}/\Delta V^+$ and included Note 11 in Electrical Characteristics section	3, 4
		Added Typical Frequency Error vs Time curve to Typical Performance Characteristics section	11
		Added text to Basic Operation paragraph in Applications Information section	19
		Corrected $f_{OUT}$ value in Typical Applications drawing 6692 TA13	29
C	01/12	Added MP-Grade	1, 2, 3, 5

# LTC6992-1/LTC6992-2/ LTC6992-3/LTC6992-4

## TYPICAL APPLICATION

PWM Controller for LED Driver

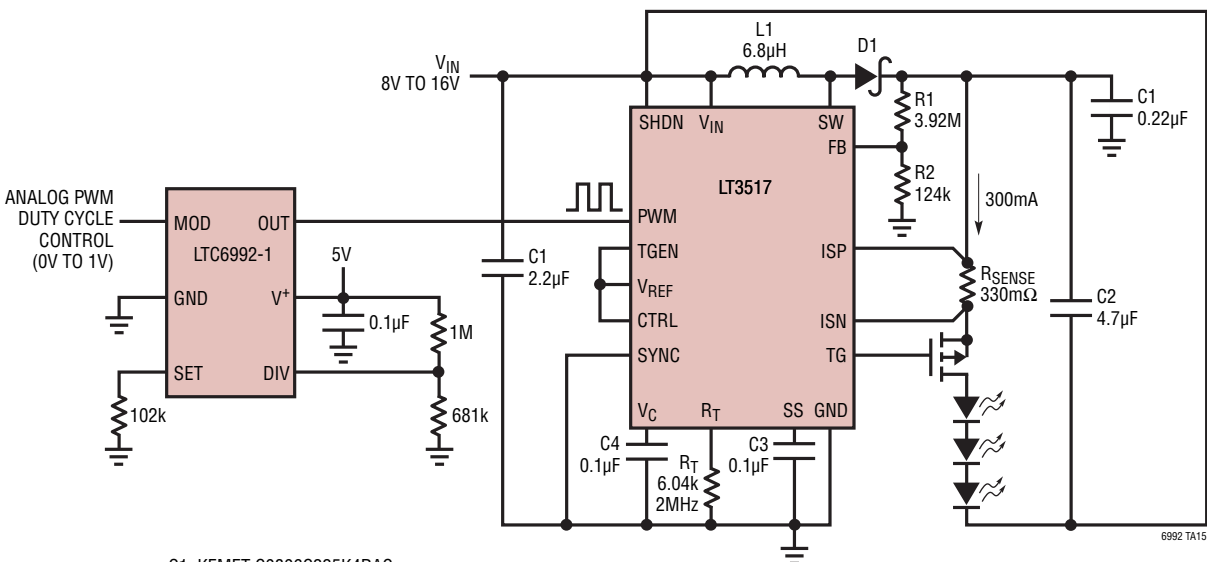

- C1: KEMET C0806C225K4RAC
- C2: KEMET C1206C475K3RAC
- C3, C4: MURATA GRM21BR71H104KA01B
- C5: MURATA GRM21BR71H224KA01B
- D1: DIODE DFSL160
- L1: TOKO B992AS-6R8N
- LEDS: LUXEON I (WHITE)
- M1: ZETEX ZXMP6A13FTA

## RELATED PARTS

PART NUMBER	DESCRIPTION	COMMENTS
LTC1799	1MHz to 33MHz ThinSOT Silicon Oscillator	Wide Frequency Range
LTC6900	1MHz to 20MHz ThinSOT Silicon Oscillator	Low Power, Wide Frequency Range
LTC6906/LTC6907	10kHz to 1MHz or 40kHz ThinSOT Silicon Oscillator	Micropower, $I_{SUPPLY} = 35\mu A$ at 400kHz
LTC6930	Fixed Frequency Oscillator, 32.768kHz to 8.192MHz	0.09% Accuracy, 110µs Start-Up Time, 105µA at 32kHz
LTC6990	TimerBlox, Voltage Controlled Oscillator	Frequency from 488Hz to 1MHz, No Caps, 2.2% Accurate
LTC6991	TimerBlox, Very Low Frequency Clock with Reset	Cycle Time from 2ms to 9.5 Hours, No Caps, 2.2% Accurate
LTC6993	TimerBlox, Monostable Pulse Generator	Resistor Set Pulse Width from 1µs to 34sec, No Caps, 3% Accurate
LTC6994	TimerBlox, Delay Block/Debouncer	Resistor Set Delay from 1µs to 34sec, No Caps Required, 3% Accurate

69921234fc