

74HC193-Q100; 74HCT193-Q100

Presetable synchronous 4-bit binary up/down counter

Rev. 1 — 12 July 2013

Product data sheet

1. General description

The 74HC193-Q100; 74HCT193-Q100 is a 4-bit synchronous binary up/down counter. Separate up/down clocks, CPU and CPD respectively, simplify operation. The outputs change state synchronously with the LOW-to-HIGH transition of either clock input. If the CPU clock is pulsed while CPD is held HIGH, the device counts up. If the CPD clock is pulsed while CPU is held HIGH, the device counts down. Only one clock input can be held HIGH at any time to guarantee predictable behavior. The device can be cleared at any time by the asynchronous master reset input (\overline{MR}). It may also be loaded in parallel by activating the asynchronous parallel load input (\overline{PL}). The terminal count up (\overline{TCU}) and terminal count down (\overline{TCD}) outputs are normally HIGH. When the circuit has reached the maximum count state of 15, the next HIGH-to-LOW transition of CPU causes \overline{TCU} to go LOW. \overline{TCU} remains LOW until CPU goes HIGH again, duplicating the count up clock. Likewise, the \overline{TCD} output goes LOW when the circuit is in the zero state and the CPD goes LOW. The terminal count outputs duplicate the clock waveforms and can be used as the clock input signals to the next higher-order circuit in a multistage counter. Multistage counters are not fully synchronous, since there is a slight delay time difference added for each stage that is added. The counter may be preset by the asynchronous parallel load capability of the circuit. Information on the parallel data inputs (D0 to D3), is loaded into the counter. This information appears on the outputs ($\overline{Q0}$ to $\overline{Q3}$) regardless of the conditions of the clock inputs when the parallel load (\overline{PL}) input is LOW. A HIGH level on the master reset (\overline{MR}) input disables the parallel load gates. It overrides both clock inputs and sets all outputs ($\overline{Q0}$ to $\overline{Q3}$) LOW. If one of the clock inputs is LOW during and after a reset or load operation, the next LOW-to-HIGH transition of that clock is interpreted as a legitimate signal and it is counted. Inputs include clamp diodes that enable the use of current limiting resistors to interface inputs to voltages in excess of V_{CC} .

This product has been qualified to the Automotive Electronics Council (AEC) standard Q100 (Grade 1) and is suitable for use in automotive applications.

2. Features and benefits

- Automotive product qualification in accordance with AEC-Q100 (Grade 1)
 - ◆ Specified from $-40\text{ }^{\circ}\text{C}$ to $+85\text{ }^{\circ}\text{C}$ and from $-40\text{ }^{\circ}\text{C}$ to $+125\text{ }^{\circ}\text{C}$
- Input levels:
 - ◆ For 74HC193-Q100: CMOS level
 - ◆ For 74HCT193-Q100: TTL level
- Synchronous reversible 4-bit binary counting
- Asynchronous parallel load
- Asynchronous reset
- Expandable without external logic
- Complies with JEDEC standard no. 7A



- ESD protection:
 - ◆ MIL-STD-883, method 3015 exceeds 2000 V
 - ◆ HBM JESD22-A114F exceeds 2000 V
 - ◆ MM JESD22-A115-A exceeds 200 V (C = 200 pF, R = 0 Ω)
- Multiple package options

3. Ordering information

Table 1. Ordering information

Type number	Package			Version
	Temperature range	Name	Description	
74HC193D-Q100	-40 °C to +125 °C	SO16	plastic small outline package; 16 leads; body width 3.9 mm	SOT109-1
74HC193DB-Q100	-40 °C to +125 °C	SSOP16	plastic shrink small outline package; 16 leads; body width 5.3 mm	SOT338-1
74HC193PW-Q100	-40 °C to +125 °C	TSSOP16	plastic thin shrink small outline package; 16 leads; body width 4.4 mm	SOT403-1
74HCT193D-Q100	-40 °C to +125 °C	SO16	plastic small outline package; 16 leads; body width 3.9 mm	SOT109-1
74HCT193DB-Q100	-40 °C to +125 °C	SSOP16	plastic shrink small outline package; 16 leads; body width 5.3 mm	SOT338-1
74HCT193PW-Q100	-40 °C to +125 °C	TSSOP16	plastic thin shrink small outline package; 16 leads; body width 4.4 mm	SOT403-1

4. Functional diagram

Fig 1. Functional diagram

Fig 2. Logic symbol

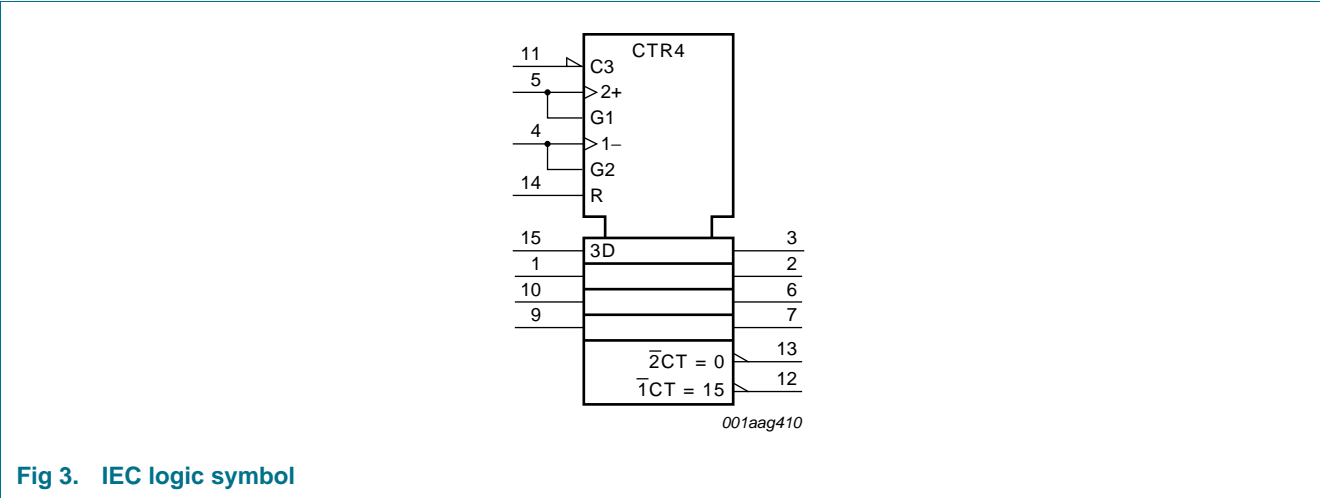
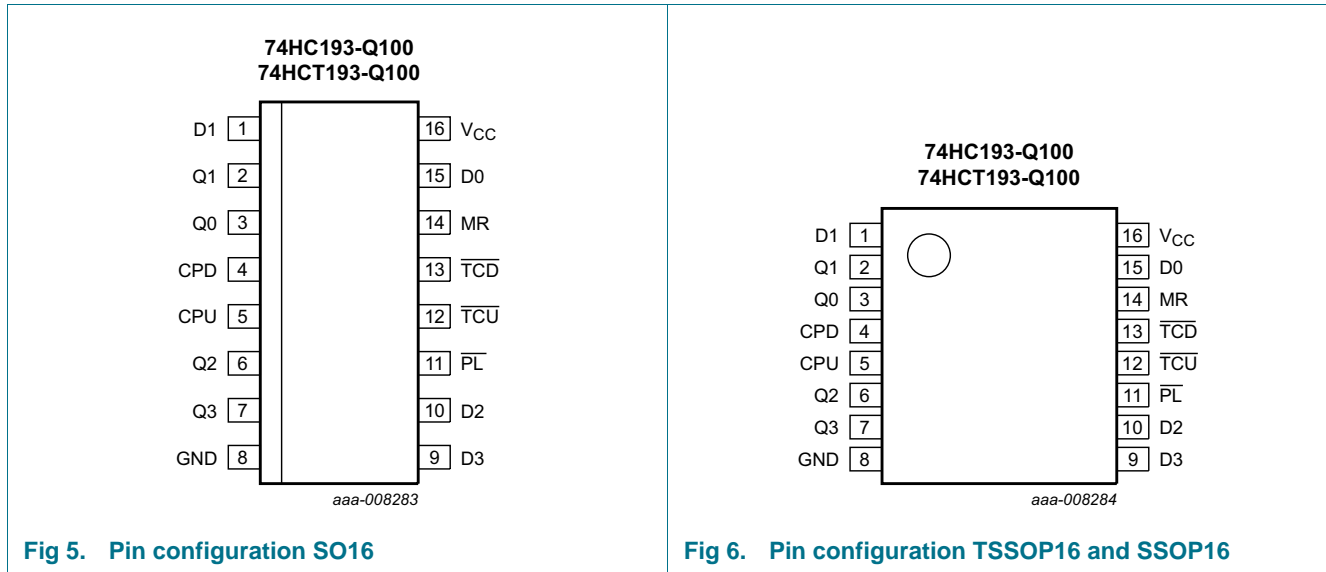

Fig 3. IEC logic symbol

5. Pinning information

5.1 Pinning



5.2 Pin description

Table 2. Pin description

Symbol	Pin	Description
D0	15	data input 0
D1	1	data input 1
D2	10	data input 2
D3	9	data input 3
Q0	3	flip-flop output 0
Q1	2	flip-flop output 1
Q2	6	flip-flop output 2
Q3	7	flip-flop output 3
CPD	4	count down clock input ^[1]
CPU	5	count up clock input ^[1]
GND	8	ground (0 V)
$\overline{\text{PL}}$	11	asynchronous parallel load input (active LOW)
$\overline{\text{TCU}}$	12	terminal count up (carry) output (active LOW)
$\overline{\text{TCD}}$	13	terminal count down (borrow) output (active LOW)
MR	14	asynchronous master reset input (active HIGH)
V _{CC}	16	supply voltage

[1] LOW-to-HIGH, edge triggered.

6. Functional description

Table 3. Function table^[1]

Operating mode	Inputs								Outputs					
	MR	$\overline{\text{PL}}$	CPU	CPD	D0	D1	D2	D3	Q0	Q1	Q2	Q3	$\overline{\text{TCU}}$	$\overline{\text{TCD}}$
Reset (clear)	H	X	X	L	X	X	X	X	L	L	L	L	H	L
	H	X	X	H	X	X	X	X	L	L	L	L	H	H
Parallel load	L	L	X	L	L	L	L	L	L	L	L	L	H	L
	L	L	X	H	L	L	L	L	L	L	L	L	H	H
	L	L	L	X	H	H	H	H	H	H	H	H	L	H
	L	L	H	X	H	H	H	H	H	H	H	H	H	H
Count up	L	H	↑	H	X	X	X	X	count up				H ^[2]	H
Count down	L	H	H	↑	X	X	X	X	count down				H	H ^[3]

- [1] H = HIGH voltage level
 L = LOW voltage level
 X = don't care
 ↑ = LOW-to-HIGH clock transition.

[2] $\overline{\text{TCU}}$ = CPU at terminal count up (HHHH)

[3] $\overline{\text{TCD}}$ = CPD at terminal count down (LLLL).

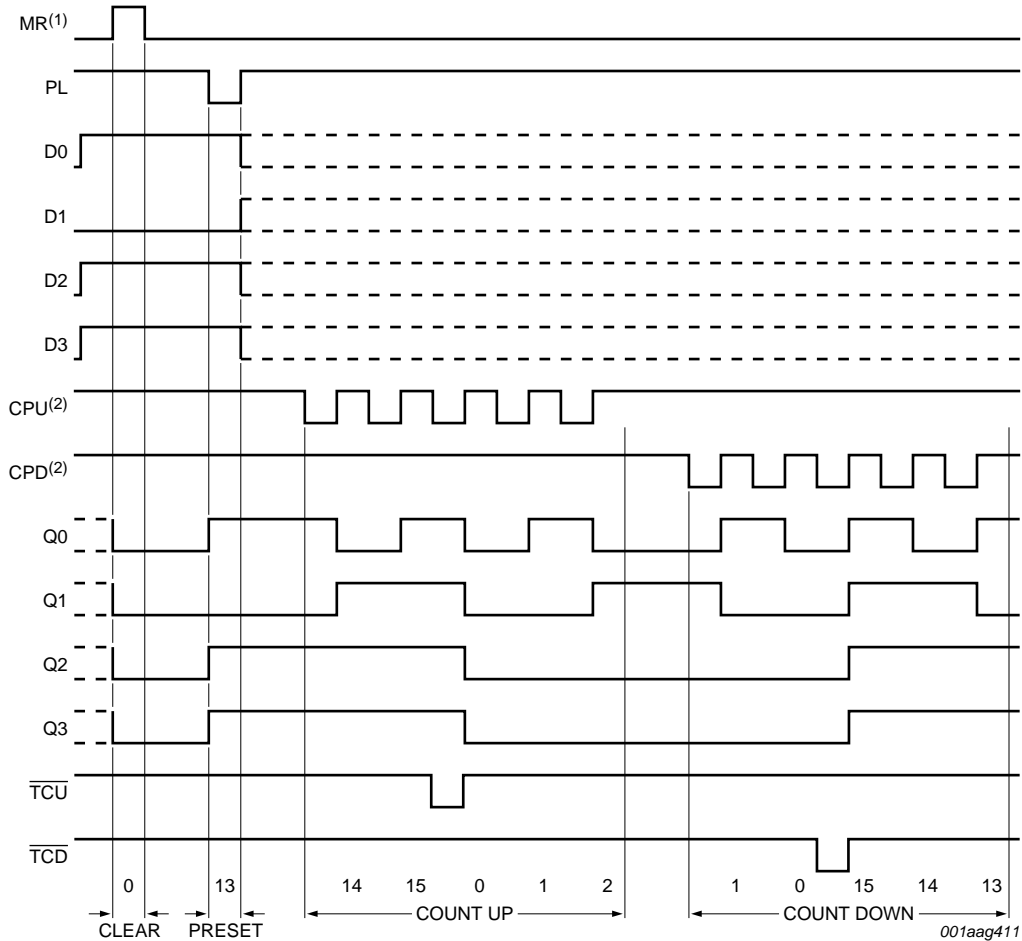

- (1) Clear overrides load, data and count inputs.
- (2) When counting up, the count down clock input (CPD) must be HIGH, when counting down the count up clock input (CPU) must be HIGH.

Sequence

Clear (reset outputs to zero);
 load (preset) to binary thirteen;
 count up to fourteen, fifteen, terminal count up, zero, one and two;
 count down to one, zero, terminal count down, fifteen, fourteen and thirteen.

Fig 7. Typical clear, load and count sequence

7. Limiting values

Table 4. Limiting values

In accordance with the Absolute Maximum Rating System (IEC 60134). Voltages are referenced to GND (ground = 0 V).

Symbol	Parameter	Conditions	Min	Max	Unit
V_{CC}	supply voltage		-0.5	+7.0	V
I_{IK}	input clamping current	$V_I < -0.5\text{ V}$ or $V_I > V_{CC} + 0.5\text{ V}$	[1] -	±20	mA
I_{OK}	output clamping current	$V_O < -0.5\text{ V}$ or $V_O > V_{CC} + 0.5\text{ V}$	[1] -	±20	mA
I_O	output current	$V_O = -0.5\text{ V}$ to $V_{CC} + 0.5\text{ V}$	-	±25	mA
I_{CC}	supply current		-	50	mA
I_{GND}	ground current		-	-50	mA
T_{stg}	storage temperature		-65	+150	°C
P_{tot}	total power dissipation		[2] -	500	mW

[1] The input and output voltage ratings may be exceeded if the input and output current ratings are observed.

[2] For SO16 packages: above 70 °C the value of P_{tot} derates linearly at 8 mW/K.

For SSOP16 and TSSOP16 packages: above 60 °C the value of P_{tot} derates linearly at 5.5 mW/K.

8. Recommended operating conditions

Table 5. Recommended operating conditions

Symbol	Parameter	Conditions	Min	Typ	Max	Unit
74HC193-Q100						
V_{CC}	supply voltage		2.0	5.0	6.0	V
V_I	input voltage		0	-	V_{CC}	V
V_O	output voltage		0	-	V_{CC}	V
T_{amb}	ambient temperature		-40	+25	+125	°C
$\Delta t/\Delta V$	input transition rise and fall rate	$V_{CC} = 2.0\text{ V}$	-	-	625	ns/V
		$V_{CC} = 4.5\text{ V}$	-	1.67	139	ns/V
		$V_{CC} = 6.0\text{ V}$	-	-	83	ns/V
74HCT193-Q100						
V_{CC}	supply voltage		4.5	5.0	5.5	V
V_I	input voltage		0	-	V_{CC}	V
V_O	output voltage		0	-	V_{CC}	V
T_{amb}	ambient temperature		-40	+25	+125	°C
$\Delta t/\Delta V$	input transition rise and fall rate	$V_{CC} = 4.5\text{ V}$	-	1.67	139	ns/V

9. Static characteristics

Table 6. Static characteristics type 74HC193-Q100

At recommended operating conditions; voltages are referenced to GND (ground = 0 V).

Symbol	Parameter	Conditions	Min	Typ	Max	Unit
T_{amb} = 25 °C						
V _{IH}	HIGH-level input voltage	V _{CC} = 2.0 V	1.5	1.2	-	V
		V _{CC} = 4.5 V	3.15	2.4	-	V
		V _{CC} = 6.0 V	4.2	3.2	-	V
V _{IL}	LOW-level input voltage	V _{CC} = 2.0 V	-	0.8	0.5	V
		V _{CC} = 4.5 V	-	2.1	1.35	V
		V _{CC} = 6.0 V	-	2.8	1.8	V
V _{OH}	HIGH-level output voltage	V _I = V _{IH} or V _{IL}	-	-	-	
		I _O = -20 μA; V _{CC} = 2.0 V	1.9	2.0	-	V
		I _O = -20 μA; V _{CC} = 4.5 V	4.4	4.5	-	V
		I _O = -20 μA; V _{CC} = 6.0 V	5.9	6.0	-	V
		I _O = -4.0 mA; V _{CC} = 4.5 V	3.98	4.32	-	V
		I _O = -5.2 mA; V _{CC} = 6.0 V	5.48	5.81	-	V
V _{OL}	LOW-level output voltage	V _I = V _{IH} or V _{IL}	-	-	-	
		I _O = 20 μA; V _{CC} = 2.0 V	-	0	0.1	V
		I _O = 20 μA; V _{CC} = 4.5 V	-	0	0.1	V
		I _O = 20 μA; V _{CC} = 6.0 V	-	0	0.1	V
		I _O = 4.0 mA; V _{CC} = 4.5 V	-	0.15	0.26	V
		I _O = 5.2 mA; V _{CC} = 6.0 V	-	0.16	0.26	V
I _I	input leakage current	V _I = V _{CC} or GND; V _{CC} = 6.0 V	-	-	±0.1	μA
I _{CC}	supply current	V _I = V _{CC} or GND; I _O = 0 A; V _{CC} = 6.0 V	-	-	8.0	μA
C _i	input capacitance		-	3.5	-	pF
T_{amb} = -40 °C to +85 °C						
V _{IH}	HIGH-level input voltage	V _{CC} = 2.0 V	1.5	-	-	V
		V _{CC} = 4.5 V	3.15	-	-	V
		V _{CC} = 6.0 V	4.2	-	-	V
V _{IL}	LOW-level input voltage	V _{CC} = 2.0 V	-	-	0.5	V
		V _{CC} = 4.5 V	-	-	1.35	V
		V _{CC} = 6.0 V	-	-	1.8	V
V _{OH}	HIGH-level output voltage	V _I = V _{IH} or V _{IL}	-	-	-	
		I _O = -20 μA; V _{CC} = 2.0 V	1.9	-	-	V
		I _O = -20 μA; V _{CC} = 4.5 V	4.4	-	-	V
		I _O = -20 μA; V _{CC} = 6.0 V	5.9	-	-	V
		I _O = -4.0 mA; V _{CC} = 4.5 V	3.84	-	-	V
		I _O = -5.2 mA; V _{CC} = 6.0 V	5.34	-	-	V

Table 6. Static characteristics type 74HC193-Q100 ...continued

At recommended operating conditions; voltages are referenced to GND (ground = 0 V).

Symbol	Parameter	Conditions	Min	Typ	Max	Unit
V _{OL}	LOW-level output voltage	V _I = V _{IH} or V _{IL}				
		I _O = 20 μA; V _{CC} = 2.0 V	-	-	0.1	V
		I _O = 20 μA; V _{CC} = 4.5 V	-	-	0.1	V
		I _O = 20 μA; V _{CC} = 6.0 V	-	-	0.1	V
		I _O = 4.0 mA; V _{CC} = 4.5 V	-	-	0.33	V
		I _O = 5.2 mA; V _{CC} = 6.0 V	-	-	0.33	V
I _I	input leakage current	V _I = V _{CC} or GND; V _{CC} = 6.0 V	-	-	±1.0	μA
I _{CC}	supply current	V _I = V _{CC} or GND; I _O = 0 A; V _{CC} = 6.0 V	-	-	80	μA
T _{amb} = -40 °C to +125 °C						
V _{IH}	HIGH-level input voltage	V _{CC} = 2.0 V	1.5	-	-	V
		V _{CC} = 4.5 V	3.15	-	-	V
		V _{CC} = 6.0 V	4.2	-	-	V
V _{IL}	LOW-level input voltage	V _{CC} = 2.0 V	-	-	0.5	V
		V _{CC} = 4.5 V	-	-	1.35	V
		V _{CC} = 6.0 V	-	-	1.8	V
V _{OH}	HIGH-level output voltage	V _I = V _{IH} or V _{IL}				
		I _O = -20 μA; V _{CC} = 2.0 V	1.9	-	-	V
		I _O = -20 μA; V _{CC} = 4.5 V	4.4	-	-	V
		I _O = -20 μA; V _{CC} = 6.0 V	5.9	-	-	V
		I _O = -4.0 mA; V _{CC} = 4.5 V	3.7	-	-	V
		I _O = -5.2 mA; V _{CC} = 6.0 V	5.2	-	-	V
V _{OL}	LOW-level output voltage	V _I = V _{IH} or V _{IL}				
		I _O = 20 μA; V _{CC} = 2.0 V	-	-	0.1	V
		I _O = 20 μA; V _{CC} = 4.5 V	-	-	0.1	V
		I _O = 20 μA; V _{CC} = 6.0 V	-	-	0.1	V
		I _O = 4.0 mA; V _{CC} = 4.5 V	-	-	0.4	V
		I _O = 5.2 mA; V _{CC} = 6.0 V	-	-	0.4	V
I _I	input leakage current	V _I = V _{CC} or GND; V _{CC} = 6.0 V	-	-	±1.0	μA
I _{CC}	supply current	V _I = V _{CC} or GND; I _O = 0 A; V _{CC} = 6.0 V	-	-	160	μA

Table 7. Static characteristics type 74HCT193-Q100

At recommended operating conditions; voltages are referenced to GND (ground = 0 V).

Symbol	Parameter	Conditions	Min	Typ	Max	Unit
T_{amb} = 25 °C						
V _{IH}	HIGH-level input voltage	V _{CC} = 4.5 V to 5.5 V	2.0	1.6	-	V
V _{IL}	LOW-level input voltage	V _{CC} = 4.5 V to 5.5 V	-	1.2	0.8	V
V _{OH}	HIGH-level output voltage	V _I = V _{IH} or V _{IL} ; V _{CC} = 4.5 V				
		I _O = -20 μA	4.4	4.5	-	V
		I _O = -4.0 mA	3.98	4.32	-	V
V _{OL}	LOW-level output voltage	V _I = V _{IH} or V _{IL} ; V _{CC} = 4.5 V				
		I _O = 20 μA	-	0	0.1	V
		I _O = 4.0 mA	-	0.15	0.26	V
I _I	input leakage current	V _I = V _{CC} or GND; V _{CC} = 5.5 V	-	-	±0.1	μA
I _{CC}	supply current	V _I = V _{CC} or GND; I _O = 0 A; V _{CC} = 5.5 V	-	-	8.0	μA
ΔI _{CC}	additional supply current	per input pin; V _I = V _{CC} - 2.1 V and other inputs at V _{CC} or GND; I _O = 0 A; V _{CC} = 4.5 V to 5.5 V				
		pin Dn	-	35	126	μA
		pins CPU, CPD	-	140	504	μA
		pin \overline{PL}	-	65	234	μA
		pin MR	-	105	378	μA
C _i	input capacitance		-	3.5	-	pF
T_{amb} = -40 °C to +85 °C						
V _{IH}	HIGH-level input voltage	V _{CC} = 4.5 V to 5.5 V	2.0	-	-	V
V _{IL}	LOW-level input voltage	V _{CC} = 4.5 V to 5.5 V	-	-	0.8	V
V _{OH}	HIGH-level output voltage	V _I = V _{IH} or V _{IL} ; V _{CC} = 4.5 V				
		I _O = -20 μA	4.4	-	-	V
		I _O = -4.0 mA	3.84	-	-	V
V _{OL}	LOW-level output voltage	V _I = V _{IH} or V _{IL} ; V _{CC} = 4.5 V				
		I _O = 20 μA	-	-	0.1	V
		I _O = 4.0 mA	-	-	0.33	V
I _I	input leakage current	V _I = V _{CC} or GND; V _{CC} = 5.5 V	-	-	±1.0	μA
I _{CC}	supply current	V _I = V _{CC} or GND; I _O = 0 A; V _{CC} = 5.5 V	-	-	80	μA
ΔI _{CC}	additional supply current	per input pin; V _I = V _{CC} - 2.1 V and other inputs at V _{CC} or GND; I _O = 0 A; V _{CC} = 4.5 V to 5.5 V				
		pin Dn	-	-	157.5	μA
		pins CPU, CPD	-	-	630	μA
		pin \overline{PL}	-	-	292.5	μA
		pin MR	-	-	472.5	μA

Table 7. Static characteristics type 74HCT193-Q100 ...continued

At recommended operating conditions; voltages are referenced to GND (ground = 0 V).

Symbol	Parameter	Conditions	Min	Typ	Max	Unit
T_{amb} = -40 °C to +125 °C						
V _{IH}	HIGH-level input voltage	V _{CC} = 4.5 V to 5.5 V	2.0	-	-	V
V _{IL}	LOW-level input voltage	V _{CC} = 4.5 V to 5.5 V	-	-	0.8	V
V _{OH}	HIGH-level output voltage	V _I = V _{IH} or V _{IL} ; V _{CC} = 4.5 V				
		I _O = -20 μA	4.4	-	-	V
		I _O = -4.0 mA	3.7	-	-	V
V _{OL}	LOW-level output voltage	V _I = V _{IH} or V _{IL} ; V _{CC} = 4.5 V				
		I _O = 20 μA	-	-	0.1	V
		I _O = 4.0 mA	-	-	0.4	V
I _I	input leakage current	V _I = V _{CC} or GND; V _{CC} = 5.5 V	-	-	±1.0	μA
I _{CC}	supply current	V _I = V _{CC} or GND; I _O = 0 A; V _{CC} = 5.5 V	-	-	160	μA
ΔI _{CC}	additional supply current	per input pin; V _I = V _{CC} - 2.1 V and other inputs at V _{CC} or GND; I _O = 0 A; V _{CC} = 4.5 V to 5.5 V				
		pin Dn	-	-	171.5	μA
		pins CPU, CPD	-	-	686	μA
		pin $\overline{\text{PL}}$	-	-	318.5	μA
		pin MR	-	-	514.5	μA

10. Dynamic characteristics

Table 8. Dynamic characteristics type 74HC193 -Q100

Symbol	Parameter	Conditions	25 °C			-40 °C to +85 °C		-40 °C to +125 °C		Unit
			Min	Typ	Max	Min	Max	Min	Max	
t _{pd}	propagation delay	CPU, CPD to Qn; see Figure 8	-	-	-	-	-	-	-	-
		V _{CC} = 2.0 V	-	63	215	-	270	-	325	ns
		V _{CC} = 4.5 V	-	23	43	-	54	-	65	ns
		V _{CC} = 6.0 V	-	18	37	-	46	-	55	ns
		CPU to TCU; see Figure 9	-	-	-	-	-	-	-	-
		V _{CC} = 2.0 V	-	39	125	-	155	-	190	ns
		V _{CC} = 4.5 V	-	14	25	-	31	-	38	ns
		V _{CC} = 6.0 V	-	11	21	-	26	-	32	ns
		CPD to TCD; see Figure 9	-	-	-	-	-	-	-	-
		V _{CC} = 2.0 V	-	39	125	-	155	-	190	ns
		V _{CC} = 4.5 V	-	14	25	-	31	-	38	ns
		V _{CC} = 6.0 V	-	11	21	-	26	-	32	ns
		PL to Qn; see Figure 10	-	-	-	-	-	-	-	-
		V _{CC} = 2.0 V	-	69	220	-	275	-	330	ns
		V _{CC} = 4.5 V	-	25	44	-	55	-	66	ns
		V _{CC} = 6.0 V	-	20	37	-	47	-	56	ns
		MR to Qn; see Figure 11	-	-	-	-	-	-	-	-
		V _{CC} = 2.0 V	-	58	200	-	250	-	300	ns
		V _{CC} = 4.5 V	-	21	40	-	50	-	60	ns
		V _{CC} = 6.0 V	-	17	34	-	43	-	51	ns
		Dn to Qn; see Figure 10	-	-	-	-	-	-	-	-
V _{CC} = 2.0 V	-	69	210	-	265	-	315	ns		
V _{CC} = 4.5 V	-	25	42	-	53	-	63	ns		
V _{CC} = 6.0 V	-	20	36	-	45	-	54	ns		
PL to TCU, PL to TCD; see Figure 13	-	-	-	-	-	-	-	-		
V _{CC} = 2.0 V	-	80	290	-	365	-	435	ns		
V _{CC} = 4.5 V	-	29	58	-	73	-	87	ns		
V _{CC} = 6.0 V	-	23	49	-	62	-	74	ns		
MR to TCU, MR to TCD; see Figure 13	-	-	-	-	-	-	-	-		
V _{CC} = 2.0 V	-	74	285	-	355	-	430	ns		
V _{CC} = 4.5 V	-	27	57	-	71	-	86	ns		
V _{CC} = 6.0 V	-	22	48	-	60	-	73	ns		

Table 8. Dynamic characteristics type 74HC193 ...continued-Q100

Symbol	Parameter	Conditions	25 °C			-40 °C to +85 °C		-40 °C to +125 °C		Unit		
			Min	Typ	Max	Min	Max	Min	Max			
t _{pd}	propagation delay	\overline{Dn} to \overline{TCU} , Dn to \overline{TCU} ; see Figure 13										
		V _{CC} = 2.0 V	-	80	290	-	365	-	435	ns		
		V _{CC} = 4.5 V	-	29	58	-	73	-	87	ns		
		V _{CC} = 6.0 V	-	23	49	-	62	-	74	ns		
t _{THL}	HIGH to LOW output transition time	see Figure 11										
		V _{CC} = 2.0 V	-	19	75	-	95	-	110	ns		
		V _{CC} = 4.5 V	-	7	15	-	19	-	22	ns		
		V _{CC} = 6.0 V	-	6	13	-	16	-	19	ns		
t _{TLH}	LOW to HIGH output transition time	see Figure 11										
		V _{CC} = 2.0 V	-	19	75	-	95	-	110	ns		
		V _{CC} = 4.5 V	-	7	15	-	19	-	22	ns		
		V _{CC} = 6.0 V	-	6	13	-	16	-	19	ns		
t _w	pulse width	CPU, CPD (HIGH or LOW); see Figure 8										
		V _{CC} = 2.0 V	100	22	-	125	-	150	-	ns		
		V _{CC} = 4.5 V	20	8	-	25	-	30	-	ns		
		V _{CC} = 6.0 V	17	6	-	21	-	26	-	ns		
		MR (HIGH); see Figure 11										
		V _{CC} = 2.0 V	100	25	-	125	-	150	-	ns		
		V _{CC} = 4.5 V	20	9	-	25	-	30	-	ns		
		V _{CC} = 6.0 V	17	7	-	21	-	26	-	ns		
		\overline{PL} (LOW); see Figure 10										
		V _{CC} = 2.0 V	100	19	-	125	-	150	-	ns		
		V _{CC} = 4.5 V	20	7	-	25	-	30	-	ns		
		V _{CC} = 6.0 V	17	6	-	21	-	26	-	ns		
		t _{rec}	recovery time	\overline{PL} to CPU, CPD; see Figure 10								
				V _{CC} = 2.0 V	50	8	-	65	-	75	-	ns
V _{CC} = 4.5 V	10			3	-	13	-	15	-	ns		
V _{CC} = 6.0 V	9			2	-	11	-	13	-	ns		
MR to CPU, CPD; see Figure 11												
V _{CC} = 2.0 V	50			0	-	65	-	75	-	ns		
V _{CC} = 4.5 V	10			0	-	13	-	15	-	ns		
V _{CC} = 6.0 V	9			0	-	11	-	13	-	ns		

Table 8. Dynamic characteristics type 74HC193 ...continued-Q100

Symbol	Parameter	Conditions	25 °C			-40 °C to +85 °C		-40 °C to +125 °C		Unit	
			Min	Typ	Max	Min	Max	Min	Max		
t _{su}	set-up time	Dn to \overline{PL} ; see Figure 12 ; note: CPU = CPD = HIGH	V _{CC} = 2.0 V	80	22	-	100	-	120	-	ns
			V _{CC} = 4.5 V	16	8	-	20	-	24	-	ns
			V _{CC} = 6.0 V	14	6	-	17	-	20	-	ns
t _h	hold time	Dn to \overline{PL} ; see Figure 12	V _{CC} = 2.0 V	0	-14	-	0	-	0	-	ns
			V _{CC} = 4.5 V	0	-5	-	0	-	0	-	ns
			V _{CC} = 6.0 V	0	-4	-	0	-	0	-	ns
		CPU to CPD, CPD to CPU; see Figure 14	V _{CC} = 2.0 V	80	22	-	100	-	120	-	ns
			V _{CC} = 4.5 V	16	8	-	20	-	24	-	ns
			V _{CC} = 6.0 V	8	6	-	17	-	20	-	ns
f _{max}	maximum frequency	CPU, CPD; see Figure 8	V _{CC} = 2.0 V	4.0	13.5	-	3.2	-	2.6	-	MHz
			V _{CC} = 4.5 V	20	41	-	16	-	13	-	MHz
			V _{CC} = 6.0 V	24	49	-	19	-	15	-	MHz
C _{PD}	power dissipation capacitance	V _I = GND to V _{CC} ; [2] V _{CC} = 5 V; f _i = 1 MHz	-	24	-	-	-	-	-	pF	

[1] t_{pd} is the same as t_{PHL} and t_{PLH}.

[2] C_{PD} is used to determine the dynamic power dissipation (P_D in μW):

$$P_D = C_{PD} \times V_{CC}^2 \times f_i \times N + \sum(C_L \times V_{CC}^2 \times f_o) \text{ where:}$$

f_i = input frequency in MHz;

f_o = output frequency in MHz;

C_L = output load capacitance in pF;

V_{CC} = supply voltage in V;

N = number of inputs switching;

$\sum(C_L \times V_{CC}^2 \times f_o)$ = sum of outputs.

Table 9. Dynamic characteristics type 74HCT193 -Q100

Symbol	Parameter	Conditions	25 °C			-40 °C to +85 °C		-40 °C to +125 °C		Unit
			Min	Typ	Max	Min	Max	Min	Max	
t _{pd}	propagation delay	CPU, CPD to Q _n ; see Figure 8 ^[1]								
		V _{CC} = 4.5 V	-	23	43	-	54	-	65	ns
		CPU to $\overline{\text{TCU}}$; see Figure 9								
		V _{CC} = 4.5 V	-	15	27	-	34	-	41	ns
		CPD to $\overline{\text{TCD}}$; see Figure 9								
		V _{CC} = 4.5 V	-	15	27	-	34	-	41	ns
		PL to Q _n ; see Figure 10								
		V _{CC} = 4.5 V	-	26	46	-	58	-	69	ns
		MR to Q _n ; see Figure 11								
		V _{CC} = 4.5 V	-	22	40	-	50	-	60	ns
t _{THL}	HIGH to LOW output transition time	Dn to Q _n ; see Figure 10								
		V _{CC} = 4.5 V	-	27	46	-	58	-	69	ns
		$\overline{\text{PL}}$ to $\overline{\text{TCU}}$, $\overline{\text{PL}}$ to $\overline{\text{TCD}}$; see Figure 13								
		V _{CC} = 4.5 V	-	31	55	-	69	-	83	ns
		MR to $\overline{\text{TCU}}$, MR to $\overline{\text{TCD}}$; see Figure 13								
		V _{CC} = 4.5 V	-	29	55	-	69	-	83	ns
		Dn to $\overline{\text{TCU}}$, Dn to $\overline{\text{TCD}}$; see Figure 13								
		V _{CC} = 4.5 V	-	32	58	-	73	-	87	ns
		see Figure 11								
		V _{CC} = 4.5 V	-	7	15	-	19	-	22	ns
t _{TLH}	LOW to HIGH output transition time	see Figure 11								
		V _{CC} = 4.5 V	-	7	15	-	19	-	22	ns
t _w	pulse width	CPU, CPD (HIGH or LOW); see Figure 8								
		V _{CC} = 4.5 V	25	11	-	31	-	38	-	ns
		MR (HIGH); see Figure 11								
		V _{CC} = 4.5 V	20	7	-	25	-	30	-	ns
t _w	pulse width	PL (LOW); see Figure 10								
		V _{CC} = 4.5 V	20	8	-	25	-	30	-	ns

Table 9. Dynamic characteristics type 74HCT193 ...continued-Q100

Symbol	Parameter	Conditions	25 °C			-40 °C to +85 °C		-40 °C to +125 °C		Unit
			Min	Typ	Max	Min	Max	Min	Max	
t _{rec}	recovery time	\overline{PL} to CPU, CPD; see Figure 10								
		V _{CC} = 4.5 V	10	2	-	13	-	15	-	ns
		MR to CPU, CPD; see Figure 11								
		V _{CC} = 4.5 V	10	0	-	13	-	15	-	ns
t _{su}	set-up time	Dn to \overline{PL} ; see Figure 12 ; note: CPU = CPD = HIGH								
		V _{CC} = 4.5 V	16	8	-	20	-	24	-	ns
t _h	hold time	Dn to \overline{PL} ; see Figure 12								
		V _{CC} = 4.5 V	0	-6	-	0	-	0	-	ns
		CPU to CPD, CPD to CPU; see Figure 14								
		V _{CC} = 4.5 V	16	7	-	20	-	24	-	ns
f _{max}	maximum frequency	CPU, CPD; see Figure 8								
		V _{CC} = 4.5 V	20	43	-	16	-	13	-	MHz
C _{PD}	power dissipation capacitance	V _I = GND to V _{CC} - [2] 1.5 V; V _{CC} = 5 V; f _i = 1 MHz	-	26	-	-	-	-	-	pF

[1] t_{pd} is the same as t_{PHL} and t_{PLH}.

[2] C_{PD} is used to determine the dynamic power dissipation (P_D in μW):

$$P_D = C_{PD} \times V_{CC}^2 \times f_i \times N + \sum(C_L \times V_{CC}^2 \times f_o) \text{ where:}$$

f_i = input frequency in MHz;

f_o = output frequency in MHz;

C_L = output load capacitance in pF;

V_{CC} = supply voltage in V;

N = number of inputs switching;

$\sum(C_L \times V_{CC}^2 \times f_o)$ = sum of outputs.

11. Waveforms

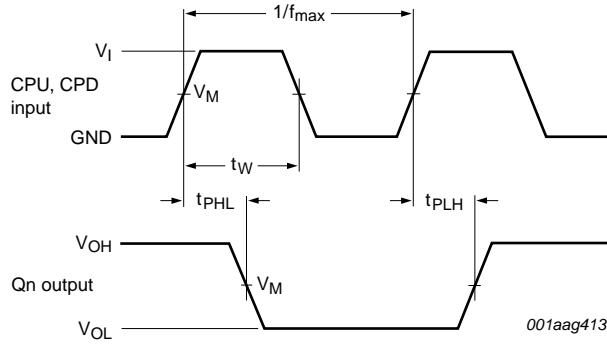

Measurement points are given in [Table 10](#).

t_{PLH} and t_{PHL} are the same as t_{pd} .

Logic levels V_{OL} and V_{OH} are typical output voltage levels that occur with the output load.

Fig 8. The clock (CPU, CPD) to output (Qn) propagation delays, the clock pulse width, and the maximum clock pulse frequency

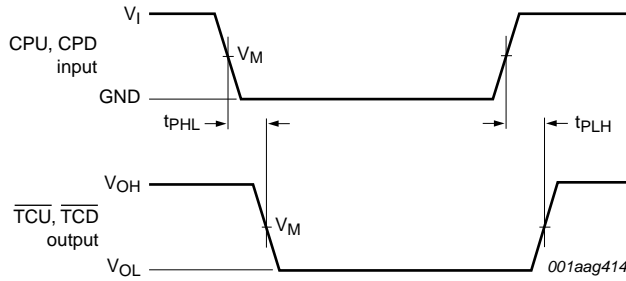

Measurement points are given in [Table 10](#).

t_{PLH} and t_{PHL} are the same as t_{pd} .

Logic levels V_{OL} and V_{OH} are typical output voltage levels that occur with the output load.

Fig 9. The clock (CPU, CPD) to terminal count output (\overline{TCU} , \overline{TCD}) propagation delays

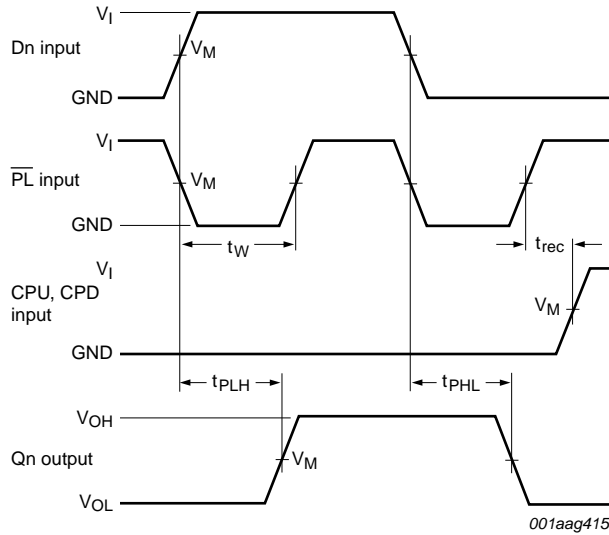

001aag415

Measurement points are given in [Table 10](#).

t_{PLH} and t_{PHL} are the same as t_{pd} .

Logic levels V_{OL} and V_{OH} are typical output voltage levels that occur with the output load.

Fig 10. The parallel load input (PL) and data (Dn) to Qn output propagation delays and PL removal time to clock input (CPU, CPD)

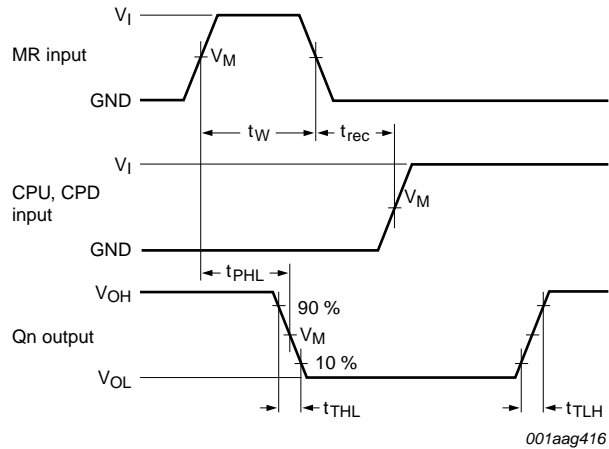

001aag416

Measurement points are given in [Table 10](#).

t_{PLH} and t_{PHL} are the same as t_{pd} .

Logic levels V_{OL} and V_{OH} are typical output voltage levels that occur with the output load.

Fig 11. The master reset input (MR) pulse width, MR to Qn propagation delays, MR to CPU, CPD removal time and output transition times

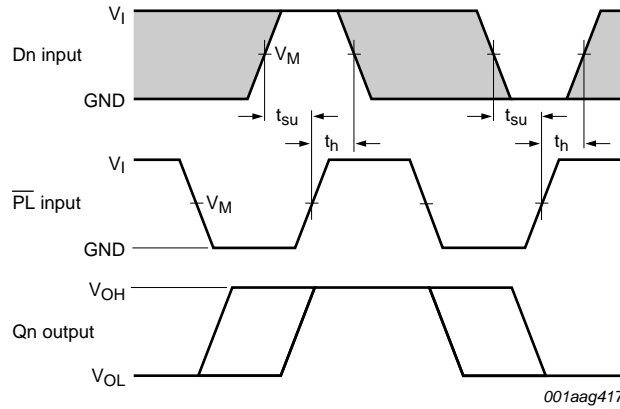

The shaded areas indicate when the input is permitted to change for predictable output performance.

Measurement points are given in [Table 10](#).

Logic levels V_{OL} and V_{OH} are typical output voltage levels that occur with the output load.

Fig 12. The data input (Dn) to parallel load input (PL) set-up and hold times

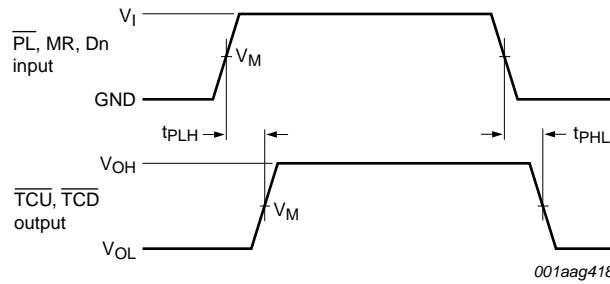

Measurement points are given in [Table 10](#).

t_{PLH} and t_{PHL} are the same as t_{pd} .

Logic levels V_{OL} and V_{OH} are typical output voltage levels that occur with the output load.

Fig 13. The data input (Dn), parallel load input (PL) and the master reset input (MR) to the terminal count outputs (TCU, TCD) propagation delays

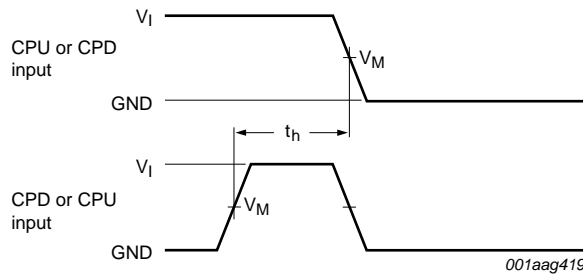

Measurement points are given in [Table 10](#).

Fig 14. The CPU to CPD or CPD to CPU hold times

Table 10. Measurement points

Type	Input		Output
	V_M	V_I	V_M
74HC193-Q100	$0.5 \times V_{CC}$	GND to V_{CC}	$0.5 \times V_{CC}$
74HCT193-Q100	1.3 V	GND to 3 V	1.3 V

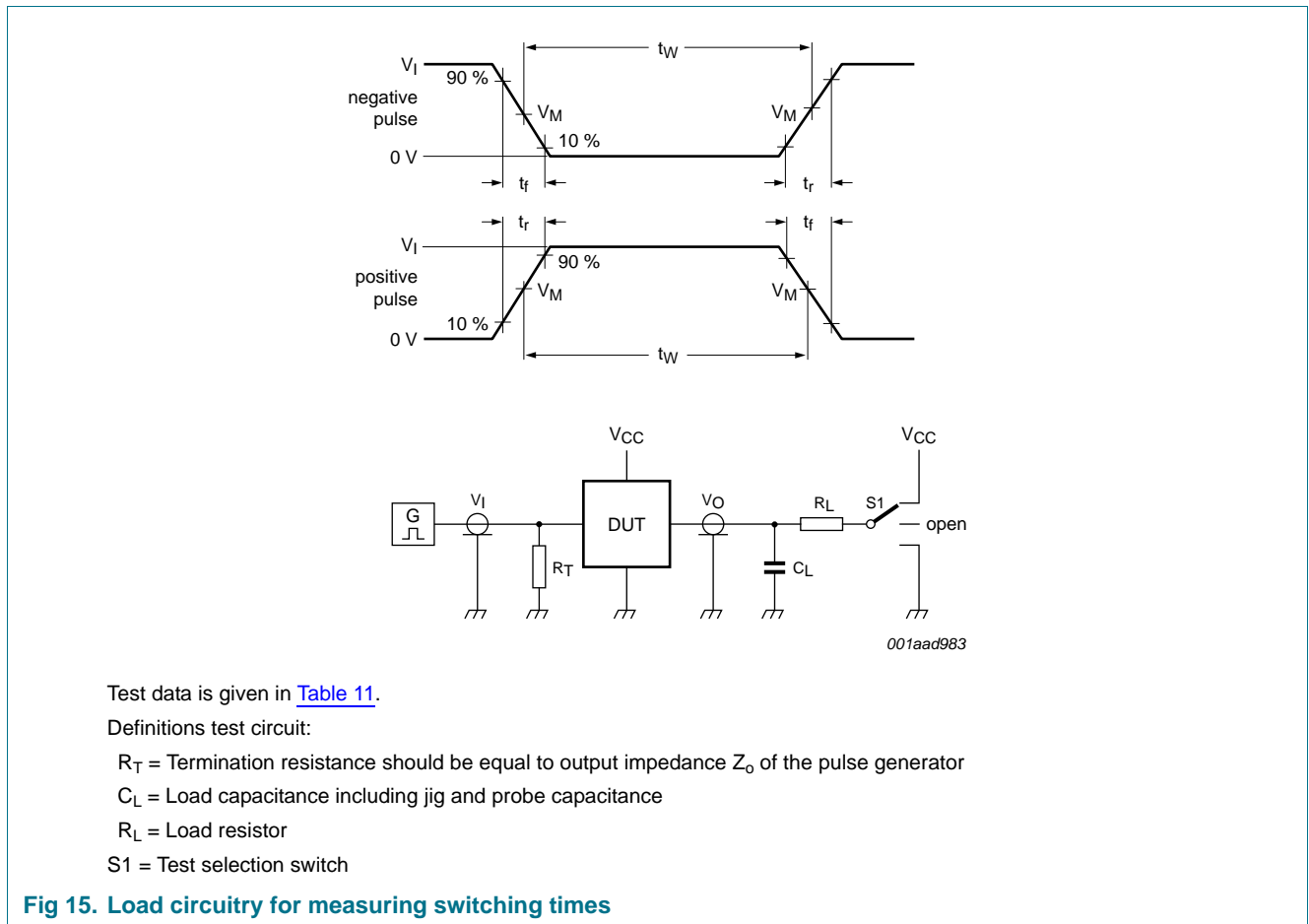

Table 11. Test data

Type	Input		Load		S1 position
	V_I	t_r, t_f	C_L	R_L	t_{PHL}, t_{PLH}
74HC193-Q100	V_{CC}	6 ns	15 pF, 50 pF	1 k Ω	open
74HCT193-Q100	3 V	6 ns	15 pF, 50 pF	1 k Ω	open

12. Application information

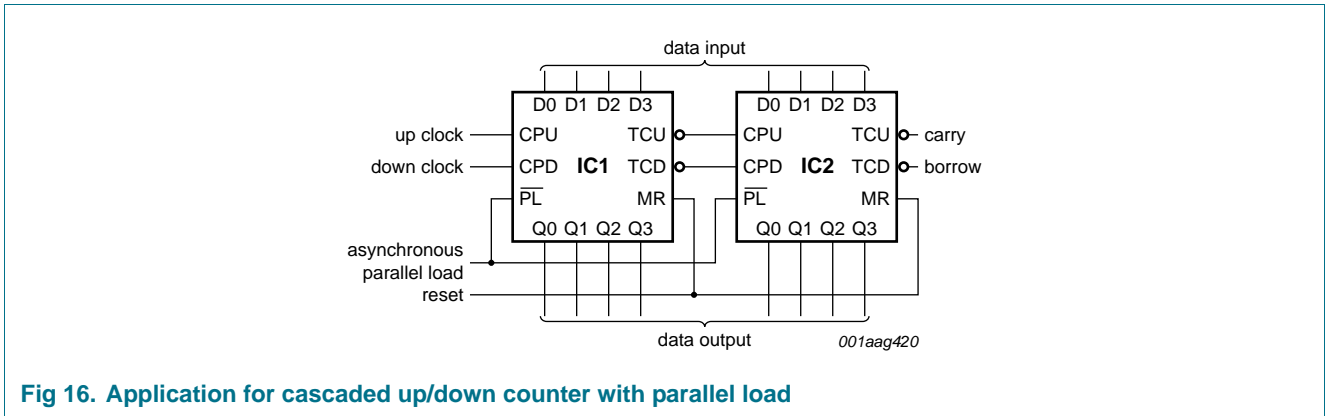

Fig 16. Application for cascaded up/down counter with parallel load

13. Package outline

SO16: plastic small outline package; 16 leads; body width 3.9 mm

SOT109-1

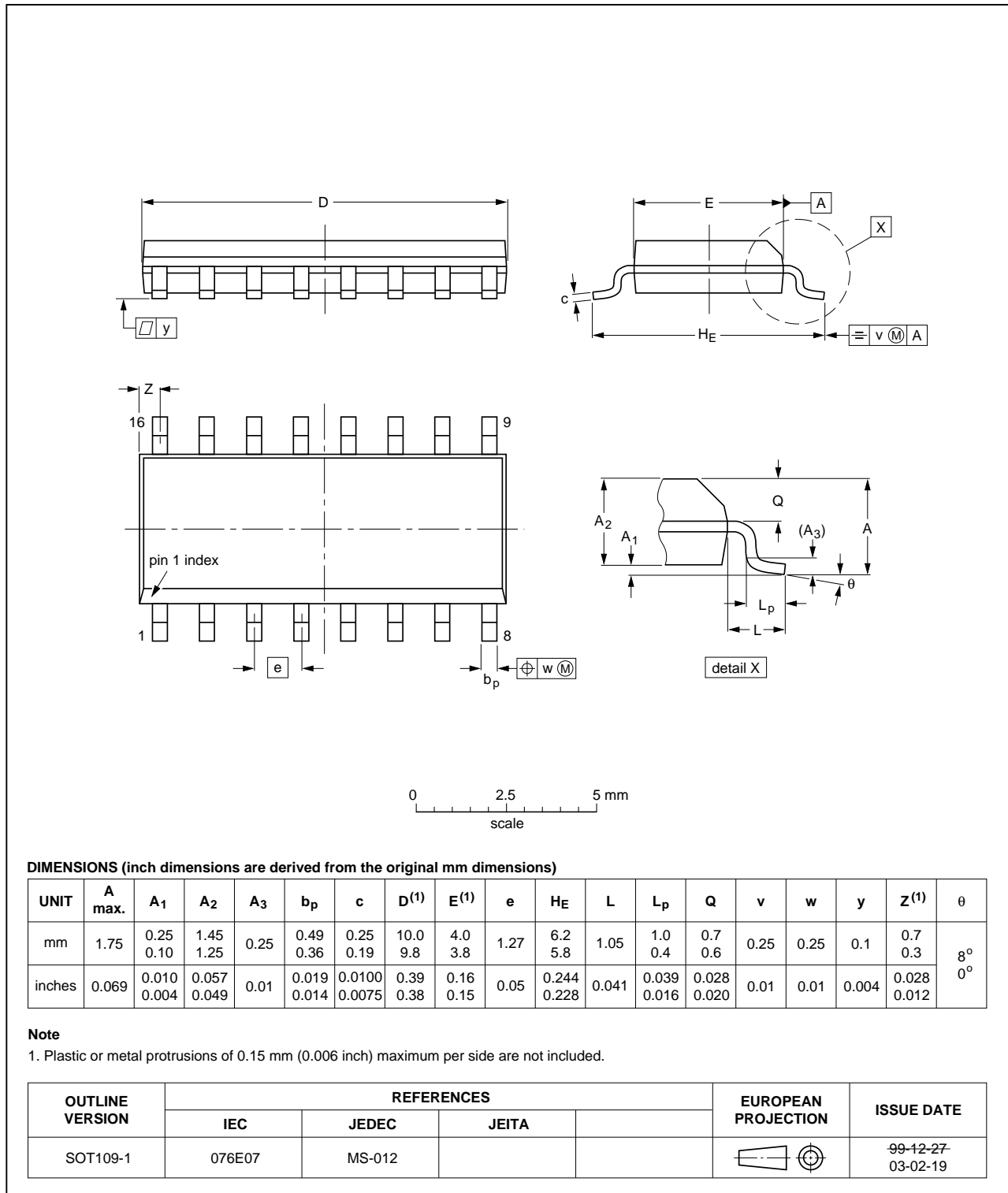

Fig 17. Package outline SOT109-1 (SO16)

SSOP16: plastic shrink small outline package; 16 leads; body width 5.3 mm

SOT338-1

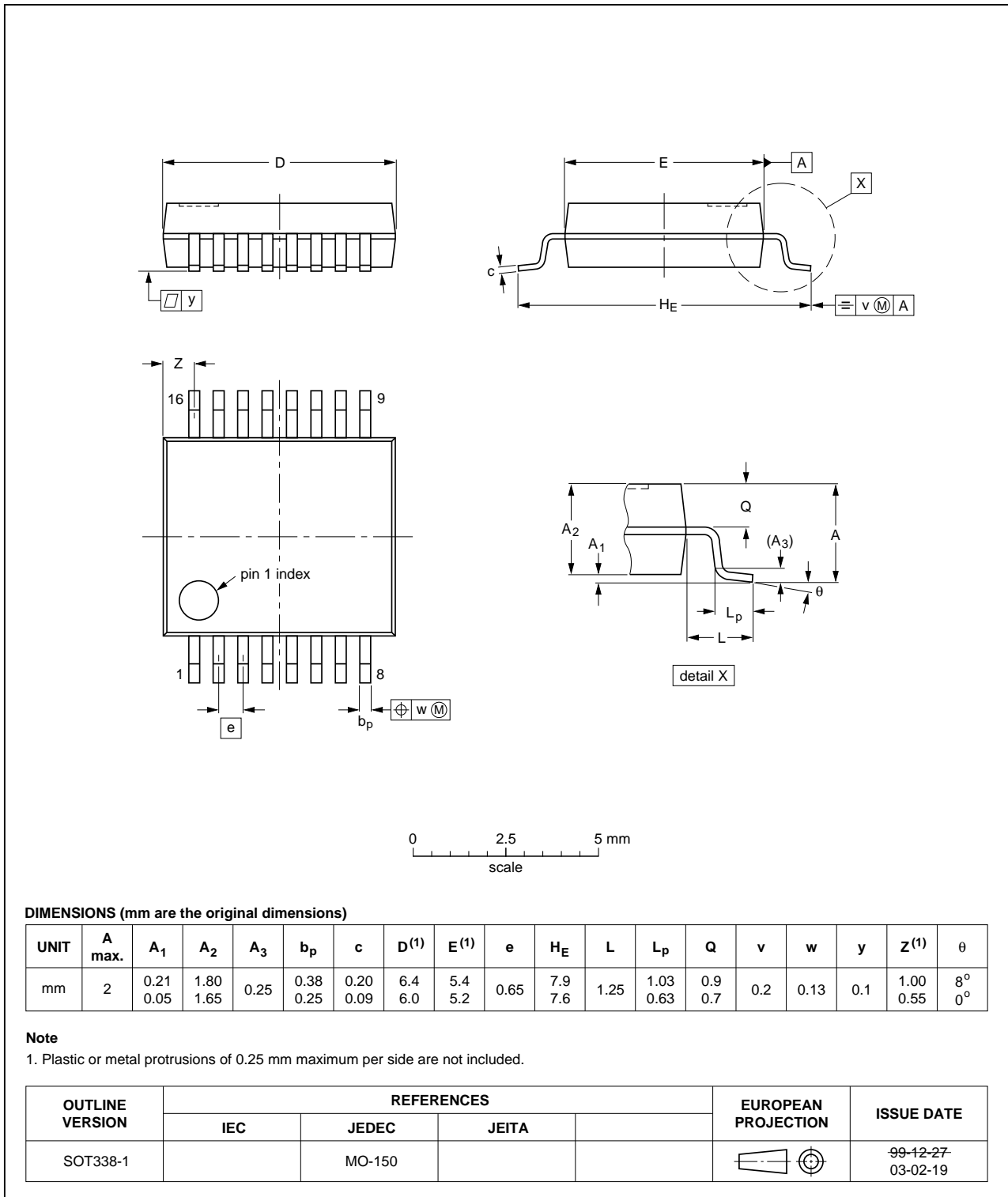

Fig 18. Package outline SOT338-1 (SSOP16)

TSSOP16: plastic thin shrink small outline package; 16 leads; body width 4.4 mm

SOT403-1

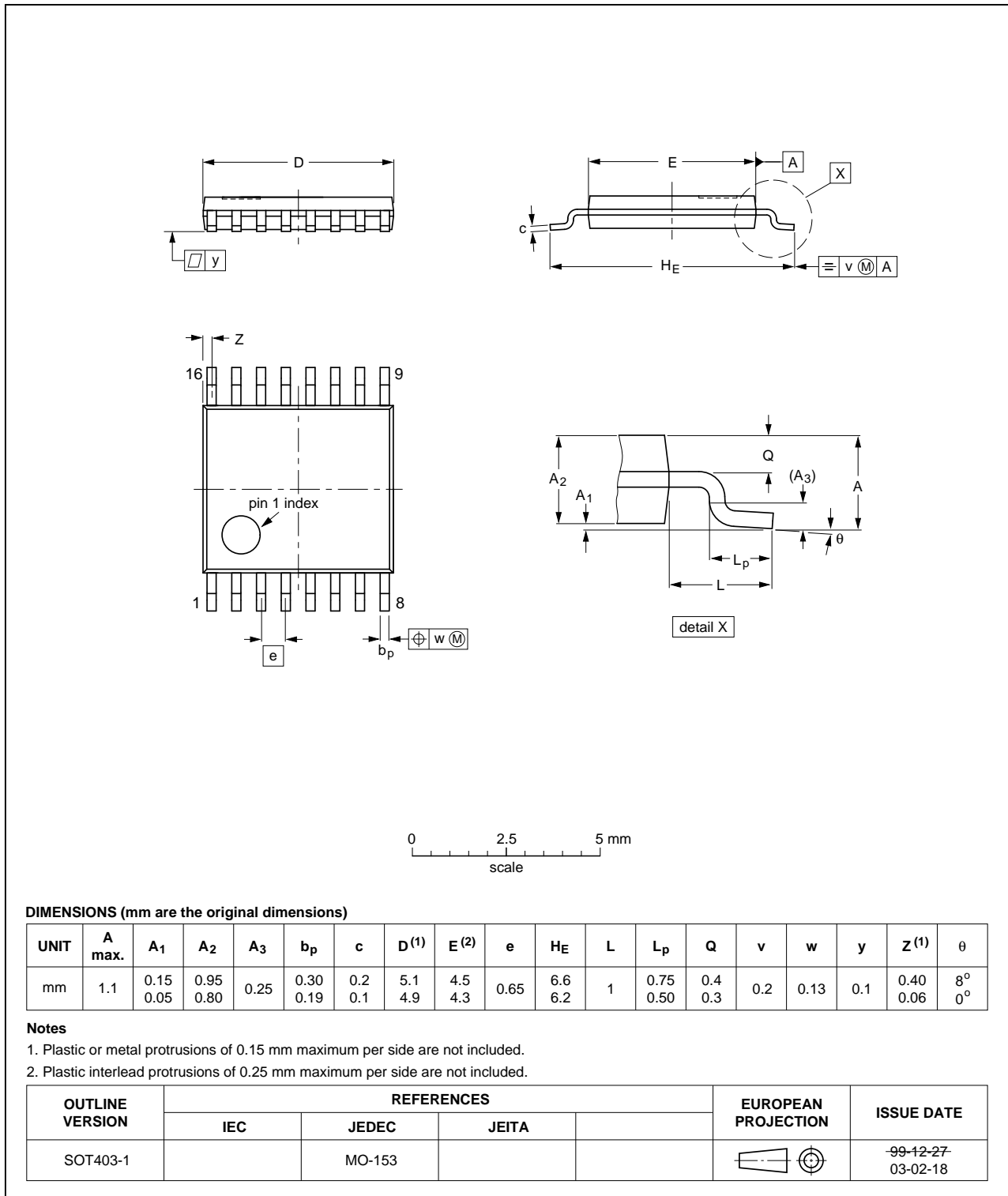

Fig 19. Package outline SOT403-1 (TSSOP16)

14. Abbreviations

Table 12. Abbreviations

Acronym	Description
CMOS	Complementary Metal-Oxide Semiconductor
DUT	Device Under Test
ESD	ElectroStatic Discharge
HBM	Human Body Model
LSTTL	Low-power Schottky Transistor-Transistor Logic
MM	Machine Model
MIL	Military
TTL	Transistor-Transistor Logic

15. Revision history

Table 13. Revision history

Document ID	Release date	Data sheet status	Change notice	Supersedes
74HC_HCT193_Q100 v.1	20130712	Product data sheet	-	-

16. Legal information

16.1 Data sheet status

Document status ^{[1][2]}	Product status ^[3]	Definition
Objective [short] data sheet	Development	This document contains data from the objective specification for product development.
Preliminary [short] data sheet	Qualification	This document contains data from the preliminary specification.
Product [short] data sheet	Production	This document contains the product specification.

[1] Please consult the most recently issued document before initiating or completing a design.

[2] The term 'short data sheet' is explained in section "Definitions".

[3] The product status of device(s) described in this document may have changed since this document was published and may differ in case of multiple devices. The latest product status information is available on the Internet at URL <http://www.nxp.com>.

16.2 Definitions

Draft — The document is a draft version only. The content is still under internal review and subject to formal approval, which may result in modifications or additions. NXP Semiconductors does not give any representations or warranties as to the accuracy or completeness of information included herein and shall have no liability for the consequences of use of such information.

Short data sheet — A short data sheet is an extract from a full data sheet with the same product type number(s) and title. A short data sheet is intended for quick reference only and should not be relied upon to contain detailed and full information. For detailed and full information see the relevant full data sheet, which is available on request via the local NXP Semiconductors sales office. In case of any inconsistency or conflict with the short data sheet, the full data sheet shall prevail.

Product specification — The information and data provided in a Product data sheet shall define the specification of the product as agreed between NXP Semiconductors and its customer, unless NXP Semiconductors and customer have explicitly agreed otherwise in writing. In no event however, shall an agreement be valid in which the NXP Semiconductors product is deemed to offer functions and qualities beyond those described in the Product data sheet.

16.3 Disclaimers

Limited warranty and liability — Information in this document is believed to be accurate and reliable. However, NXP Semiconductors does not give any representations or warranties, expressed or implied, as to the accuracy or completeness of such information and shall have no liability for the consequences of use of such information. NXP Semiconductors takes no responsibility for the content in this document if provided by an information source outside of NXP Semiconductors.

In no event shall NXP Semiconductors be liable for any indirect, incidental, punitive, special or consequential damages (including - without limitation - lost profits, lost savings, business interruption, costs related to the removal or replacement of any products or rework charges) whether or not such damages are based on tort (including negligence), warranty, breach of contract or any other legal theory.

Notwithstanding any damages that customer might incur for any reason whatsoever, NXP Semiconductors' aggregate and cumulative liability towards customer for the products described herein shall be limited in accordance with the *Terms and conditions of commercial sale* of NXP Semiconductors.

Right to make changes — NXP Semiconductors reserves the right to make changes to information published in this document, including without limitation specifications and product descriptions, at any time and without notice. This document supersedes and replaces all information supplied prior to the publication hereof.

Suitability for use in automotive applications — This NXP Semiconductors product has been qualified for use in automotive applications. Unless otherwise agreed in writing, the product is not designed, authorized or warranted to be suitable for use in life support, life-critical or safety-critical systems or equipment, nor in applications where failure or malfunction of an NXP Semiconductors product can reasonably be expected to result in personal injury, death or severe property or environmental damage. NXP Semiconductors and its suppliers accept no liability for inclusion and/or use of NXP Semiconductors products in such equipment or applications and therefore such inclusion and/or use is at the customer's own risk.

Applications — Applications that are described herein for any of these products are for illustrative purposes only. NXP Semiconductors makes no representation or warranty that such applications will be suitable for the specified use without further testing or modification.

Customers are responsible for the design and operation of their applications and products using NXP Semiconductors products, and NXP Semiconductors accepts no liability for any assistance with applications or customer product design. It is customer's sole responsibility to determine whether the NXP Semiconductors product is suitable and fit for the customer's applications and products planned, as well as for the planned application and use of customer's third party customer(s). Customers should provide appropriate design and operating safeguards to minimize the risks associated with their applications and products.

NXP Semiconductors does not accept any liability related to any default, damage, costs or problem which is based on any weakness or default in the customer's applications or products, or the application or use by customer's third party customer(s). Customer is responsible for doing all necessary testing for the customer's applications and products using NXP Semiconductors products in order to avoid a default of the applications and the products or of the application or use by customer's third party customer(s). NXP does not accept any liability in this respect.

Limiting values — Stress above one or more limiting values (as defined in the Absolute Maximum Ratings System of IEC 60134) will cause permanent damage to the device. Limiting values are stress ratings only and (proper) operation of the device at these or any other conditions above those given in the Recommended operating conditions section (if present) or the Characteristics sections of this document is not warranted. Constant or repeated exposure to limiting values will permanently and irreversibly affect the quality and reliability of the device.

Terms and conditions of commercial sale — NXP Semiconductors products are sold subject to the general terms and conditions of commercial sale, as published at <http://www.nxp.com/profile/terms>, unless otherwise agreed in a valid written individual agreement. In case an individual agreement is concluded only the terms and conditions of the respective agreement shall apply. NXP Semiconductors hereby expressly objects to applying the customer's general terms and conditions with regard to the purchase of NXP Semiconductors products by customer.

No offer to sell or license — Nothing in this document may be interpreted or construed as an offer to sell products that is open for acceptance or the grant, conveyance or implication of any license under any copyrights, patents or other industrial or intellectual property rights.

Export control — This document as well as the item(s) described herein may be subject to export control regulations. Export might require a prior authorization from competent authorities.

Translations — A non-English (translated) version of a document is for reference only. The English version shall prevail in case of any discrepancy between the translated and English versions.

16.4 Trademarks

Notice: All referenced brands, product names, service names and trademarks are the property of their respective owners.

17. Contact information

For more information, please visit: <http://www.nxp.com>

For sales office addresses, please send an email to: salesaddresses@nxp.com

18. Contents

1	General description	1
2	Features and benefits	1
3	Ordering information	2
4	Functional diagram	2
5	Pinning information	5
5.1	Pinning	5
5.2	Pin description	5
6	Functional description	6
7	Limiting values	8
8	Recommended operating conditions	8
9	Static characteristics	9
10	Dynamic characteristics	13
11	Waveforms	18
12	Application information	22
13	Package outline	23
14	Abbreviations	26
15	Revision history	26
16	Legal information	27
16.1	Data sheet status	27
16.2	Definitions	27
16.3	Disclaimers	27
16.4	Trademarks	28
17	Contact information	28
18	Contents	29

Please be aware that important notices concerning this document and the product(s) described herein, have been included in section 'Legal information'.

© NXP B.V. 2013.

All rights reserved.

For more information, please visit: <http://www.nxp.com>

For sales office addresses, please send an email to: salesaddresses@nxp.com

Date of release: 12 July 2013

Document identifier: 74HC_HCT139_Q100