

74HC590

8-bit binary counter with output register; 3-state

Rev. 02 — 28 April 2009

Product data sheet

1. General description

The 74HC590 is a high-speed Si-gate CMOS device and is pin compatible with Low power Schottky TTL (LSTTL). It is specified in compliance with JEDEC standard no. 7A.

The 74HC590 is an 8-bit binary counter with a storage register and 3-state outputs. The storage register has parallel (Q0 to Q7) outputs. The binary counter features a master reset counter (\overline{MRC}) and count enable (\overline{CE}) inputs. The counter and storage register have separate positive edge triggered clock (CPC and CPR) inputs. If both clocks are connected together, the counter state always is one count ahead of the register. Internal circuitry prevents clocking from the clock enable. A ripple carry output (\overline{RCO}) is provided for cascading. Cascading is accomplished by connecting \overline{RCO} of the first stage to \overline{CE} of the second stage. Cascading for larger count chains can be accomplished by connecting \overline{RCO} of each stage to the counter clock (CPC) input of the following stage. If both clocks are connected together, the counter state always is one count ahead of the register.

2. Features

- Counter and register have independent clock inputs
- Counter has master reset
- Complies with JEDEC standard no. 7A
- Multiple package options
- ESD protection:
 - ◆ HBM JESD22-A114E exceeds 2000 V
 - ◆ MM JESD22-A115-A exceeds 200 V
 - ◆ CDM JESD22-C101C exceeds 2000 V
- Specified from $-40\text{ }^{\circ}\text{C}$ to $+85\text{ }^{\circ}\text{C}$ and from $-40\text{ }^{\circ}\text{C}$ to $+125\text{ }^{\circ}\text{C}$

3. Ordering information

Table 1. Ordering information

Type number	Package			
	Temperature range	Name	Description	Version
74HC590N	$-40\text{ }^{\circ}\text{C}$ to $+125\text{ }^{\circ}\text{C}$	DIP16	plastic dual in-line package; 16 leads (300 mil)	SOT38-4
74HC590D	$-40\text{ }^{\circ}\text{C}$ to $+125\text{ }^{\circ}\text{C}$	SO16	plastic small outline package; 16 leads; body width 3.9 mm	SOT109-1
74HC590PW	$-40\text{ }^{\circ}\text{C}$ to $+125\text{ }^{\circ}\text{C}$	TSSOP16	plastic thin shrink small outline package; 16 leads; body width 4.4 mm	SOT403-1
74HC590BQ	$-40\text{ }^{\circ}\text{C}$ to $+125\text{ }^{\circ}\text{C}$	DHVQFN16	plastic dual in-line compatible thermal enhanced very thin quad flat package; no leads; 16 terminals; body $2.5 \times 3.5 \times 0.85\text{ mm}$	SOT763-1

4. Functional diagram

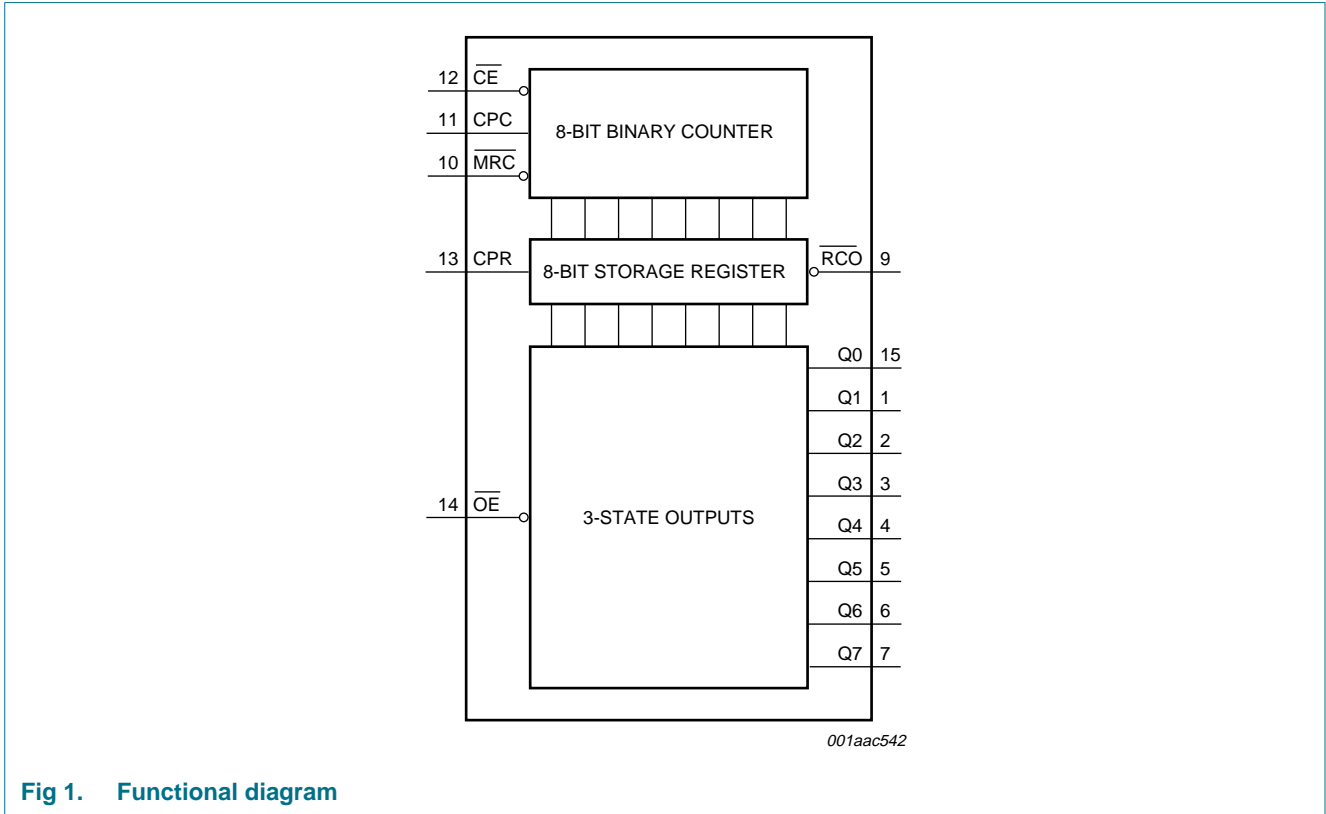

Fig 1. Functional diagram

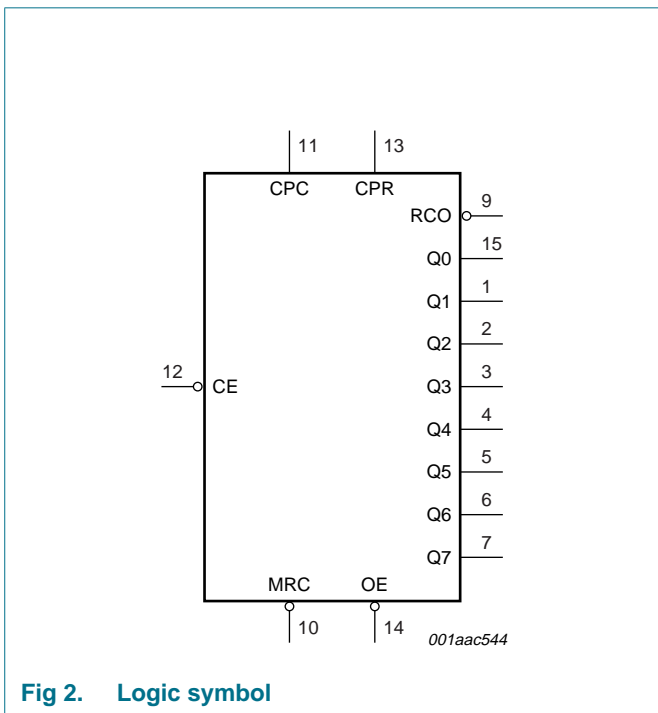

Fig 2. Logic symbol

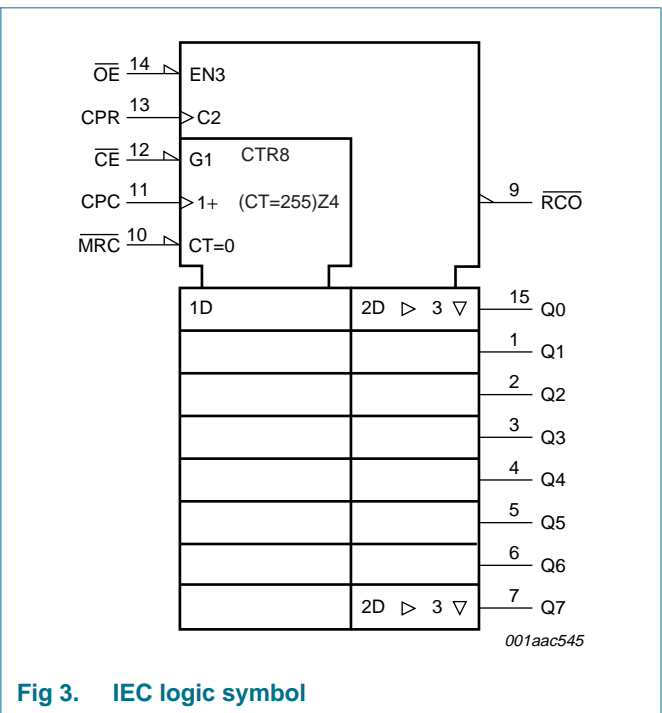
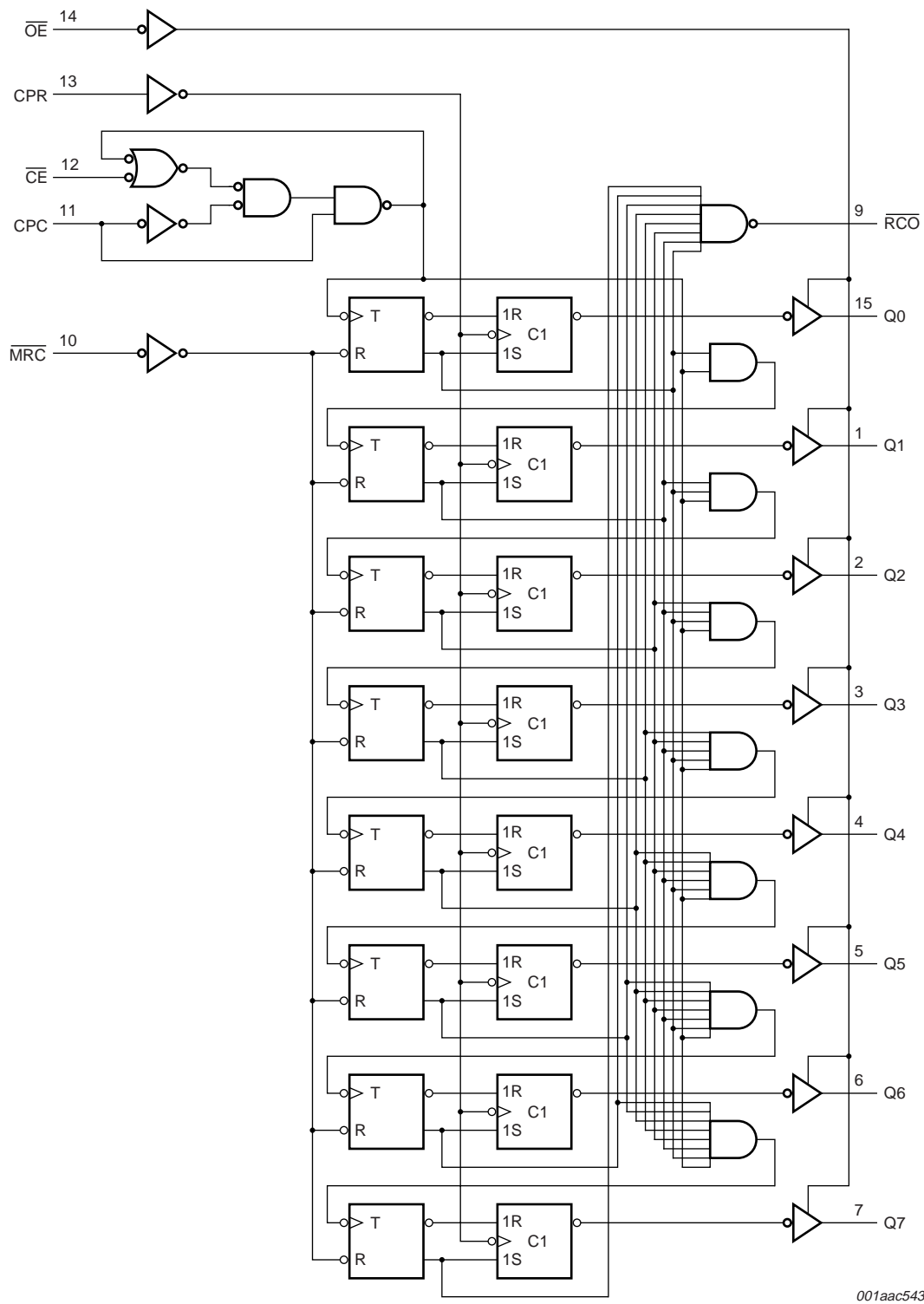

Fig 3. IEC logic symbol



001aac543

Fig 4. Logic diagram

5. Pinning information

5.1 Pinning

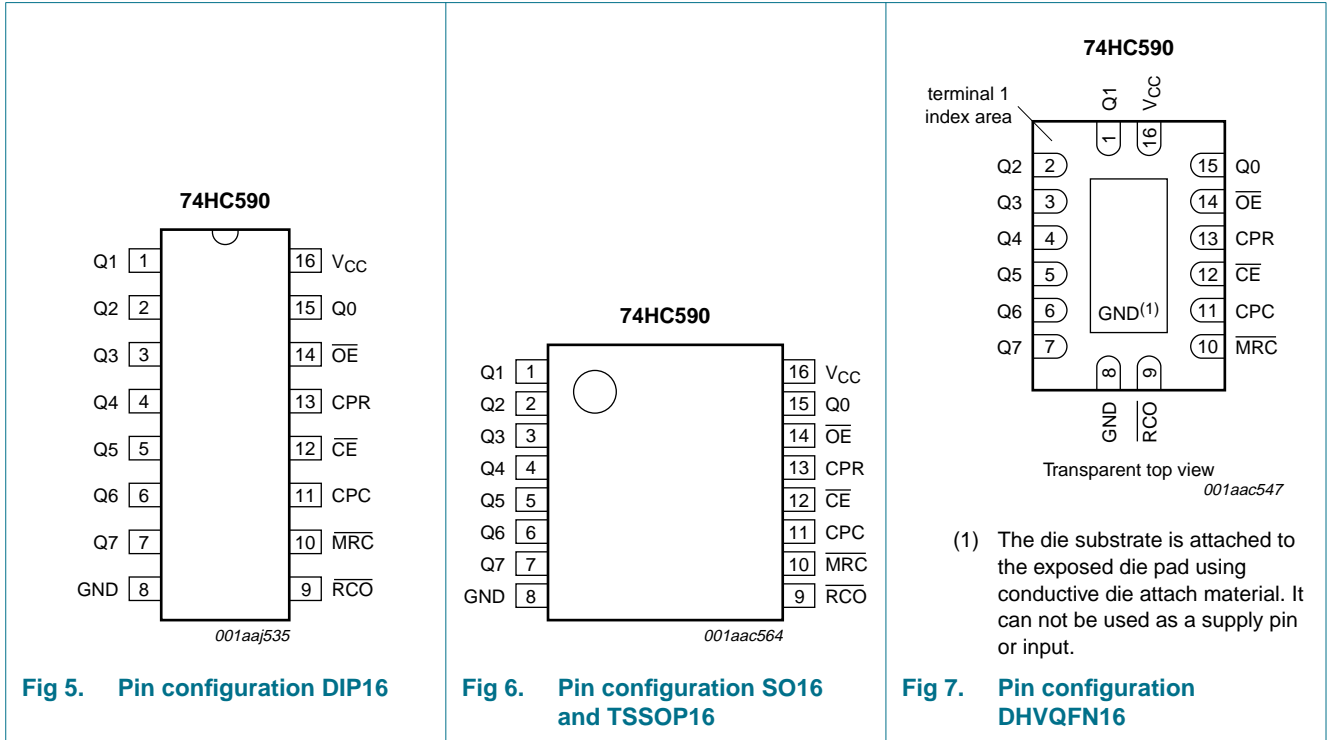

5.2 Pin description

Table 2. Pin description

Symbol	Pin	Description
Q0 to Q7	15, 1, 2, 3, 4, 5, 6, 7	parallel data output
GND	8	ground (0 V)
RCO	9	ripple carry output (active LOW)
MRC	10	master reset counter input (active LOW)
CPC	11	counter clock input (active HIGH)
CE	12	count enable input (active LOW)
CPR	13	register clock input (active HIGH)
OE	14	output enable input (active LOW)
V _{CC}	16	supply voltage

6. Functional description

Table 3. Function table^{[1] [2]}

Inputs					Description
\overline{OE}	CPR	\overline{MRC}	\overline{CE}	CPC	
H	X	X	X	X	Q outputs disable
L	X	X	X	X	Q outputs enable
X	↑	X	X	X	counter data stored into register
X	↓	X	X	X	register stage is not changed
X	X	L	X	X	counter clear
X	X	H	L	↑	advance one count
X	X	H	L	↓	no count
X	X	H	H	X	no count

- [1] H = HIGH voltage level;
 L = LOW voltage level;
 X = don't care;
 ↑ = LOW-to-HIGH transition;
 ↓ = HIGH-to-LOW transition.

- [2] $\overline{RCO} = \overline{Q0' \cdot Q1' \cdot Q2' \cdot Q3' \cdot Q4' \cdot Q5' \cdot Q6' \cdot Q7'}$ (Q0' to Q7' are internal outputs of the counter).

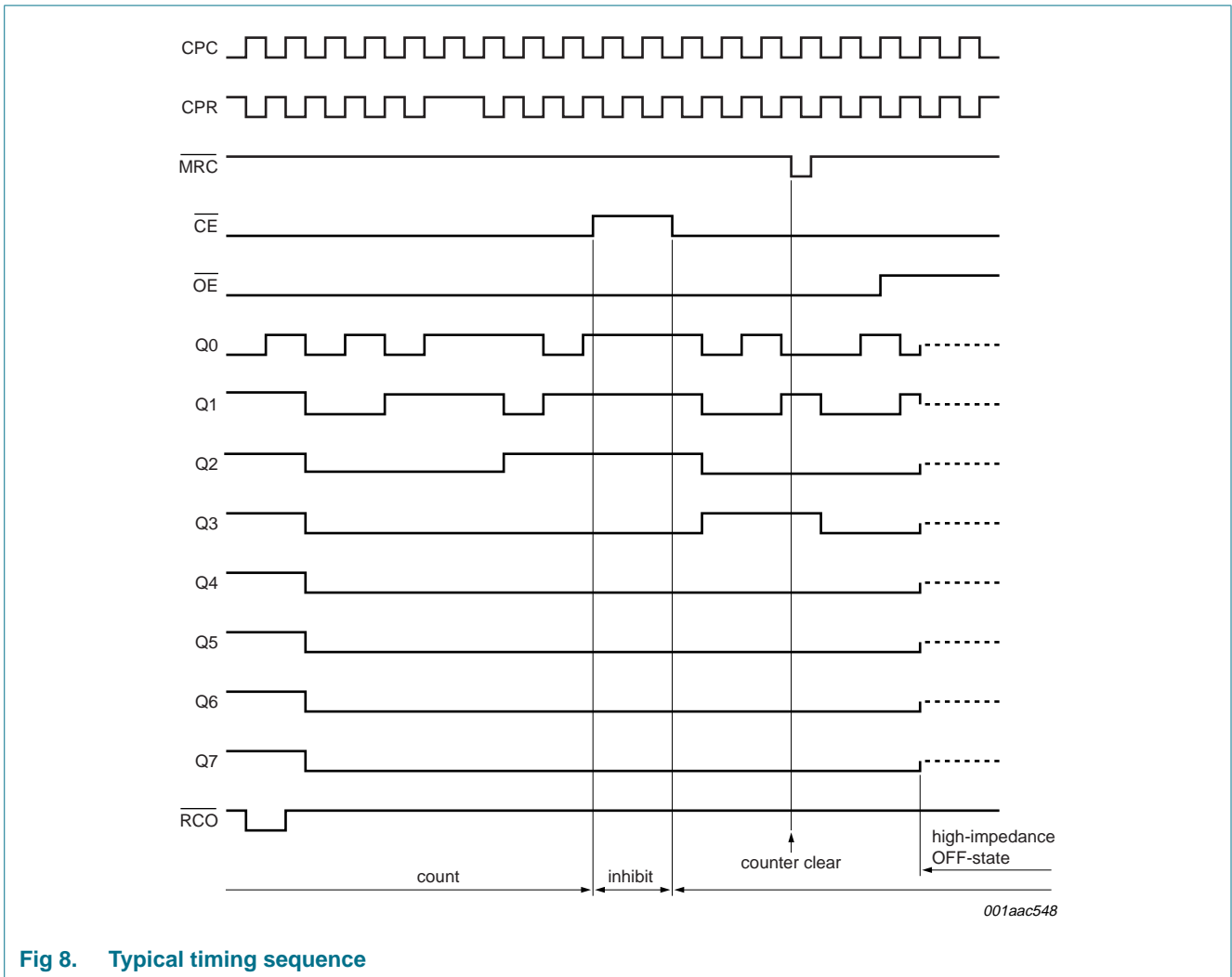

Fig 8. Typical timing sequence

7. Limiting values

Table 4. Limiting values

In accordance with the Absolute Maximum Rating System (IEC 60134). Voltages are referenced to GND (ground = 0 V).

Symbol	Parameter	Conditions	Min	Max	Unit
V_{CC}	supply voltage		-0.5	+7.0	V
I_{IK}	input clamping current	$V_I < -0.5\text{ V}$ or $V_I > V_{CC} + 0.5\text{ V}$	[1] -	±20	mA
I_{OK}	output clamping current	$V_O < -0.5\text{ V}$ or $V_O > V_{CC} + 0.5\text{ V}$	[1] -	±20	mA
I_O	output current	$V_O = -0.5\text{ V}$ to $V_{CC} + 0.5\text{ V}$			
		R \overline{CO} standard output	-	±25	mA
		Qn bus driver output	-	±35	mA
I_{CC}	supply current		-	70	mA
I_{GND}	ground current		-70	-	mA
T_{stg}	storage temperature		-65	+150	°C
P_{tot}	total power dissipation	$T_{amb} = -40\text{ °C}$ to $+125\text{ °C}$	[2]		
		DIP16 package	-	750	mW
		SO16 package	-	500	mW
		TSSOP16 package	-	500	mW

[1] The input and output voltage ratings may be exceeded if the input and output current ratings are observed.

[2] For DIP16 package: P_{tot} derates linearly with 12 mW/K above 70 °C.
 For SO16 packages: P_{tot} derates linearly with 8 mW/K above 70 °C.
 For TSSOP16 packages: P_{tot} derates linearly with 5.5 mW/K above 60 °C.
 For DHVQFN16 packages: P_{tot} derates linearly with 8 mW/K above 60 °C.

8. Recommended operating conditions

Table 5. Recommended operating conditions

Symbol	Parameter	Conditions	Min	Typ	Max	Unit
V_{CC}	supply voltage		2.0	5.0	6.0	V
V_I	input voltage		0	-	V_{CC}	V
V_O	output voltage		0	-	V_{CC}	V
$\Delta t/\Delta V$	input transition rise and fall rate	$V_{CC} = 2.0\text{ V}$	-	-	625	ns/V
		$V_{CC} = 4.5\text{ V}$	-	1.67	139	ns/V
		$V_{CC} = 6.0\text{ V}$	-	-	83	ns/V
T_{amb}	ambient temperature		-40	-	+125	°C

9. Static characteristics

Table 6. Static characteristics

At recommended operating conditions; voltages are referenced to GND (ground = 0 V).

Symbol	Parameter	Conditions	25 °C			-40 °C to +85 °C		-40 °C to +125 °C		Unit
			Min	Typ	Max	Min	Max	Min	Max	
V _{IH}	HIGH-level input voltage	V _{CC} = 2.0 V	1.5	1.2	-	1.5	-	1.5	-	V
		V _{CC} = 4.5 V	3.15	2.4	-	3.15	-	3.15	-	V
		V _{CC} = 6.0 V	4.2	3.2	-	4.2	-	4.2	-	V
V _{IL}	LOW-level input voltage	V _{CC} = 2.0 V	-	0.8	0.5	-	0.5	-	0.5	V
		V _{CC} = 4.5 V	-	2.1	1.35	-	1.35	-	1.35	V
		V _{CC} = 6.0 V	-	2.8	1.8	-	1.8	-	1.8	V
V _{OH}	HIGH-level output voltage	V _I = V _{IH} or V _{IL} all outputs								
		I _O = -20 μA; V _{CC} = 2.0 V	1.9	2.0	-	1.9	-	1.9	-	V
		I _O = -20 μA; V _{CC} = 4.5 V	4.4	4.5	-	4.4	-	4.4	-	V
		I _O = -20 μA; V _{CC} = 6.0 V	5.9	6.0	-	5.9	-	5.9	-	V
		$\overline{\text{RCO}}$ standard output								
		I _O = -4 mA; V _{CC} = 4.5 V	4.18	4.31	-	4.13	-	4.1	-	V
		I _O = -5.2 mA; V _{CC} = 6.0 V	5.68	5.80	-	5.63	-	5.6	-	V
		Qn bus driver output								
		I _O = -6.0 mA; V _{CC} = 4.5 V	4.18	4.31	-	4.13	-	4.1	-	V
I _O = -7.8 mA; V _{CC} = 6.0 V	5.68	5.80	-	5.63	-	5.6	-	V		
V _{OL}	LOW-level output voltage	V _I = V _{IH} or V _{IL} all outputs								
		I _O = 20 μA; V _{CC} = 2.0 V	-	0	0.1	-	0.1	-	0.1	V
		I _O = 20 μA; V _{CC} = 4.5 V	-	0	0.1	-	0.1	-	0.1	V
		I _O = 20 μA; V _{CC} = 6.0 V	-	0	0.1	-	0.1	-	0.1	V
		$\overline{\text{RCO}}$ standard output								
		I _O = 4 mA; V _{CC} = 4.5 V	-	0.17	0.26	-	0.33	-	0.4	V
		I _O = 5.2 mA; V _{CC} = 6.0 V	-	0.18	0.26	-	0.33	-	0.4	V
		Qn bus driver output								
		I _O = 6.0 mA; V _{CC} = 4.5 V	-	0.17	0.26	-	0.33	-	0.4	V
I _O = 7.8 mA; V _{CC} = 6.0 V	-	0.18	0.26	-	0.33	-	0.4	V		
I _I	input leakage current	V _I = V _{CC} or GND; V _{CC} = 6.0 V	-	-	±0.1	-	±1.0	-	±1.0	μA
I _{OZ}	OFF-state output current	per pin; V _I = V _{IH} or V _{IL} ; V _O = V _{CC} or GND; other inputs at V _{CC} or GND; V _{CC} = 6.0 V	-	-	±0.5	-	±5.0	-	±10	μA
I _{CC}	supply current	V _I = V _{CC} or GND; I _O = 0 A; V _{CC} = 6.0 V	-	-	4.0	-	40	-	80	μA
C _I	input capacitance		-	3.5	-	-	-	-	-	pF

10. Dynamic characteristics

Table 7. Dynamic characteristics
GND (ground = 0 V); for test circuit see Figure 15.

Symbol	Parameter	Conditions	25 °C			-40 °C to +85 °C		-40 °C to +125 °C		Unit	
			Min	Typ	Max	Min	Max	Min	Max		
t _{pd}	propagation delay	CPC to RCO; see Figure 9 ^[1]									
		V _{CC} = 2.0 V	-	52	150	-	190	-	230	ns	
		V _{CC} = 4.5 V	-	19	30	-	38	-	45	ns	
		V _{CC} = 6.0 V	-	15	26	-	33	-	40	ns	
		CPR to Qn; see Figure 10									
		V _{CC} = 2.0 V	-	50	140	-	175	-	210	ns	
t _{PLH}	LOW to HIGH propagation delay	MRC to RCO; see Figure 11									
		V _{CC} = 2.0 V	-	53	130	-	165	-	200	ns	
		V _{CC} = 4.5 V	-	18	26	-	33	-	40	ns	
t _{en}	enable time	V _{CC} = 6.0 V	-	14	22	-	28	-	34	ns	
		OE to Qn; see Figure 12 ^[2]									
		V _{CC} = 2.0 V	-	28	105	-	130	-	160	ns	
t _{dis}	disable time	V _{CC} = 4.5 V	-	13	21	-	26	-	32	ns	
		V _{CC} = 6.0 V	-	11	18	-	22	-	27	ns	
		OE to Qn; see Figure 12 ^[3]									
t _w	pulse width	V _{CC} = 2.0 V	-	28	105	-	130	-	160	ns	
		V _{CC} = 4.5 V	-	13	21	-	26	-	32	ns	
		V _{CC} = 6.0 V	-	11	18	-	22	-	27	ns	
		CPC and CPR; HIGH or LOW; see Figure 9 and Figure 10									
		V _{CC} = 2.0 V	100	24	-	125	-	145	-	ns	
		V _{CC} = 4.5 V	20	9	-	25	-	29	-	ns	
		V _{CC} = 6.0 V	17	8	-	21	-	25	-	ns	
		MRC; LOW; see Figure 11									
		V _{CC} = 2.0 V	75	28	-	95	-	110	-	ns	
V _{CC} = 4.5 V	15	8	-	19	-	22	-	ns			
V _{CC} = 6.0 V	13	6	-	16	-	19	-	ns			
t _{su}	set-up time	CPC to CPR; see Figure 14									
		V _{CC} = 2.0 V	100	46	-	125	-	150	-	ns	
		V _{CC} = 4.5 V	20	14	-	25	-	30	-	ns	
		V _{CC} = 6.0 V	17	10	-	21	-	26	-	ns	
		CE to CPC; see Figure 13									
		V _{CC} = 2.0 V	100	44	-	125	-	150	-	ns	
		V _{CC} = 4.5 V	20	11	-	25	-	30	-	ns	
		V _{CC} = 6.0 V	17	9	-	21	-	26	-	ns	

Table 7. Dynamic characteristics ...continued
 GND (ground = 0 V); for test circuit see [Figure 15](#).

Symbol	Parameter	Conditions	25 °C			-40 °C to +85 °C		-40 °C to +125 °C		Unit
			Min	Typ	Max	Min	Max	Min	Max	
t _h	hold time	CE̅ to CPC; see Figure 13								
		V _{CC} = 2.0 V	0	-	-	0	-	0	-	ns
		V _{CC} = 4.5 V	0	-	-	0	-	0	-	ns
		V _{CC} = 6.0 V	0	-	-	0	-	0	-	ns
t _{rec}	recovery time	MRC̅ to CPC; see Figure 11								
		V _{CC} = 2.0 V	75	28	-	95	-	110	-	ns
		V _{CC} = 4.5 V	15	7	-	19	-	22	-	ns
		V _{CC} = 6.0 V	13	6	-	16	-	19	-	ns
f _{max}	maximum frequency	CPC or CPR; see Figure 9 and Figure 10								
		V _{CC} = 2.0 V	6.6	16	-	5.2	-	4.4	-	MHz
		V _{CC} = 4.5 V	33	52	-	26	-	22	-	MHz
		V _{CC} = 6.0 V	39	61	-	31	-	26	-	MHz
C _{PD}	power dissipation capacitance	V _I = GND to V _{CC}	[4]	-	44	-	-	-	-	pF

[1] t_{pd} is the same as t_{PHL}, t_{PLH}.

[2] t_{en} is the same as t_{PZH} and t_{PZL}.

[3] t_{dis} is the same as t_{PLZ} and t_{PHZ}.

[4] C_{PD} is used to determine the dynamic power dissipation (P_D in μW).

$$P_D = C_{PD} \times V_{CC}^2 \times f_i \times N + \sum(C_L \times V_{CC}^2 \times f_o) \text{ where:}$$

f_i = input frequency in MHz;

f_o = output frequency in MHz;

C_L = output load capacitance in pF;

V_{CC} = supply voltage in V;

N = number of inputs switching;

∑(C_L × V_{CC}² × f_o) = sum of outputs.

11. Waveforms

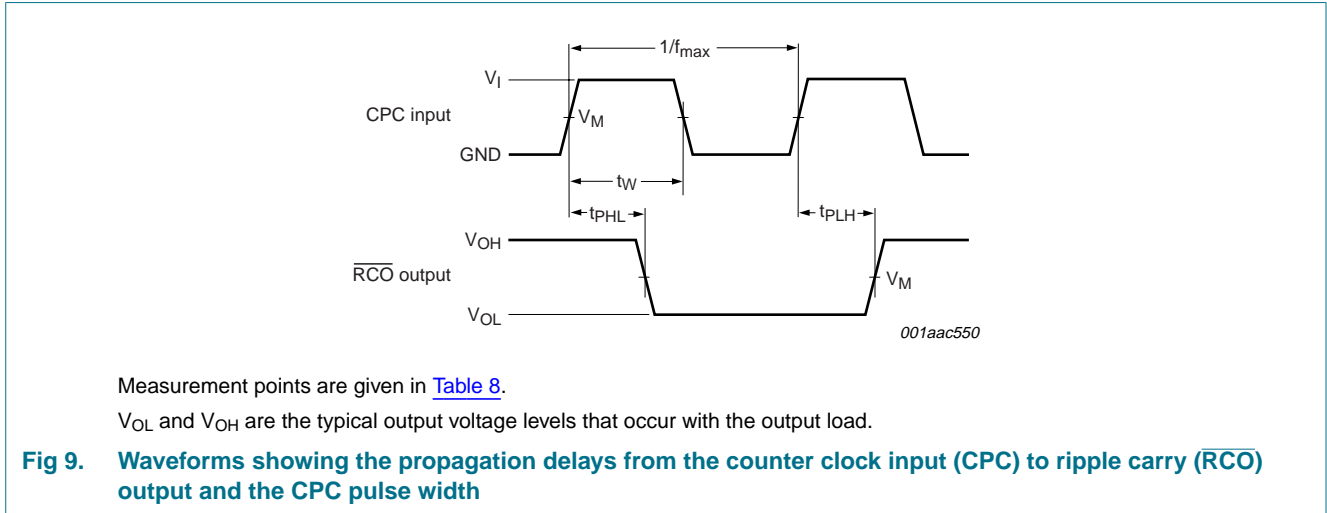
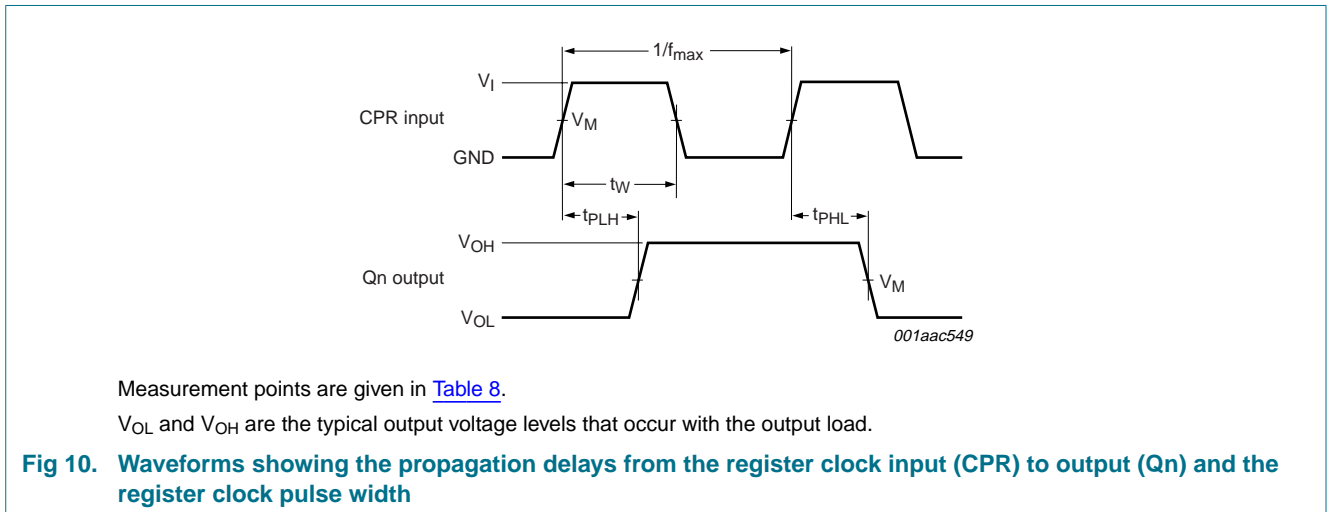
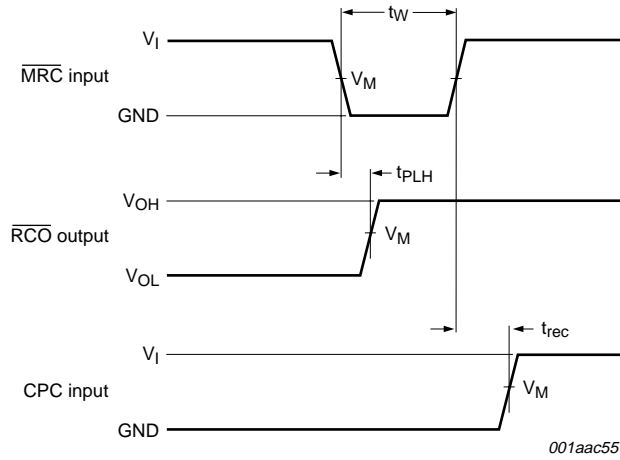

Table 8. Measurement points

Type	Input		Output
	V_I	V_M	V_M
74HC590	V_{CC}	$0.5V_{CC}$	$0.5V_{CC}$





Measurement points are given in [Table 8](#).

V_{OL} and V_{OH} are the typical output voltage levels that occur with the output load.

Fig 11. Waveforms showing the propagation delays from the master reset counter input (\overline{MRC}) to output (\overline{RCO}), the MRC pulse width and recovery time

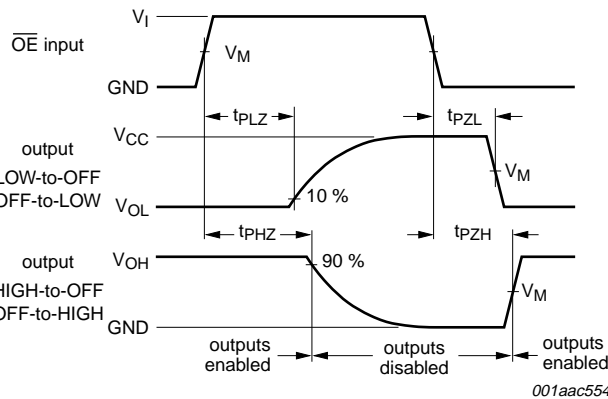

Measurement points are given in [Table 8](#).

V_{OL} and V_{OH} are the typical output voltage levels that occur with the output load.

Fig 12. Waveforms showing the 3-state enable and disable times

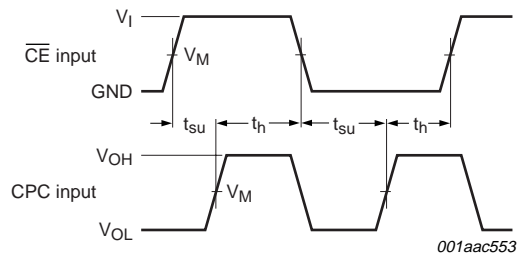

Measurement points are given in [Table 8](#).
 V_{OL} and V_{OH} are the typical output voltage levels that occur with the output load.

Fig 13. Waveforms showing the set-up and hold times for the count enable input (\overline{CE}) to the counter clock input (CPC)

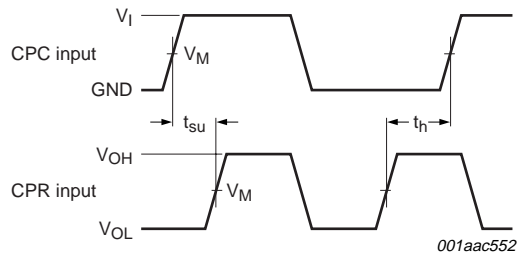

Measurement points are given in [Table 8](#).
 V_{OL} and V_{OH} are the typical output voltage levels that occur with the output load.

Fig 14. Waveforms showing the set-up and hold times for the counter clock input (CPC) to the register clock input (CPR)

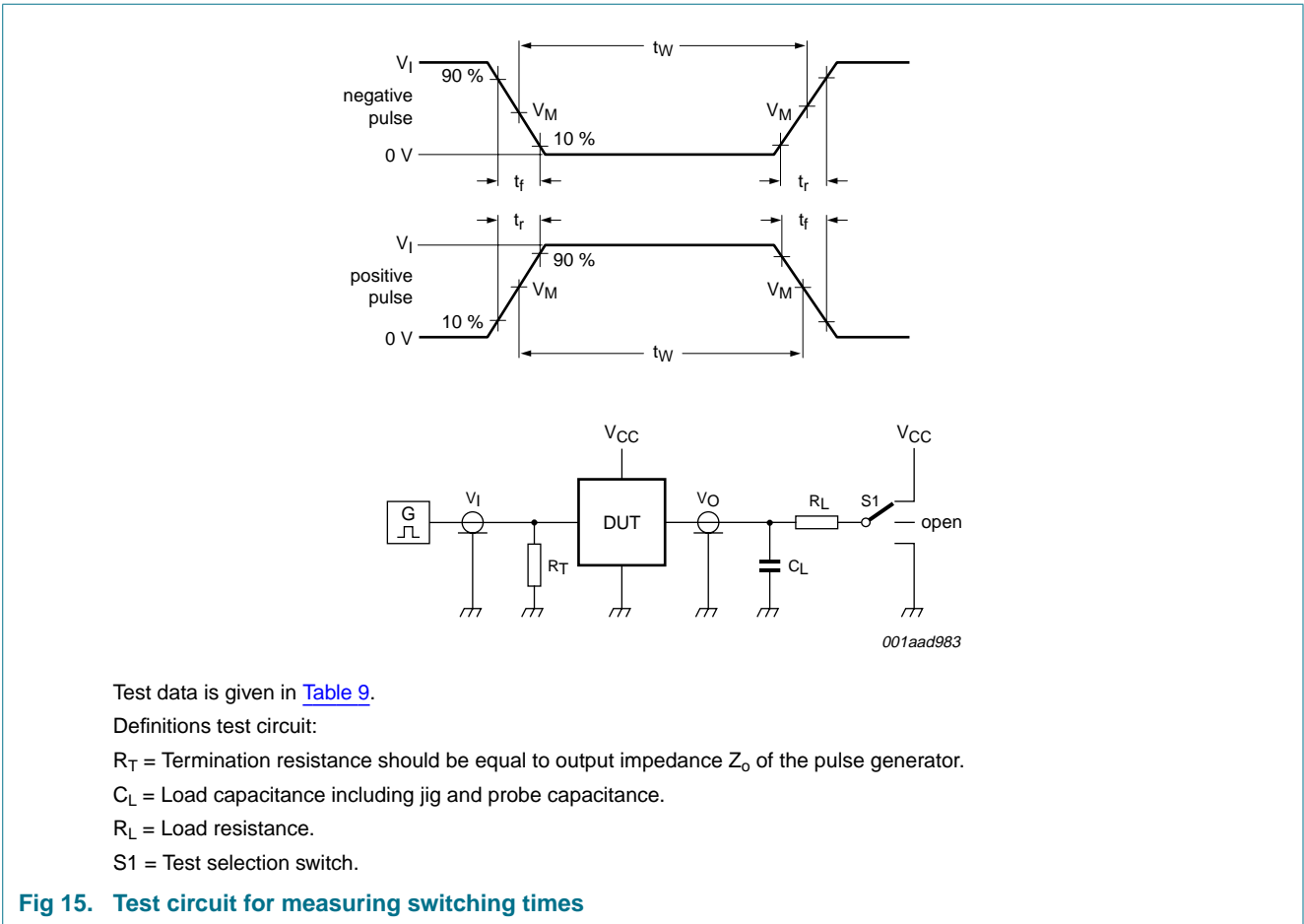

Test data is given in [Table 9](#).

Definitions test circuit:

R_T = Termination resistance should be equal to output impedance Z_o of the pulse generator.

C_L = Load capacitance including jig and probe capacitance.

R_L = Load resistance.

S1 = Test selection switch.

Fig 15. Test circuit for measuring switching times

Table 9. Test data

Supply voltage	Input		Load		Switch position		
V_{CC}	V_I	t_r, t_f	C_L	R_L	t_{PHL}, t_{PLH}	t_{PZH}, t_{PHZ}	t_{PZL}, t_{PLZ}
2.0 V to 6.0 V	V_{CC}	6 ns	50 pF	1 k Ω	open	GND	V_{CC}

12. Package outline

DIP16: plastic dual in-line package; 16 leads (300 mil)

SOT38-4

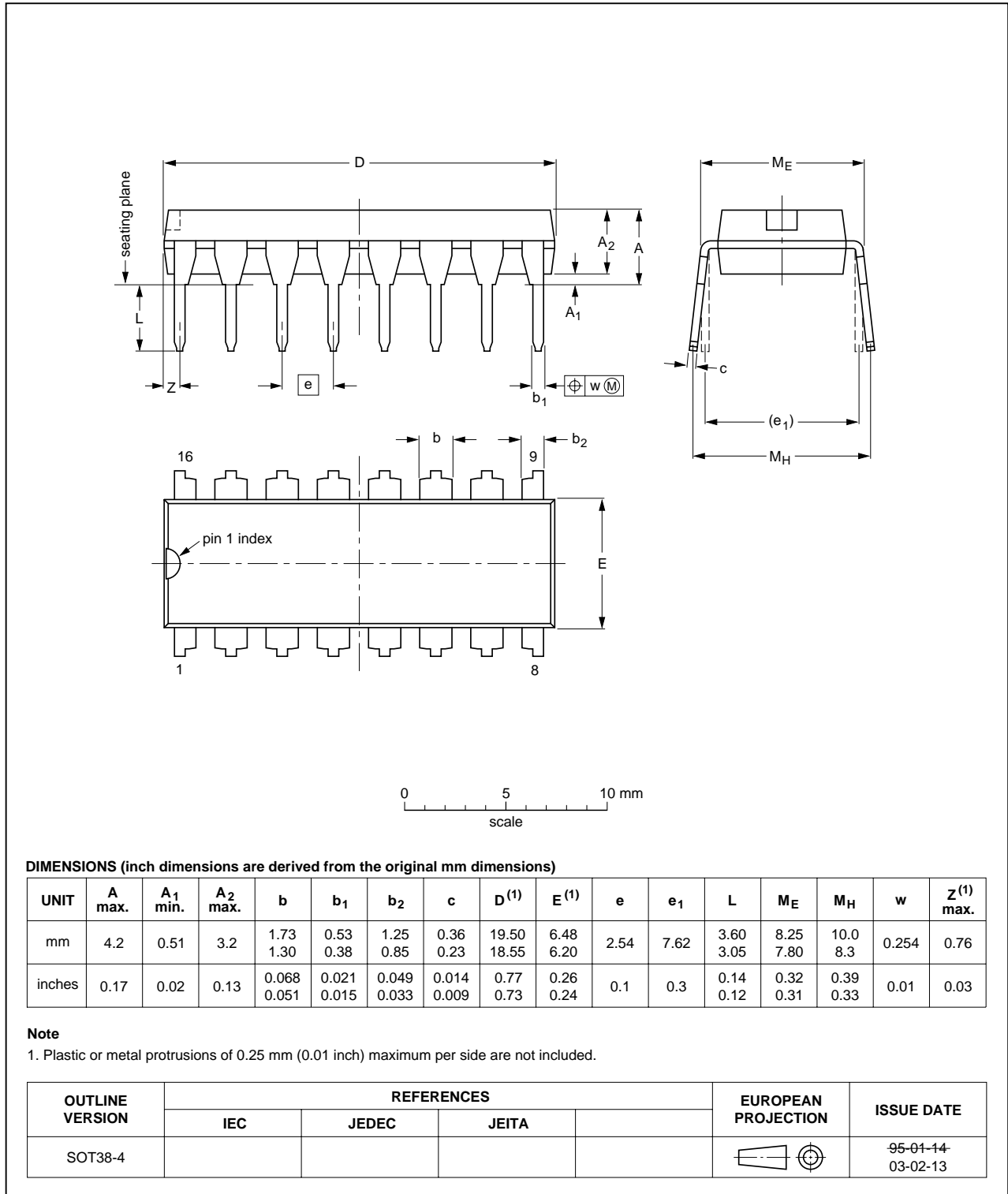

Fig 16. Package outline SOT38-4 (DIP16)

SO16: plastic small outline package; 16 leads; body width 3.9 mm

SOT109-1

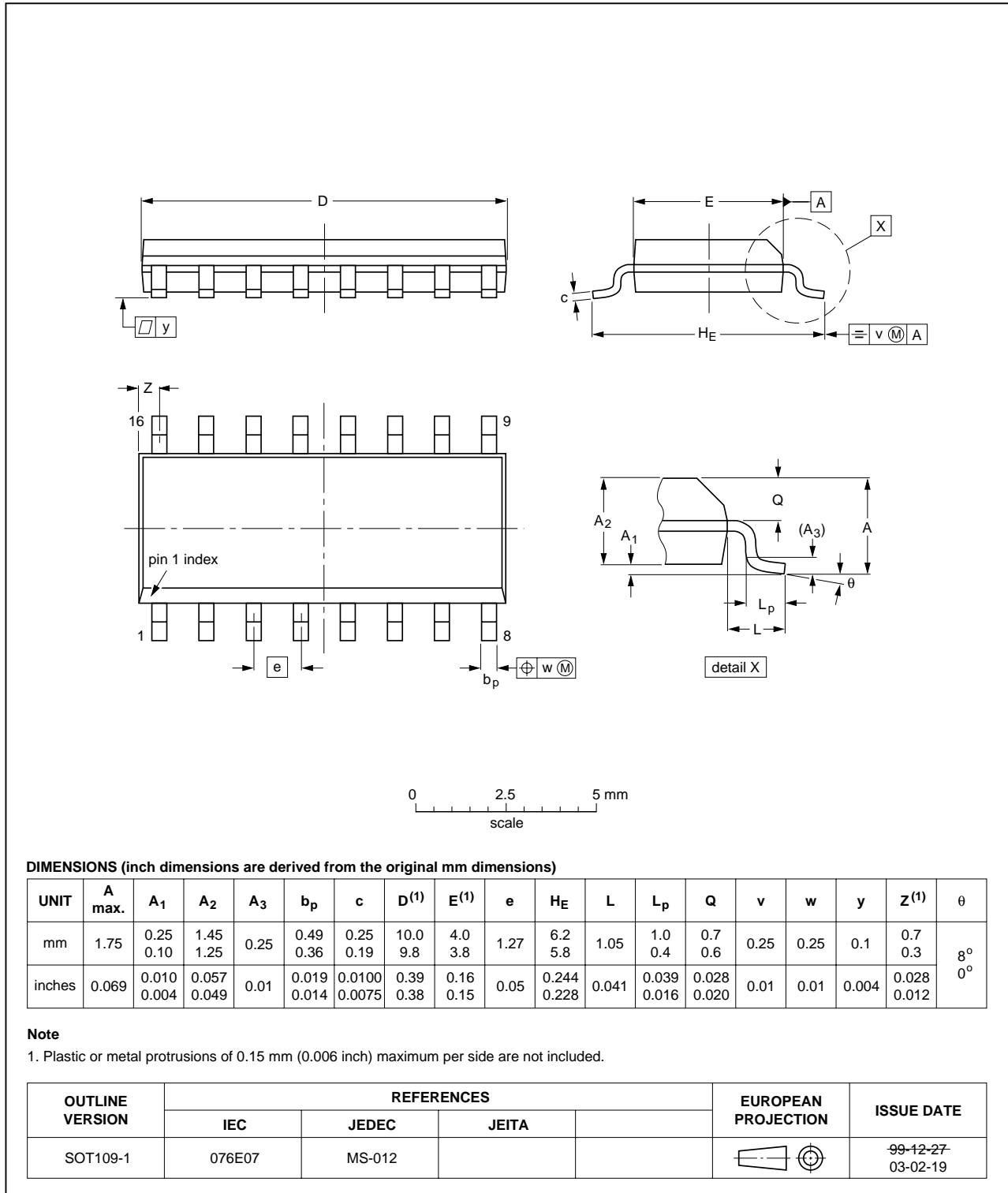

Fig 17. Package outline SOT109-1 (SO16)

TSSOP16: plastic thin shrink small outline package; 16 leads; body width 4.4 mm

SOT403-1

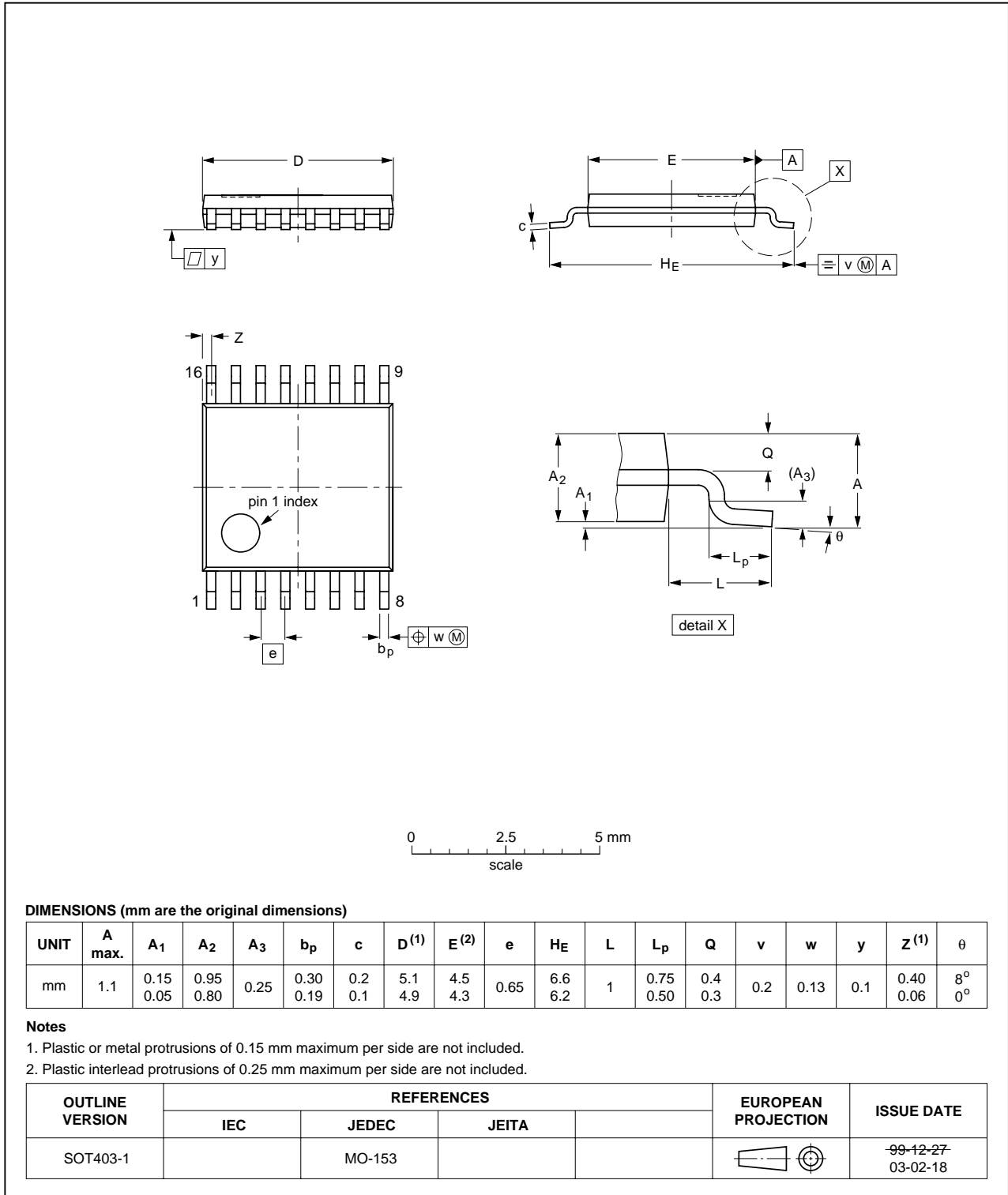

Fig 18. Package outline SOT403-1 (TSSOP16)

DHVQFN16: plastic dual in-line compatible thermal enhanced very thin quad flat package; no leads; 16 terminals; body 2.5 x 3.5 x 0.85 mm

SOT763-1

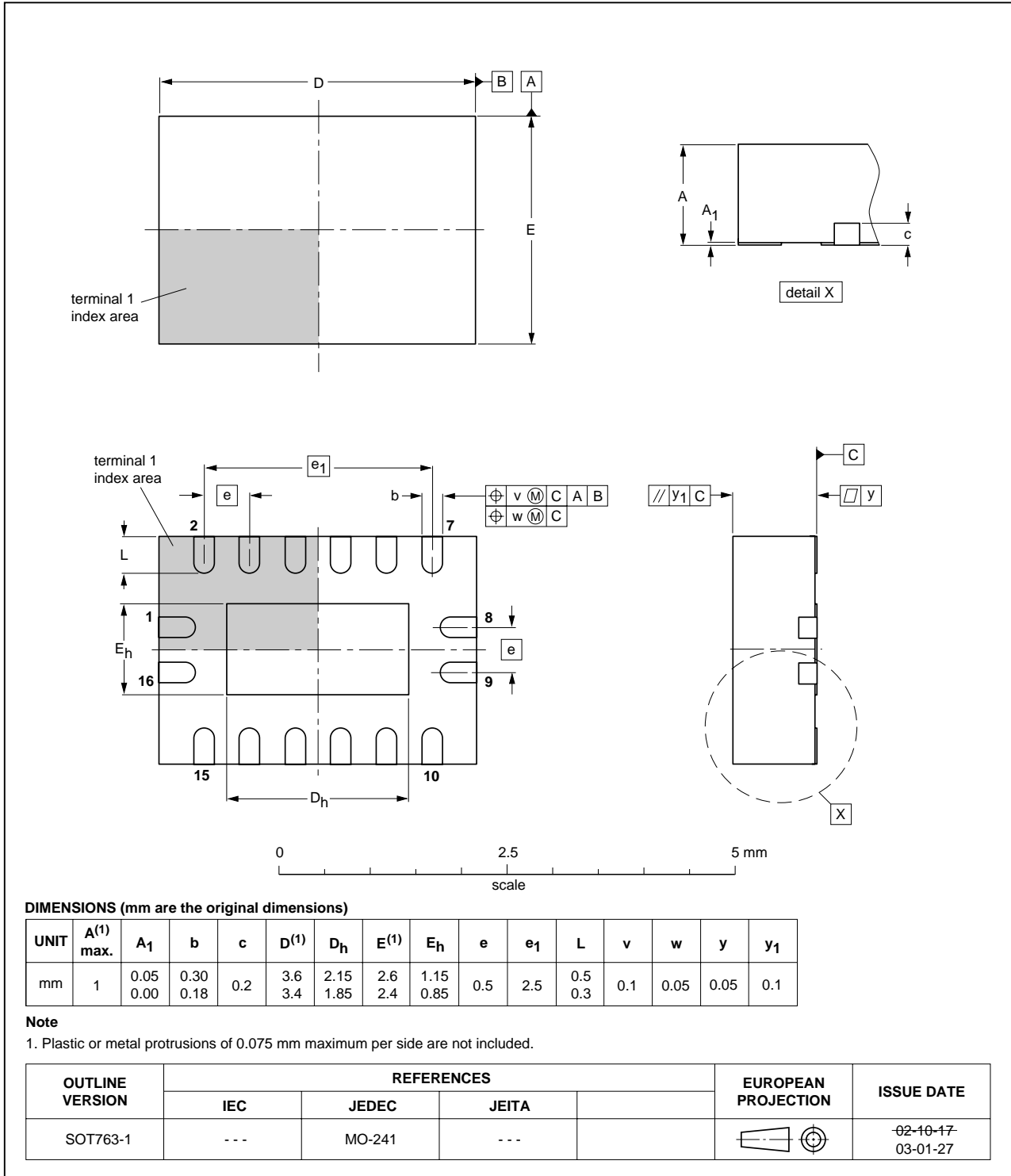

Fig 19. Package outline SOT763-1 (DHVQFN16)

13. Abbreviations

Table 10. Abbreviations

Acronym	Description
CDM	Charged Device Model
CMOS	Complementary Metal-Oxide Semiconductor
DUT	Device Under Test
ESD	ElectroStatic Discharge
HBM	Human Body Model
MM	Machine Model
TTL	Transistor-Transistor Logic

14. Revision history

Table 11. Revision history

Document ID	Release date	Data sheet status	Change notice	Supersedes
74HC590_2	20090428	Product data sheet	-	74HC590_1
Modifications:	<ul style="list-style-type: none"> • The format of this data sheet has been redesigned to comply with the new identity guidelines of NXP Semiconductors. • Legal texts have been adapted to the new company name where appropriate. • Quick reference data incorporated in to Section 9 and Section 10. • Added type number 74HC590N (DIP16 package) 			
74HC590_1	20050330	Product data sheet	-	-

15. Legal information

15.1 Data sheet status

Document status ^{[1][2]}	Product status ^[3]	Definition
Objective [short] data sheet	Development	This document contains data from the objective specification for product development.
Preliminary [short] data sheet	Qualification	This document contains data from the preliminary specification.
Product [short] data sheet	Production	This document contains the product specification.

[1] Please consult the most recently issued document before initiating or completing a design.

[2] The term 'short data sheet' is explained in section "Definitions".

[3] The product status of device(s) described in this document may have changed since this document was published and may differ in case of multiple devices. The latest product status information is available on the Internet at URL <http://www.nxp.com>.

15.2 Definitions

Draft — The document is a draft version only. The content is still under internal review and subject to formal approval, which may result in modifications or additions. NXP Semiconductors does not give any representations or warranties as to the accuracy or completeness of information included herein and shall have no liability for the consequences of use of such information.

Short data sheet — A short data sheet is an extract from a full data sheet with the same product type number(s) and title. A short data sheet is intended for quick reference only and should not be relied upon to contain detailed and full information. For detailed and full information see the relevant full data sheet, which is available on request via the local NXP Semiconductors sales office. In case of any inconsistency or conflict with the short data sheet, the full data sheet shall prevail.

15.3 Disclaimers

General — Information in this document is believed to be accurate and reliable. However, NXP Semiconductors does not give any representations or warranties, expressed or implied, as to the accuracy or completeness of such information and shall have no liability for the consequences of use of such information.

Right to make changes — NXP Semiconductors reserves the right to make changes to information published in this document, including without limitation specifications and product descriptions, at any time and without notice. This document supersedes and replaces all information supplied prior to the publication hereof.

Suitability for use — NXP Semiconductors products are not designed, authorized or warranted to be suitable for use in medical, military, aircraft, space or life support equipment, nor in applications where failure or malfunction of an NXP Semiconductors product can reasonably be expected to result in personal injury, death or severe property or environmental

damage. NXP Semiconductors accepts no liability for inclusion and/or use of NXP Semiconductors products in such equipment or applications and therefore such inclusion and/or use is at the customer's own risk.

Applications — Applications that are described herein for any of these products are for illustrative purposes only. NXP Semiconductors makes no representation or warranty that such applications will be suitable for the specified use without further testing or modification.

Limiting values — Stress above one or more limiting values (as defined in the Absolute Maximum Ratings System of IEC 60134) may cause permanent damage to the device. Limiting values are stress ratings only and operation of the device at these or any other conditions above those given in the Characteristics sections of this document is not implied. Exposure to limiting values for extended periods may affect device reliability.

Terms and conditions of sale — NXP Semiconductors products are sold subject to the general terms and conditions of commercial sale, as published at <http://www.nxp.com/profile/terms>, including those pertaining to warranty, intellectual property rights infringement and limitation of liability, unless explicitly otherwise agreed to in writing by NXP Semiconductors. In case of any inconsistency or conflict between information in this document and such terms and conditions, the latter will prevail.

No offer to sell or license — Nothing in this document may be interpreted or construed as an offer to sell products that is open for acceptance or the grant, conveyance or implication of any license under any copyrights, patents or other industrial or intellectual property rights.

Export control — This document as well as the item(s) described herein may be subject to export control regulations. Export might require a prior authorization from national authorities.

15.4 Trademarks

Notice: All referenced brands, product names, service names and trademarks are the property of their respective owners.

16. Contact information

For more information, please visit: <http://www.nxp.com>

For sales office addresses, please send an email to: salesaddresses@nxp.com

17. Contents

1 General description 1

2 Features 1

3 Ordering information 1

4 Functional diagram 2

5 Pinning information 4

5.1 Pinning 4

5.2 Pin description 4

6 Functional description 5

7 Limiting values 7

8 Recommended operating conditions 7

9 Static characteristics 8

10 Dynamic characteristics 9

11 Waveforms 11

12 Package outline 15

13 Abbreviations 19

14 Revision history 19

15 Legal information 20

15.1 Data sheet status 20

15.2 Definitions 20

15.3 Disclaimers 20

15.4 Trademarks 20

16 Contact information 20

17 Contents 21

Please be aware that important notices concerning this document and the product(s) described herein, have been included in section 'Legal information'.

