

1A Low Dropout Voltage Regulator, Adjustable Output, Fast Response

FEATURES

- Adjustable Output Down To 1.25V
- Low Quiescent Current
- Guaranteed 1.5A Peak Output Current
- Low Dropout Voltage of 280mV @ 1A
- Extremely Tight Load and Line Regulation
- Extremely Fast Transient Response
- Reverse-battery Protection
- Internal Thermal and Current Limit Protection
- Zero Current Shutdown
- Error Flag Output for Out of Regulation State
- Standard TO-220 and TO-263 packages
- Replacement for LM2941 and AS2941

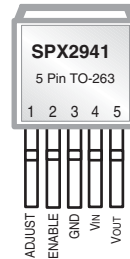

Now Available in Lead Free Packaging

APPLICATIONS

- Powering VGA & Sound Card
- LCD Monitors
- USB Power Supply
- Power PC Supplies
- SMPS Post-Regulator
- High Efficiency Linear Power Supplies
- Battery Charger
- Portable Instrumentation
- Constant Current Regulators
- Adjustable Power Supplies

DESCRIPTION

The SPX2941 is a 1A, accurate voltage regulator with a low drop out voltage of 280mV(typ.) at 1A. These regulators are specifically designed for low voltage applications that require a low dropout voltage and a fast transient response. They are fully fault protected against over-current, reverse battery, and positive and negative voltage transients. Other features include Enable, and Error Flag. The SPX2941 is offered in 5-pin TO-220 & TO-263 packages. For a 3A version, refer to the SPX29300 data sheet.

TYPICAL APPLICATIONS CIRCUIT

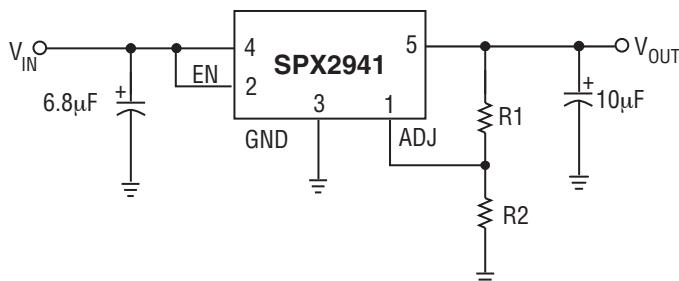

Figure 1. Adjustable Output Linear Regulator

ABSOLUTE MAXIMUM RATINGS

Lead Temperature (soldering, 5 seconds)260°C
Storage Temperature Range.....-65°C to +150°C

Operating Junction Temperature Range.....-40°C to +125°C
Input Supply Voltage (NOTE 7) 16V

ELECTRICAL CHARACTERISTICS

$V_{IN}=V_{OUT} + 1V$, $I_{OUT}=10mA$, $C_{IN}=6.8\mu F$, $C_{OUT}=10\mu F$, $T_A = 25^\circ C$, unless otherwise specified. The boldface applies over the junction temperature range. Adjustable versions are set at +5.0V.

PARAMETER	CONDITIONS	MIN.	TYP.	MAX	UNIT
Reference Voltage	Adjustable version only	1.228 1.215	1.240	1.252 1.265	V
Adjust Pin Bias Current			40	80 120	V
Reference Voltage Temperature Coefficient	(NOTE 4)		20		ppm/°C
Adjust Pin Bias Current Temperature Coefficient			0.1		nA/°C
Line Regulation	$I_{OUT}=10mA$, $(V_{OUT}+1V)\leq V_{IN}\leq 16V$		0.2	1.0	%
Load Regulation	$V_{IN}=V_{OUT}+1V$, $10mA\leq I_{OUT}\leq I_{FULL}$		0.3	1.5	%
Dropout Voltage (Note1) (except 1.8V version)	$I_{OUT}=100mA$ $I_{OUT}=1A$		70 280	200 550	mV
Ground Current (Note3)	$I_{OUT}=750mA$, $V_{IN}=V_{OUT}+1V$ $I_{OUT}=1A$		12 18	25	mA
Ground Pin Current at Dropout	$V_{IN}=0.1V$ less than specified V_{OUT} , $I_{OUT}=10mA$		1.2		mA
Current Limit	$V_{OUT}=0V$ (Note2)	1.5	2.2		A
Output Noise Voltage	10Hz to 100kHz, $I_{OUT}=100mA$, $C_L=10\mu F$ $C_L=33\mu F$		400 260		μV_{RMS}
ERROR COMPARATOR (FLAG OUTPUT)					
Output Leakage Current	$V_{OH}=16V$		0.1	1 2	A
Output Low Voltage	Device set for 5V, $V_{IN}=4.5$, $I_{OL}=250\mu A$		200	300 400	mV
Upper Threshold Voltage	Device set for 5V (Note 5)	40 25	60		mV
Lower Threshold Voltage	Device set for 5V (Note 5)		75	95 140	mV
Hysteresis	Device set for 5V (Note 5)		15		mV
Input Logic Voltage LOW (OFF) HIGH (ON)	$V_{IN}<10V$	2.4		0.8	V
ENABLE Input Pin Current	$V_{EN}=16V$		100	600 750	μA
	$V_{EN}=0.8V$			1 2	μA
Regulator Output Current in Shutdown	(NOTE 6)		10	500	μA
Thermal Resistance TO-220	Junction to Case, at Tab		3		°C/W
	Junction to Ambient		60		
TO-263	Junction to Case, at Tab		3		°C/W
	Junction to Ambient		60		

- NOTE 1: Dropout voltage is defined as the input to output differential at which the output voltage drops to 99% of its nominal value.
- NOTE 2: $V_{IN} = V_{OUT(NOMINAL)} + 1V$; for example, $V_{IN} = 4.3V$ for a 3.3V regulator. Employ pulse-testing procedures to minimize temperature rise.
- NOTE 3: Ground pin current is the regulator quiescent current. The total current drawn from the source is the sum of the load and ground currents.
- NOTE 4: Thermal regulation is defined as the change in the output voltage at a time T after a change in power dissipation is applied, excluding load or line regulation effects.
- NOTE 5: Comparator threshold is expressed in terms of a voltage differential at the Adjust terminal below the nominal reference voltage measured 6V input. To express these thresholds in terms of output voltage change, multiply the error amplifier gain $= V_{OUT}/V_{REF} = (R_1 + R_2)/R_2$. For example, at a programmable output voltage of 5V, the Error output is guaranteed to go low when the output drops by $95mV \times 5V / 1.240V = 38mV$. Threshold remain constant as a percent of V_{OUT} as V_{OUT} is varied, with the dropout warning occurring at typically 5% below nominal, 7.7% guaranteed.
- NOTE 6: $V_{EN} \leq 0.8V$ and $V_{IN} \leq 16V$, $V_{OUT} = 0$.
- NOTE 7: Maximum positive supply voltage of 20V must be of limited duration ($<100ms$) and duty cycle ($<1\%$). The maximum continuous supply voltage is 16V.
- NOTE 8: $V_{REF} \leq V_{OUT} \leq (V_{IN} - 1)$, $2.5V \leq V_{IN} \leq 16V$, $10\text{ mA} \leq I_C \leq I_{FL}$, $T_J < T_{JMAX}$.

BLOCK DIAGRAM

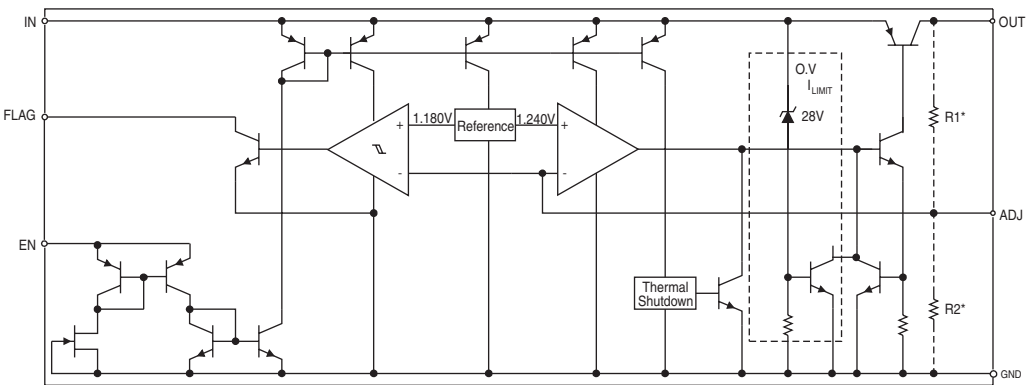

Figure 2. SP2941 Block Diagram

TYPICAL PERFORMANCE CHARACTERISTICS

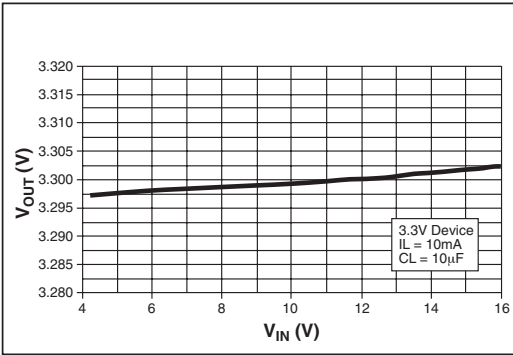

Figure 3. Line Regulation for 3.3V Device

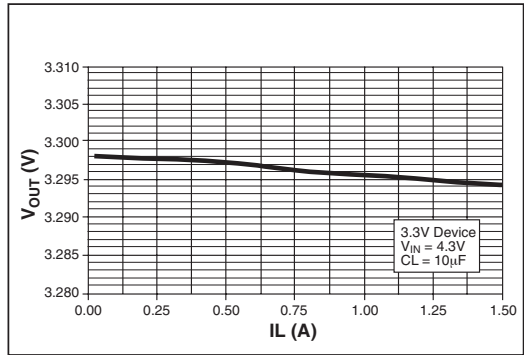

Figure 4. Load Regulation for 3.3V Device

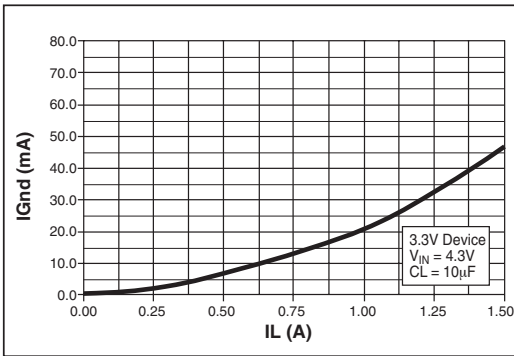

Figure 5. Ground Current vs Load Current for 3.3V Device

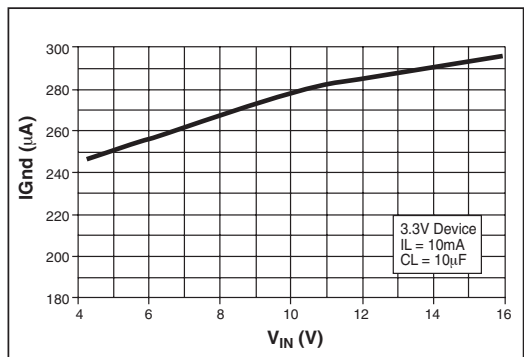

Figure 6. Ground Current vs Input Current

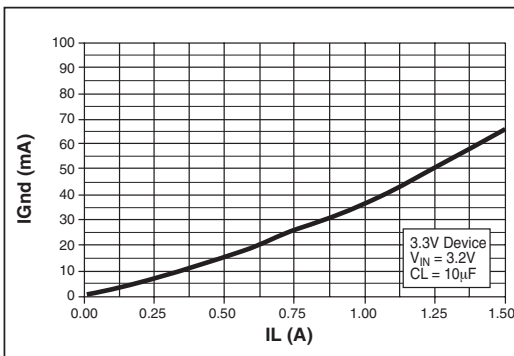

Figure 7. Ground Current vs Load Current in Dropout

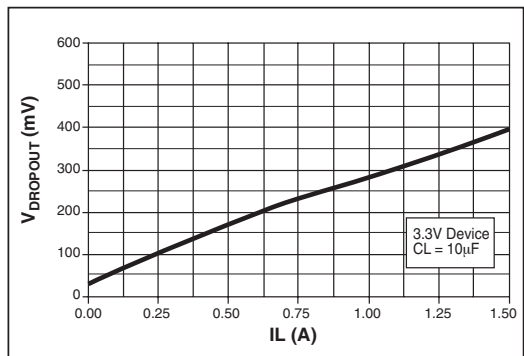

Figure 8. Dropout Voltage vs Load Current for 3.3V Device

TYPICAL PERFORMANCE CHARACTERISTICS

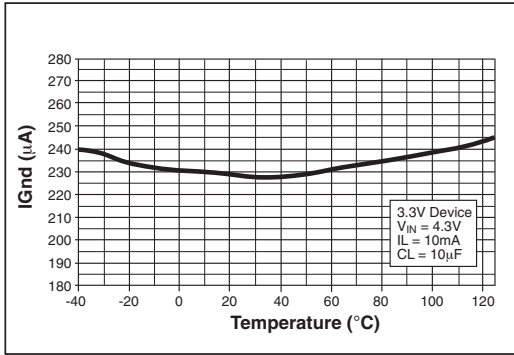

Figure 9. Ground Current vs Temperature at $I_{LOAD}=10mA$

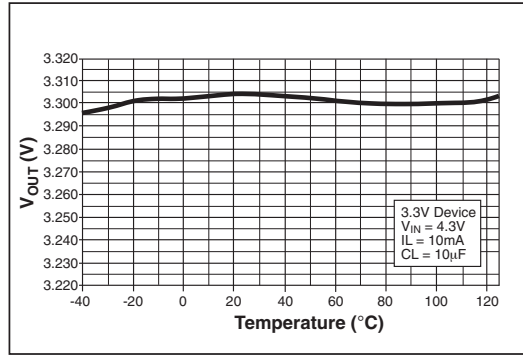

Figure 10. Output Voltage vs Temperature at $I_{LOAD}=10mA$

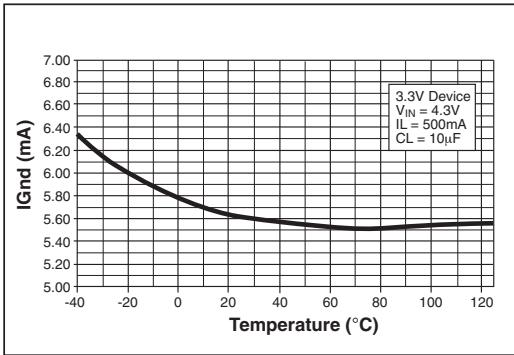

Figure 11. Ground Current vs Temperature at $I_{LOAD}=500mA$

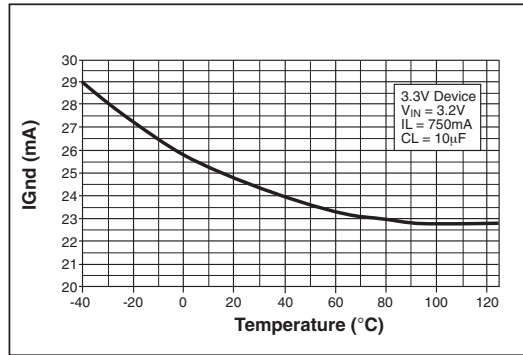

Figure 12. Ground Current vs Temperature in Dropout at $I_{LOAD}=750mA$

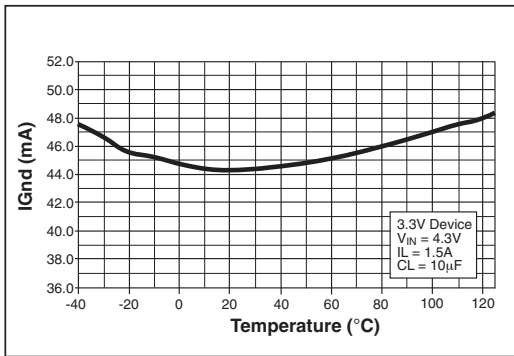

Figure 13. Ground Current vs Temperature at $I_{LOAD}=1.5A$

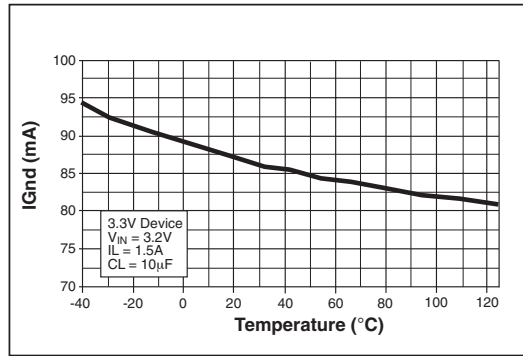

Figure 14. Ground Current vs Temperature in Dropout at $I_{LOAD}=1.5A$

TYPICAL PERFORMANCE CHARACTERISTICS

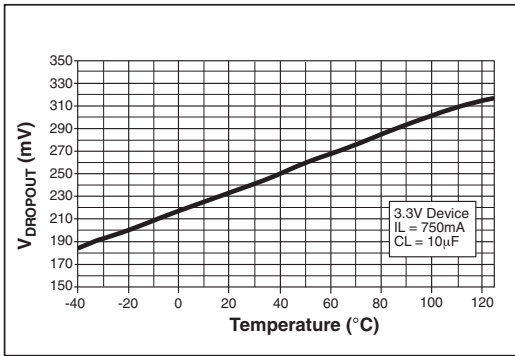

Figure 15. Dropout Voltage vs Temperature at $I_{LOAD}=750mA$

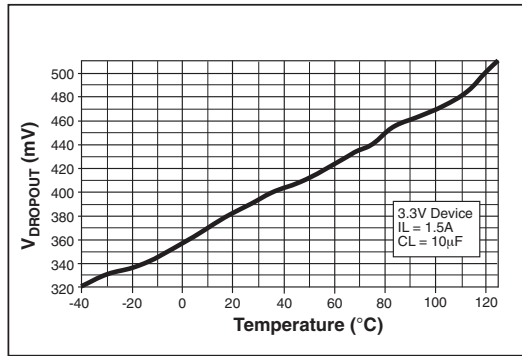

Figure 16. Dropout Voltage vs Temperature at $I_{LOAD}=1.5A$

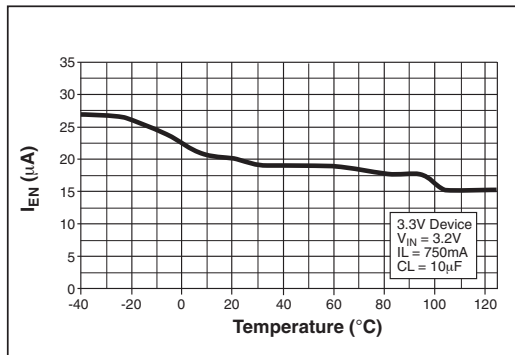

Figure 17. Enable Current vs Temperature for 3.3V Devices

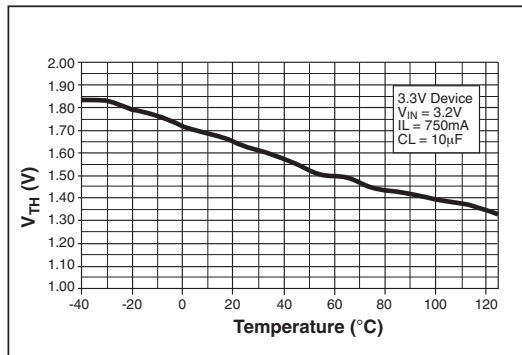

Figure 18. Enable Threshold vs Temperature for 3.3V Devices

APPLICATION INFORMATION

The SPX2941 incorporates protection against over-current faults, reversed load insertion, over temperature operation, and positive and negative transient voltage.

Thermal Considerations

Although the SPX2941 offers limiting circuitry for overload conditions, it is still necessary to insure that the maximum junction temperature is not exceeded in the application. Heat will flow through the lowest resistance path, the junction-to-case path. The tab of the device is electrically connected to GND. In order to insure the best thermal flow of the component, proper mounting is required. Consult heatsink manufacturer for thermal resistance and design of heatsink.

TO-220 Design Example:

Assume that $V_{IN} = 10V$, $V_{OUT} = 5V$, $I_{OUT} = 1A$, $T_A = 50^{\circ}C$, $\theta_{HA} = 1^{\circ}C/W$, $\theta_{CH} = 2^{\circ}C/W$, and $\theta_{JC} = 3^{\circ}C/W$, where

T_A = ambient temperature,

θ_{HA} = heatsink to ambient thermal resistance,

θ_{CH} = case to heatsink thermal resistance,

θ_{JC} = junction to case thermal resistance.

The power calculated under these conditions is:

$$P_D = (V_{IN} - V_{OUT}) * I_{OUT} = 5W,$$

and the junction temperature is calculated as $T_J = T_A + P_D * (\theta_{HA} + \theta_{CH} + \theta_{JC})$ or

$$T_J = 50 + 5.0 * (1 + 2 + 3) = 80^{\circ}C.$$

Reliable operation is insured.

Capacitor Requirements

The output capacitor is needed to insure stability and minimize the output noise. The value of the capacitor varies with the load. However, a minimum value of 10 μ F aluminum capacitor will guarantee stability over all load conditions. A tantalum capacitor is recommended if a faster load transient response is needed.

If the power source has a high AC impedance, a 0.1 μ F ceramic capacitor between input & ground is recommended.

Minimum Load Current

To ensure a proper behavior of the regulator under light load, a minimum load of 5mA for SPX2941 is required.

Typical Application Circuit

Figure 18 shows a typical applications circuit for an adjustable output regulator. The values of R_1 and R_2 set the output voltage value as follows: $V_{OUT} = V_{REF} * [1 + (R_1/R_2)]$. For best results, the total series resistance should be small enough to pass a minimum regulator load current of 5 mA.

A minimum value of 10k Ω is recommended for R_2 with a range between 10k Ω to 47k Ω .

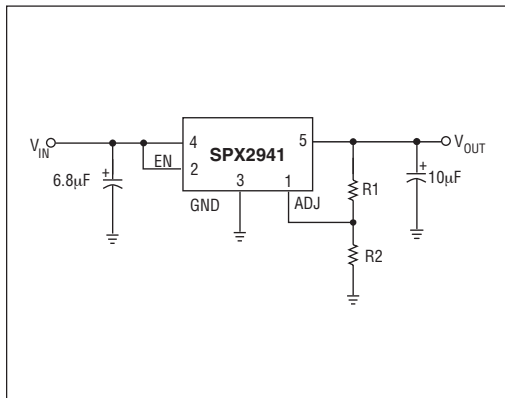
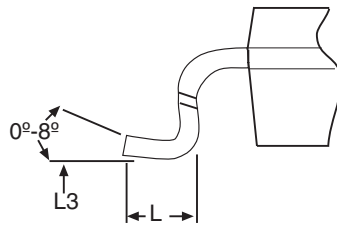
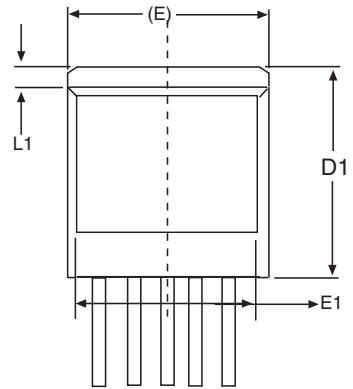
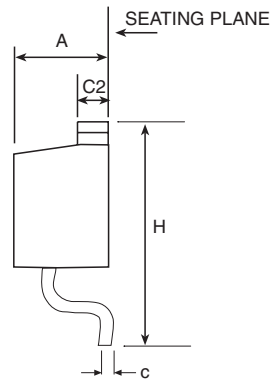
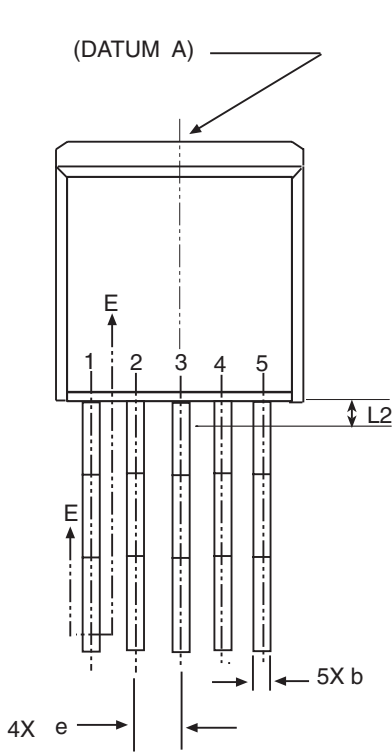
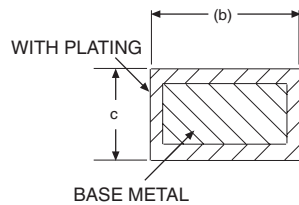

Figure 19. Adjustable Output Linear Regulator



5 PIN TO-263 JEDEC TO-263 (BB) Variation	Dimensions in (mm)		
	MIN	NOM	MAX
A	.160	-	.190
A1	0	-	.010
b	.020	-	.039
c	.015	-	.029
c2	.045	-	.023
D1	.270	-	-
E	.380	-	.420
E1	.245	-	-
e	.067 BSC		
H	.575	-	.625
L	.070	-	.110
L1	-	-	.066
L2	-	-	.070
L3	.010 BSC		



CONTACT AREA

5 PIN TO-263

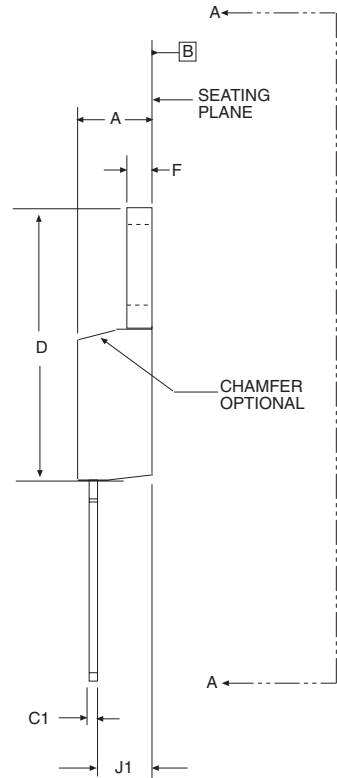
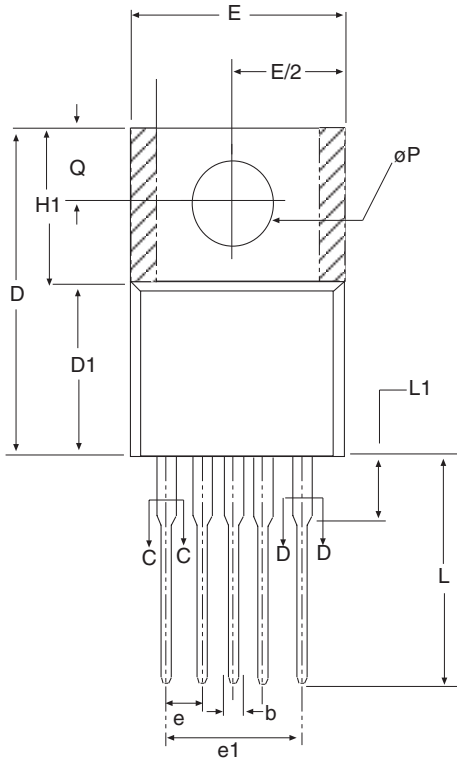

5 PIN TO-220	Dimensions in (inches)		
	MIN	NOM	MAX
A	.160	-	.190
b	.015	-	.040
C1	.014	-	.022
D	.560	-	.590
E	.385	-	.415
e	.385	-	.415
e1	.062	-	.072
F	.045	-	.055
H1	.234	-	.258
J1	.090	-	.115
L	.540	-	.560
L1		-	.250
ΔP	.146	-	.156
Q	.103	-	.113
U	-	.30	-
V	-	.24	-

5 PIN TO-220

PACKAGE PINOUTS

TO-263-5 Package (T5)

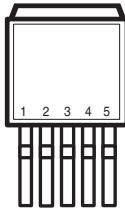

Top View

TO-220-5 Package (U5)

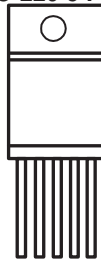

Top View

SPX2941

- 1) ADJUST
- 2) Enable
- 3) GND
- 4) V_{IN}
- 5) V_{OUT}

ORDERING INFORMATION

PART NUMBER	ACCURACY ...	OUTPUT VOLTAGE	PACKAGE
SPX2941T5	3%	Adj	5 lead TO-263
SPX2941T5/TR	3%	Adj	5 lead TO-263
SPX2941U5	3%	Adj	5 lead TO-220

Available in lead free packaging. To order add "-L" suffix to part number.

Example: SPX2941T5/TR = standard; SPX2941T5-L/TR = lead free

/TR = Tape and Reel

Pack quantity is 500 for TO-263.



ANALOG EXCELLENCE

Sipex Corporation

Headquarters and Sales Office

233 South Hillview Drive
 Milpitas, CA 95035
 TEL: (408) 934-7500
 FAX: (408) 935-7600

Sipex Corporation reserves the right to make changes to any products described herein. Sipex does not assume any liability arising out of the application or use of any product or circuit described herein; neither does it convey any license under its patent rights nor the rights of others.