



SPX2950/SPX2951

150mA Low Dropout Voltage Regulators

FEATURES

- 5.0V, 3.3V, and 3.0V Versions at 150mA Output
- Very Low Quiescent Current
- Low Dropout Voltage
- Extremely Tight Load and Line Regulation
- Very Low Temperature Coefficient
- Needs Only 1 μ F for Stability
- Current & Thermal Limiting
- Unregulated DC Input can Withstand -20V Reverse Battery and +60V Positive Transients
- Similar Replacement With Higher I_{OUT} for LP2950/LP2951 Sockets

APPLICATIONS

- Battery Powered Systems
- Cordless Telephones
- Radio Control Systems
- Portable/Palm Top/Notebook Computers
- Portable Consumer Equipment
- Portable Instrumentation
- Avionics
- Automotive Electronics
- SMPS Post-Regulator
- Voltage Reference

SPX2951 Versions Only

- Error Flag Warns of Output Dropout
- Logic-Controlled Electronic Shutdown
- Output Programmable From 1.24V to 29V

PRODUCT DESCRIPTION

The SPX2950 and SPX2951 are low power voltage regulators. These devices are an excellent choice for use in battery-powered applications such as cordless telephones, radio control systems, and portable computers. The SPX2950 and SPX2951 feature very low quiescent current and very low dropout voltage (Typ. 50mV at light load and 380mV at 100mA). This include a tight initial tolerance of 0.5% typ., extremely good load and line regulation of 0.05% typ. and very low output temperature coefficient, making the SPX2950/SPX2951 useful as a low-power voltage reference. Other key additional features of this device includes higher output current (150mA), positive transient protection up to 60V (Load dump), and the ability to survive an unregulated input voltage transient of -20V below ground (reverse battery).

The error flag output feature is used as power-on reset for warning of a low output voltage, due to falling voltage input of batteries. Another feature is the logic-compatible shutdown input which enables the regulator to be switched ON and OFF. The SPX2950 is offered in a 3-Pin TO-92 package compatible with other 5V regulators. The SPX2951 is also available in 8-Pin Plastic, SO-8 and TO-99 metal can packages.

The regulator output voltage may be pin-strapped for a 5V, 3.3V and 3.0V or programmed from 1.24V to 29V with an external pair of resistors. Look for SPX2954 for 250mA and SPX2955 for 350mA.

PIN CONNECTIONS

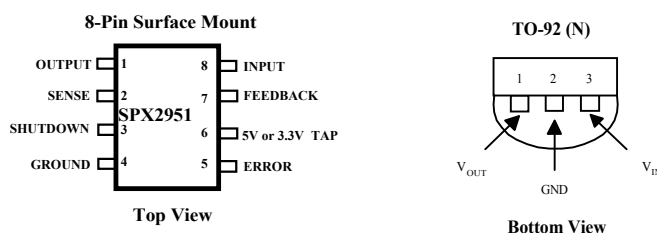

SPX2950/SPX2951

ABSOLUTE MAXIMUM RATINGS

Power Dissipation.....	Internally Limited
Lead Temp. (Soldering, 5 Seconds)	260°C
Storage Temperature Range	-65°C to +150°C
Operating Junction Temperature Range	
SPX2951	-55°C to +150°C
SPX2950AC/SPX2950C	
SPX2951AC/SPX2951C	-40°C to +125°C

Input Supply Voltage (Survival)	-20 to +60V
Feedback Input Voltage	-1.5 to +30V
Shutdown Input Voltage.....	-0.3 to +30V
Error Comparator Output.....	-0.3 to +30V
ESD Rating	2KV Min

ELECTRICAL CHARACTERISTICS at $V_S=15V$, $T_A=25^\circ C$, unless otherwise specified.

PARAMETER	CONDITIONS	SPX2951			SPX2950C/SPX2951C			SPX2950C/SPX2951C			UNITS
		Min	Typ	Max	Min	Typ	Max	Min	Typ	Max	
3.0V Version											
Output Voltage	$T_J = 25^\circ C$ $-25^\circ C \leq T_J \leq 85^\circ C$ Full Operating Temperature	2.985	3.0	3.015	2.985	3.0	3.015	2.970	3.0	3.030	V
		2.964		3.036	2.964	3.0	3.036	2.940	3.0	3.060	
Output Voltage	$100mA \leq I_L \leq 150mA$ $T_J \leq T_{JMAX}$	2.955	3.0	3.045	2.958	3.0	3.042	2.928	3.0	3.072	V
3.3V Version											
Output Voltage	$T_J = 25^\circ C$ $-25^\circ C \leq T_J \leq 85^\circ C$ Full Operating Temperature	3.284	3.3	3.317	3.284	3.3	3.317	3.267	3.3	3.333	V
		3.260		3.340	3.260	3.3	3.340	3.234	3.3	3.366	
Output Voltage	$100mA \leq I_L \leq 150mA$ $T_J \leq T_{JMAX}$	3.251	3.3	3.350	3.254	3.3	3.346	3.221	3.3	3.379	V
5.0V Version											
Output Voltage	$T_J = 25^\circ C$ $-25^\circ C \leq T_J \leq 85^\circ C$ Full Operating Temperature	4.975	5.0	5.025	4.975	5.0	5.025	4.95	5.0	5.05	V
		4.94		5.06	4.94	5.0	5.06	4.90	5.0	5.10	
Output Voltage	$100\mu A \leq I_L \leq 150mA$ $T_J \leq T_{JMAX}$	4.925	5.0	5.075	4.93	5.0	5.07	4.88	5.0	5.12	V
All Voltage Options											
Output Voltage Temperature Coefficient	(Note 1)		20	120		20			50		ppm/ $^\circ C$
Line Regulation (Note 3)	$6V \leq V_{IN} \leq 30V$ (Note 4)		0.03	0.1		0.03	0.1		0.04	0.2	%
Load Regulation (Note 3)	$100mA \leq I_L \leq 150mA$		0.04	0.1		0.04	0.1		0.1	0.2	%
Dropout Voltage (Note 5)	$I_L = 100\mu A$ $I_L = 100mA$ $I_L = 150mA$		50 380 450	80 450 500		50 380 450	80 450 500		50 380 450	80 450 500	mV
Ground Current	$I_L = 100\mu A$ $I_L = 100mA$ $I_L = 150mA$		150 3 5	170 6 8		150 3 5	170 6 8		150 3 5	170 6 8	μA mA mA
Current Limit	$V_{OUT} = 0$		130	200		130	200		130	200	mA
Thermal Regulation			0.05	0.2		0.05	0.2		0.05	0.2	%/W
Output Noise, 10Hz to 100KHz	$C_L = 1\mu F$ $C_L = 200\mu F$ $C_L = 13.3\mu F$ (bypass = 0.01 μF pins 6 to 1 (SPX2951))		430 160 100			430 160 100			430 160 100		μV_{rms} μV_{rms} μV_{rms}
8-Pin Version Only		SPX2951			SPX2951AC			SPX2951C			
Reference Voltage		1.22	1.235	1.25	1.22	1.235	1.25	1.21	1.23	1.26	V
Reference Voltage	Over Temperature (Note 6)	1.19		1.27	1.19		1.27	1.18		1.28	V

SPX2950/SPX2951

PARAMETER	CONDITIONS (Note 2)	SPX2951			SPX2950AC SPX2951AC		SPX2950C SPX2951C		UNITS		
		Min	Typ	Max	Min Max	Typ	Min Max	Typ			
8-Pin Version only (Continued)											
Feedback Pin Bias Current			40	60		40	60		40	60	nA
Reference Voltage Temperature Coefficient	(Note 7)		20			20			50		ppm/°C
Feedback Pin Bias Current Temperature Coefficient			0.1			0.1			0.1		nA/°C
Error Comparator											
Output Leakage Current	$V_{OH} = 30V$		0.01	1		0.01	1		0.01	1	μA
Output Low Voltage	$V_{IN} = 4.5V$ $I_{OL} = 400\mu A$		150	250		150	250		150	250	mV
Upper Threshold Voltage	(Note 8)	40	60		40	60		40	60		mV
Lower Threshold Voltage	(Note 8)		75	95		75	95		75	95	mV
Hysteresis	(Note 8)		15			15			15		mV
Shutdown Input											
Input logic Voltage	Low (Regulator ON) High (Regulator OFF)	2	1.3	0.6	2	1.3	0.7	2	1.3	0.7	V V
Shut down Pin Input Current	$V_S = 2.4V$ $V_S = 30V$		30 675	50 800		30 675	50 800		30 675	50 800	μA μA
Regulator Output Current in Shutdown	(Note 9)		3	10		3	10		3	10	μA

Note 1: Output or reference voltage temperature coefficients defined as the worst case voltage change divided by the total temperature range.

Note 2: Unless otherwise specified all limits guaranteed for $T_J = 25^\circ C$, $V_{IN} = 6V$, $I_L = 100 \mu A$ and $C_L = 1 \mu F$. Additional conditions for the 8-pin versions are feedback tied to 5V Tap and output tied to output sense ($V_{OUT} = 5V$) and $V_{SHUTDOWN} \leq 0.8V$.

Note 3: Regulation is measured at constant junction temperature, using pulse testing with a low duty cycle. Changes in output voltage due to heating effects are covered under the specification for thermal regulation.

Note 4: Line regulation for the SPX2951 is tested at $150^\circ C$ for $I_L = 1 \text{ mA}$. For $I_L = 100 \mu A$ and $T_J = 125^\circ C$, line regulation is guaranteed by design to 0.2%. See typical performance characteristics for line regulation versus temperature and load current.

Note 5: Dropout voltage is defined as the input to output differential at which the output voltage drops 100 mV below its nominal value measured at 1V differential at very low values of programmed output voltage, the minimum input supply voltage of 2V (2.3V over temperature) must be taken into account.

Note 6: $V_{REF} \leq V_{OUT} \leq (V_{IN} - 1V)$, $2.3 \leq V_{IN} \leq 30V$, $100\mu A \leq I_L \leq 150 \text{ mA}$, $T_J \leq T_{JMAX}$.

Note 7: Output or reference voltage temperature coefficient is defined as the worst case voltage change divided by the total temperature range.

Note 8: Comparator thresholds are expressed in terms of a voltage differential at the feedback terminal below the nominal reference voltage measured at 6V input. To express these thresholds in terms of output voltage change, multiply by the error amplifier gain = $V_{OUT}/V_{REF} = (R_1 + R_2)/R_2$. For example, at a programmed output voltage of 5V, the Error output is guaranteed to go low when the output drops by $95 \text{ mV} \times 5V/1.235 = 384 \text{ mV}$. Thresholds remain constant as a percent of V_{OUT} as V_{OUT} is varied, with the dropout warning occurring at typically 5% below nominal, 7.5% guaranteed.

Note 9: $V_{SHUTDOWN} \geq 2V$, $V_{IN} \leq 30V$, $V_{OUT} = 0$, Feedback pin tied to 5V Tap.

Note 10: All typical values are not guaranteed. The value could vary from lot to lot.

BLOCK DIAGRAM

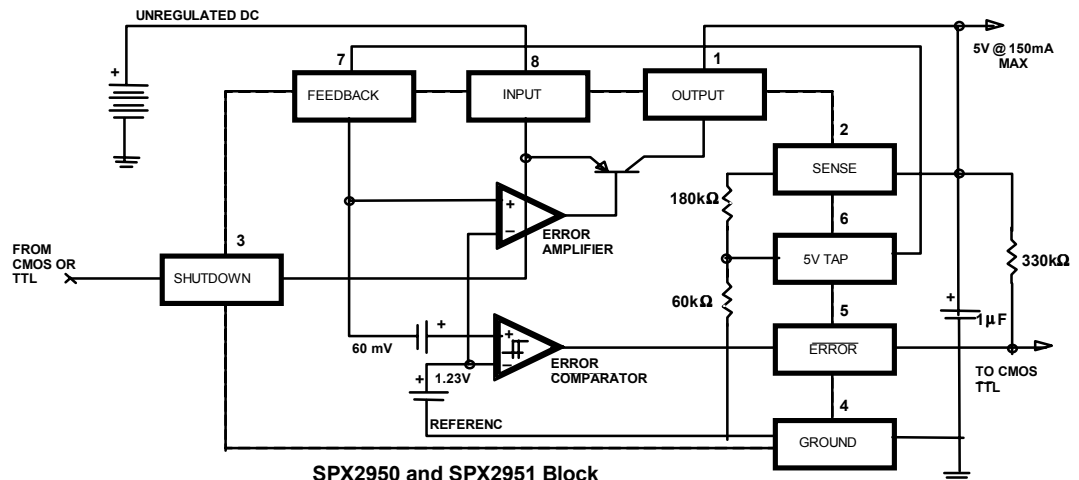

APPLICATION HINTS

EXTERNAL CAPACITORS

The stability of the SPX2950/SPX2951 requires a 1.0 μ F or greater capacitor between output and ground. Oscillation could occur without this capacitor. Most types of tantalum or aluminum electrolytic works fine here. For operations below -25°C solid tantalum is recommended since many aluminum types have electrolytes that freeze at about -30°C. The ESR of about 5 Ω or less and resonant frequency above 500kHz are the most important parameters in the value of the capacitor. The capacitor value can be increased without limit.

At lower values of output current, less output capacitance is required for stability. For the currents below 10mA the value of the capacitor can be reduced to 0.5 μ F and 0.15 μ F for 1mA. More output capacitance is needed for the 8-pin version at voltages below 5V since it runs the error amplifier at lower gain. At worst case 5 μ F or greater must be used for the condition of 150mA load at 1.23V output.

The SPX2950, unlike other low dropout regulators will remain stable in regulation with no load in addition to the internal voltage divider. This feature is especially important in applications like CMOS RAM keep-alive. When setting the output voltage of the SPX2951 version with external resistors, a minimum load of 1 μ A is recommended.

If there is more than 10 inches of wire between the input and the AC filter capacitor or if a battery is used as the input then a 1 μ A tantalum or aluminum electrolytic capacitor should be placed from the input to the ground.

Instability can occur if there is stray capacitance to the SPX2951 feedback terminal (pin 7). This could cause more problems when using a higher value of external resistors to set the output voltage. This problem can be fixed by adding a 100pF capacitor between output and feedback and increasing the output capacitor to at least 3.3 μ F.

ERROR DETECTION COMPARATOR OUTPUT

The Comparator produces a logic low output whenever the SPX2951 output falls out of regulation by more than around 5%. This is around 60mV offset divided by the 1.235 reference voltage. This trip level remains 5% below normal regardless of the programmed output voltage of the regulator. Figure 1 shows the timing diagram depicting the ERROR signal and the regulator output voltage as the SPX2951 input is ramped up and down. The ERROR signal becomes low at around 1.3V input, and goes high around 5V input (input voltage at which $V_{OUT} = 4.75$). Since the SPX2951's dropout voltage is load dependent, the input voltage trip point (around 5V) will vary with the load current. The output voltage trip point (approx. 4.75V) does not vary with load.

The error comparator has an open-collector output which requires an external pull-up resistor. Depending on the system requirements the resistor may be returned to 5V output or other supply voltage in determining the value of this resistor, note that the output is rated to sink 400 μ A, this value adds to battery drain in a low battery condition. Suggested values range from 100K to 1M Ω . If the output is unused this resistor is not required.

PROGRAMMING THE OUTPUT VOLTAGE OF SPX2951

The SPX2951 may be pin-strapped for 5V using its internal voltage divider by tying Pin 1 (output) to Pin 2 (sense) and Pin 7 (feedback) to Pin 6 (5V Tap). Also it may be programmed for any output voltage between its 1.235V reference and its 30V maximum rating. As seen in Figure 2, an external pair of resistors is required.

Refer to the below equation for the programming of the output voltage.

$$V_{OUT} = V_{REF} \times (1 + R_1/R_2) + I_{FB}R_1$$

The V_{REF} is 1.235 and I_{FB} is the feedback bias current, nominally -20 nA. The minimum recommended load current of 1 μ A forces an upper limit of 1.2 M Ω on value of R_2 . If no load presented the I_{FB} produces an error of typically 2% in V_{OUT} which may be eliminated at room temperature by trimming R_1 . To improve the accuracy choose the value of $R_2 = 100k$ this reduces the error by 0.17% and increases the resistor program current by 12 μ A. Since the SPX2951 typically draws 60 μ A at no load with Pin 2 open-circuited this is a small price to pay.

REDUCING OUTPUT NOISE

It may be an advantage to reduce the AC noise present at the output. One way is to reduce the regulator bandwidth by increasing the size of the output capacitor. This is the only way that noise can be reduced on the SPX2950 but is relatively inefficient, as increasing the capacitor from 1 μ F to 220 μ F only decreases the noise from 430 μ V to 160 μ V_{RMS}. for a 100kHz bandwidth at 5V output.

Noise could also be reduced fourfold by a bypass capacitor across R_1 , since it reduces the high frequency gain from 4 to unity. Pick

$$C_{BYPASS} \cong 1 / 2\pi R_1 \times 200 \text{ Hz}$$

or choose 0.01 μ F. When doing this, the output capacitor must be increased to 3.3 μ F to maintain stability. These changes reduce the output noise from 430 μ V to 100 μ V_{RMS}. for a 100kHz bandwidth at 5V output. With the bypass capacitor added, noise no longer scales with output voltage so that improvements are more dramatic at higher output voltages.

TYPICAL PERFORMANCE CHARACTERISTICS

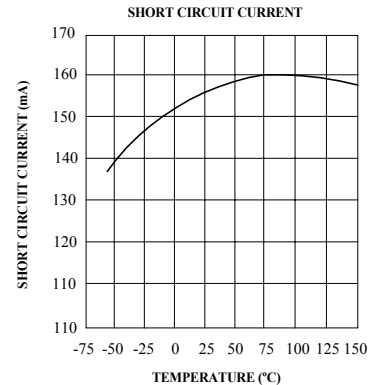
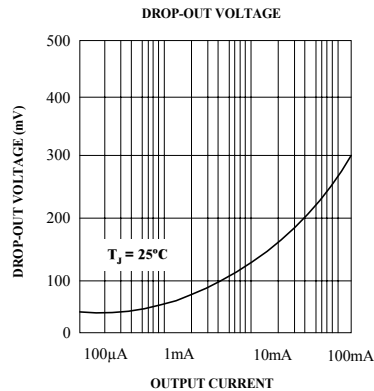
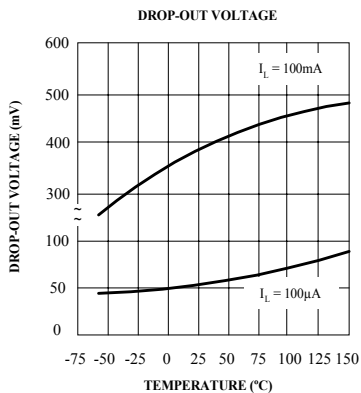
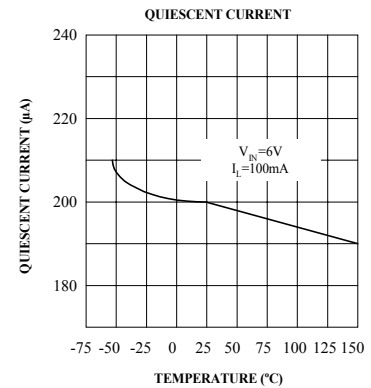
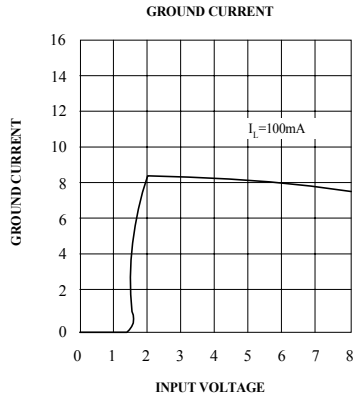
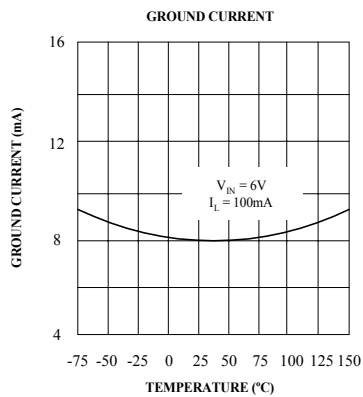
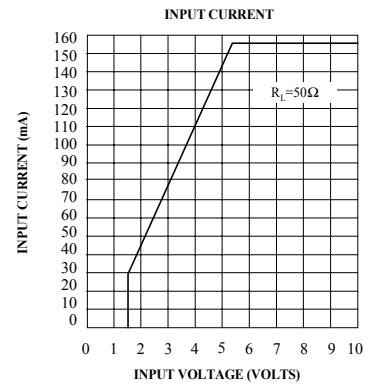
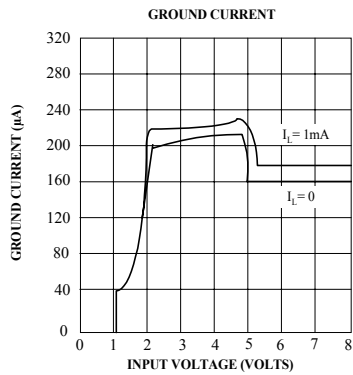
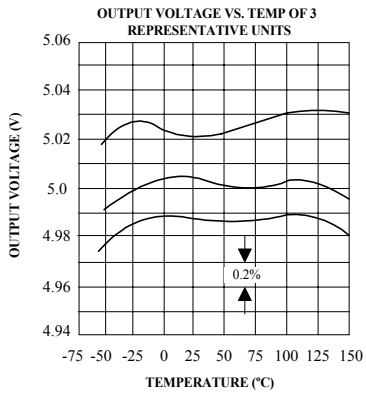
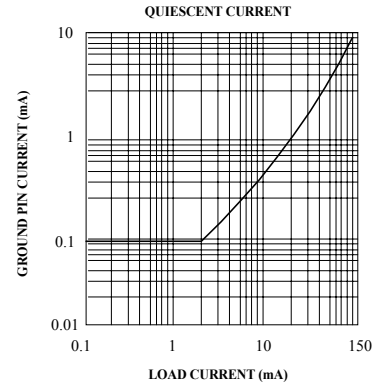
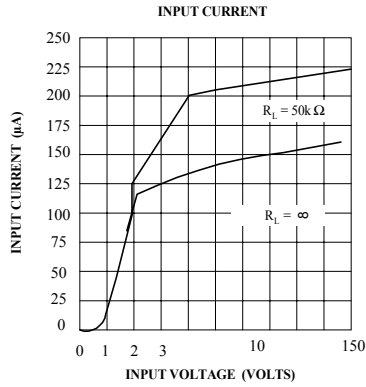
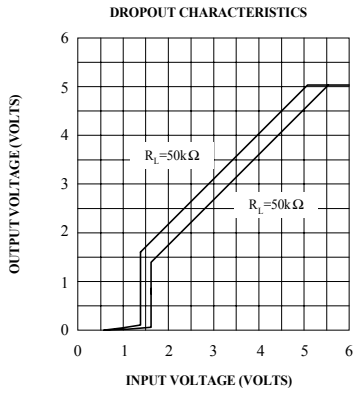

TYPICAL PERFORMANCE CHARACTERISTICS (continued)

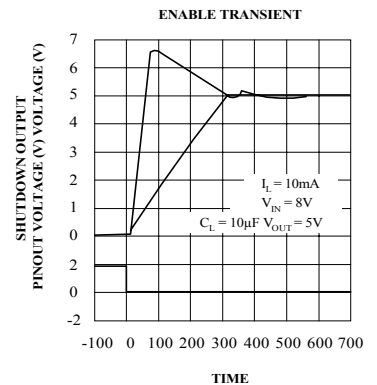
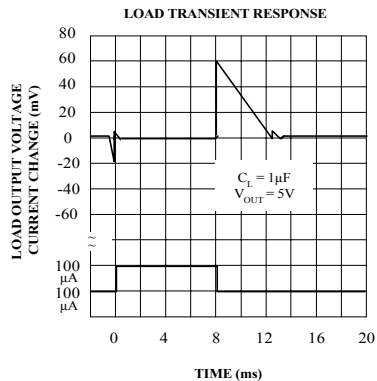
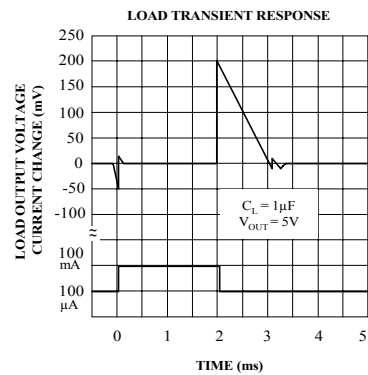
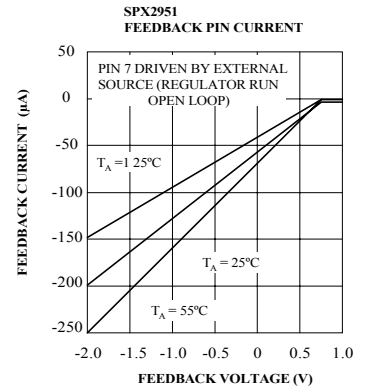
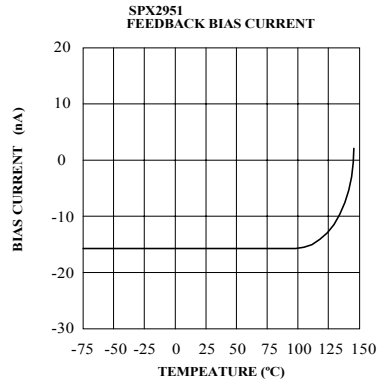
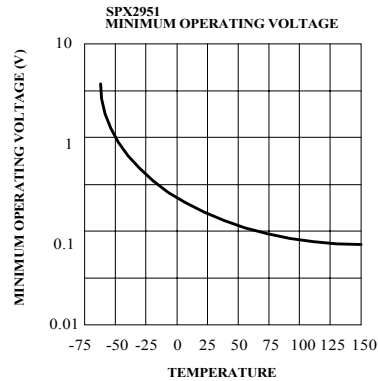
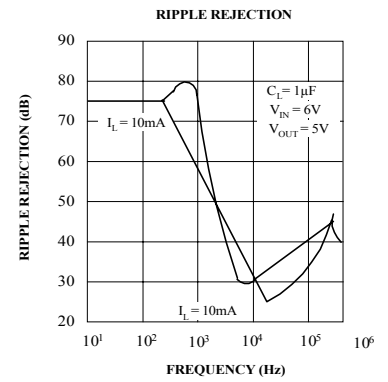
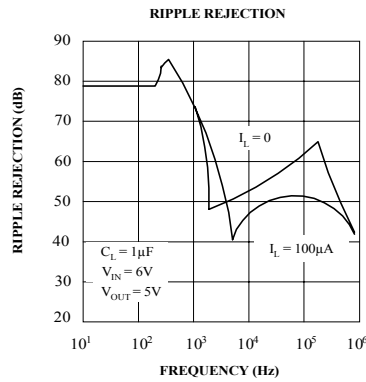
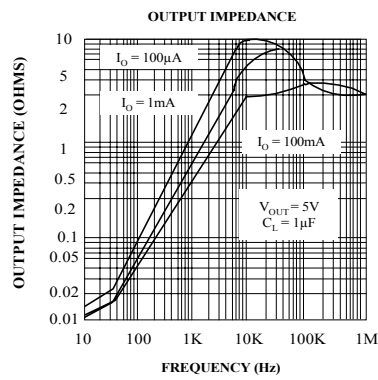
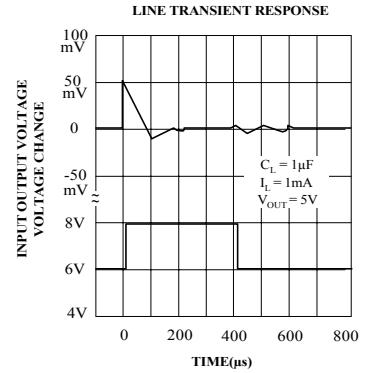
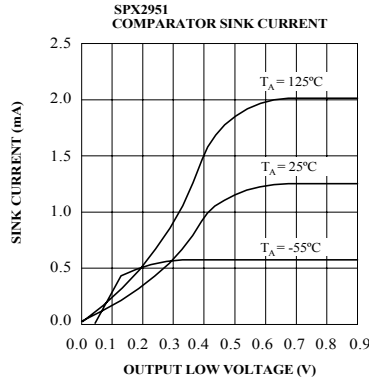
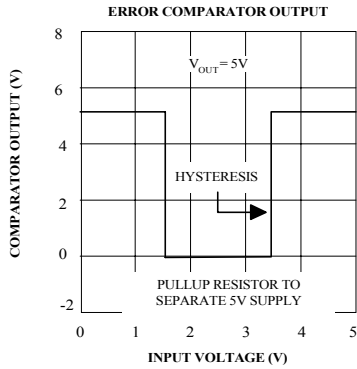

TYPICAL PERFORMANCE CHARACTERISTICS (continued)

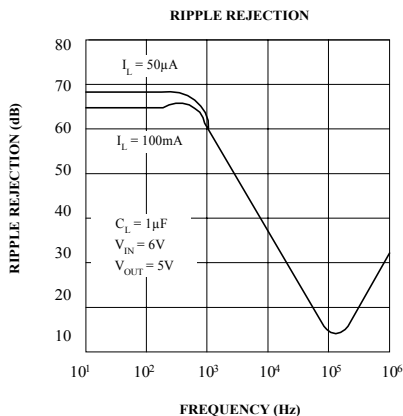
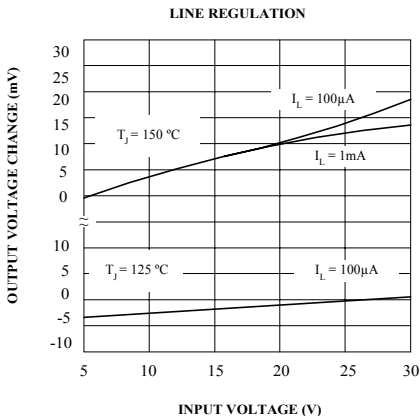
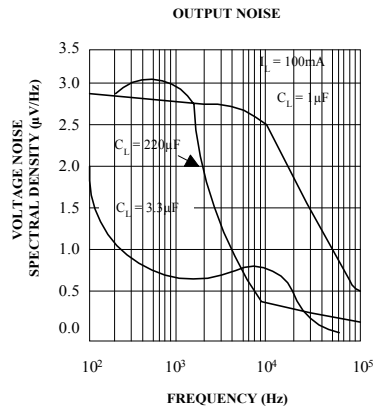
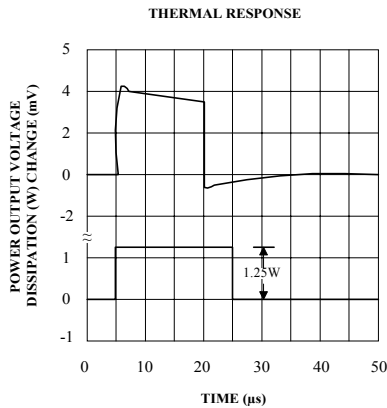
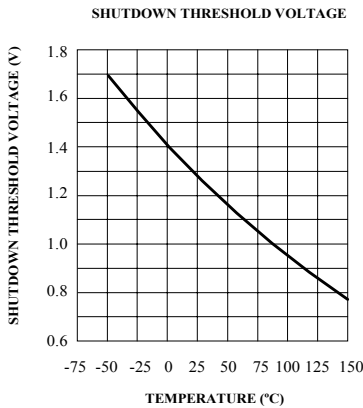
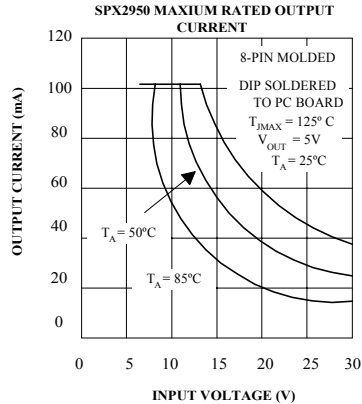
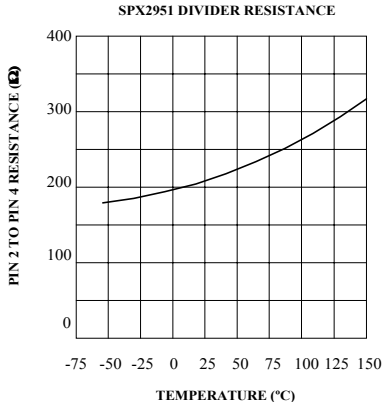
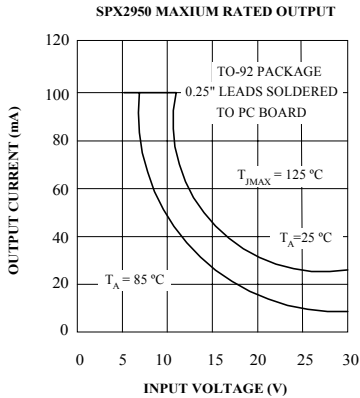

TYPICAL APPLICATIONS

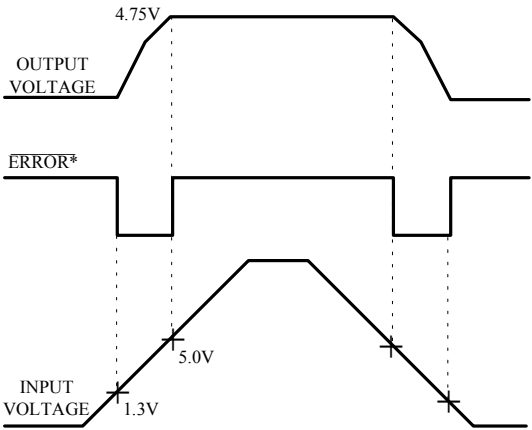

* See Application Info.

Figure 1. ERROR Output Timing

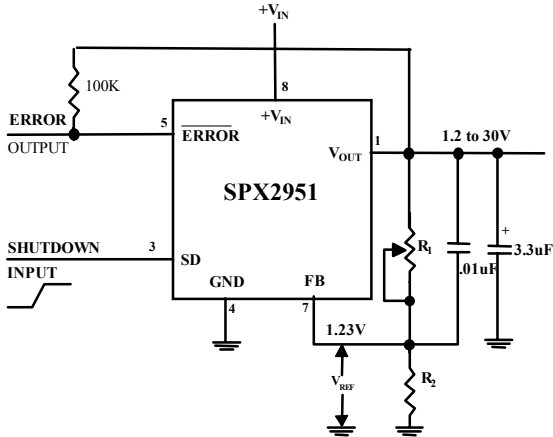
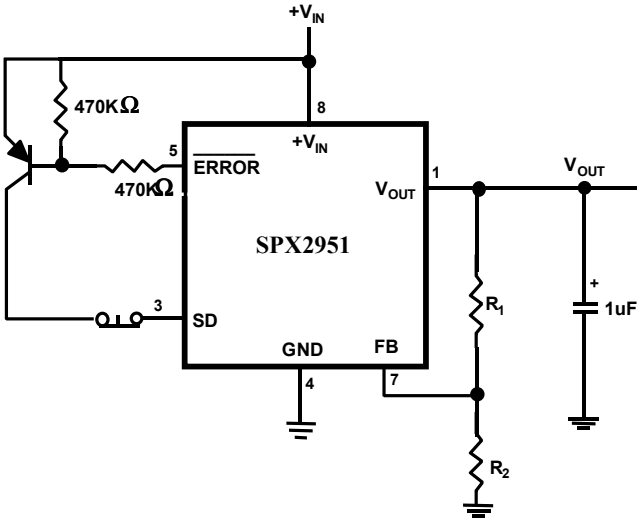
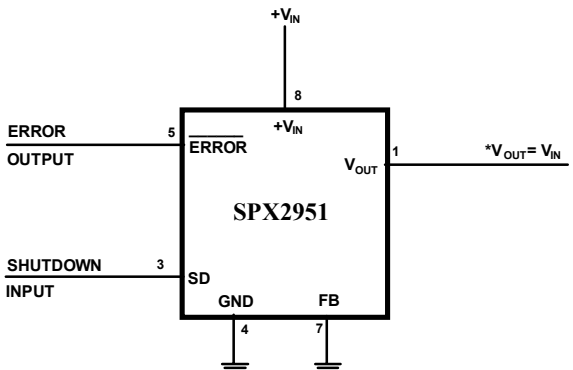

Figure 2. Adjustable Regulator



Latch Off When Error Flag Occurs



*MINIMUM INPUT-OUTPUT VOLTAGE RANGES FROM 4mV to 400mV. DEPENDING ON LOAD CURRENT. CURRENT LIMIT IS TYPICALLY 160mA

Wide Input Voltage Range Current Limiter

TYPICAL APPLICATIONS (Continued)

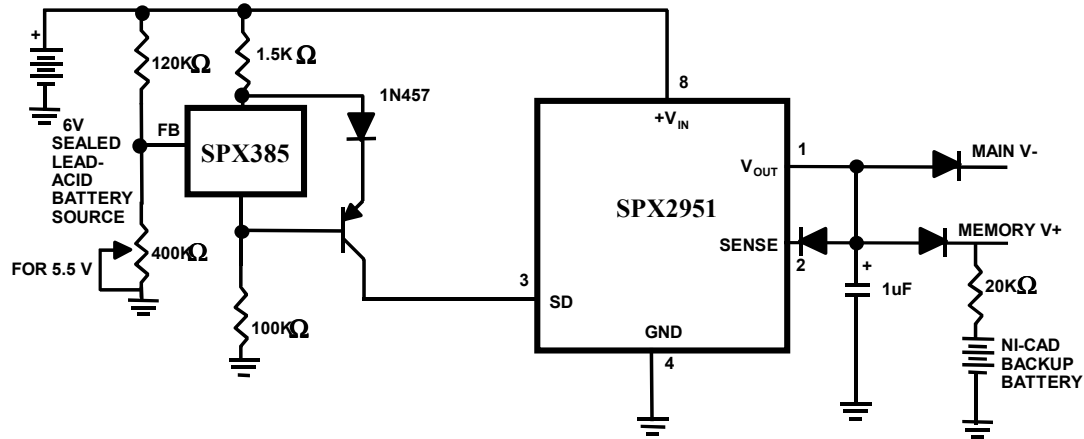

Low Battery Disconnect

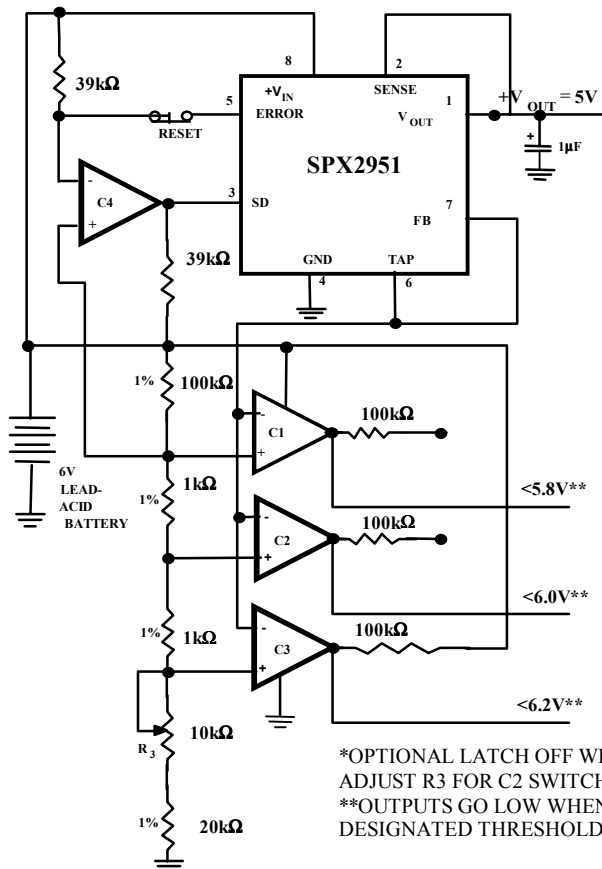

*OPTIONAL LATCH OFF WHEN DROPOUT OCCURS.
 ADJUST R3 FOR C2 SWITCHING V_{IN} IS 6.0V.
 **OUTPUTS GO LOW WHEN V_{IN} DROPS BELOW
 DESIGNATED THRESHOLDS.

Regulator with State-of-Charge Indicator

TYPICAL APPLICATIONS (continued)

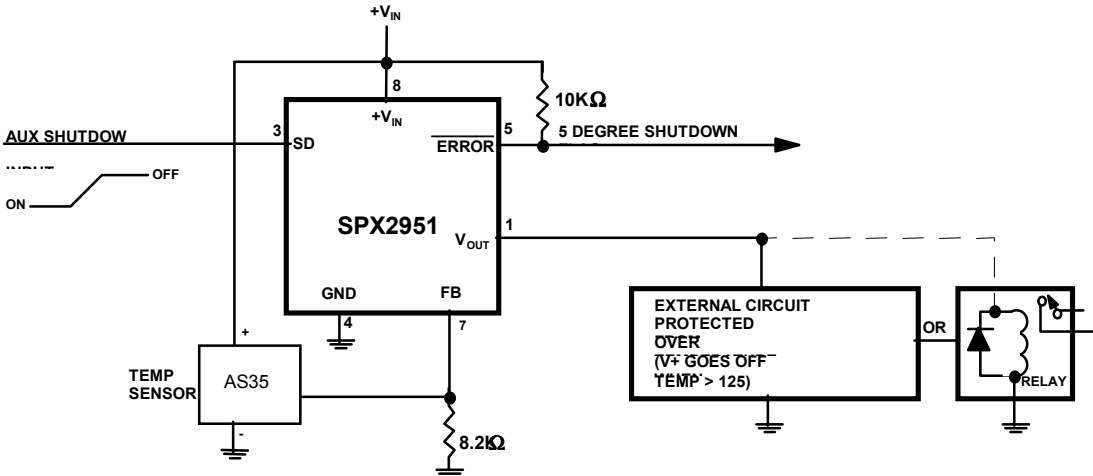

System Over Temperature Protection Circuit

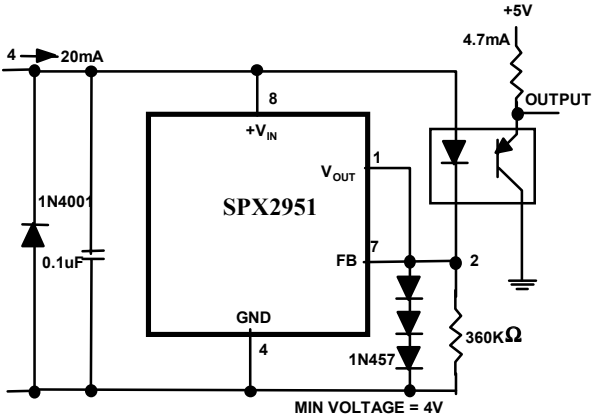

Open Circuit Detector for 4mA to 20mA Current Loop

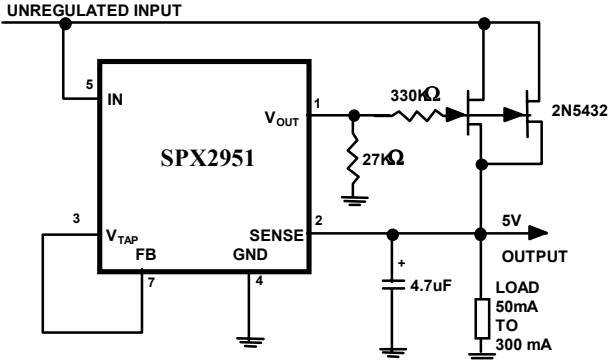

300 mA Regulator with 0.75 Dropout

SCHEMATIC DIAGRAM

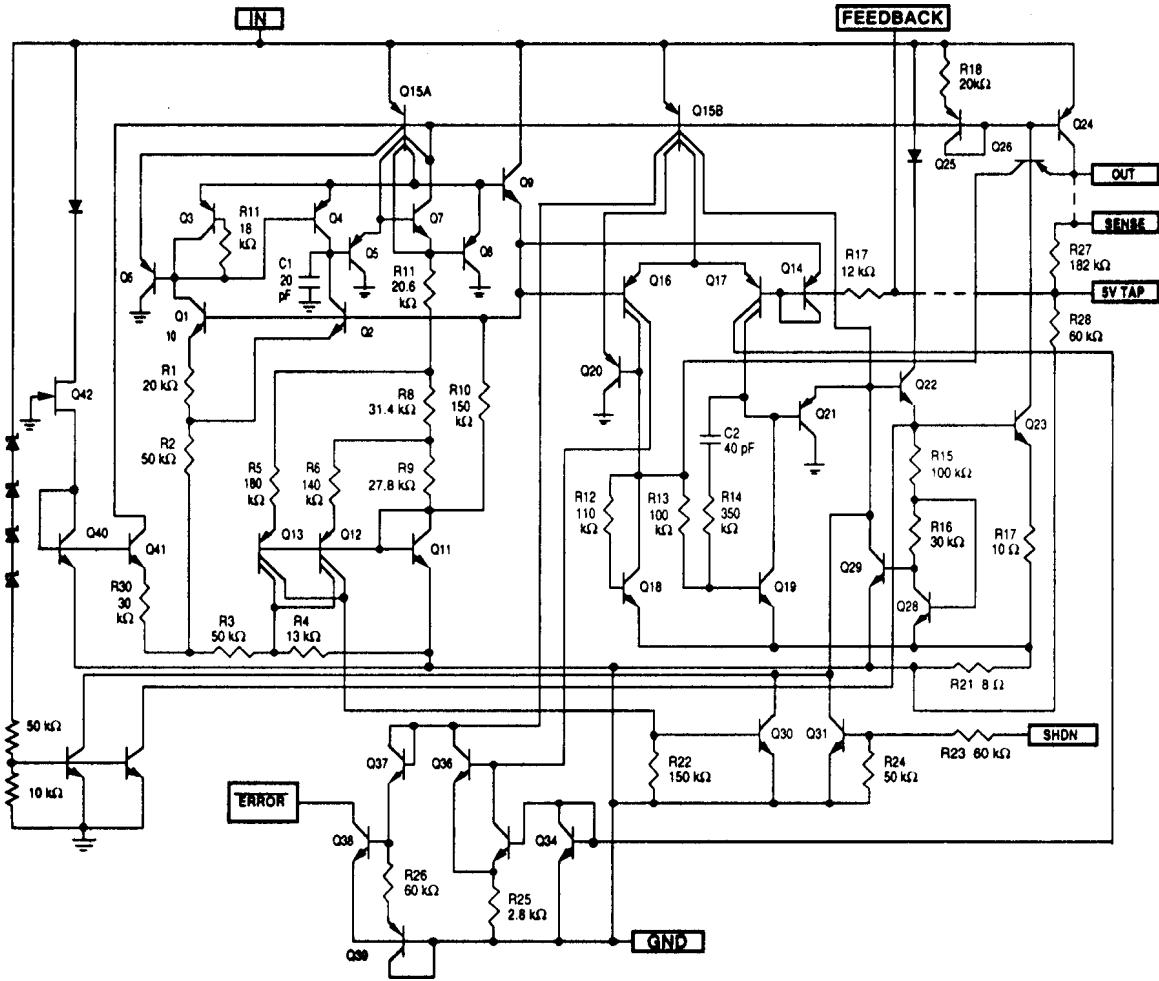

ORDERING INFORMATION

Ordering No.	Precision	Output Voltage	Packages
SPX2950CN-3.0	1%	3.0V	3 Lead TO-92
SPX2950CN-3.3	1%	3.3V	3 Lead TO-92
SPX2950CN-5.0	1%	5.0V	3 Lead TO-92
SPX2950ACN-3.0	0.5%	3.0V	3 Lead TO-92
SPX2950ACN-3.3	0.5%	3.3V	3 Lead TO-92
SPX2950ACN-5.0	0.5%	5.0V	3 Lead TO-92
SPX2951CS-3.0	1%	3.0V	8 Lead SOIC
SPX2951CS-3.3	1%	3.3V	8 Lead SOIC
SPX2951CS-5.0	1%	5.0V	8 Lead SOIC
SPX2951ACS-3.0	0.5%	3.0V	8 Lead SOIC
SPX2951ACS-3.3	0.5%	3.3V	8 Lead SOIC
SPX2951ACS-5.0	0.5%	5.0V	8 Lead SOIC



SIGNAL PROCESSING EXCELLENCE

Sipex Corporation

Headquarters and Main Offices:

22 Linnell Circle
Billerica, MA 01821
TEL: (978) 667-8700
FAX: (978) 670-9001
e-mail: sales@sipex.com

233 South Hillview Drive
Milpitas, CA 95035
TEL: (408) 935-7600
FAX: (408) 934-7500

Sipex Corporation reserves the right to make changes to any products described herein. Sipex does not assume any liability arising out of the application or use of any product or circuit described herein; neither does it convey any license under its patent rights nor the rights of others.