

NEC's 4 PIN SOP 1.1 Ω LOW ON-STATE RESISTANCE 1-CH OPTICAL COUPLED MOSFET

PS7200K-1A

FEATURES

- **1 CHANNEL TYPE:**
1a output
- **LOW ON-STATE RESISTANCE**
 $R_{ON} = 1.1 \Omega$ TYP
- **LOW C x R :**
 $C \times R = 10.5 \text{ pF} \cdot \Omega$
- **LOW OFF-STATE LEAKAGE CURRENT:**
 $I_{LOFF} = 0.03 \text{ nA}$ TYP
- **HIGH SPEED TURN-ON TIME:**
 $t_{ON} = 0.1 \text{ ms}$ TYP
- **DESIGNED FOR AC/DC SWITCHING LINE CHANGER**
- **SMALL AND THIN PACKAGE:**
4 pin SOP, Height = 2.1 mm
- **HIGH ISOLATION VOLTAGE:**
 $BV = 1500 \text{ Vr.m.s.}$
- **LOW OFFSET VOLTAGE**
- **AVAILABLE ON TAPE AND REEL**

DESCRIPTION

NEC's PS7200K-1A is a low output capacitance solid state relay containing GaAs LEDs on the light emitting side (input side) and MOSFETs on the output side. It is suitable for high frequency signal control, due to its low C x R, low on-state resistance, and low off-state leakage current.

APPLICATIONS

- **MEASUREMENT EQUIPMENT**

ELECTRICAL CHARACTERISTICS ($T_A = 25^\circ\text{C}$)

		PART NUMBER	PS7200K-1A			
	SYMBOLS	PARAMETERS	UNITS	MIN	TYP	MAX
Diode	V_F	Forward Voltage, $I_F = 10 \text{ mA}$	V		1.2	1.4
	I_R	Reverse Current, $V_R = 5 \text{ V}$	μA			5.0
MOS FET	I_{LOFF}	Off-State Leakage Current, $V_D = 40 \text{ V}$	nA		0.03	10
	C_{out}	Output Capacitance, $V_D = 0 \text{ V}$, $f = 1 \text{ MHz}$	pF		9.6	
Coupled	I_{Fon}	LED On-state Current $I_L = 200 \text{ mA}$	mA			2.0
	R_{ON1}	On-State Resistance	$I_F = 10 \text{ mA}$, $I_L = 10 \text{ mA}$		1.1	2.0
	t_{ON}	Turn-on Time, $I_F = 10 \text{ mA}$, $V_O = 5 \text{ V}$, $PW \geq 10 \text{ ms}$	ms		0.1	0.5
	t_{OFF}	Turn-off Time, $I_F = 10 \text{ mA}$, $V_O = 5 \text{ V}$, $PW \geq 10 \text{ ms}$	ms		0.1	1.0
	R_{I-O}	Isolation Resistance, $V_{I-O} = 1.0 \text{ kVDC}$	Ω	10^9		
	C_{I-O}	Isolation Capacitance, $V = 0 \text{ V}$, $f = 1 \text{ MHz}$	pF		0.3	

Notes:

1. Test Circuit for Switching Time:

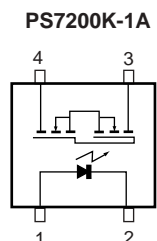
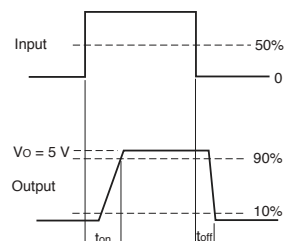
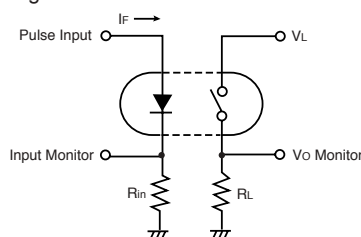

2. The turn-on time and turn-off time are specified as input-pulse width $\geq 10 \text{ ms}$. Be aware that when the device operates with an input-pulse width of under 10 ms, the turn-on time and turn-off time will increase.

PS7200K-1A

ABSOLUTE MAXIMUM RATINGS¹ (T_A = 25°C)

SYMBOLS	PARAMETERS	UNITS	RATINGS
Diode			
I _F	Forward Current (DC)	mA	50
V _R	Reverse Voltage	V	5
P _D	Power Dissipation	mW	50
I _{FP}	Peak Forward Current ²	A	1
MOSFET			
V _L	Break Down Voltage	V	40
I _L	Continuous Load Current	mA	200
I _{LP}	Pulse Load Current ³ AC/DC Connection	mA	400
P _D	Power Dissipation	mW	100
Coupled			
BV	Isolation Voltage ⁴	Vr.m.s.	1500
P _T	Total Power Dissipation	mW	150
T _A	Operating Ambient Temp.	°C	-40 to +85
T _{STG}	Storage Temperature	°C	-40 to +100

Notes:

- Operation in excess of any one of these parameters may result in permanent damage.
- PW = 100μs, Duty Cycle = 1%.
- PW = 100 ms, 1 shot.
- AC voltage for 1 minute at T_A = 25°C, RH = 60% between input and output.

RECOMMENDED OPERATING CONDITIONS (T_A = 25°C)

SYMBOLS	PARAMETERS	UNITS	MIN	TYP	MAX
I _F	LED Operating Current	mA	2	10	20
V _F	LED Off Voltage	V	0		0.5

TYPICAL PERFORMANCE CURVES (T_A = 25°C)

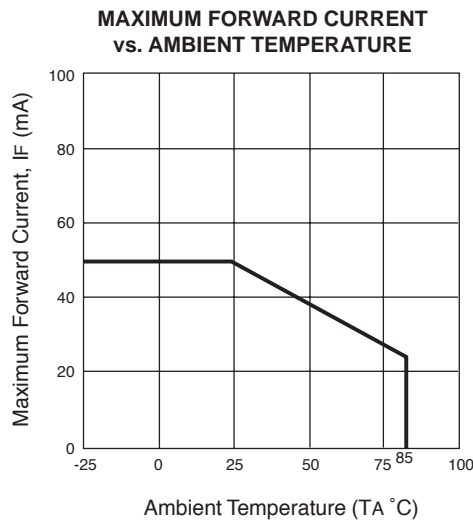

OUTLINE DIMENSIONS (Units in mm)

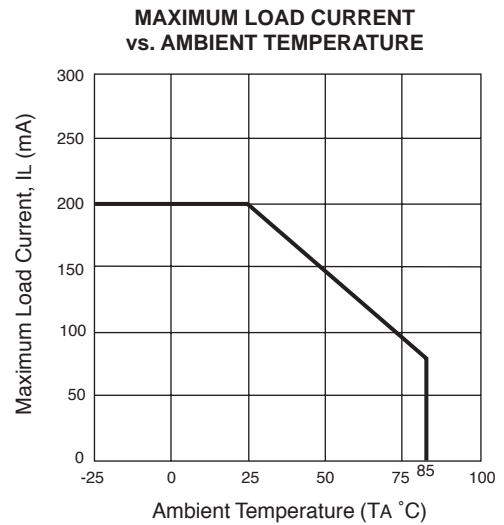
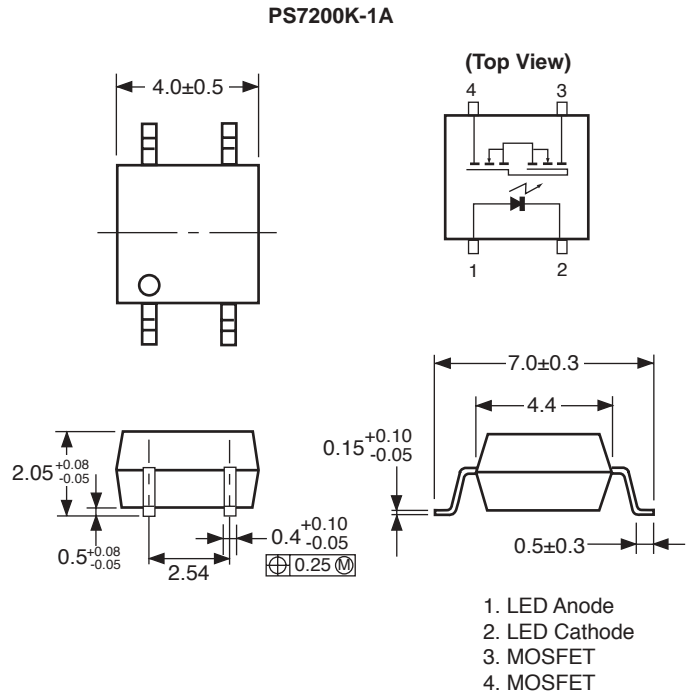

TYPICAL PERFORMANCE CURVES (TA = 25°C)

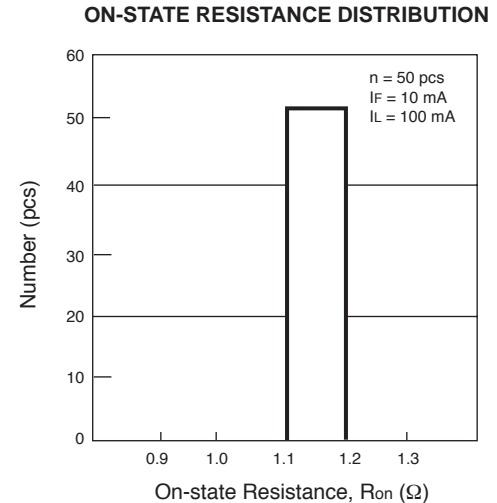
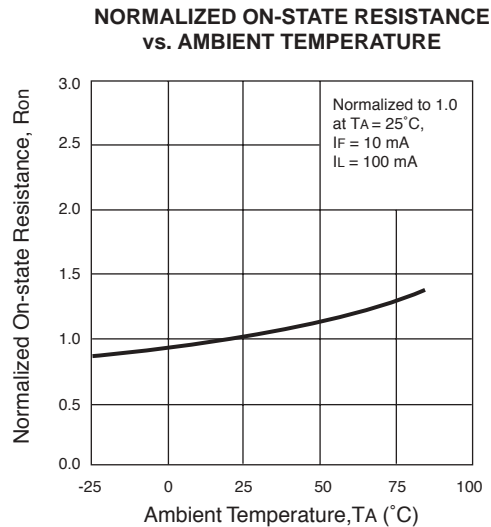
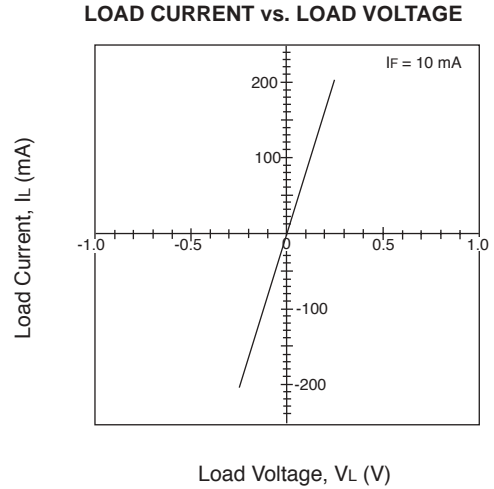
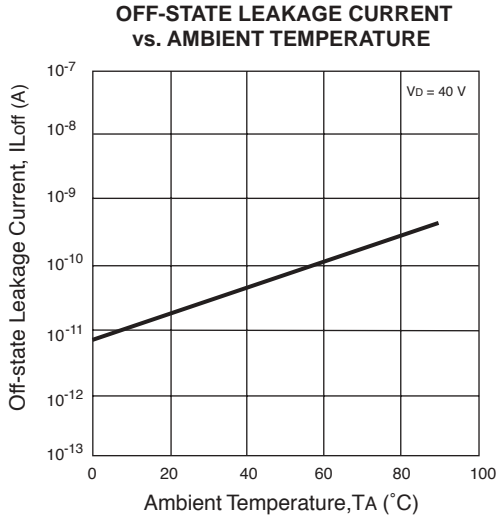
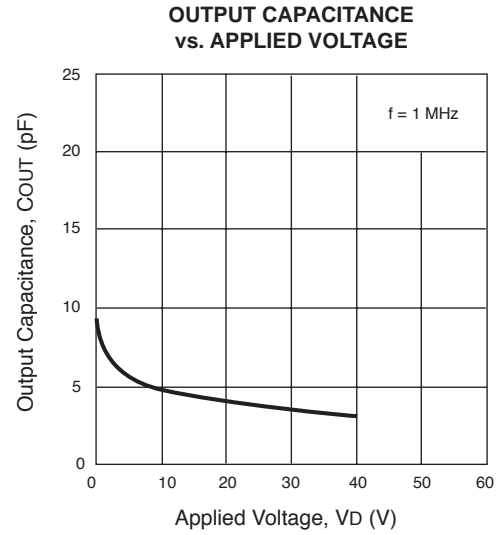
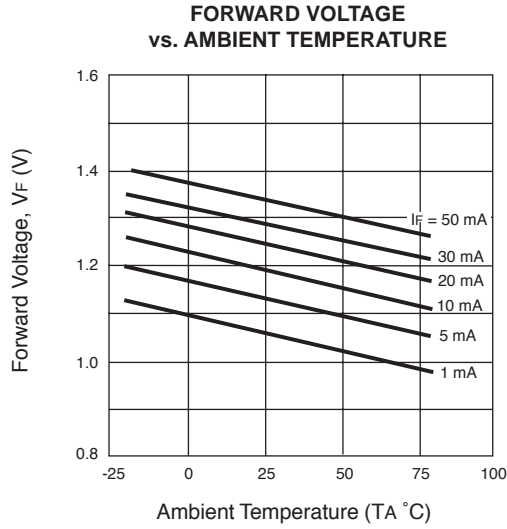

TYPICAL PERFORMANCE CURVES (TA = 25°C)

TURN-ON TIME vs. FORWARD CURRENT

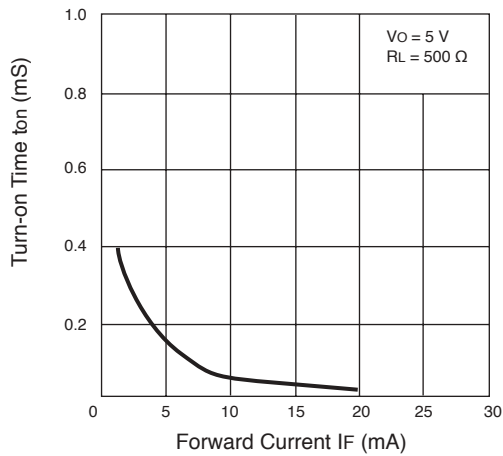

TURN-OFF TIME vs. FORWARD CURRENT



TURN-ON TIME DISTRIBUTION

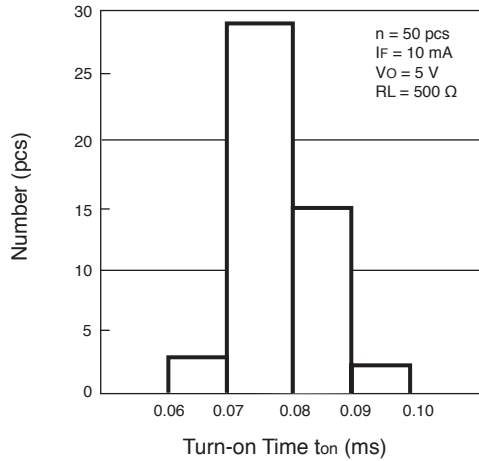

TURN-OFF TIME DISTRIBUTION

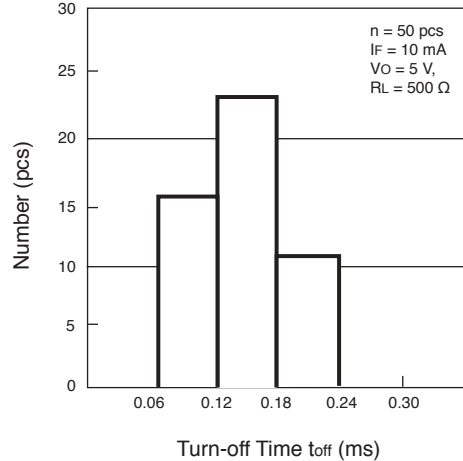

NORMALIZED TURN-ON TIME vs. AMBIENT TEMPERATURE

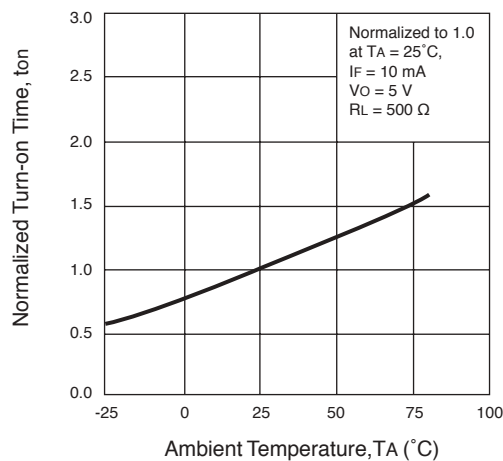

NORMALIZED TURN-OFF TIME vs. AMBIENT TEMPERATURE

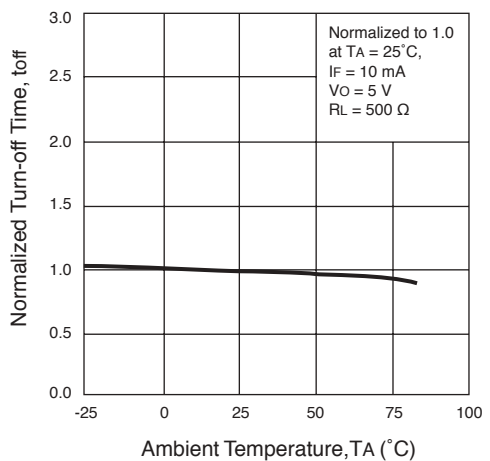

TAPING SPECIFICATIONS (Units in mm)

Tape Outline and Dimensions

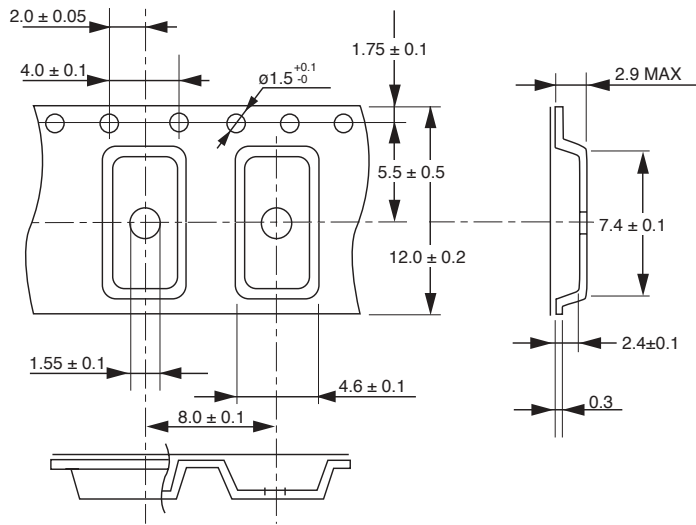

Tape Direction

PS7200R-1A-E3

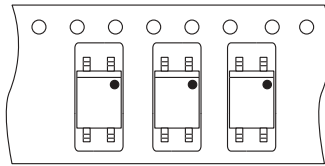

PS7200R-1A-E4

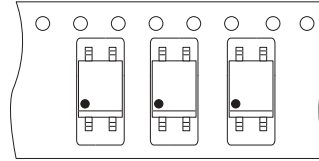

Reel Outline and Dimensions

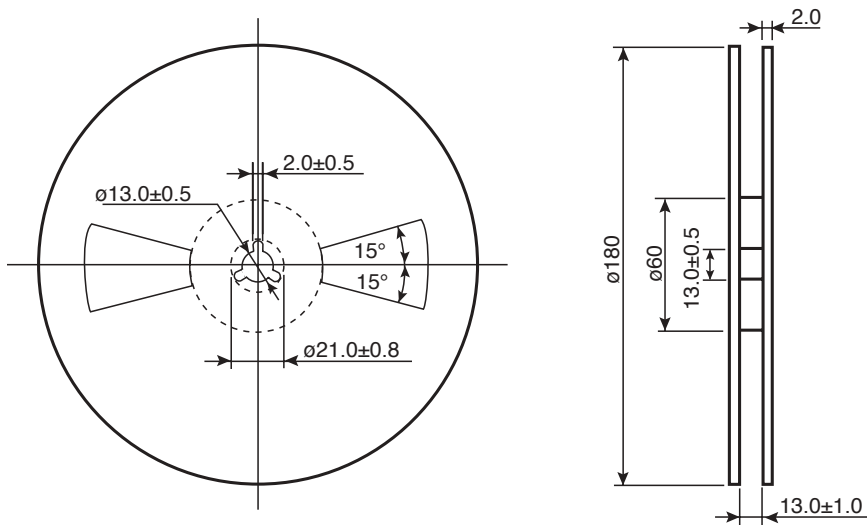

Packing: 900 pcs/reel

TAPING SPECIFICATIONS (Units in mm)

Tape Outline and Dimensions

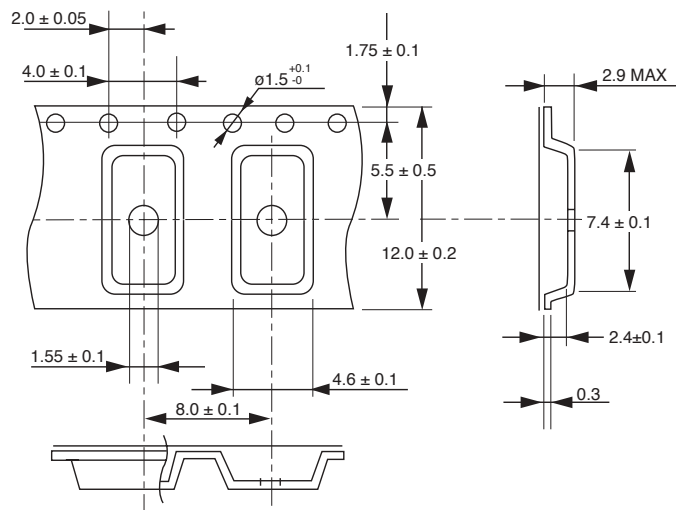

Tape Direction

PS7200R-1A-F3

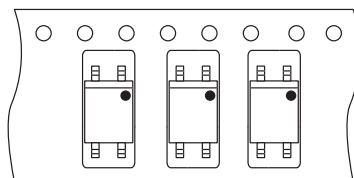

PS7200R-1A-F4

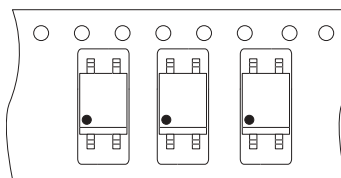

Reel Outline and Dimensions

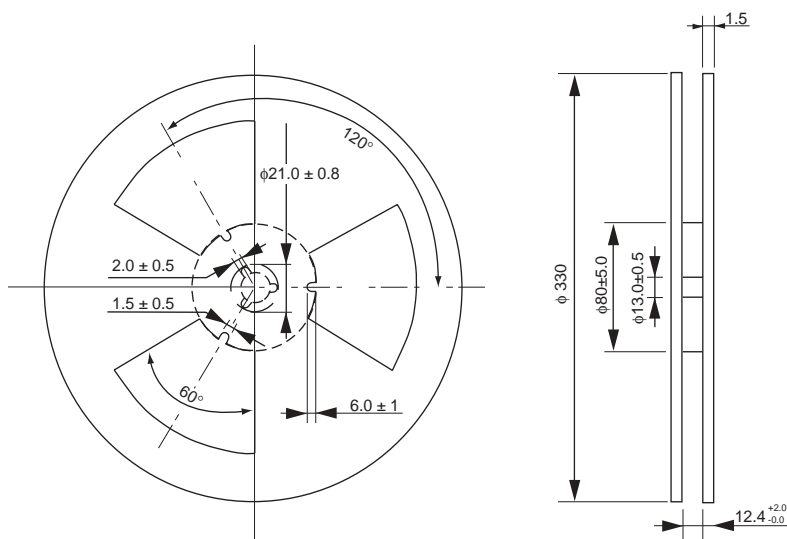

RECOMMENDED SOLDERING CONDITIONS

(1) Infrared reflow soldering

- Peak reflow temperature 235 °C or below (package surface temperature)
- Time of temperature higher than 210 °C 30 seconds or less
- Number of reflows Two
- Flux Rosin flux containing small amount of chlorine
(The flux with a maximum chlorine content of 0.2 Wt % is recommended.)

Recommended Temperature Profile of Infrared Reflow

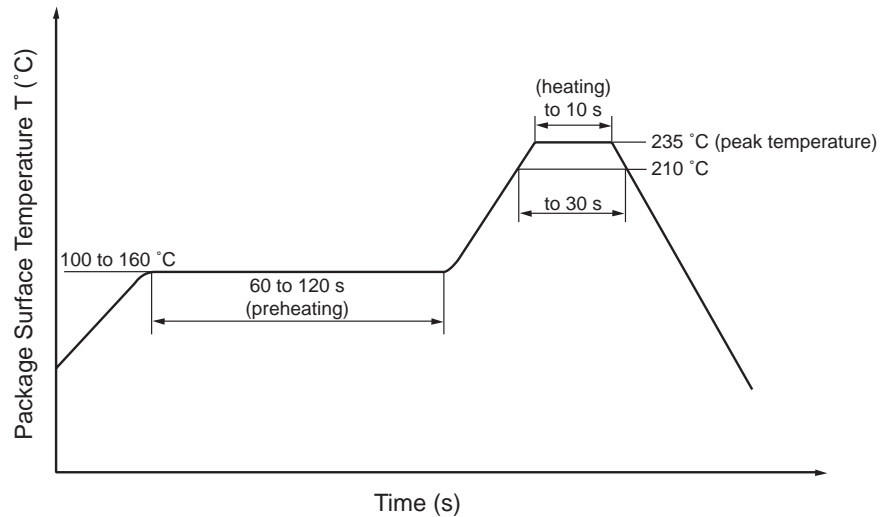

(2) Dip soldering

- Temperature 260 °C or below (molten solder temperature)
- Time 10 seconds or less
- Preheating conditions 100°C or below (package surface temperature)
- Number of times One
- Flux Rosin flux containing small amount of chlorine
(The flux with a maximum chlorine content of 0.2 Wt % is recommended.)

(3) Cautions

- Fluxes Avoid removing the residual flux with freon-based and chlorine-based cleaning solvent.

Life Support Applications

These NEC products are not intended for use in life support devices, appliances, or systems where the malfunction of these products can reasonably be expected to result in personal injury. The customers of CEL using or selling these products for use in such applications do so at their own risk and agree to fully indemnify CEL for all damages resulting from such improper use or sale.

CEL California Eastern Laboratories, Your source for NEC RF, Microwave, Optoelectronic, and Fiber Optic Semiconductor Devices.
4590 Patrick Henry Drive • Santa Clara, CA 95054-1817 • (408) 988-3500 • FAX (408) 988-0279 • www.cel.com

DATA SUBJECT TO CHANGE WITHOUT NOTICE

11/11/2002