

IRF241, IRF243

File Number 1584

Power MOS Field-Effect Transistors

N-Channel Enhancement-Mode Power Field-Effect Transistors

16A and 18A, 150V
 $r_{DS(on)} = 0.18 \Omega$ and 0.22Ω

Features:

- SOA is power-dissipation limited
- Nanosecond switching speeds
- Linear transfer characteristics
- High input impedance
- Majority carrier device

The IRF241 and IRF243 are n-channel enhancement-mode silicon-gate power field-effect transistors designed for applications such as switching regulators, switching converters, motor drivers, relay drivers, and drivers for high-power bipolar switching transistors requiring high speed and low gate-drive power. These types can be operated directly from integrated circuits.

The IRF-types are supplied in the JEDEC TO-204AE steel package.

N-CHANNEL ENHANCEMENT MODE

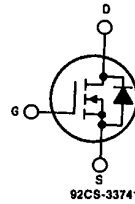

TERMINAL DIAGRAM

TERMINAL DESIGNATION

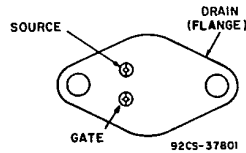

JEDEC TO-204AE

Absolute Maximum Ratings

Parameter	IRF241	IRF243	Units
V_{DS} Drain - Source Voltage ①	150	150	V
V_{DGR} Drain - Gate Voltage ($R_{GS} = 20 \text{ k}\Omega$) ②	150	150	V
$I_D @ T_C = 25^\circ\text{C}$ Continuous Drain Current	18	16	A
$I_D @ T_C = 100^\circ\text{C}$ Continuous Drain Current	11	10	A
I_{DM} Pulsed Drain Current ③	72	64	A
V_{GS} Gate - Source Voltage	± 20		V
$P_D @ T_C = 25^\circ\text{C}$ Max. Power Dissipation	125	(See Fig. 14)	W
Linear Derating Factor	1.0	(See Fig. 14)	W/ $^\circ\text{C}$
I_{LM} Inductive Current, Clamped	72	(See Fig. 15 and 16) $L = 100\mu\text{H}$	A
T_J Operating Junction and Storage Temperature Range	-55 to 150		$^\circ\text{C}$
T_{stg} Lead Temperature	300 (0.063 in. (1.6mm) from case for 10s)		$^\circ\text{C}$

IRF241, IRF243

Electrical Characteristics @T_C = 25°C (Unless Otherwise Specified)

Parameter	Type	Min.	Typ.	Max.	Units	Test Conditions
BVDSS Drain - Source Breakdown Voltage	IRF241 IRF243	150	-	-	V	V _{GS} = 0V I _D = 250μA
VGS(th) Gate Threshold Voltage	ALL	2.0	-	4.0	V	V _{DS} = V _{GS} , I _D = 250μA
IGSS Gate-Source Leakage Forward	ALL	-	-	100	nA	V _{GS} = 20V
IGSS Gate-Source Leakage Reverse	ALL	-	-	-100	nA	V _{GS} = -20V
IGSS Zero Gate Voltage Drain Current	ALL	-	-	250	μA	V _{DS} = Max. Rating, V _{GS} = 0V
		-	-	1000	μA	V _{DS} = Max. Rating x 0.8, V _{GS} = 0V, T _C = 125°C
ID(on) On-State Drain Current ②	IRF241 IRF243	18	-	-	A	V _{DS} > I _{D(on)} × R _{DS(on)} max., V _{GS} = 10V
RDS(on) Static Drain-Source On-State Resistance ②	IRF241 IRF243	-	0.14	0.18	Ω	V _{GS} = 10V, I _D = 10A
gfs Forward Transconductance ②	ALL	6.0	9.0	-	S (Ω)	V _{DS} > I _{D(on)} × R _{DS(on)} max., I _D = 10A
Ciss Input Capacitance	ALL	-	1275	1600	pF	V _{GS} = 0V, V _{DS} = 25V, f = 1.0 MHz
Coss Output Capacitance	ALL	-	500	750	pF	See Fig. 10
Crss Reverse Transfer Capacitance	ALL	-	160	300	pF	
tD(on) Turn-On Delay Time	ALL	-	16	30	ns	V _{DD} = 75V, I _D = 10A, Z _θ = 4.7Ω
tR Rise Time	ALL	-	27	60	ns	See Fig. 17
tD(off) Turn-Off Delay Time	ALL	-	40	80	ns	(MOSFET switching times are essentially independent of operating temperature)
tF Fall Time	ALL	-	31	60	ns	
QG Total Gate Charge (Gate-Source Plus Gate-Drain)	ALL	-	43	60	nC	V _{GS} = 10V, I _D = 22A, V _{DS} = 0.8 Max. Rating. See Fig. 18 for test circuit. (Gate charge is essentially independent of operating temperature)
QGS Gate-Source Charge	ALL	-	18	-	nC	
QGD Gate-Drain ("Miller") Charge	ALL	-	27	-	nC	
LD Internal Drain Inductance	ALL	-	5.0	-	nH	Measured between the contact screw on header that is closer to source and gate pins and center of die.
LS Internal Source Inductance	ALL	-	12.5	-	nH	Measured from the source pin, 6 mm (0.25 in.) from header and source bonding pad.

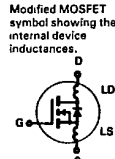

Thermal Resistance

RθJC Junction-to-Case	ALL	-	-	1.0	°C/W	
RθCS Case-to-Sink	ALL	-	0.1	-	°C/W	Mounting surface flat, smooth, and greased
RθJA Junction-to-Ambient	ALL	-	-	30	°C/W	Free Air Operation

Source-Drain Diode Ratings and Characteristics

IS Continuous Source Current (Body Diode)	IRF241 IRF243	-	-	18	A	Modified MOSFET symbol showing the integral reverse P-N junction rectifier.
ISM Pulse Source Current (Body Diode) ③	IRF241 IRF243	-	-	72 64	A	
VSD Diode Forward Voltage ②	IRF241 IRF243	-	-	2.0 1.9	V	T _C = 25°C, I _S = 18A, V _{GS} = 0V
t _{rr} Reverse Recovery Time	ALL	-	650	-	ns	T _J = 150°C, I _F = 18A, di/dt = 100A/μs
QRR Reverse Recovered Charge	ALL	-	4.1	-	μC	T _J = 150°C, I _F = 18A, di/dt = 100A/μs
t _{on} Forward Turn on Time	ALL	Intrinsic turn-on time is negligible. Turn-on speed is substantially controlled by L _G + L _D .				

① T_J = 25°C to 150°C. ② Pulse Test: Pulse width < 300μs, Duty Cycle < 2%. ③ Repetitive Rating: Pulse width limited by max. junction temperature. See Transient Thermal Impedance Curve (Fig. 5).

IRF241, IRF243

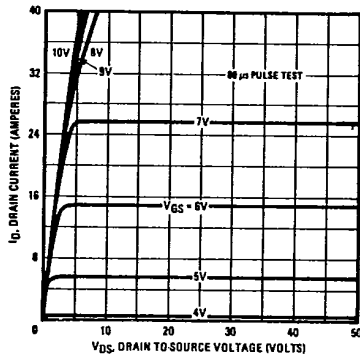

Fig. 1 - Typical Output Characteristics

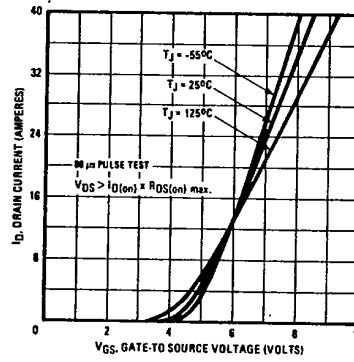

Fig. 2 - Typical Transfer Characteristics

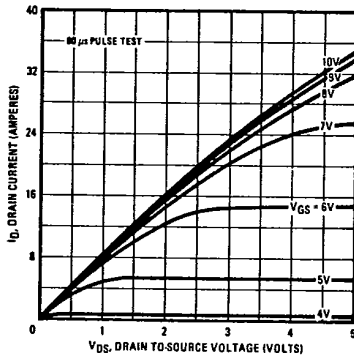

Fig. 3 - Typical Saturation Characteristics

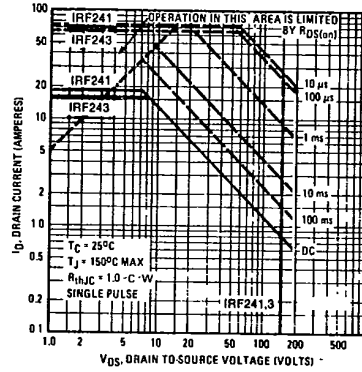

Fig. 4 - Maximum Safe Operating Area

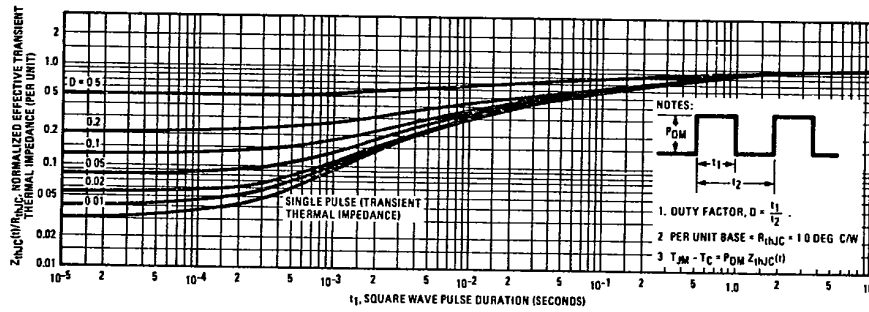

Fig. 5 - Maximum Effective Transient Thermal Impedance, Junction-to-Case Vs. Pulse Duration

IRF241, IRF243

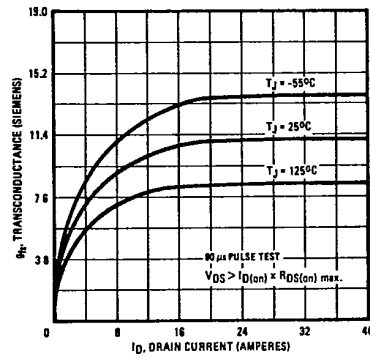

Fig. 6 - Typical Transconductance Vs. Drain Current

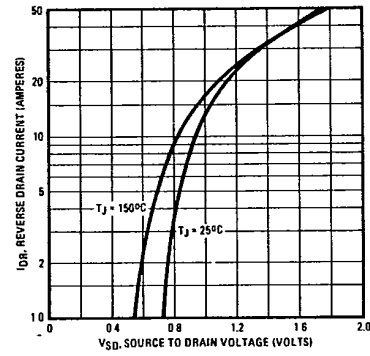

Fig. 7 - Typical Source-Drain Diode Forward Voltage

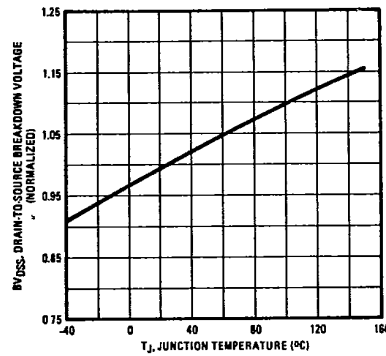

Fig. 8 - Breakdown Voltage Vs. Temperature

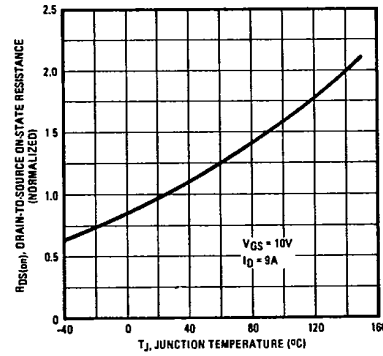

Fig. 9 - Normalized On-Resistance Vs. Temperature

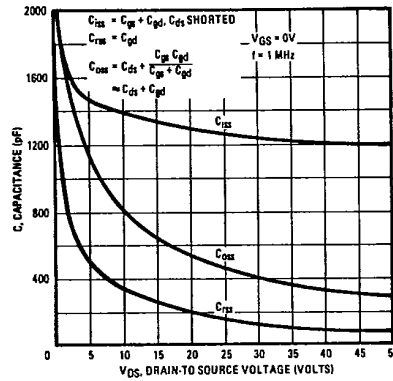

Fig. 10 - Typical Capacitance Vs. Drain-to-Source Voltage

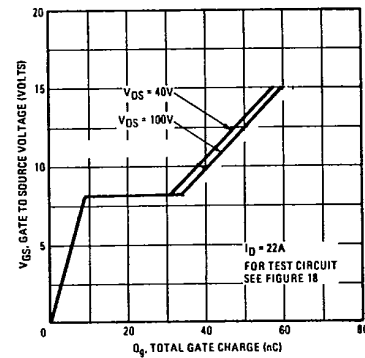

Fig. 11 - Typical Gate Charge Vs. Gate-to-Source Voltage

IRF241, IRF243

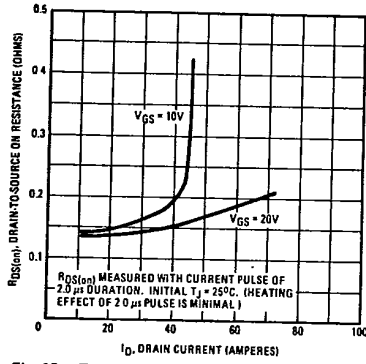

Fig. 12 - Typical On-Resistance Vs. Drain Current

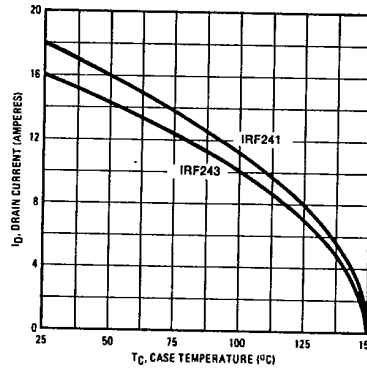

Fig. 13 - Maximum Drain Current Vs. Case Temperature

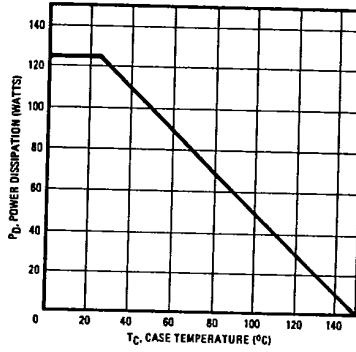

Fig. 14 - Power Vs. Temperature Derating Curve

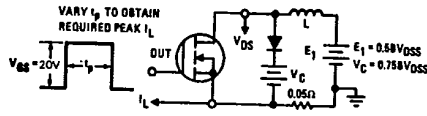

Fig. 15 - Clamped Inductive Test Circuit

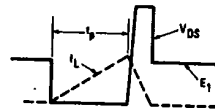

Fig. 16 - Clamped Inductive Waveforms

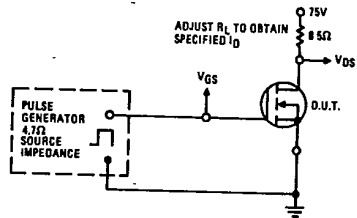

Fig. 17 - Switching Time Test Circuit

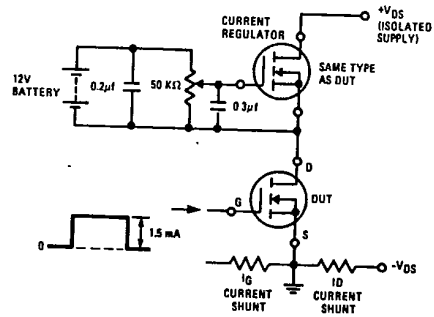

Fig. 18 - Gate Charge Test Circuit