

DATA SHEET

74HC154; 74HCT154 4-to-16 line decoder/demultiplexer

Product specification
Supersedes data of 2004 Oct 05

2004 Oct 12

4-to-16 line decoder/demultiplexer

74HC154; 74HCT154

FEATURES

- 16-line demultiplexing capability
- Decodes 4 binary-coded inputs into one 16 mutually exclusive outputs
- Complies with JEDEC standard no. 8-1 B
- ESD protection:
HBM EIA/JESD22-A114-B exceeds 2000 V
MM EIA/JESD22-A115-A exceeds 200 V.
- Specified from $-40\text{ }^{\circ}\text{C}$ to $+85\text{ }^{\circ}\text{C}$ and $-40\text{ }^{\circ}\text{C}$ to $+125\text{ }^{\circ}\text{C}$.

DESCRIPTION

The 74HC154; 74HCT154 are high-speed Si-gate CMOS devices and are pin compatible with low power Schottky TTL (LSTTL). They are specified in compliance with JEDEC standard no. 7A.

The 74HC154; 74HCT154 decoders accept four active HIGH binary address inputs and provide 16 mutually exclusive active LOW outputs. The two-input enable gate can be used to strobe the decoder to eliminate the normal decoding "glitches" on the outputs, or can be used for the expansion of the decoder.

The enable gate has two ANDed inputs which must be LOW to enable the outputs.

The 74HC154; 74HCT154 can be used as a 1-to-16 demultiplexer by using one of the enable inputs as the multiplexed data input.

When the other enable input is LOW, the addressed output will follow the state of the applied data.

QUICK REFERENCE DATA

GND = 0 V; $T_{\text{amb}} = 25\text{ }^{\circ}\text{C}$; $t_r = t_f = 6\text{ ns}$.

SYMBOL	PARAMETER	CONDITIONS	TYPICAL		UNIT
			74HC154	74HCT154	
$t_{\text{PHL}}/t_{\text{PLH}}$	propagation delay $A_n, \overline{E_n}$ to $\overline{Y_n}$	$C_L = 15\text{ pF}$; $R_L = 1\text{ k}\Omega$; $V_{\text{CC}} = 5\text{ V}$	11	13	ns
C_I	input capacitance		3.5	3.5	pF
C_{PD}	power dissipation capacitance per gate	notes 1 and 2	60	60	pF

Notes

1. C_{PD} is used to determine the dynamic power dissipation (P_D in μW).

$$P_D = C_{\text{PD}} \times V_{\text{CC}}^2 \times f_i \times N + \Sigma(C_L \times V_{\text{CC}}^2 \times f_o) \text{ where:}$$

f_i = input frequency in MHz;

f_o = output frequency in MHz;

C_L = output load capacitance in pF;

V_{CC} = supply voltage in Volts;

N = total load switching outputs;

$\Sigma(C_L \times V_{\text{CC}}^2 \times f_o)$ = sum of the outputs.

2. For 74HC154 the condition is $V_I = \text{GND}$ to V_{CC}
For 74HCT154 the condition is $V_I = \text{GND}$ to $V_{\text{CC}} - 1.5\text{ V}$.

4-to-16 line decoder/demultiplexer

74HC154; 74HCT154

FUNCTION TABLE

See note 1.

INPUT						OUTPUT																		
$\overline{E0}$	$\overline{E1}$	A0	A1	A2	A3	$\overline{Y0}$	$\overline{Y1}$	$\overline{Y2}$	$\overline{Y3}$	$\overline{Y4}$	$\overline{Y6}$	$\overline{Y7}$	$\overline{Y8}$	$\overline{Y2}$	$\overline{Y9}$	$\overline{Y10}$	$\overline{Y11}$	$\overline{Y12}$	$\overline{Y13}$	$\overline{Y14}$	$\overline{Y15}$			
H	H	X	X	X	X	H	H	H	H	H	H	H	H	H	H	H	H	H	H	H	H	H		
H	L	X	X	X	X	H	H	H	H	H	H	H	H	H	H	H	H	H	H	H	H	H		
L	H	X	X	X	X	H	H	H	H	H	H	H	H	H	H	H	H	H	H	H	H	H		
L	L	L	L	L	L	L	H	H	H	H	H	H	H	H	H	H	H	H	H	H	H	H		
		H	L	L	L	H	L	H	H	H	H	H	H	H	H	H	H	H	H	H	H	H	H	
		L	H	L	L	H	H	L	H	H	H	H	H	H	H	H	H	H	H	H	H	H	H	
		H	H	L	L	H	H	H	H	L	H	H	H	H	H	H	H	H	H	H	H	H	H	
		L	L	H	L	H	H	H	H	L	H	H	H	H	H	H	H	H	H	H	H	H	H	
		H	L	H	L	H	H	H	H	H	L	H	H	H	H	H	H	H	H	H	H	H	H	H
		L	H	H	L	H	H	H	H	H	H	L	H	H	H	H	H	H	H	H	H	H	H	H
		H	H	H	L	H	H	H	H	H	H	H	H	H	L	H	H	H	H	H	H	H	H	H
		L	L	L	H	H	H	H	H	H	H	H	H	H	L	H	H	H	H	H	H	H	H	H
		H	L	L	H	H	H	H	H	H	H	H	H	H	H	L	H	H	H	H	H	H	H	H
		L	H	L	H	H	H	H	H	H	H	H	H	H	H	H	L	H	H	H	H	H	H	H
		H	H	L	H	H	H	H	H	H	H	H	H	H	H	H	H	L	H	H	H	H	H	H
		L	L	H	H	H	H	H	H	H	H	H	H	H	H	H	H	H	L	H	H	H	H	H
		H	L	H	H	H	H	H	H	H	H	H	H	H	H	H	H	H	H	L	H	H	H	H
		L	H	H	H	H	H	H	H	H	H	H	H	H	H	H	H	H	H	H	H	L	H	H
		H	H	H	H	H	H	H	H	H	H	H	H	H	H	H	H	H	H	H	H	H	H	L

Note

1. H = HIGH voltage level
L = LOW voltage level
X = don't care.

4-to-16 line decoder/demultiplexer

74HC154; 74HCT154

ORDERING INFORMATION

TYPE NUMBER	TEMPERATURE RANGE	PACKAGE			
		PINS	PACKAGE	MATERIAL	CODE
74HC154N	-40 °C to +125 °C	24	DIP24	plastic	SOT101-1
74HCT154N	-40 °C to +125 °C	24	DIP24	plastic	SOT101-1
74HC154D	-40 °C to +125 °C	24	SO24	plastic	SOT137-1
74HCT154D	-40 °C to +125 °C	24	SO24	plastic	SOT137-1
74HC154DB	-40 °C to +125 °C	24	SSOP24	plastic	SOT340-1
74HCT154DB	-40 °C to +125 °C	24	SSOP24	plastic	SOT340-1
74HC154PW	-40 °C to +125 °C	24	TSSOP24	plastic	SOT355-1
74HCT154PW	-40 °C to +125 °C	24	TSSOP24	plastic	SOT355-1
74HC154BQ	-40 °C to +125 °C	24	DHVQFN24	plastic	SOT815-1
74HCT154BQ	-40 °C to +125 °C	24	DHVQFN24	plastic	SOT815-1

PINNING

PIN	SYMBOL	DESCRIPTION
1	$\overline{Y0}$	data output (active LOW)
2	$\overline{Y1}$	data output (active LOW)
3	$\overline{Y2}$	data output (active LOW)
4	$\overline{Y3}$	data output (active LOW)
5	$\overline{Y4}$	data output (active LOW)
6	$\overline{Y5}$	data output (active LOW)
7	$\overline{Y6}$	data output (active LOW)
8	$\overline{Y7}$	data output (active LOW)
9	$\overline{Y8}$	data output (active LOW)
10	$\overline{Y9}$	data output (active LOW)
11	$\overline{Y10}$	data output (active LOW)
12	GND	ground (0 V)
13	$\overline{Y11}$	data output (active LOW)
14	$\overline{Y12}$	data output (active LOW)
15	$\overline{Y13}$	data output (active LOW)
16	$\overline{Y14}$	data output (active LOW)
17	$\overline{Y15}$	data output (active LOW)
18	$\overline{E0}$	enable input
19	$\overline{E1}$	enable input
20	A3	data input
21	A2	data input
22	A1	data input
23	A0	data input
24	V _{CC}	positive supply voltage

4-to-16 line decoder/demultiplexer

74HC154; 74HCT154

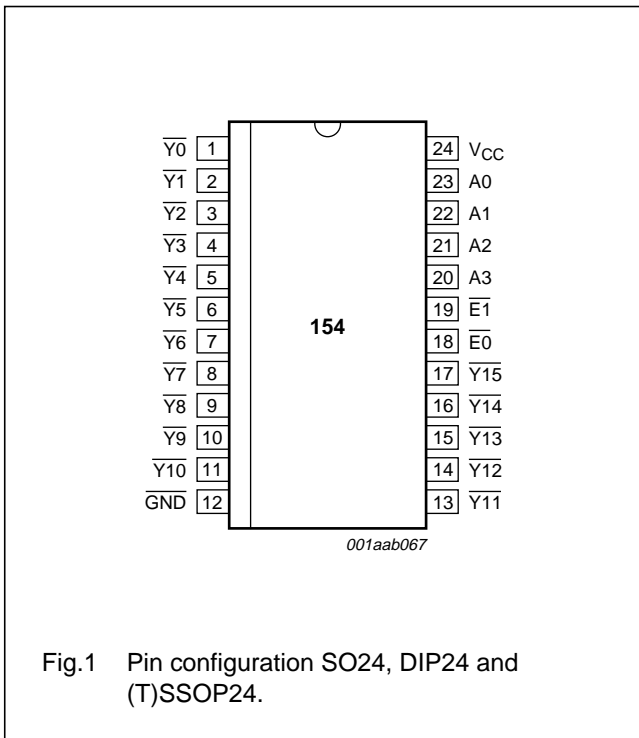

Fig.1 Pin configuration SO24, DIP24 and (T)SSOP24.

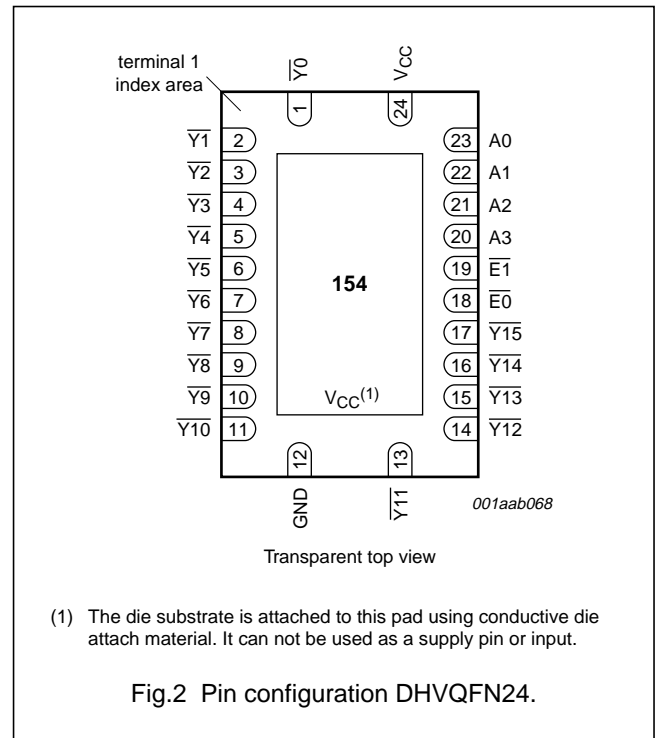

Fig.2 Pin configuration DHVQFN24.

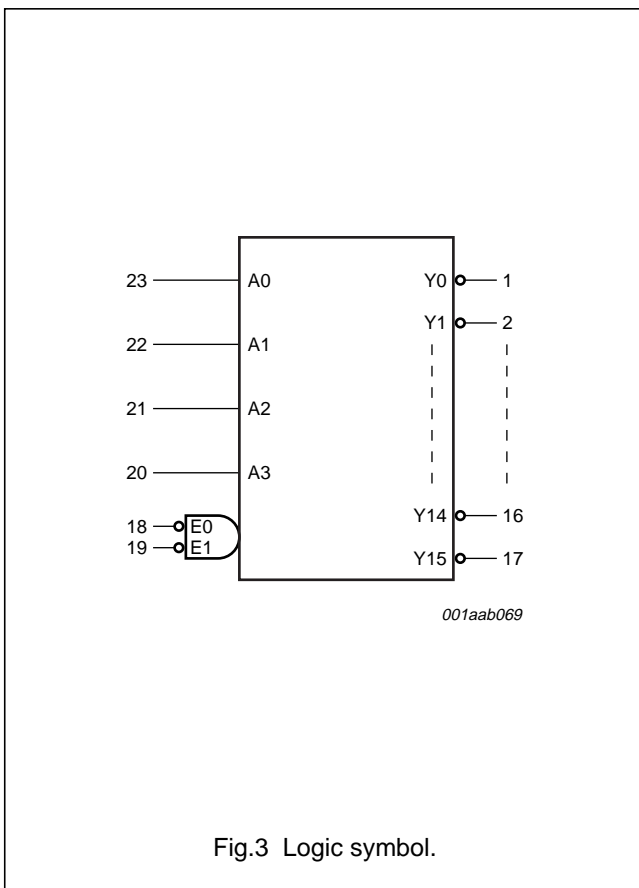

Fig.3 Logic symbol.

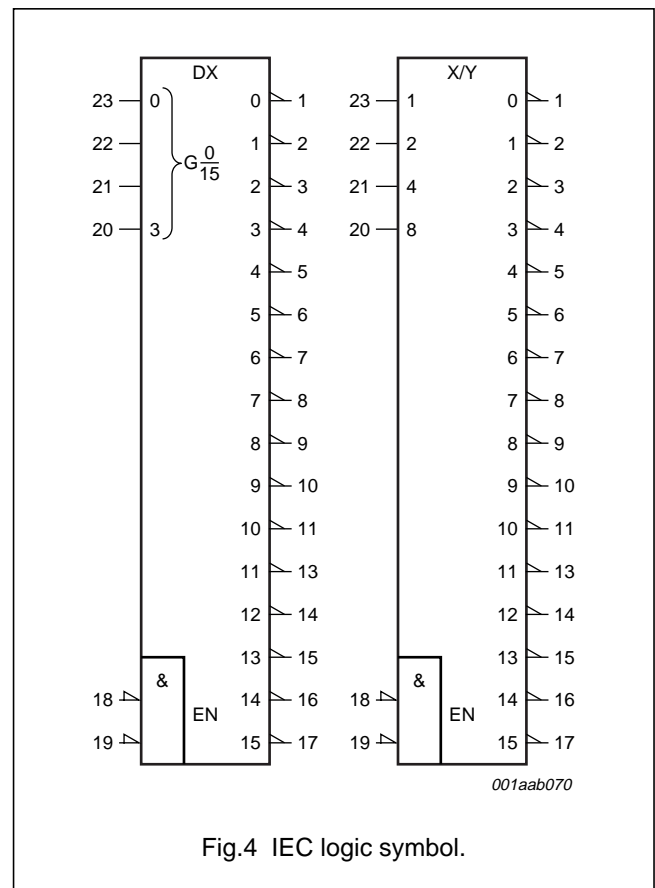

Fig.4 IEC logic symbol.

4-to-16 line decoder/demultiplexer

74HC154; 74HCT154

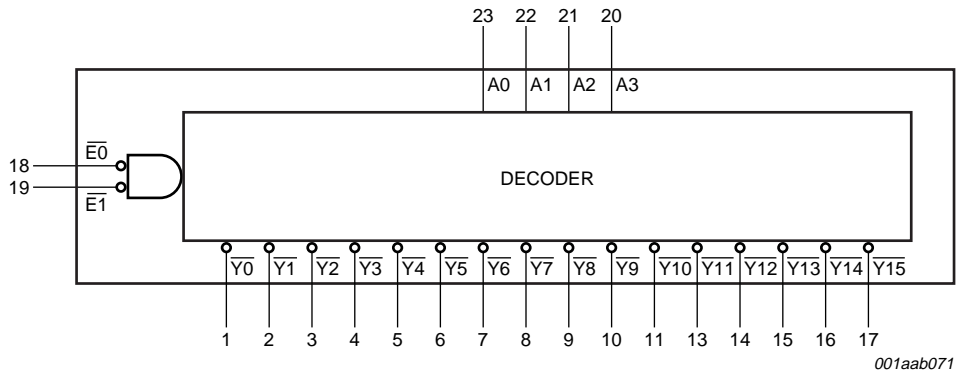

Fig.5 Functional diagram.

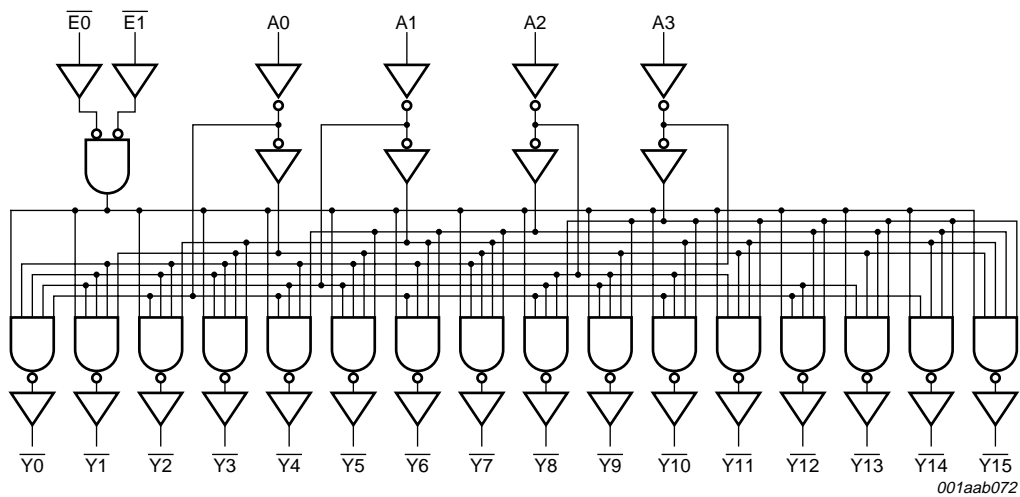

Fig.6 Logic diagram.

4-to-16 line decoder/demultiplexer

74HC154; 74HCT154

RECOMMENDED OPERATING CONDITIONS

SYMBOL	PARAMETER	CONDITIONS	74HC154			74HCT154			UNIT
			MIN.	TYP.	MAX.	MIN.	TYP.	MAX.	
V_{CC}	supply voltage		2.0	5.0	6.0	4.5	5.0	5.5	V
V_I	input voltage		0	–	V_{CC}	0	–	V_{CC}	V
V_O	output voltage		0	–	V_{CC}	0	–	V_{CC}	V
T_{amb}	ambient temperature		–40	+25	+125	–40	+25	+125	°C
t_r, t_f	input rise and fall times	$V_{CC} = 2.0\text{ V}$	–	–	1000	–	–	–	ns
		$V_{CC} = 4.5\text{ V}$	–	6.0	500	–	6.0	500	ns
		$V_{CC} = 6.0\text{ V}$	–	–	400	–	–	–	ns

LIMITING VALUES

In accordance with the Absolute Maximum Rating System (IEC 60134); voltages are referenced to GND (ground = 0 V).

SYMBOL	PARAMETER	CONDITIONS	MIN.	MAX.	UNIT
V_{CC}	supply voltage		–0.5	+7.0	V
I_{IK}	input diode current	$V_I < -0.5\text{ V}$ or $V_I > V_{CC} + 0.5\text{ V}$; note 1	–	±20	mA
I_{OK}	output diode current	$V_O < -0.5\text{ V}$ or $V_O > V_{CC} + 0.5\text{ V}$; note 1	–	±20	mA
I_O	output source or sink current	$-0.5\text{ V} < V_O < V_{CC} + 0.5\text{ V}$; note 1	–	±25	mA
I_{CC}, I_{GND}	V_{CC} or GND current	note 1	–	±50	mA
T_{stg}	storage temperature		–65	+150	°C
P_{tot}	power dissipation	$T_{amb} = -40\text{ °C}$ to $+125\text{ °C}$; note 2	–	300	mW

Notes

- The input and output voltage ratings may be exceeded if the input and output current ratings are observed.
- For DIP24 packages: above 70 °C the value of P_{tot} derates linearly with 12 mW/K.
For SO24 packages: above 70 °C the value of P_{tot} derates linearly with 8 mW/K.
For SSOP24 and TSSOP24 packages: above 60 °C the value of P_{tot} derates linearly with 5.5 mW/K.
For DHVQFN24 packages: above 60 °C the value of P_{tot} derates linearly with 4.5 mW/K.

4-to-16 line decoder/demultiplexer

74HC154; 74HCT154

DC CHARACTERISTICS

Type 74HC154

At recommended operating conditions; voltages are referenced to GND (ground = 0 V).

SYMBOL	PARAMETER	CONDITIONS		MIN.	TYP.	MAX.	UNIT
		OTHER	V _{CC} (V)				
T _{amb} = 25 °C							
V _{IH}	HIGH-level input voltage		2.0	1.5	1.2	–	V
			4.5	3.15	2.4	–	V
			6.0	4.2	3.2	–	V
V _{IL}	LOW-level input voltage		2.0	–	0.8	0.5	V
			4.5	–	2.1	1.35	V
			6.0	–	2.8	1.8	V
V _{OH}	HIGH-level output voltage	V _I = V _{IH} or V _{IL} I _O = –20 µA	2.0	1.9	2.0	–	V
		I _O = –20 µA	4.5	4.4	4.5	–	V
		I _O = –20 µA	6.0	5.9	6.0	–	V
		I _O = –4.0 mA	4.5	3.98	4.32	–	V
		I _O = –5.2 mA	6.0	5.48	5.81	–	V
V _{OL}	LOW-level output voltage	V _I = V _{IH} or V _{IL} I _O = 20 µA	2.0	–	0	0.1	V
		I _O = 20 µA	4.5	–	0	0.1	V
		I _O = 20 µA	6.0	–	0	0.1	V
		I _O = 4.0 mA	4.5	–	0.15	0.26	V
		I _O = 5.2 mA	6.0	–	0.16	0.26	V
I _{LI}	input leakage current	V _I = V _{CC} or GND	6.0	–	–	±0.1	µA
I _{CC}	quiescent supply current	V _I = V _{CC} or GND; I _O = 0 A	6.0	–	–	8.0	µA

4-to-16 line decoder/demultiplexer

74HC154; 74HCT154

SYMBOL	PARAMETER	CONDITIONS		MIN.	TYP.	MAX.	UNIT
		OTHER	V _{CC} (V)				
T_{amb} = -40 °C to +85 °C							
V _{IH}	HIGH-level input voltage		2.0	1.5	-	-	V
			4.5	3.15	-	-	V
			6.0	4.2	-	-	V
V _{IL}	LOW-level input voltage		2.0	-	-	0.5	V
			4.5	-	-	1.35	V
			6.0	-	-	1.8	V
V _{OH}	HIGH-level output voltage	V _I = V _{IH} or V _{IL} I _O = -20 μA	2.0	1.9	-	-	V
		I _O = -20 μA	4.5	4.4	-	-	V
		I _O = -20 μA	6.0	5.9	-	-	V
		I _O = -4.0 mA	4.5	3.84	-	-	V
		I _O = -5.2 mA	6.0	5.34	-	-	V
V _{OL}	LOW-level output voltage	V _I = V _{IH} or V _{IL} I _O = 20 μA	2.0	-	-	0.1	V
		I _O = 20 μA	4.5	-	-	0.1	V
		I _O = 20 μA	6.0	-	-	0.1	V
		I _O = 4.0 mA	4.5	-	-	0.33	V
		I _O = 5.2 mA	6.0	-	-	0.33	V
I _{LI}	input leakage current	V _I = V _{CC} or GND	6.0	-	-	±1.0	μA
I _{CC}	quiescent supply current	V _I = V _{CC} or GND; I _O = 0 A	6.0	-	-	80	μA

4-to-16 line decoder/demultiplexer

74HC154; 74HCT154

SYMBOL	PARAMETER	CONDITIONS		MIN.	TYP.	MAX.	UNIT
		OTHER	V _{CC} (V)				
T_{amb} = -40 °C to +125 °C							
V _{IH}	HIGH-level input voltage		2.0	1.5	–	–	V
			4.5	3.15	–	–	V
			6.0	4.2	–	–	V
V _{IL}	LOW-level input voltage		2.0	–	–	0.5	V
			4.5	–	–	1.35	V
			6.0	–	–	1.8	V
V _{OH}	HIGH-level output voltage	V _I = V _{IH} or V _{IL} I _O = -20 μA	2.0	1.9	–	–	V
		I _O = -20 μA	4.5	4.4	–	–	V
		I _O = -20 μA	6.0	5.9	–	–	V
		I _O = -4.0 mA	4.5	3.7	–	–	V
		I _O = -5.2 mA	6.0	5.2	–	–	V
V _{OL}	LOW-level output voltage	V _I = V _{IH} or V _{IL} I _O = 20 μA	2.0	–	–	0.1	V
		I _O = 20 μA	4.5	–	–	0.1	V
		I _O = 20 μA	6.0	–	–	0.1	V
		I _O = 4.0 mA	4.5	–	–	0.4	V
		I _O = 5.2 mA	6.0	–	–	0.4	V
I _{LI}	input leakage current	V _I = V _{CC} or GND	6.0	–	–	±0.1	μA
I _{CC}	quiescent supply current	V _I = V _{CC} or GND; I _O = 0 A	6.0	–	–	160	μA

4-to-16 line decoder/demultiplexer

74HC154; 74HCT154

Type 74HCT154

At recommended operating conditions; voltages are referenced to GND (ground = 0 V).

SYMBOL	PARAMETER	CONDITIONS		MIN.	TYP.	MAX.	UNIT
		OTHER	V _{CC} (V)				
T_{amb} = 25 °C							
V _{IH}	HIGH-level input voltage		4.5 to 5.5	2.0	1.6	–	V
V _{IL}	LOW-level input voltage		4.5 to 5.5	–	1.2	0.8	V
V _{OH}	HIGH-level output voltage	V _I = V _{IH} or V _{IL} I _O = –20 µA	4.5	4.4	4.5	–	V
		I _O = –4 mA	4.5	3.98	4.32	–	V
V _{OL}	LOW-level output voltage	V _I = V _{IH} or V _{IL} I _O = 20 µA	4.5	–	0	0.1	V
		I _O = 4 mA	4.5	–	0.15	0.25	V
I _{LI}	input leakage current	V _I = V _{CC} or GND	5.5	–	–	±0.1	µA
I _{CC}	quiescent supply current	V _I = V _{CC} or GND; I _O = 0 A	5.5	–	–	8.0	µA
ΔI _{CC}	additional quiescent supply current per input	V _I = V _{CC} – 2.1 V; I _O = 0 A	4.5 to 5.5	–	–	360	µA
T_{amb} = –40 °C to +85 °C							
V _{IH}	HIGH-level input voltage		4.5 to 5.5	2.0	–	–	V
V _{IL}	LOW-level input voltage		4.5 to 5.5	–	–	0.8	V
V _{OH}	HIGH-level output voltage	V _I = V _{IH} or V _{IL} I _O = –20 µA	4.5	4.4	–	–	V
		I _O = –4 mA	4.5	3.84	–	–	V
V _{OL}	LOW-level output voltage	V _I = V _{IH} or V _{IL} I _O = 20 µA	4.5	–	–	0.1	V
		I _O = 4 mA	4.5	–	–	0.33	V
I _{LI}	input leakage current	V _I = V _{CC} or GND	5.5	–	–	±1.0	µA
I _{CC}	quiescent supply current	V _I = V _{CC} or GND; I _O = 0 A	5.5	–	–	80	µA
ΔI _{CC}	additional quiescent supply current per input	V _I = V _{CC} – 2.1 V; I _O = 0 A	4.5 to 5.5	–	–	450	µA

4-to-16 line decoder/demultiplexer

74HC154; 74HCT154

SYMBOL	PARAMETER	CONDITIONS		MIN.	TYP.	MAX.	UNIT
		OTHER	V _{CC} (V)				
T_{amb} = -40 °C to +125 °C							
V _{IH}	HIGH-level input voltage		4.5 to 5.5	2.0	–	–	V
V _{IL}	LOW-level input voltage		4.5 to 5.5	–	–	0.8	V
V _{OH}	HIGH-level output voltage	V _I = V _{IH} or V _{IL} I _O = -20 μA	4.5	4.4	–	–	V
		I _O = -4 mA	4.5	3.7	–	–	V
V _{OL}	LOW-level output voltage	V _I = V _{IH} or V _{IL} I _O = 20 μA	4.5	–	–	0.1	V
		I _O = 4 mA	4.5	–	–	0.4	V
I _{LI}	input leakage current	V _I = V _{CC} or GND	5.5	–	–	±1.0	μA
I _{CC}	quiescent supply current	V _I = V _{CC} or GND; I _O = 0 A	5.5	–	–	160	μA
ΔI _{CC}	additional quiescent supply current per input	V _I = V _{CC} - 2.1 V; I _O = 0 A	4.5 to 5.5	–	–	490	μA

4-to-16 line decoder/demultiplexer

74HC154; 74HCT154

AC CHARACTERISTICS

Type 74HC154

GND = 0 V; $t_r = t_f = 6$ ns; $C_L = 50$ pF.

SYMBOL	PARAMETER	TEST CONDITIONS		MIN.	TYP.	MAX.	UNIT
		WAVEFORMS	V_{CC} (V)				
$T_{amb} = 25$ °C							
t_{PHL}/t_{PLH}	propagation delay A_n to \overline{Y}_n	see Figs 7 and 9	2.0	–	36	150	ns
			4.5	–	13	30	ns
			6.0	–	10	26	ns
	propagation delay \overline{E}_n to \overline{Y}_n	see Figs 8 and 9	2.0	–	39	150	ns
			4.5	–	14	30	ns
			6.0	–	11	26	ns
t_{THL}/t_{TLH}	output transition time	see Figs 7, 8 and 9	2.0	–	19	75	ns
			4.5	–	7	15	ns
			6.0	–	6	13	ns
$T_{amb} = -40$ °C to $+85$ °C							
t_{PHL}/t_{PLH}	propagation delay A_n to \overline{Y}_n	see Figs 7 and 9	2.0	–	–	190	ns
			4.5	–	–	38	ns
			6.0	–	–	33	ns
	propagation delay \overline{E}_n to \overline{Y}_n	see Figs 8 and 9	2.0	–	–	190	ns
			4.5	–	–	38	ns
			6.0	–	–	33	ns
t_{THL}/t_{TLH}	output transition time	see Figs 7, 8 and 9	2.0	–	–	95	ns
			4.5	–	–	19	ns
			6.0	–	–	16	ns
$T_{amb} = -40$ °C to $+125$ °C							
t_{PHL}/t_{PLH}	propagation delay A_n to \overline{Y}_n	see Figs 7 and 9	2.0	–	–	225	ns
			4.5	–	–	45	ns
			6.0	–	–	38	ns
	propagation delay \overline{E}_n to \overline{Y}_n	see Figs 8 and 9	2.0	–	–	225	ns
			4.5	–	–	45	ns
			6.0	–	–	38	ns
t_{THL}/t_{TLH}	output transition time	see Figs 7, 8 and 9	2.0	–	–	110	ns
			4.5	–	–	22	ns
			6.0	–	–	19	ns

4-to-16 line decoder/demultiplexer

74HC154; 74HCT154

Type 74HCT154

GND = 0 V; $t_r = t_f = 6$ ns; $C_L = 50$ pF.

SYMBOL	PARAMETER	TEST CONDITIONS		MIN.	TYP.	MAX.	UNIT
		WAVEFORMS	V _{CC} (V)				
T_{amb} = 25 °C							
t _{PHL} /t _{PLH}	propagation delay A _n to \bar{Y}_n	see Figs 7 and 9	4.5	–	16	35	ns
	propagation delay \bar{E}_n to \bar{Y}_n	see Figs 8 and 9	4.5	–	15	32	ns
t _{THL} /t _{TLH}	output transition time	see Figs 7, 8 and 9	4.5	–	7	15	ns
T_{amb} = –40 °C to +85 °C							
t _{PHL} /t _{PLH}	propagation delay A _n to \bar{Y}_n	see Figs 7 and 9	4.5	–	–	44	ns
	propagation delay \bar{E}_n to \bar{Y}_n	see Figs 8 and 9	4.5	–	–	40	ns
t _{THL} /t _{TLH}	output transition time	see Figs 7, 8 and 9	4.5	–	–	19	ns
T_{amb} = –40 °C to +125 °C							
t _{PHL} /t _{PLH}	propagation delay A _n to \bar{Y}_n	see Figs 7 and 9	4.5	–	–	53	ns
	propagation delay \bar{E}_n to \bar{Y}_n	see Figs 8 and 9	4.5	–	–	48	ns
t _{THL} /t _{TLH}	output transition time	see Figs 7, 8 and 9	4.5	–	–	22	ns

AC WAVEFORMS

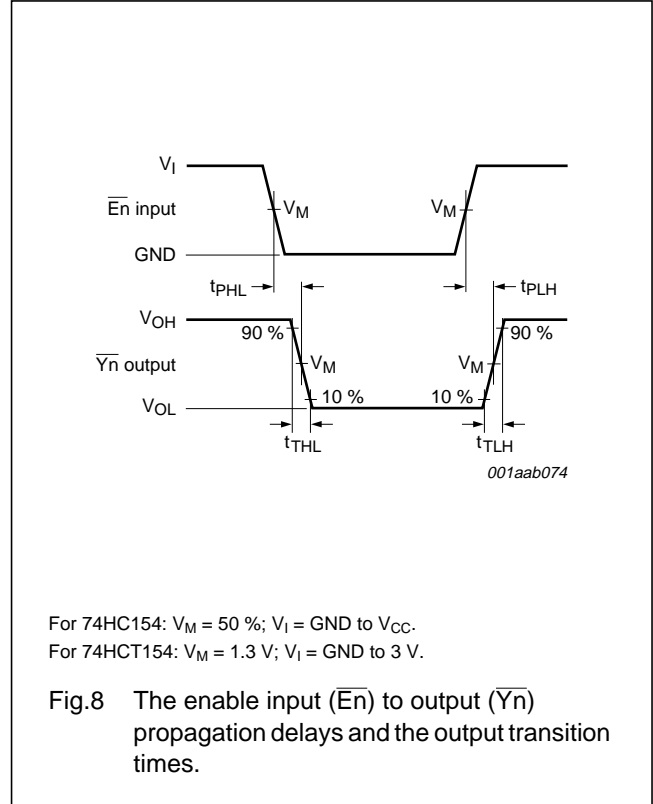
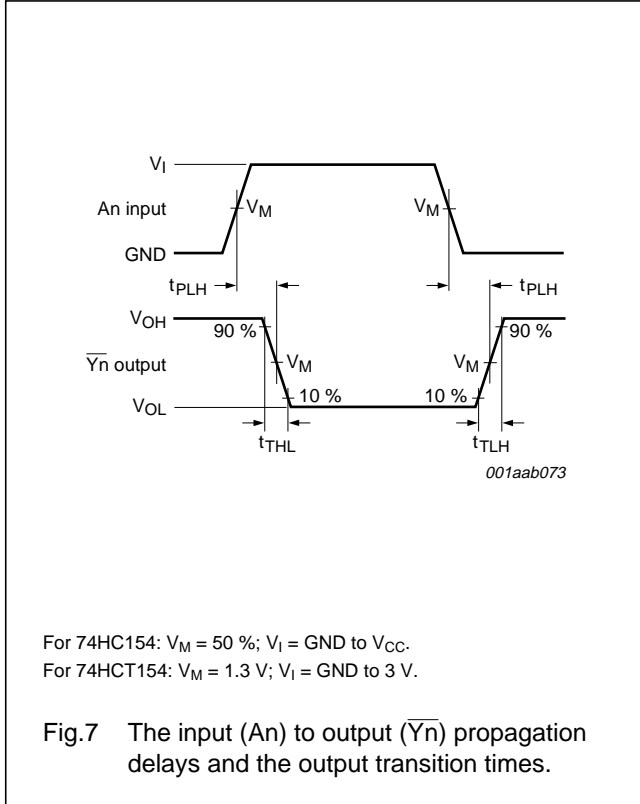

4-to-16 line decoder/demultiplexer

74HC154; 74HCT154

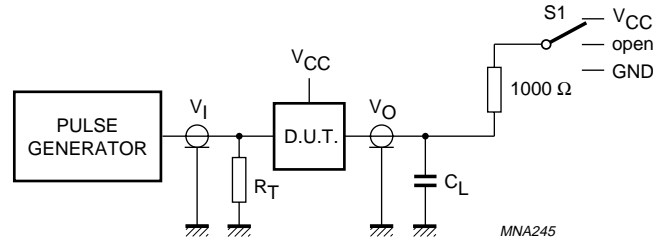

TEST	S1
t_{PLH}/t_{PHL}	open
t_{PLZ}/t_{PZL}	V _{CC}
t_{PHZ}/t_{PZH}	GND

Definitions for test circuit:
 C_L = Load capacitance including jig and probe capacitance.
 R_T = Termination resistance should be equal to the output impedance Z_o of the pulse generator.

Fig.9 Load circuitry for switching times.

APPLICATION DATA

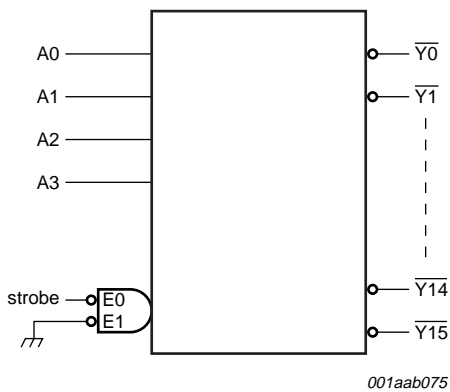

Fig.10 1-of-16 decoder; LOW level output selected.

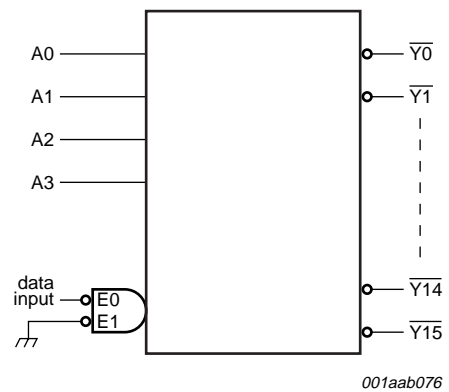

Fig.11 1-of-16 demultiplexer; logic level on selected outputs follow the logic level on the data input.

4-to-16 line decoder/demultiplexer

74HC154; 74HCT154

PACKAGE OUTLINES

DIP24: plastic dual in-line package; 24 leads (600 mil)

SOT101-1

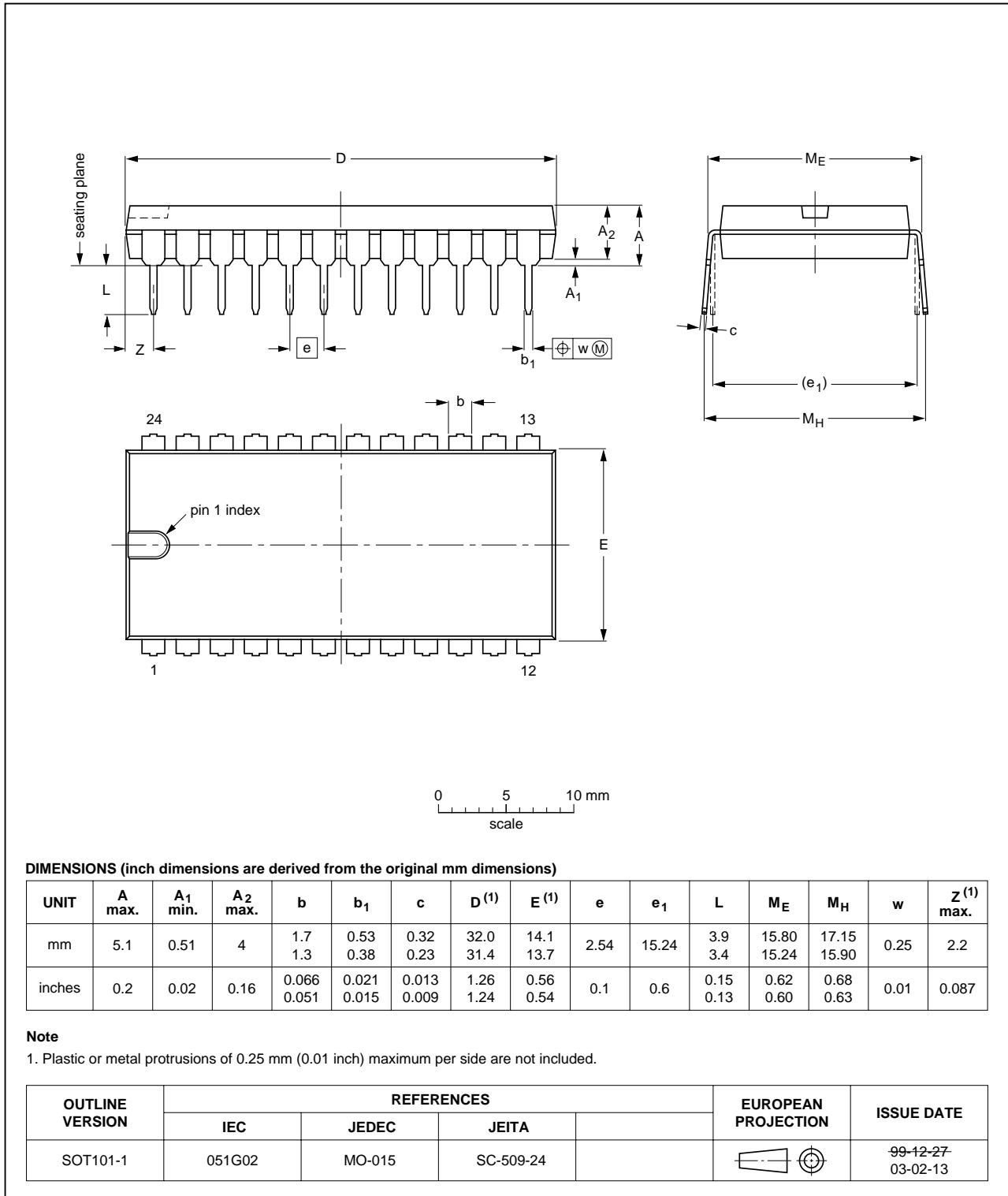

4-to-16 line decoder/demultiplexer

74HC154; 74HCT154

SO24: plastic small outline package; 24 leads; body width 7.5 mm

SOT137-1

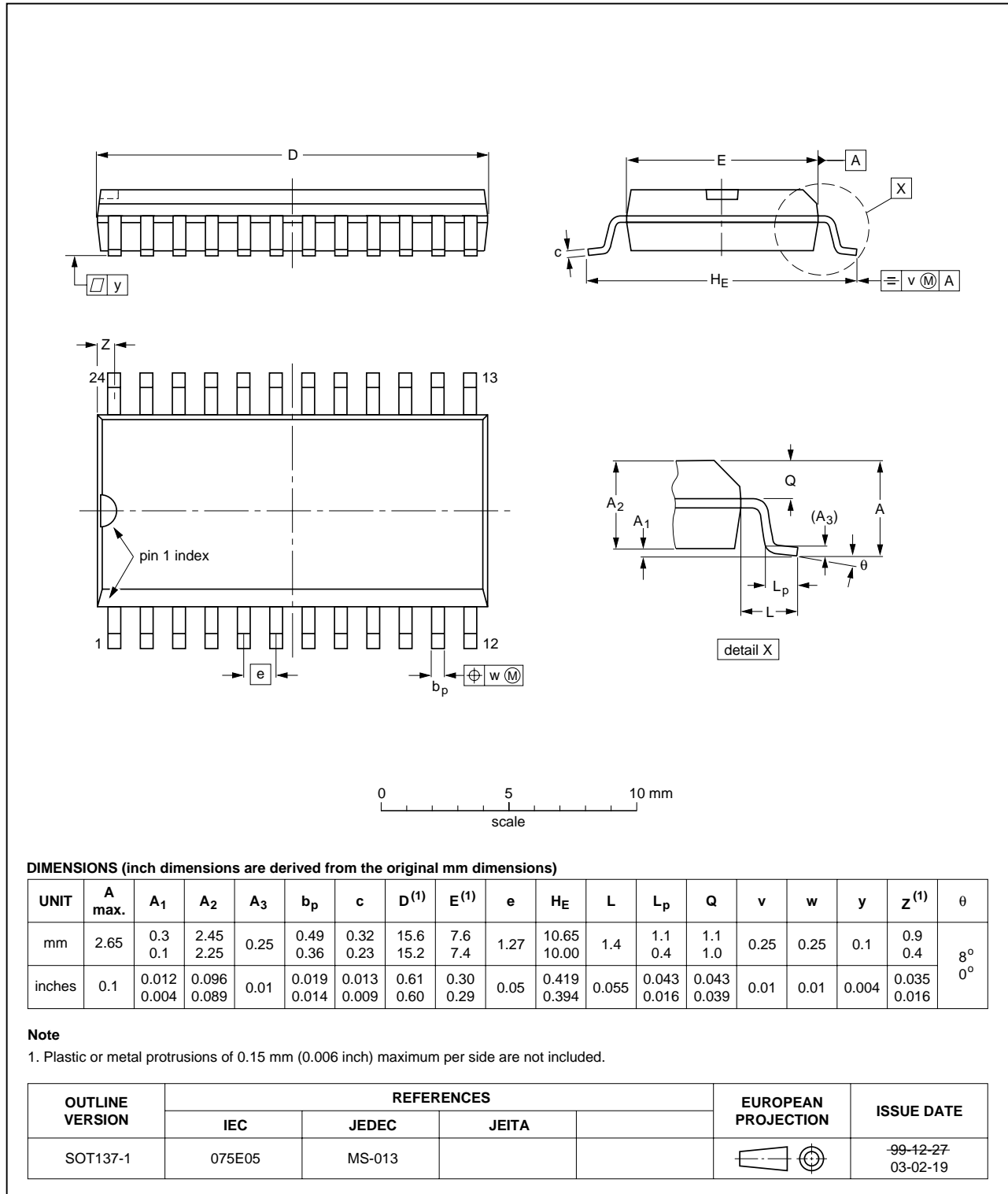

4-to-16 line decoder/demultiplexer

74HC154; 74HCT154

SSOP24: plastic shrink small outline package; 24 leads; body width 5.3 mm

SOT340-1

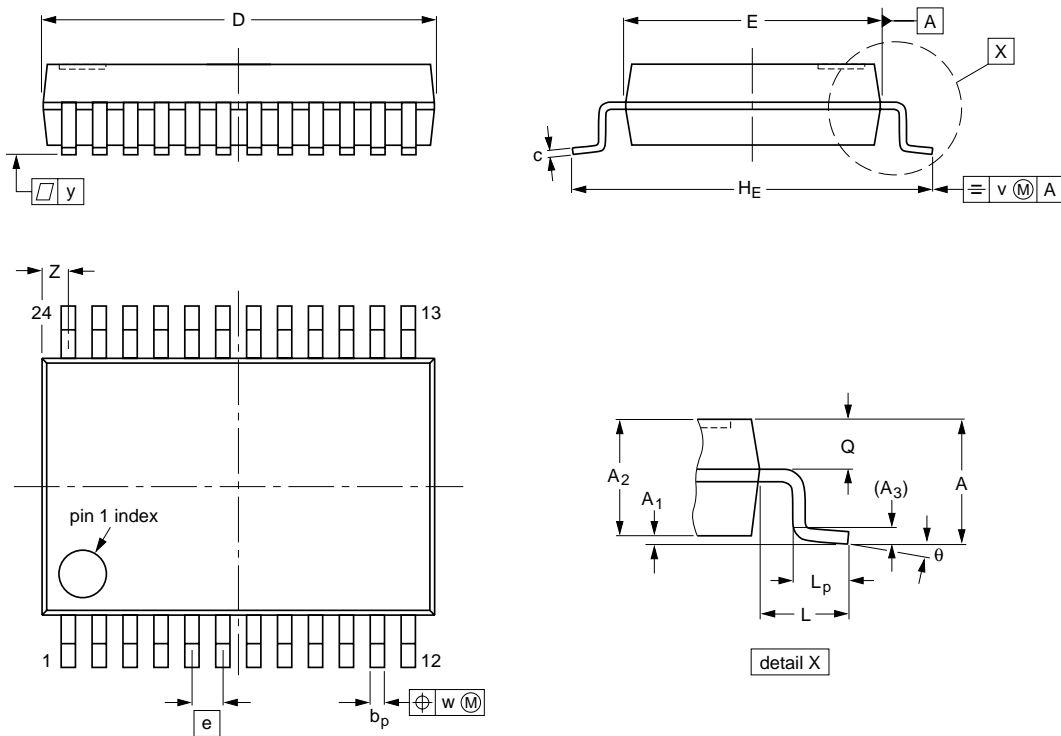

DIMENSIONS (mm are the original dimensions)

UNIT	A max.	A ₁	A ₂	A ₃	b _p	c	D ⁽¹⁾	E ⁽¹⁾	e	H _E	L	L _p	Q	v	w	y	z ⁽¹⁾	θ
mm	2	0.21 0.05	1.80 1.65	0.25	0.38 0.25	0.20 0.09	8.4 8.0	5.4 5.2	0.65	7.9 7.6	1.25	1.03 0.63	0.9 0.7	0.2	0.13	0.1	0.8 0.4	8° 0°

Note

1. Plastic or metal protrusions of 0.2 mm maximum per side are not included.

OUTLINE VERSION	REFERENCES				EUROPEAN PROJECTION	ISSUE DATE
	IEC	JEDEC	JEITA			
SOT340-1		MO-150				99-12-27 03-02-19

4-to-16 line decoder/demultiplexer

74HC154; 74HCT154

TSSOP24: plastic thin shrink small outline package; 24 leads; body width 4.4 mm

SOT355-1

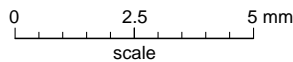
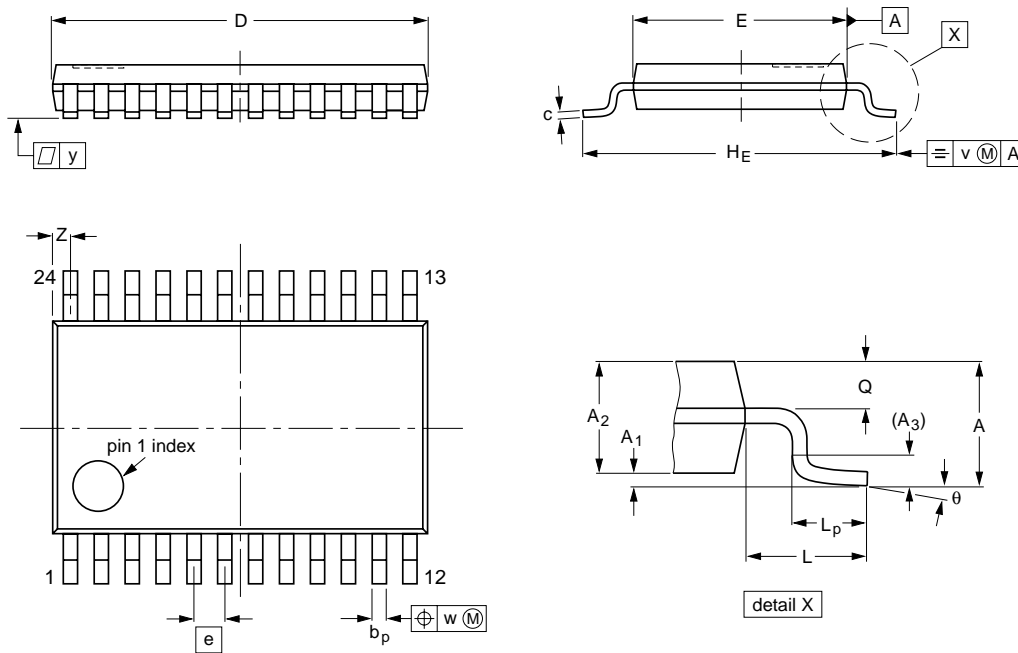

DIMENSIONS (mm are the original dimensions)

UNIT	A max.	A ₁	A ₂	A ₃	b _p	c	D ⁽¹⁾	E ⁽²⁾	e	H _E	L	L _p	Q	v	w	y	z ⁽¹⁾	θ
mm	1.1	0.15 0.05	0.95 0.80	0.25	0.30 0.19	0.2 0.1	7.9 7.7	4.5 4.3	0.65	6.6 6.2	1	0.75 0.50	0.4 0.3	0.2	0.13	0.1	0.5 0.2	8° 0°

Notes

1. Plastic or metal protrusions of 0.15 mm maximum per side are not included.
2. Plastic interlead protrusions of 0.25 mm maximum per side are not included.

OUTLINE VERSION	REFERENCES				EUROPEAN PROJECTION	ISSUE DATE
	IEC	JEDEC	JEITA			
SOT355-1		MO-153				99-12-27 03-02-19

4-to-16 line decoder/demultiplexer

74HC154; 74HCT154

DHVQFN24: plastic dual in-line compatible thermal enhanced very thin quad flat package;
no leads; 24 terminals; body 3.5 x 5.5 x 0.85 mm

SOT815-1

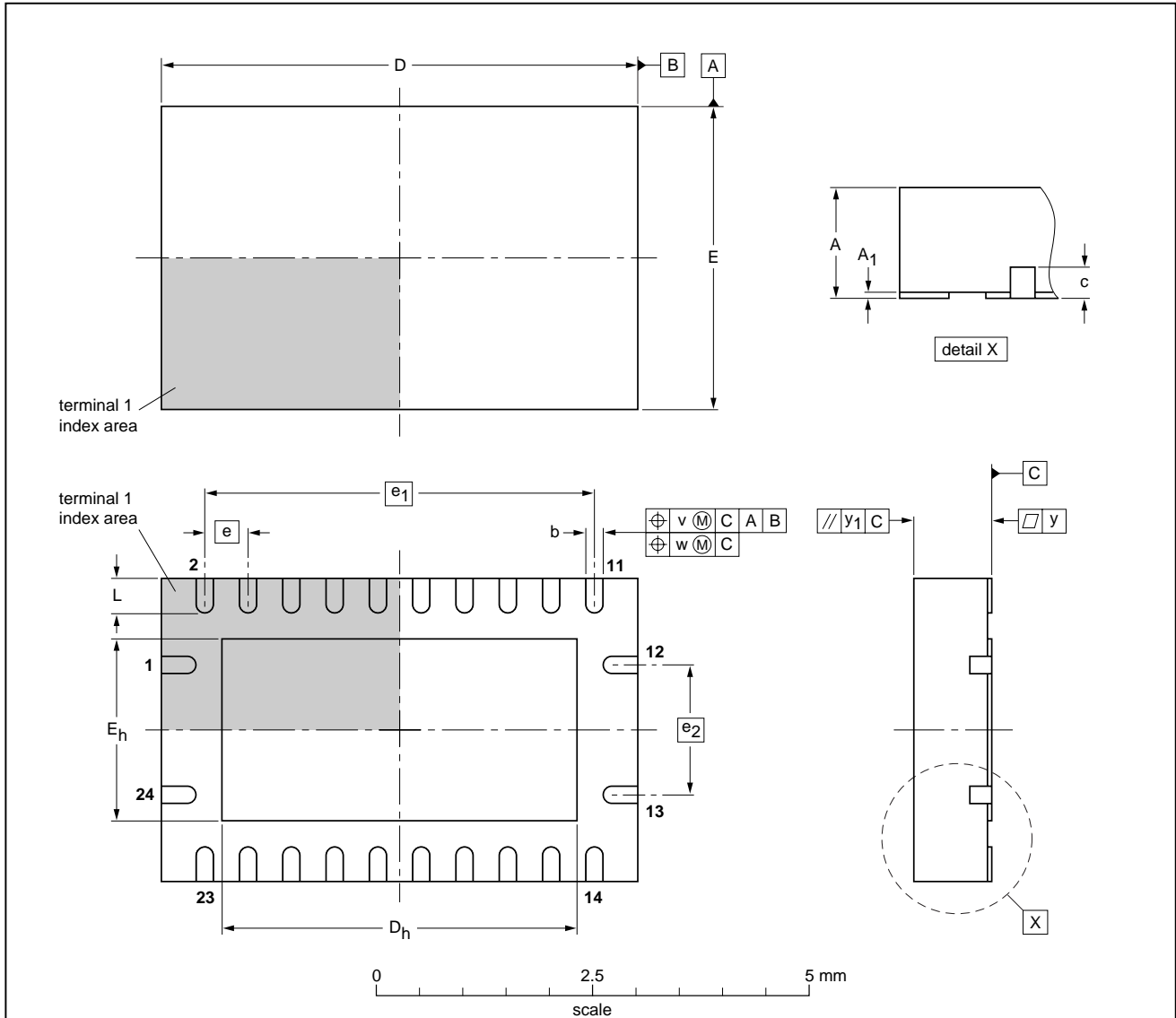

DIMENSIONS (mm are the original dimensions)

UNIT	A ⁽¹⁾ max.	A ₁	b	c	D ⁽¹⁾	D _h	E ⁽¹⁾	E _h	e	e ₁	e ₂	L	v	w	y	y ₁
mm	1	0.05 0.00	0.30 0.18	0.2	5.6 5.4	4.25 3.95	3.6 3.4	2.25 1.95	0.5	4.5	1.5	0.5 0.3	0.1	0.05	0.05	0.1

Note

1. Plastic or metal protrusions of 0.075 mm maximum per side are not included.

OUTLINE VERSION	REFERENCES				EUROPEAN PROJECTION	ISSUE DATE
	IEC	JEDEC	JEITA			
SOT815-1	---	---	---			03-04-29

4-to-16 line decoder/demultiplexer

74HC154; 74HCT154

DATA SHEET STATUS

LEVEL	DATA SHEET STATUS ⁽¹⁾	PRODUCT STATUS ⁽²⁾⁽³⁾	DEFINITION
I	Objective data	Development	This data sheet contains data from the objective specification for product development. Philips Semiconductors reserves the right to change the specification in any manner without notice.
II	Preliminary data	Qualification	This data sheet contains data from the preliminary specification. Supplementary data will be published at a later date. Philips Semiconductors reserves the right to change the specification without notice, in order to improve the design and supply the best possible product.
III	Product data	Production	This data sheet contains data from the product specification. Philips Semiconductors reserves the right to make changes at any time in order to improve the design, manufacturing and supply. Relevant changes will be communicated via a Customer Product/Process Change Notification (CPCN).

Notes

1. Please consult the most recently issued data sheet before initiating or completing a design.
2. The product status of the device(s) described in this data sheet may have changed since this data sheet was published. The latest information is available on the Internet at URL <http://www.semiconductors.philips.com>.
3. For data sheets describing multiple type numbers, the highest-level product status determines the data sheet status.

DEFINITIONS

Short-form specification — The data in a short-form specification is extracted from a full data sheet with the same type number and title. For detailed information see the relevant data sheet or data handbook.

Limiting values definition — Limiting values given are in accordance with the Absolute Maximum Rating System (IEC 60134). Stress above one or more of the limiting values may cause permanent damage to the device. These are stress ratings only and operation of the device at these or at any other conditions above those given in the Characteristics sections of the specification is not implied. Exposure to limiting values for extended periods may affect device reliability.

Application information — Applications that are described herein for any of these products are for illustrative purposes only. Philips Semiconductors make no representation or warranty that such applications will be suitable for the specified use without further testing or modification.

DISCLAIMERS

Life support applications — These products are not designed for use in life support appliances, devices, or systems where malfunction of these products can reasonably be expected to result in personal injury. Philips Semiconductors customers using or selling these products for use in such applications do so at their own risk and agree to fully indemnify Philips Semiconductors for any damages resulting from such application.

Right to make changes — Philips Semiconductors reserves the right to make changes in the products - including circuits, standard cells, and/or software - described or contained herein in order to improve design and/or performance. When the product is in full production (status 'Production'), relevant changes will be communicated via a Customer Product/Process Change Notification (CPCN). Philips Semiconductors assumes no responsibility or liability for the use of any of these products, conveys no licence or title under any patent, copyright, or mask work right to these products, and makes no representations or warranties that these products are free from patent, copyright, or mask work right infringement, unless otherwise specified.

Philips Semiconductors – a worldwide company

Contact information

For additional information please visit <http://www.semiconductors.philips.com>. Fax: +31 40 27 24825

For sales offices addresses send e-mail to: sales.addresses@www.semiconductors.philips.com.

© Koninklijke Philips Electronics N.V. 2004

SCA76

All rights are reserved. Reproduction in whole or in part is prohibited without the prior written consent of the copyright owner.

The information presented in this document does not form part of any quotation or contract, is believed to be accurate and reliable and may be changed without notice. No liability will be accepted by the publisher for any consequence of its use. Publication thereof does not convey nor imply any license under patent- or other industrial or intellectual property rights.

Printed in The Netherlands

R44/05/pp22

Date of release: 2004 Oct 12

Document order number: 9397 750 14191

Let's make things better.

**Philips
Semiconductors**



PHILIPS