

# DATA SHEET

## **74HC1G125; 74HCT1G125** **Bus buffer/line drivers; 3-state**

Product specification  
Supersedes data of 2002 May 17

2004 Jul 27

## Bus buffer/line drivers; 3-state

## 74HC1G125; 74HCT1G125

## FEATURES

- Wide supply voltage range from 2.0 to 6.0 V
- Symmetrical output impedance
- High noise immunity
- Low power dissipation
- Balanced propagation delays
- Very small 5 pins package
- Output capability: bus driver.

## DESCRIPTION

The 74HC1G/HCT1G125 is a high-speed Si-gate CMOS device.

The 74HC1G/HCT1G125 provides one non-inverting buffer/line driver with 3-state output. The 3-state output is controlled by the output enable input pin ( $\overline{OE}$ ). A HIGH at pin  $\overline{OE}$  causes the output as assume a high-impedance OFF-state.

The bus driver output currents are equal compared to the 74HC/HCT125.

## QUICK REFERENCE DATA

GND = 0 V;  $T_{amb} = 25\text{ }^{\circ}\text{C}$ ;  $t_r = t_f \leq 6.0\text{ ns}$ .

SYMBOL	PARAMETER	CONDITIONS	TYPICAL		UNIT
			HC1G	HCT1G	
$t_{PHL}/t_{PLH}$	propagation delay A to Y	$C_L = 15\text{ pF}$ ; $V_{CC} = 5\text{ V}$	9	10	ns
$C_I$	input capacitance		1.5	1.5	pF
$C_{PD}$	power dissipation capacitance	notes 1 and 2	30	27	pF

## Notes

1.  $C_{PD}$  is used to determine the dynamic power dissipation ( $P_D$  in  $\mu\text{W}$ ).

$$P_D = C_{PD} \times V_{CC}^2 \times f_i + \sum (C_L \times V_{CC}^2 \times f_o) \text{ where:}$$

$f_i$  = input frequency in MHz;

$f_o$  = output frequency in MHz;

$C_L$  = output load capacitance in pF;

$V_{CC}$  = supply voltage in Volts;

$\sum (C_L \times V_{CC}^2 \times f_o)$  = sum of outputs.

2. For HC1G the condition is  $V_I = \text{GND to } V_{CC}$ .

For HCT1G the condition is  $V_I = \text{GND to } V_{CC} - 1.5\text{ V}$ .

## FUNCTION TABLE

See note 1.

INPUTS		OUTPUT
$\overline{OE}$	A	Y
L	L	L
L	H	H
H	X	Z

## Note

1. H = HIGH voltage level;  
L = LOW voltage level;  
X = don't care;  
Z = high-impedance OFF-state.

Bus buffer/line drivers; 3-state

74HC1G125; 74HCT1G125

ORDERING INFORMATION

TYPE NUMBER	PACKAGE					
	TEMPERATURE RANGE	PINS	PACKAGE	MATERIAL	CODE	MARKING
74HC1G125GW	-40 to +125 °C	5	SC-88A	plastic	SOT353	HM
74HCT1G125GW	-40 to +125 °C	5	SC-88A	plastic	SOT353	TM
74HC1G125GV	-40 to +125 °C	5	SC-74A	plastic	SOT753	H25
74HCT1G125GV	-40 to +125 °C	5	SC-74A	plastic	SOT753	T25

PINNING

PIN	SYMBOL	DESCRIPTION
1	$\overline{OE}$	output enable input
2	A	data input A
3	GND	ground (0 V)
4	Y	data output Y
5	V <sub>CC</sub>	supply voltage

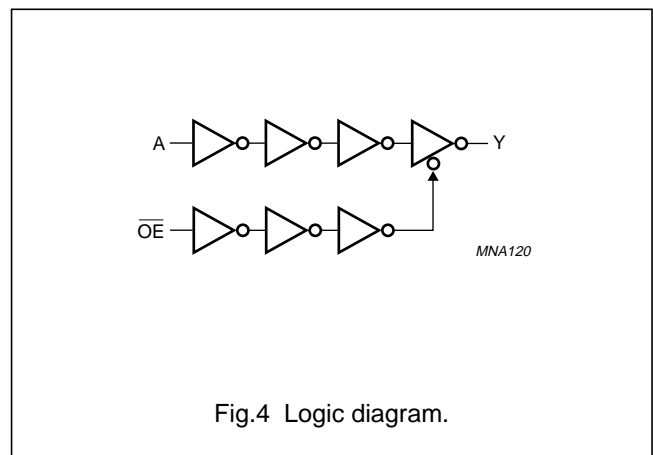
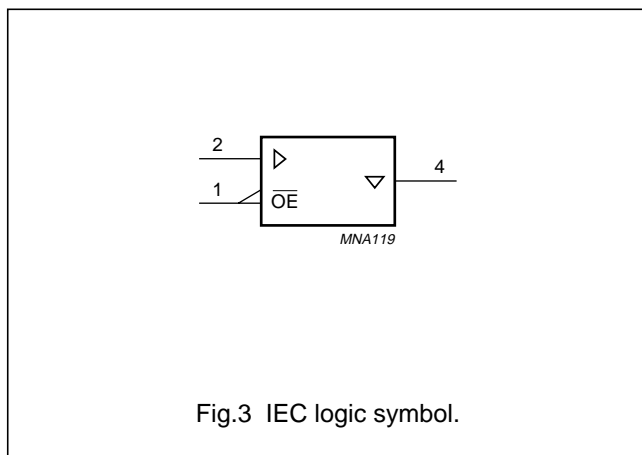
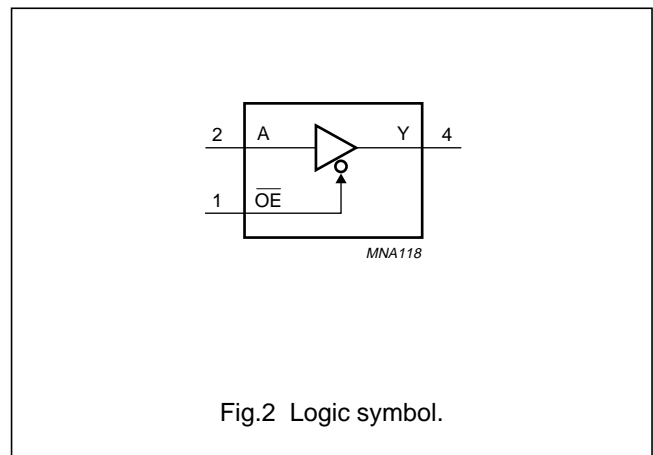
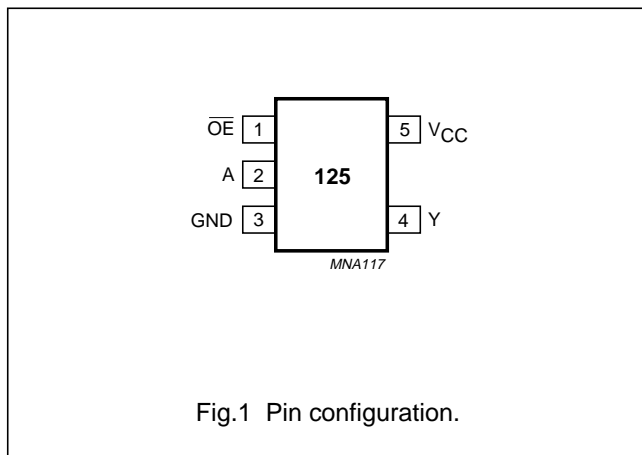

## Bus buffer/line drivers; 3-state

## 74HC1G125; 74HCT1G125

## RECOMMENDED OPERATING CONDITIONS

SYMBOL	PARAMETER	CONDITIONS	74HC1G125			74HCT1G125			UNIT
			MIN.	TYP.	MAX.	MIN.	TYP.	MAX.	
$V_{CC}$	supply voltage		2.0	5.0	6.0	4.5	5.0	5.5	V
$V_I$	input voltage		0	–	$V_{CC}$	0	–	$V_{CC}$	V
$V_O$	output voltage		0	–	$V_{CC}$	0	–	$V_{CC}$	V
$T_{amb}$	operating ambient temperature	see DC and AC characteristics per device	–40	+25	+125	–40	+25	+125	°C
$t_r, t_f$	input rise and fall times	$V_{CC} = 2.0$ V	–	–	1000	–	–	–	ns
		$V_{CC} = 4.5$ V	–	–	500	–	–	500	ns
		$V_{CC} = 6.0$ V	–	–	400	–	–	–	ns

## LIMITING VALUES

In accordance with the Absolute Maximum Rating System (IEC 60134); voltages are referenced to GND (ground = 0 V).

SYMBOL	PARAMETER	CONDITIONS	MIN.	MAX.	UNIT
$V_{CC}$	supply voltage		–0.5	+7.0	V
$I_{IK}$	input diode current	$V_I < -0.5$ V or $V_I > V_{CC} + 0.5$ V; note 1	–	±20	mA
$I_{OK}$	output diode current	$V_O < -0.5$ V or $V_O > V_{CC} + 0.5$ V; note 1	–	±20	mA
$I_O$	output source or sink current	$-0.5$ V < $V_O < V_{CC} + 0.5$ V; note 1	–	±12.5	mA
$I_{CC}$	$V_{CC}$ or GND current	note 1	–	±25	mA
$T_{stg}$	storage temperature		–65	+150	°C
$P_D$	power dissipation per package	for temperature range from –40 to +125 °C; note 2	–	200	mW

## Notes

1. The input and output voltage ratings may be exceeded if the input and output current ratings are observed.
2. Above 55 °C the value of  $P_D$  derates linearly with 2.5 mW/K.

## Bus buffer/line drivers; 3-state

## 74HC1G125; 74HCT1G125

## DC CHARACTERISTICS

## Family 74HC1G

At recommended operating conditions; voltages are referenced to GND (ground = 0 V).

SYMBOL	PARAMETER	TEST CONDITIONS		$T_{amb}$ (°C)					UNIT
		OTHER	$V_{CC}$ (V)	-40 to +85			-40 to +125		
				MIN.	TYP. <sup>(1)</sup>	MAX.	MIN.	MAX.	
$V_{IH}$	HIGH-level input voltage		2.0	1.5	1.2	–	1.5	–	V
			4.5	3.15	2.4	–	3.15	–	V
			6.0	4.2	3.2	–	4.2	–	V
$V_{IL}$	LOW-level input voltage		2.0	–	0.8	0.5	–	0.5	V
			4.5	–	2.1	1.35	–	1.35	V
			6.0	–	2.8	1.8	–	1.8	V
$V_{OH}$	HIGH-level output voltage	$V_I = V_{IH}$ or $V_{IL}$ ; $I_O = -20 \mu A$	2.0	1.9	2.0	–	1.9	–	V
		$V_I = V_{IH}$ or $V_{IL}$ ; $I_O = -20 \mu A$	4.5	4.4	4.5	–	4.4	–	V
		$V_I = V_{IH}$ or $V_{IL}$ ; $I_O = -20 \mu A$	6.0	5.9	6.0	–	5.9	–	V
		$V_I = V_{IH}$ or $V_{IL}$ ; $I_O = -2.0 \text{ mA}$	4.5	4.13	4.32	–	3.7	–	V
		$V_I = V_{IH}$ or $V_{IL}$ ; $I_O = -2.6 \text{ mA}$	6.0	5.63	5.81	–	5.2	–	V
$V_{OL}$	LOW-level output voltage	$V_I = V_{IH}$ or $V_{IL}$ ; $I_O = 20 \mu A$	2.0	–	0	0.1	–	0.1	V
		$V_I = V_{IH}$ or $V_{IL}$ ; $I_O = 20 \mu A$	4.5	–	0	0.1	–	0.1	V
		$V_I = V_{IH}$ or $V_{IL}$ ; $I_O = 20 \mu A$	6.0	–	0	0.1	–	0.1	V
		$V_I = V_{IH}$ or $V_{IL}$ ; $I_O = 2.0 \text{ mA}$	4.5	–	0.15	0.33	–	0.4	V
		$V_I = V_{IH}$ or $V_{IL}$ ; $I_O = 2.6 \text{ mA}$	6.0	–	0.16	0.33	–	0.4	V
$I_{LI}$	input leakage current	$V_I = V_{CC}$ or GND	6.0	–	–	1.0	–	1.0	$\mu A$
$I_{OZ}$	3-state output current OFF-state	$V_I = V_{IH}$ or $V_{IL}$ ; $V_O = V_{CC}$ or GND	6.0	–	–	5	–	10	$\mu A$
$I_{CC}$	quiescent supply current	$V_I = V_{CC}$ or GND; $I_O = 0$	6.0	–	–	10	–	20	$\mu A$

## Note

1. All typical values are measured at  $T_{amb} = 25 \text{ }^\circ\text{C}$ .

## Bus buffer/line drivers; 3-state

## 74HC1G125; 74HCT1G125

## Family 74HCT1G

At recommended operating conditions; voltages are referenced to GND (ground = 0 V).

SYMBOL	PARAMETER	TEST CONDITIONS		T <sub>amb</sub> (°C)					UNIT
		OTHER	V <sub>CC</sub> (V)	-40 to +85			-40 to +125		
				MIN.	TYP. <sup>(1)</sup>	MAX.	MIN.	MAX.	
V <sub>IH</sub>	HIGH-level input voltage		4.5 to 5.5	2.0	1.6	–	2.0	–	V
V <sub>IL</sub>	LOW-level input voltage		4.5 to 5.5	–	1.2	0.8	–	0.8	V
V <sub>OH</sub>	HIGH-level output voltage	V <sub>I</sub> = V <sub>IH</sub> or V <sub>IL</sub> ; I <sub>O</sub> = –20 µA	4.5	4.4	4.5	–	4.4	–	V
		V <sub>I</sub> = V <sub>IH</sub> or V <sub>IL</sub> ; I <sub>O</sub> = –2.0 mA	4.5	4.13	4.32	–	3.7	–	V
V <sub>OL</sub>	LOW-level output voltage	V <sub>I</sub> = V <sub>IH</sub> or V <sub>IL</sub> ; I <sub>O</sub> = 20 µA	4.5	–	0	0.1	–	0.1	V
		V <sub>I</sub> = V <sub>IH</sub> or V <sub>IL</sub> ; I <sub>O</sub> = 2.0 mA	4.5	–	0.15	0.33	–	0.4	V
I <sub>LI</sub>	input leakage current	V <sub>I</sub> = V <sub>CC</sub> or GND	5.5	–	–	1.0	–	1.0	µA
I <sub>OZ</sub>	3-state output current OFF-state	V <sub>I</sub> = V <sub>IH</sub> or V <sub>IL</sub> ; V <sub>O</sub> = V <sub>CC</sub> or GND	5.5	–	–	5	–	10	µA
I <sub>CC</sub>	quiescent supply current	V <sub>I</sub> = V <sub>CC</sub> or GND; I <sub>O</sub> = 0	5.5	–	–	10	–	20	µA
ΔI <sub>CC</sub>	additional supply current per input	V <sub>I</sub> = V <sub>CC</sub> – 2.1 V; I <sub>O</sub> = 0	4.5 to 5.5	–	–	500	–	850	µA

## Note

1. All typical values are measured at T<sub>amb</sub> = 25 °C.

## Bus buffer/line drivers; 3-state

## 74HC1G125; 74HCT1G125

## AC CHARACTERISTICS

## Type 74HC1G125

GND = 0 V;  $t_r = t_f \leq 6.0$  ns;  $C_L = 50$  pF.

SYMBOL	PARAMETER	TEST CONDITIONS		$T_{amb}$ (°C)					UNIT
		WAVEFORMS	$V_{CC}$ (V)	-40 to +85			-40 to +125		
				MIN.	TYP. <sup>(1)</sup>	MAX.	MIN.	MAX.	
$t_{PHL}/t_{PLH}$	propagation delay A to Y	see Figs 5 and 7	2.0	–	24	125	–	150	ns
			4.5	–	10	25	–	30	ns
			6.0	–	8	21	–	26	ns
$t_{PZH}/t_{PZL}$	3-state output enable time $\overline{OE}$ to Y	see Figs 6 and 7	2.0	–	19	155	–	190	ns
			4.5	–	9	31	–	38	ns
			6.0	–	7	26	–	32	ns
$t_{PHZ}/t_{PLZ}$	3-state output disable time $\overline{OE}$ to Y	see Figs 6 and 7	2.0	–	18	155	–	190	ns
			4.5	–	12	31	–	38	ns
			6.0	–	11	26	–	32	ns

## Note

1. All typical values are measured at  $T_{amb} = 25$  °C.

## Type 74HCT1G125

GND = 0 V;  $t_r = t_f \leq 6.0$  ns;  $C_L = 50$  pF.

SYMBOL	PARAMETER	TEST CONDITIONS		$T_{amb}$ (°C)					UNIT
		WAVEFORMS	$V_{CC}$ (V)	-40 to +85			-40 to +125		
				MIN.	TYP. <sup>(1)</sup>	MAX.	MIN.	MAX.	
$t_{PHL}/t_{PLH}$	propagation delay A to Y	see Figs 5 and 7	4.5	–	11	30	–	36	ns
$t_{PZH}/t_{PZL}$	3-state output enable time $\overline{OE}$ to Y	see Figs 6 and 7	4.5	–	10	35	–	42	ns
$t_{PHZ}/t_{PLZ}$	3-state output disable time $\overline{OE}$ to Y	see Figs 6 and 7	4.5	–	11	31	–	38	ns

## Note

1. All typical values are measured at  $T_{amb} = 25$  °C.

Bus buffer/line drivers; 3-state

74HC1G125; 74HCT1G125

AC WAVEFORMS

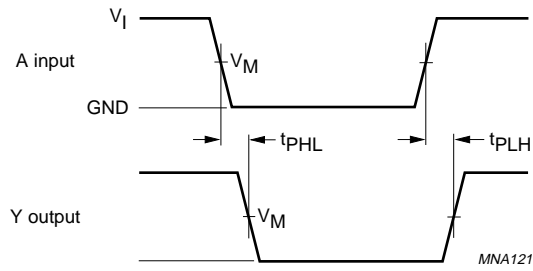

For HC1G:  $V_M = 50\%$ ;  $V_I = \text{GND to } V_{CC}$ .  
 For HCT1G:  $V_M = 1.3 \text{ V}$ ;  $V_I = \text{GND to } 3.0 \text{ V}$ .

Fig.5 The input (A) to output (Y) propagation delays.

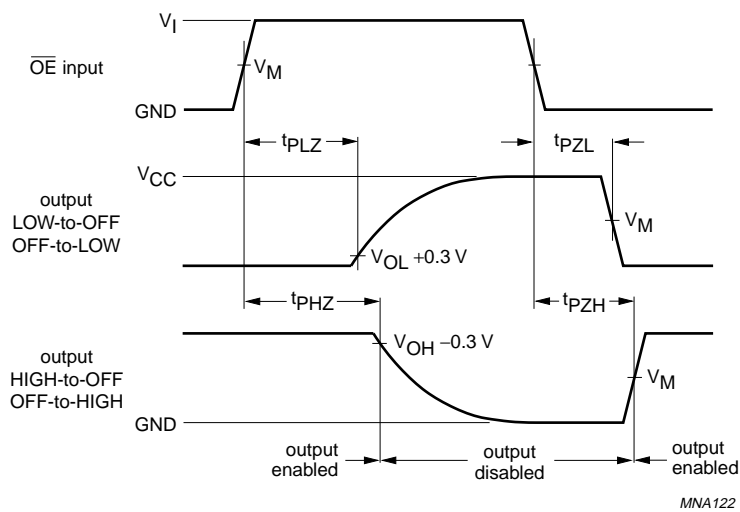

For HC1G:  $V_M = 50\%$ ;  $V_I = \text{GND to } V_{CC}$ .  
 For HCT1G:  $V_M = 1.3 \text{ V}$ ;  $V_I = \text{GND to } 3.0 \text{ V}$ .

Fig.6 The 3-state enable and disable times.

Bus buffer/line drivers; 3-state

74HC1G125; 74HCT1G125

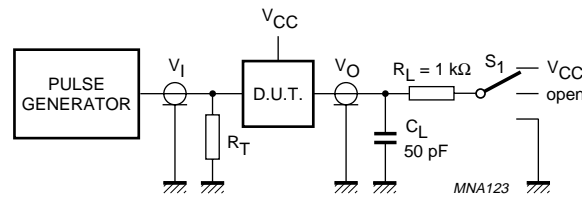

TEST	S <sub>1</sub>
t <sub>PLH</sub> /t <sub>PHL</sub>	open
t <sub>PLZ</sub> /t <sub>PZL</sub>	V <sub>CC</sub>
t <sub>PHZ</sub> /t <sub>PZH</sub>	GND

Definitions for test circuit:

C<sub>L</sub> = load capacitance including jig and probe capacitance (see "AC characteristics").

R<sub>T</sub> = termination resistance should be equal to the output impedance Z<sub>o</sub> of the pulse generator.

Fig.7 Load circuitry for switching times.

Bus buffer/line drivers; 3-state

74HC1G125; 74HCT1G125

PACKAGE OUTLINES

Plastic surface mounted package; 5 leads

SOT353

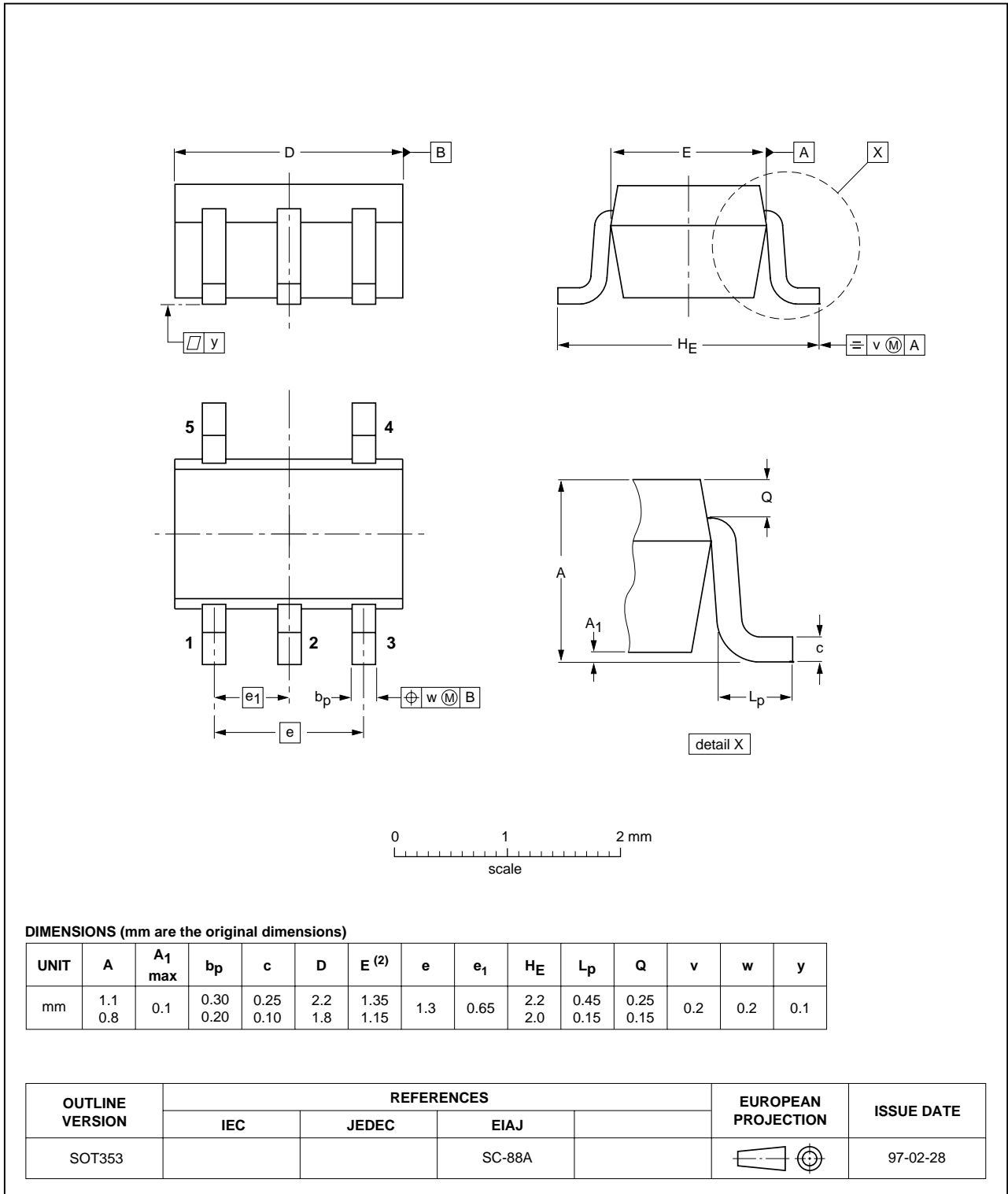

Bus buffer/line drivers; 3-state

74HC1G125; 74HCT1G125

Plastic surface mounted package; 5 leads

SOT753

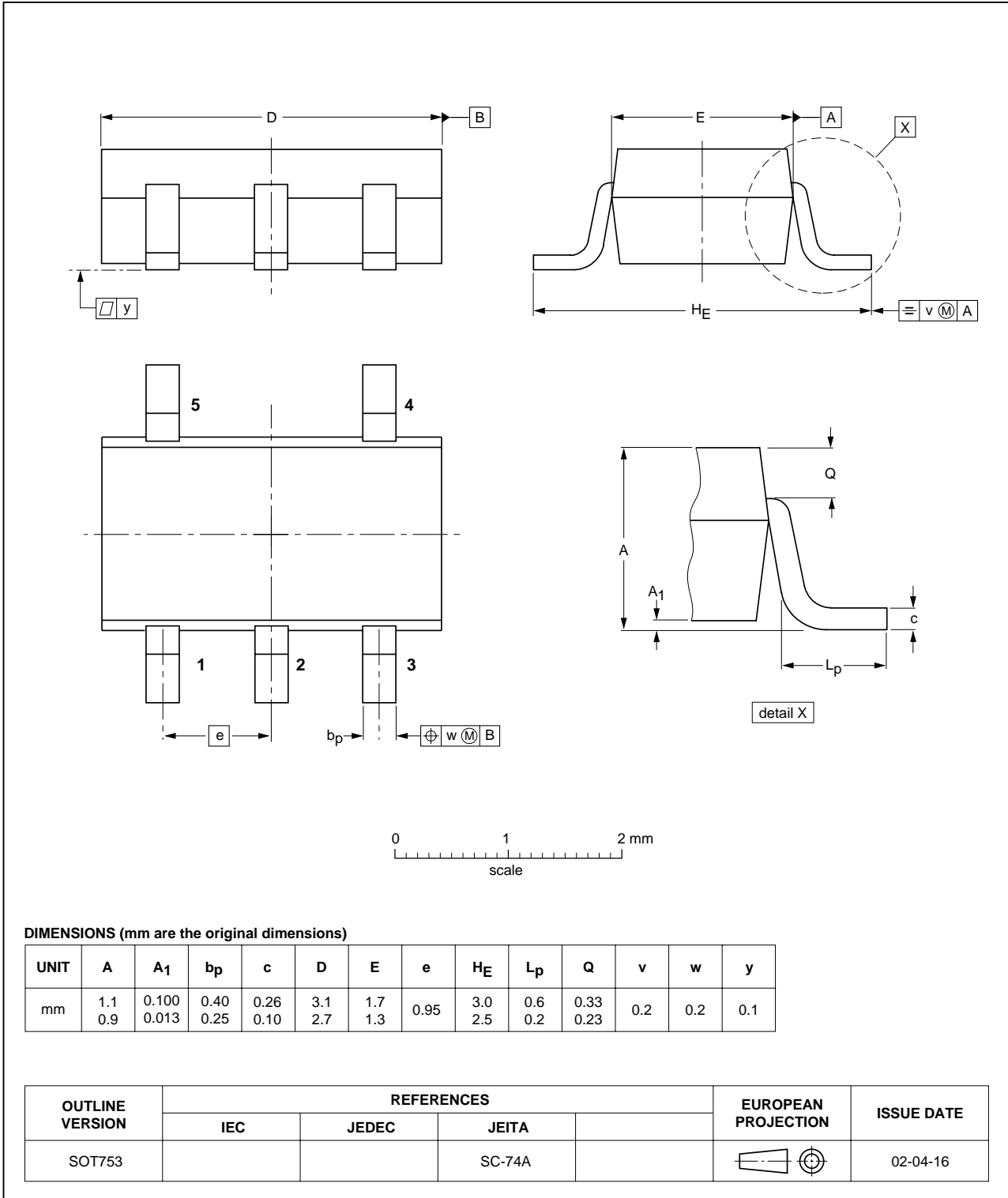

## Bus buffer/line drivers; 3-state

## 74HC1G125; 74HCT1G125

## DATA SHEET STATUS

LEVEL	DATA SHEET STATUS <sup>(1)</sup>	PRODUCT STATUS <sup>(2)(3)</sup>	DEFINITION
I	Objective data	Development	This data sheet contains data from the objective specification for product development. Philips Semiconductors reserves the right to change the specification in any manner without notice.
II	Preliminary data	Qualification	This data sheet contains data from the preliminary specification. Supplementary data will be published at a later date. Philips Semiconductors reserves the right to change the specification without notice, in order to improve the design and supply the best possible product.
III	Product data	Production	This data sheet contains data from the product specification. Philips Semiconductors reserves the right to make changes at any time in order to improve the design, manufacturing and supply. Relevant changes will be communicated via a Customer Product/Process Change Notification (CPCN).

## Notes

1. Please consult the most recently issued data sheet before initiating or completing a design.
2. The product status of the device(s) described in this data sheet may have changed since this data sheet was published. The latest information is available on the Internet at URL <http://www.semiconductors.philips.com>.
3. For data sheets describing multiple type numbers, the highest-level product status determines the data sheet status.

## DEFINITIONS

**Short-form specification** — The data in a short-form specification is extracted from a full data sheet with the same type number and title. For detailed information see the relevant data sheet or data handbook.

**Limiting values definition** — Limiting values given are in accordance with the Absolute Maximum Rating System (IEC 60134). Stress above one or more of the limiting values may cause permanent damage to the device. These are stress ratings only and operation of the device at these or at any other conditions above those given in the Characteristics sections of the specification is not implied. Exposure to limiting values for extended periods may affect device reliability.

**Application information** — Applications that are described herein for any of these products are for illustrative purposes only. Philips Semiconductors make no representation or warranty that such applications will be suitable for the specified use without further testing or modification.

## DISCLAIMERS

**Life support applications** — These products are not designed for use in life support appliances, devices, or systems where malfunction of these products can reasonably be expected to result in personal injury. Philips Semiconductors customers using or selling these products for use in such applications do so at their own risk and agree to fully indemnify Philips Semiconductors for any damages resulting from such application.

**Right to make changes** — Philips Semiconductors reserves the right to make changes in the products - including circuits, standard cells, and/or software - described or contained herein in order to improve design and/or performance. When the product is in full production (status 'Production'), relevant changes will be communicated via a Customer Product/Process Change Notification (CPCN). Philips Semiconductors assumes no responsibility or liability for the use of any of these products, conveys no licence or title under any patent, copyright, or mask work right to these products, and makes no representations or warranties that these products are free from patent, copyright, or mask work right infringement, unless otherwise specified.

# ***Philips Semiconductors – a worldwide company***

## **Contact information**

For additional information please visit <http://www.semiconductors.philips.com>. Fax: +31 40 27 24825

For sales offices addresses send e-mail to: [sales.addresses@www.semiconductors.philips.com](mailto:sales.addresses@www.semiconductors.philips.com).

© Koninklijke Philips Electronics N.V. 2004

SCA76

All rights are reserved. Reproduction in whole or in part is prohibited without the prior written consent of the copyright owner.

The information presented in this document does not form part of any quotation or contract, is believed to be accurate and reliable and may be changed without notice. No liability will be accepted by the publisher for any consequence of its use. Publication thereof does not convey nor imply any license under patent- or other industrial or intellectual property rights.

Printed in The Netherlands

R44/04/pp13

Date of release: 2004 Jul 27

Document order number: 9397 750 13725

*Let's make things better.*

**Philips  
Semiconductors**



**PHILIPS**