

DATA SHEET

74HC2G66; 74HCT2G66 Bilateral switches

Product specification
Supersedes data of 2003 Nov 26

2004 May 19

Bilateral switches

74HC2G66; 74HCT2G66

FEATURES

- Wide supply voltage range from 2.0 V to 9.0 V
- Very low ON-resistance:
 - 41 Ω (typical) at $V_{CC} = 4.5$ V
 - 30 Ω (typical) at $V_{CC} = 6.0$ V
 - 21 Ω (typical) at $V_{CC} = 9.0$ V.
- High noise immunity
- Low power dissipation
- ± 25 mA switch current
- SOT505-2 package
- ESD protection:
HBM EIA/JESD22-A114-A exceeds 2000 V
MM EIA/JESD22-A115-A exceeds 200 V.
- Specified from -40 °C to $+85$ °C and -40 °C to $+125$ °C.

DESCRIPTION

The 74HC2G66/74HCT2G66 is a high-speed Si-gate CMOS device.

The 74HC2G66/74HCT2G66 provides a dual analog switch. Each switch has two pins (nY and nZ) for input or output and an active HIGH enable input (pin E). When pin E is LOW, the belonging analog switch is turned off.

QUICK REFERENCE DATA

$GND = 0$ V; $T_{amb} = 25$ °C; $t_r = t_f = 6.0$ ns; V_{os} is the output voltage at pins nY or nZ, whichever is assigned as an output.

SYMBOL	PARAMETER	CONDITIONS	TYPICAL		UNIT
			HC2G	HCT2G	
t_{PZH}/t_{PZL}	turn-on time nE to V_{os}	$C_L = 50$ pF; $R_L = 1$ k Ω ; $V_{CC} = 4.5$ V	12	13	ns
t_{PHZ}/t_{PLZ}	turn-off time nE to V_{os}	$C_L = 50$ pF; $R_L = 1$ k Ω ; $V_{CC} = 4.5$ V	12	13	ns
C_I	input capacitance		3.5	3.5	pF
C_{PD}	power dissipation capacitance per switch	notes 1 and 2	9	9	pF
C_S	switch capacitance		8	8	pF

Notes

1. C_{PD} is used to determine the dynamic power dissipation (P_D in μ W).

$P_D = C_{PD} \times V_{CC}^2 \times f_i + (C_L + C_S) \times V_{CC}^2 \times f_o$ where:

f_i = input frequency in MHz;

f_o = output frequency in MHz;

C_L = output load capacitance in pF;

C_S = Switch capacitance in pF;

V_{CC} = supply voltage in Volts.

2. For 74HC2G66 the condition is $V_I = GND$ to V_{CC} .
For 74HCT2G66 the condition is $V_I = GND$ to $V_{CC} - 1.5$ V.

Bilateral switches

74HC2G66; 74HCT2G66

FUNCTION TABLE

See note 1.

INPUT nE	SWITCH
L	OFF
H	ON

Note

- 1. H = HIGH voltage level;
L = LOW voltage level.

ORDERING INFORMATION

TYPE NUMBER	PACKAGE					
	TEMPERATURE RANGE	PINS	PACKAGE	MATERIAL	OUTLINE VERSION	MARKING
74HC2G66DP	-40 °C to +125 °C	8	TSSOP8	plastic	SOT505-2	H66
74HCT2G66DP	-40 °C to +125 °C	8	TSSOP8	plastic	SOT505-2	T66

PINNING

PIN	SYMBOL	DESCRIPTION
1	1Y	independent input or output
2	1Z	independent input or output
3	2E	enable input (active HIGH)
4	GND	ground (0 V)
5	2Y	independent input or output
6	2Z	independent input or output
7	1E	enable input (active HIGH)
8	V _{CC}	supply voltage

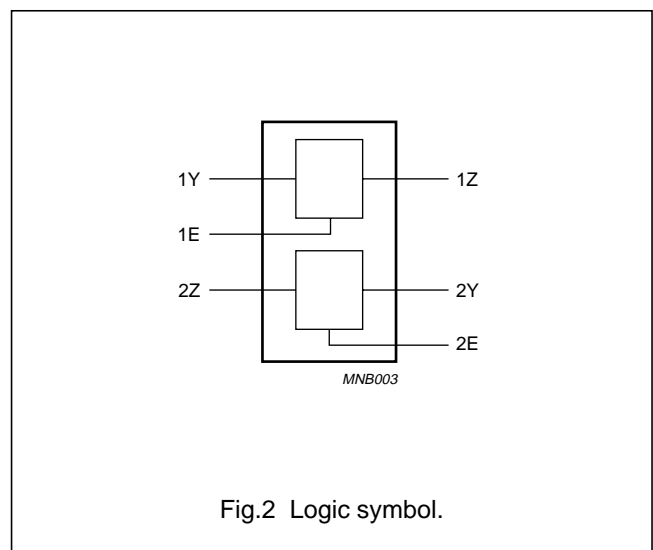
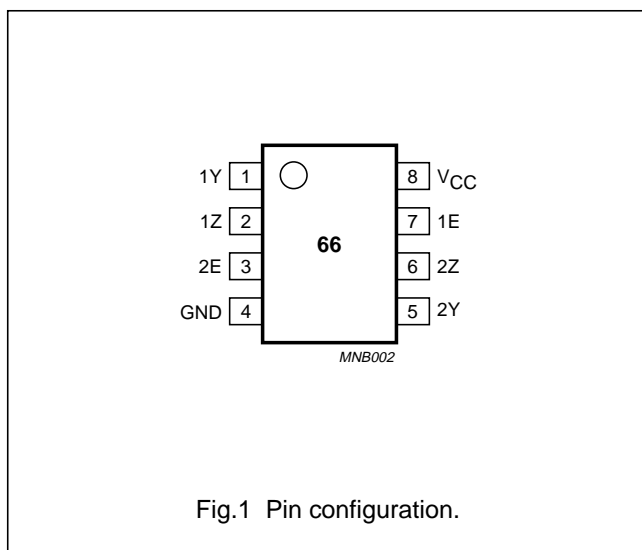

Bilateral switches

74HC2G66; 74HCT2G66

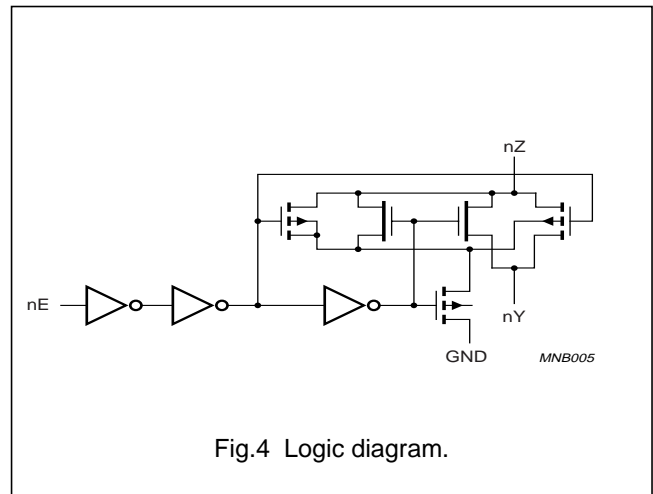
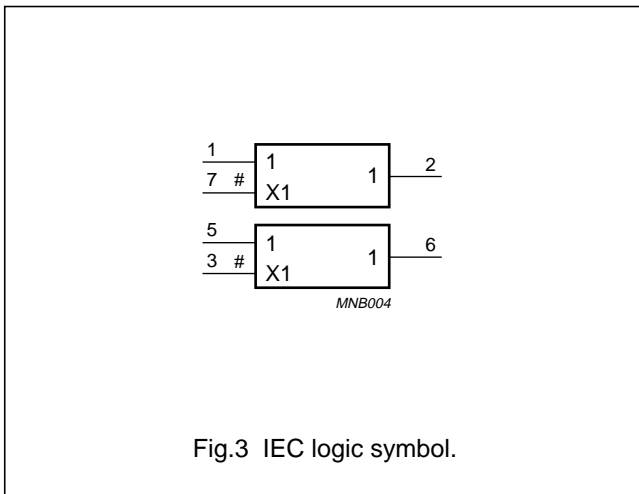

RECOMMENDED OPERATING CONDITIONS

SYMBOL	PARAMETER	CONDITIONS	74HC2G66			74HCT2G66			UNIT
			MIN.	TYP.	MAX.	MIN.	TYP.	MAX.	
V _{CC}	supply voltage		2.0	5.0	10.0	4.5	5.0	5.5	V
V _I	input voltage		0	–	V _{CC}	0	–	V _{CC}	V
V _O	output voltage		0	–	V _{CC}	0	–	V _{CC}	V
T _{amb}	ambient temperature	see DC and AC characteristics per device	–40	+25	+125	–40	+25	+125	°C
t _r , t _f	input rise and fall times	V _{CC} = 2.0 V	–	–	1000	–	–	–	ns
		V _{CC} = 4.5 V	–	6.0	500	–	6.0	500	ns
		V _{CC} = 6.0 V	–	–	400	–	–	–	ns
		V _{CC} = 9.0 V	–	–	250	–	–	–	ns

LIMITING VALUES

In accordance with the Absolute Maximum Rating System (IEC 60134); voltages are referenced to GND (ground = 0 V).

SYMBOL	PARAMETER	CONDITIONS	MIN.	MAX.	UNIT
V _{CC}	supply voltage		–0.5	+11.0	V
I _{IK}	input diode current	V _I < –0.5 V or V _I > V _{CC} + 0.5 V; note 1	–	±20	mA
I _{OK}	output diode current	V _O < –0.5 V or V _O > V _{CC} + 0.5 V; note 1	–	±20	mA
I _O	output source or sink current	–0.5 V < V _O < V _{CC} + 0.5 V; note 1	–	±25	mA
I _{CC} , I _{GND}	V _{CC} or GND current	note 1	–	±30	mA
T _{stg}	storage temperature		–65	+150	°C
P _{tot}	power dissipation of package	T _{amb} = –40 °C to +125 °C; note 2	–	300	mW
P _s	power dissipation per switch		–	100	mW

Notes

1. The input and output voltage ratings may be exceeded if the input and output current ratings are observed.
2. Above 55 °C the value of P_{tot} derates linearly with 2.5 mW/K.

Bilateral switches

74HC2G66; 74HCT2G66

DC CHARACTERISTICS

Type 74HC2G66

At recommended operating conditions; voltages are referenced to GND (ground = 0 V).

SYMBOL	PARAMETER	TEST CONDITIONS		MIN.	TYP.	MAX.	UNIT
		OTHER	V _{CC} (V)				
T_{amb} = -40 °C to +85 °C; note1							
V _{IH}	HIGH-level input voltage		2.0	1.5	1.2	–	V
			4.5	3.15	2.4	–	V
			6.0	4.2	3.2	–	V
			9.0	6.3	4.7	–	V
V _{IL}	LOW-level input voltage		2.0	–	0.8	0.5	V
			4.5	–	2.1	1.35	V
			6.0	–	2.8	1.8	V
			9.0	–	4.3	2.7	V
I _{LI}	input leakage current	V _I = V _{CC} or GND	6.0	–	–	±0.1	µA
			9.0	–	–	±0.2	µA
I _{s(OFF)}	analog switch current, OFF-state	V _I = V _{IH} or V _{IL} ; V _S = V _{CC} – GND; see Fig.7	9.0	–	0.1	1.0	µA
I _{s(ON)}	analog switch current, ON-state	V _I = V _{IH} or V _{IL} ; V _S = V _{CC} – GND; see Fig.8	9.0	–	0.1	1.0	µA
I _{CC}	quiescent supply current	V _I = V _{CC} or GND; V _{is} = GND or V _{CC} ; V _{os} = V _{CC} or GND	6.0	–	–	10	µA
			9.0	–	–	20	µA

Bilateral switches

74HC2G66; 74HCT2G66

SYMBOL	PARAMETER	TEST CONDITIONS		MIN.	TYP.	MAX.	UNIT
		OTHER	V _{CC} (V)				
T_{amb} = -40 °C to +125 °C							
V _{IH}	HIGH-level input voltage		2.0	1.5	–	–	V
			4.5	3.15	–	–	V
			6.0	4.2	–	–	V
			9.0	6.3	–	–	V
V _{IL}	LOW-level input voltage		2.0	–	–	0.5	V
			4.5	–	–	1.35	V
			6.0	–	–	1.8	V
			9.0	–	–	2.7	V
I _{LI}	input leakage current	V _I = V _{CC} or GND	6.0	–	–	±0.1	µA
			9.0	–	–	±0.2	µA
I _{s(OFF)}	analog switch current, OFF-state	V _I = V _{IH} or V _{IL} ; V _S = V _{CC} – GND; see Fig.7	9.0	–	–	1.0	µA
I _{s(ON)}	analog switch current, ON-state	V _I = V _{IH} or V _{IL} ; V _S = V _{CC} – GND; see Fig.8	9.0	–	–	1.0	µA
I _{CC}	quiescent supply current	V _I = V _{CC} or GND; V _{IS} = GND or V _{CC} ; V _{OS} = V _{CC} or GND	6.0	–	–	20	µA
			9.0	–	–	40	µA

Note

1. All typical values are measured at T_{amb} = 25 °C.

Bilateral switches

74HC2G66; 74HCT2G66

Type 74HCT2G66

At recommended operating conditions; voltages are referenced to GND (ground = 0 V).

SYMBOL	PARAMETER	TEST CONDITIONS		MIN.	TYP.	MAX.	UNIT
		OTHER	V _{CC} (V)				
T_{amb} = -40 °C to +85 °C; note 1							
V _{IH}	HIGH-level input voltage		4.5 to 5.5	2.0	1.6	–	V
V _{IL}	LOW-level input voltage		4.5 to 5.5	–	1.2	0.8	V
I _{LI}	input leakage current	V _I = V _{CC} or GND	5.5	–	–	±1.0	µA
I _{s(OFF)}	analog switch current, OFF-state	V _I = V _{IH} or V _{IL} ; V _S = V _{CC} – GND; see Fig.7		–	0.1	1.0	µA
I _{s(ON)}	analog switch current, ON-state	V _I = V _{IH} or V _{IL} ; V _S = V _{CC} – GND; see Fig.8		–	0.1	1.0	µA
I _{CC}	quiescent supply current	V _I = V _{CC} or GND; V _{IS} = GND or V _{CC} ; V _{OS} = V _{CC} or GND	4.5 to 5.5	–	–	10	µA
ΔI _{CC}	additional supply current per input	V _I = V _{CC} – 2.1 V; I _O = 0 A	4.5 to 5.5	–	–	375	µA
T_{amb} = -40 °C to +125 °C							
V _{IH}	HIGH-level input voltage		4.5 to 5.5	2.0	–	–	V
V _{IL}	LOW-level input voltage		4.5 to 5.5	–	–	0.8	V
I _{LI}	input leakage current	V _I = V _{CC} or GND	5.5	–	–	±1.0	µA
I _{s(OFF)}	analog switch current, OFF-state	V _I = V _{IH} or V _{IL} ; V _S = V _{CC} – GND; see Fig.7		–	–	1.0	µA
I _{s(ON)}	analog switch current, ON-state	V _I = V _{IH} or V _{IL} ; V _S = V _{CC} – GND; see Fig.8		–	–	1.0	µA
I _{CC}	quiescent supply current	V _I = V _{CC} or GND; V _{IS} = GND or V _{CC} ; V _{OS} = V _{CC} or GND	4.5 to 5.5	–	–	20	µA
ΔI _{CC}	additional supply current per input	V _I = V _{CC} – 2.1 V; I _O = 0 A	4.5 to 5.5	–	–	410	µA

Note1. All typical values are measured at T_{amb} = 25 °C.

Bilateral switches

74HC2G66; 74HCT2G66

Resistance R_{ON} for 74HC2G66 and 74HCT2G66

See notes 1 and 2.

SYMBOL	PARAMETER	TEST CONDITIONS			MIN.	TYP.	MAX.	UNIT
		OTHER	V_{CC} (V)	I_s (μ A)				
$T_{amb} = -40\text{ }^{\circ}\text{C}$ to $+85\text{ }^{\circ}\text{C}$; note 3								
$R_{ON(peak)}$	ON-resistance (peak)	$V_{is} = V_{CC}$ to GND; $V_I = V_{IH}$ or V_{IL} ; see Figs 5 and 6	2.0	100	–	250	–	Ω
			4.5	1000	–	41	118	Ω
			6.0	1000	–	30	105	Ω
			9.0	1000	–	21	88	Ω
$R_{ON(rail)}$	ON-resistance (rail)	$V_{is} = \text{GND}$; $V_I = V_{IH}$ or V_{IL} ; see Figs 5 and 6	2.0	100	–	65	–	Ω
			4.5	1000	–	28	95	Ω
			6.0	1000	–	22	82	Ω
			9.0	1000	–	18	70	Ω
	$V_{is} = V_{CC}$; $V_I = V_{IH}$ or V_{IL} ; see Figs 5 and 6	2.0	100	–	65	–	Ω	
		4.5	1000	–	31	106	Ω	
		6.0	1000	–	23	94	Ω	
		9.0	1000	–	19	78	Ω	
ΔR_{ON}	maximum variation of ON-resistance between the two channels	$V_{is} = V_{CC}$ to GND; $V_I = V_{IH}$ or V_{IL} ; see Figs 5 and 6	4.5	–	–	5	–	Ω
			6.0	–	–	4	–	Ω
			9.0	–	–	3	–	Ω
$T_{amb} = -40\text{ }^{\circ}\text{C}$ to $+125\text{ }^{\circ}\text{C}$								
$R_{ON(peak)}$	ON-resistance (peak)	$V_{is} = V_{CC}$ to GND; $V_I = V_{IH}$ or V_{IL} ; see Figs 5 and 6	2.0	100	–	–	–	Ω
			4.5	1000	–	–	142	Ω
			6.0	1000	–	–	126	Ω
			9.0	1000	–	–	105	Ω
$R_{ON(rail)}$	ON-resistance (rail)	$V_{is} = \text{GND}$; $V_I = V_{IH}$ or V_{IL} ; see Figs 5 and 6	2.0	100	–	–	–	Ω
			4.5	1000	–	–	115	Ω
			6.0	1000	–	–	100	Ω
			9.0	1000	–	–	80	Ω
	$V_{is} = V_{CC}$; $V_I = V_{IH}$ or V_{IL} ; see Figs 5 and 6	2.0	100	–	–	–	Ω	
		4.5	1000	–	–	128	Ω	
		6.0	1000	–	–	113	Ω	
		9.0	1000	–	–	95	Ω	

Notes

- For 74 HCT2G66 only $V_{CC} = 4.5\text{ V}$ applies; for 74HC2G66 all V_{CC} values apply.
- At supply voltages near 2 V, the analog switch ON-resistance is extremely non linear. When using a supply of 2 V, it is recommended is to use these devices only for digital signals.
- All typical values are measured at $T_{amb} = 25\text{ }^{\circ}\text{C}$.

Bilateral switches

74HC2G66; 74HCT2G66

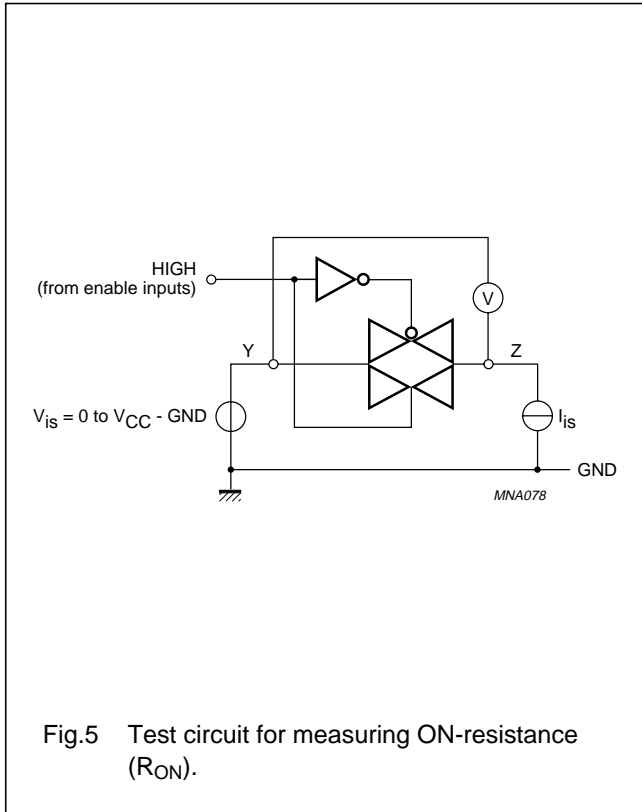
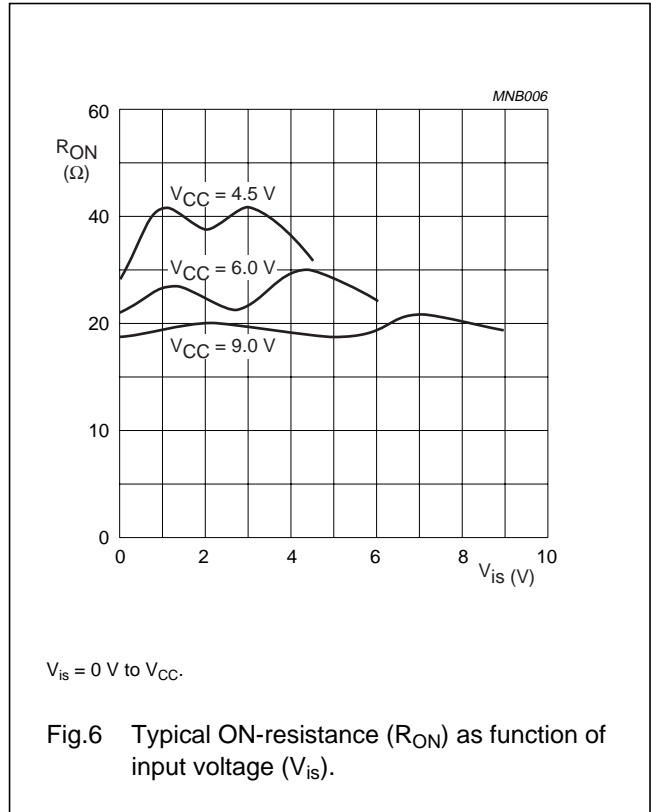

Fig.5 Test circuit for measuring ON-resistance (R_{ON}).



$V_{is} = 0 \text{ V to } V_{CC}$.

Fig.6 Typical ON-resistance (R_{ON}) as function of input voltage (V_{is}).

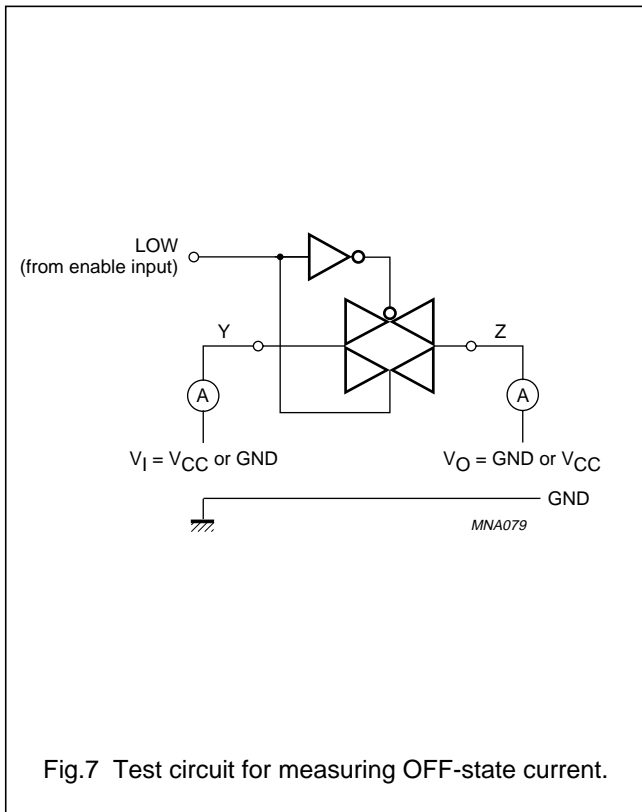

Fig.7 Test circuit for measuring OFF-state current.

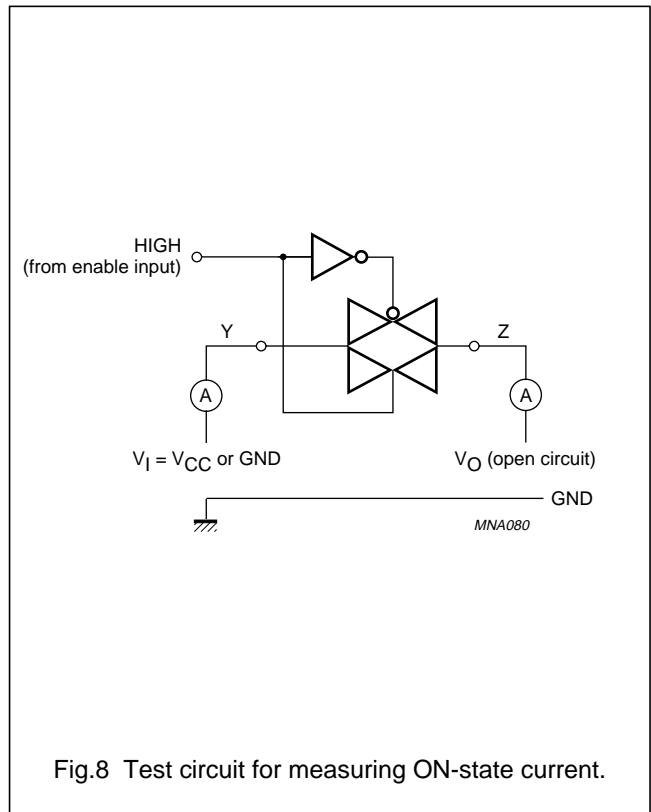

Fig.8 Test circuit for measuring ON-state current.

Bilateral switches

74HC2G66; 74HCT2G66

AC CHARACTERISTICS

Type 74HC2G66

GND = 0 V; $t_r = t_f = 6.0$ ns; V_{is} is the input voltage at pins nY or nZ, whichever is assigned as an input; V_{os} is the output voltage at pins nY or nZ, whichever is assigned as an output.

SYMBOL	PARAMETER	TEST CONDITIONS		MIN.	TYP.	MAX.	UNIT
		WAVEFORMS	V_{CC} (V)				
$T_{amb} = -40$ °C to $+85$ °C; note 1							
t_{PHL}/t_{PLH}	propagation delay V_{is} to V_{os}	$R_L = \infty$; see Figs 16 and 18	2.0	–	6.5	65	ns
			4.5	–	2.0	13	ns
			6.0	–	1.5	11	ns
			9.0	–	1.2	10	ns
t_{PZH}/t_{PZL}	turn-on time nE to V_{os}	$R_L = 1$ k Ω ; see Figs 17 and 18	2.0	–	40	125	ns
			4.5	–	12	25	ns
			6.0	–	10	21	ns
			9.0	–	7	16	ns
t_{PHZ}/t_{PLZ}	turn-off time nE to V_{os}	$R_L = 1$ k Ω ; see Figs 17 and 18	2.0	–	21	145	ns
			4.5	–	12	29	ns
			6.0	–	11	28	ns
			9.0	–	10	23	ns
$T_{amb} = -40$ °C to $+125$ °C							
t_{PHL}/t_{PLH}	propagation delay V_{is} to V_{os}	$R_L = \infty$; see Figs 16 and 18	2.0	–	–	80	ns
			4.5	–	–	15	ns
			6.0	–	–	14	ns
			9.0	–	–	12	ns
t_{PZH}/t_{PZL}	turn-on time nE to V_{os}	$R_L = 1$ k Ω ; see Figs 17 and 18	2.0	–	–	150	ns
			4.5	–	–	30	ns
			6.0	–	–	26	ns
			9.0	–	–	20	ns
t_{PHZ}/t_{PLZ}	turn-off time nE to V_{os}	$R_L = 1$ k Ω ; see Figs 17 and 18	2.0	–	–	175	ns
			4.5	–	–	35	ns
			6.0	–	–	33	ns
			9.0	–	–	27	ns

Note

1. All typical values are measured at $T_{amb} = 25$ °C.

Bilateral switches

74HC2G66; 74HCT2G66

Type 74HCT2G66

GND = 0 V; $t_r = t_f = 6.0$ ns; V_{is} is the input voltage at pins nY or nZ, whichever is assigned as an input; V_{os} is the output voltage at pins nY or nZ, whichever is assigned as an output.

SYMBOL	PARAMETER	TEST CONDITIONS		MIN.	TYP.	MAX.	UNIT
		WAVEFORMS	V_{CC} (V)				
$T_{amb} = -40$ °C to $+85$ °C; note 1							
t_{PHL}/t_{PLH}	propagation delay V_{is} to V_{os}	$R_L = \infty$; see Figs 16 and 18	4.5	–	2.0	15	ns
t_{PZH}/t_{PZL}	turn-on time nE to V_{os}	$R_L = 1$ k Ω ; see Figs 17 and 18	4.5	–	13	30	ns
t_{PHZ}/t_{PLZ}	turn-off time nE to V_{os}	$R_L = 1$ k Ω ; see Figs 17 and 18	4.5	–	13	44	ns
$T_{amb} = -40$ °C to $+125$ °C							
t_{PHL}/t_{PLH}	propagation delay V_{is} to V_{os}	$R_L = \infty$; see Figs 16 and 18	4.5	–	–	18	ns
t_{PZH}/t_{PZL}	turn-on time nE to V_{os}	$R_L = 1$ k Ω ; see Figs 17 and 18	4.5	–	–	36	ns
t_{PHZ}/t_{PLZ}	turn-off time nE to V_{os}	$R_L = 1$ k Ω ; see Figs 17 and 18	4.5	–	–	53	ns

Note

1. All typical values are measured at $T_{amb} = 25$ °C.

Bilateral switches

74HC2G66; 74HCT2G66

Type 74HC2G66 and 74HCT2G66

At recommended conditions and typical values; GND = 0 V; $t_r = t_f = 6.0$ ns; V_{is} is the input voltage at pins nY or nZ, whichever is assigned as an input; V_{os} is the output voltage at pins nY or nZ, whichever is assigned as an output.

SYMBOL	PARAMETER	TEST CONDITIONS			TYP.	UNIT
		OTHER	$V_{is(p-p)}$ (V)	V_{CC} (V)		
d_{sin}	sine-wave distortion	$f = 1$ kHz; $R_L = 10$ k Ω ; $C_L = 50$ pF; see Fig.14	4.0	4.5	0.04	%
			8.0	9.0	0.02	%
		$f = 10$ kHz; $R_L = 10$ k Ω ; $C_L = 50$ pF; see Fig.14	4.0	4.5	0.12	%
			8.0	9.0	0.06	%
$\alpha_{OFF(feedthru)}$	switch OFF signal feed-through	$R_L = 600$ Ω ; $C_L = 50$ pF; $f = 1$ MHz; see Figs 9 and 15	note 1	4.5	-50	dB
				9.0	-50	dB
$\alpha_{ct(s)}$	crosstalk between the two switches	$R_L = 600$ Ω ; $C_L = 50$ pF; $f = 1$ MHz; see Fig 11	note 1	4.5	-60	dB
				9.0	-60	dB
$V_{ct(E-S)(p-p)}$	crosstalk voltage between enable input to the switches (peak-to-peak value)	$R_L = 600$ Ω ; $C_L = 50$ pF; $f = 1$ MHz (nE, square wave between V_{CC} and GND, $t_r = t_f = 6.0$ ns); see Fig 12	note 1	4.5	110	mV
				9.0	220	mV
f_{max}	frequency response (-3 dB)	$R_L = 50$ Ω ; $C_L = 10$ pF; see Figs 10 and 13	note 2	4.5	180	MHz
				9.0	200	MHz
C_S	switch capacitance				8	pF

Notes

1. Adjust input voltage V_{is} is 0 dBm level (0 dBm = 1 mW into 600 Ω).
2. Adjust input voltage V_{is} is 0 dBm level at V_{os} for 1 MHz (0 dBm = 1 mW into 50 Ω).

Bilateral switches

74HC2G66; 74HCT2G66

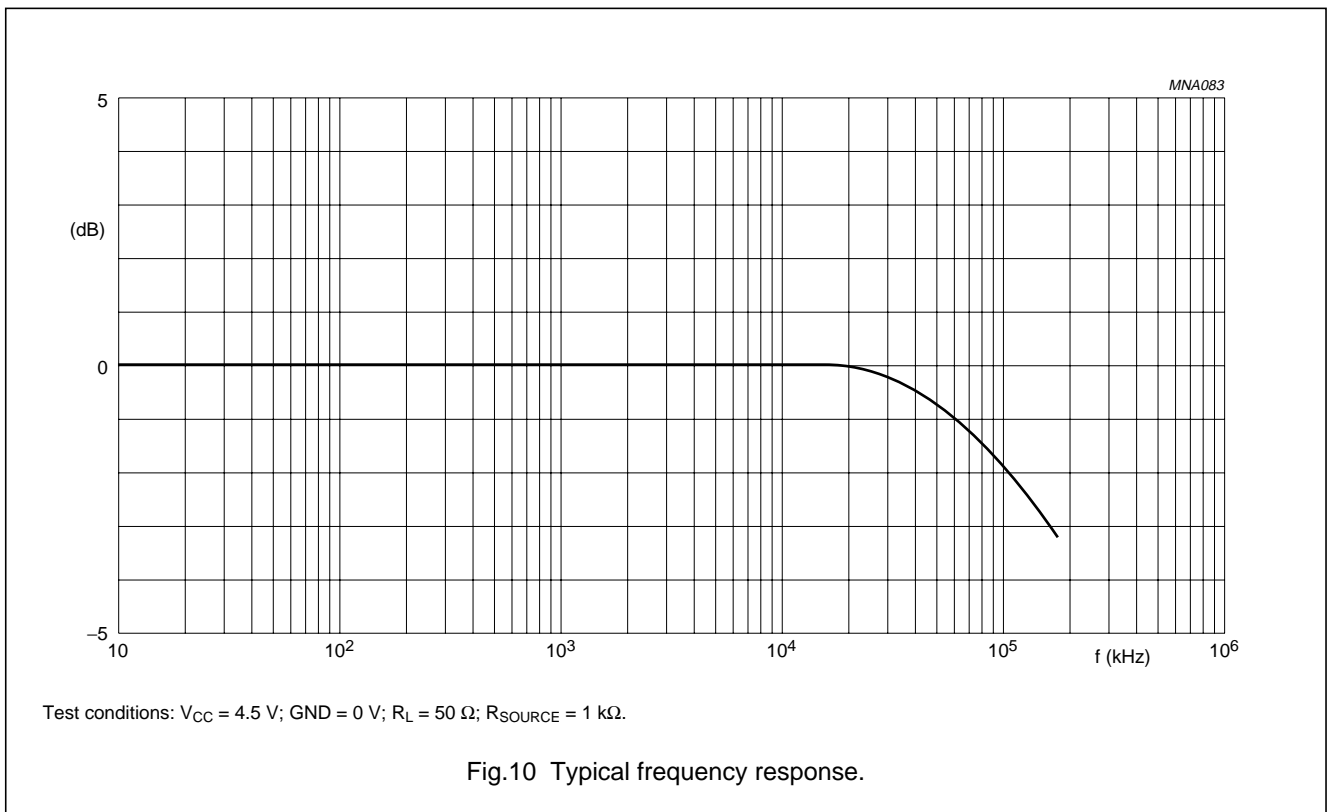
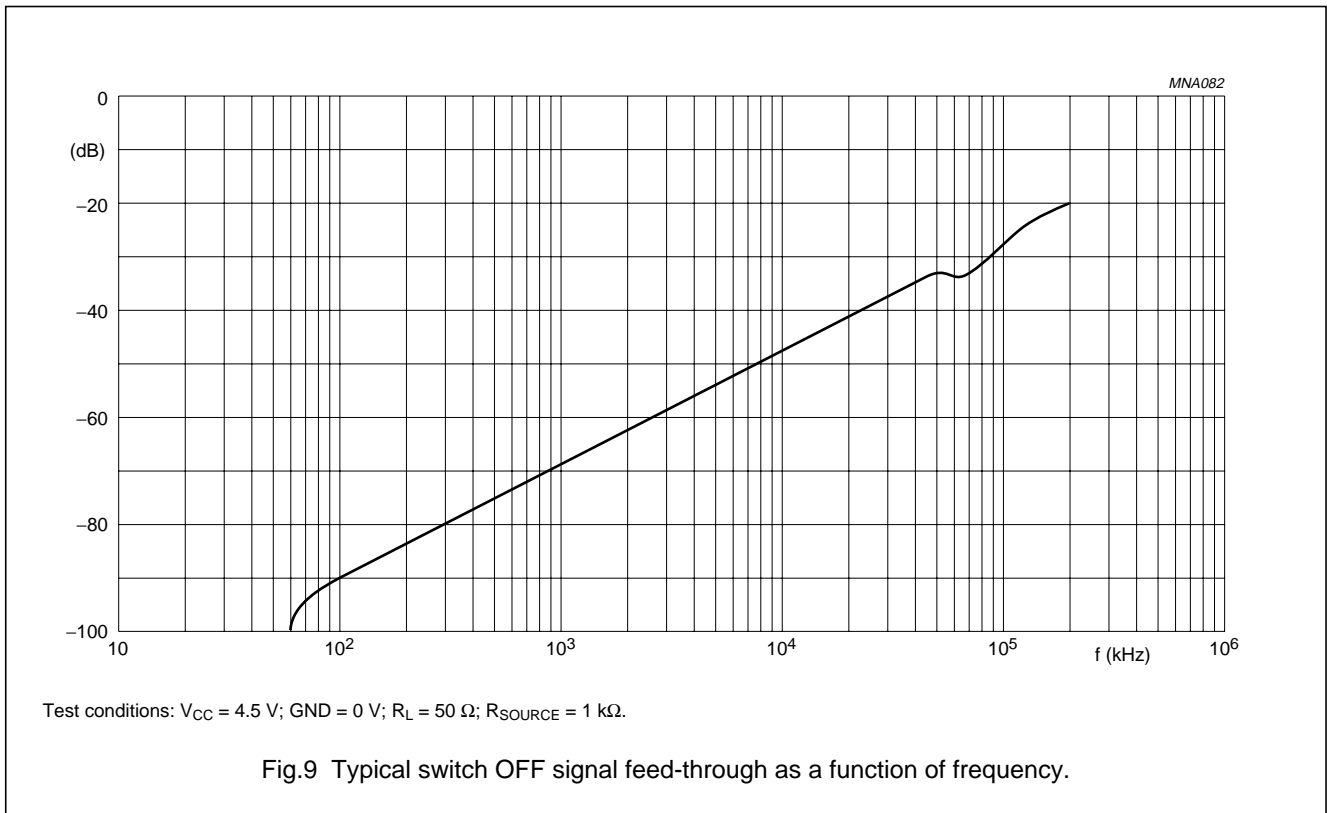

Bilateral switches

74HC2G66; 74HCT2G66

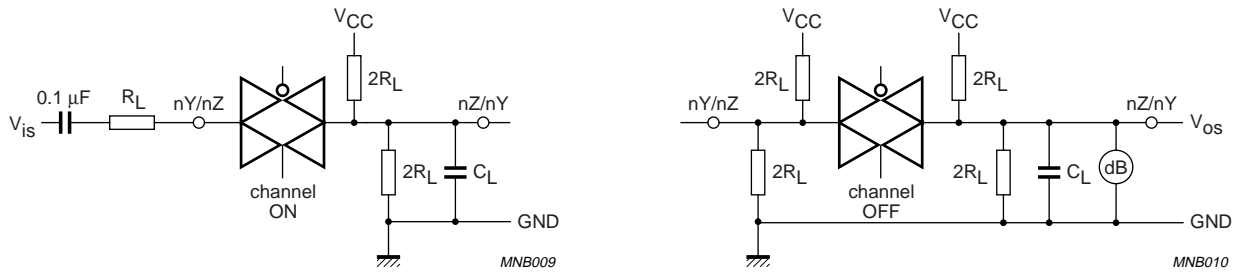

a. Channel ON condition.

b. Channel OFF condition.

Fig.11 Test circuit for measuring crosstalk between any two switches.

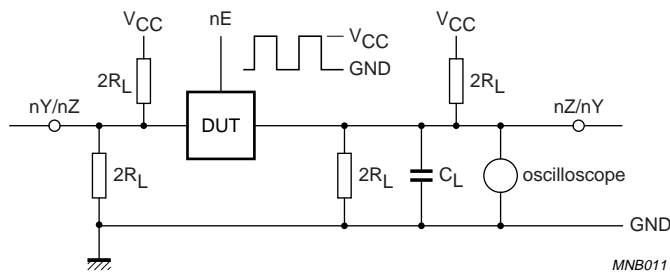

The crosstalk is defined as follows (oscilloscope output):

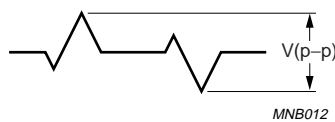
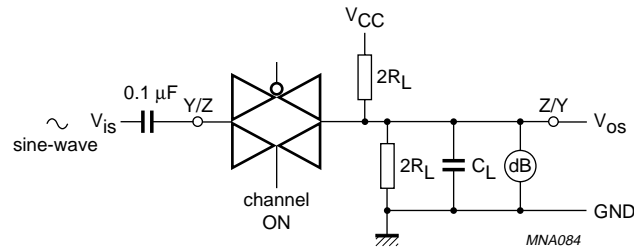

Fig.12 Test circuit for measuring crosstalk between control and any switch.

Bilateral switches

74HC2G66; 74HCT2G66



Adjust input voltage to obtain 0 dBm at V_{os} when $f_i = 1$ MHz.
 After set-up, frequency of f_i is increased to obtain a reading of -3 dB at V_{os} .

Fig.13 Test circuit for measuring minimum frequency response.

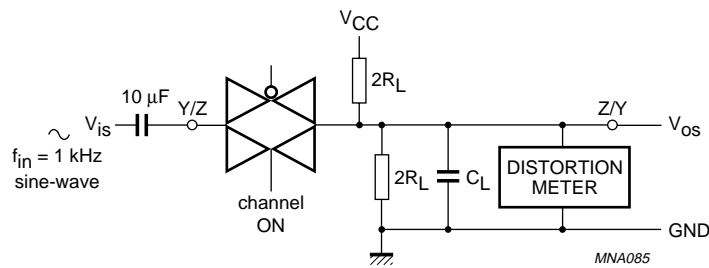

Fig.14 Test circuit for measuring sine-wave distortion.

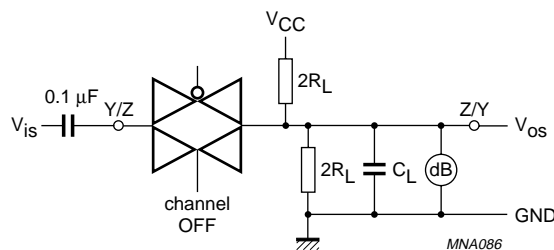
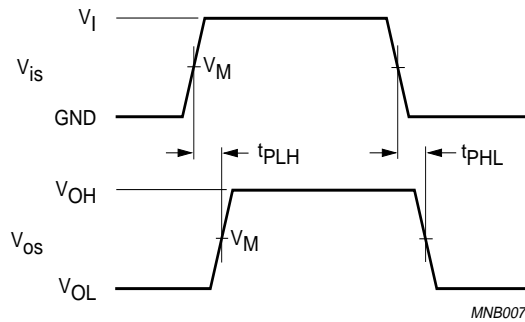

Fig.15 Test circuit for measuring switch OFF signal feed-through.

Bilateral switches

74HC2G66; 74HCT2G66

AC WAVEFORMS



74HC2G66: $V_M = 50\%$; $V_I = \text{GND to } V_{CC}$.
 74HCT2G66: $V_M = 1.3 \text{ V}$; $V_I = \text{GND to } 3.0 \text{ V}$.

Fig.16 Waveforms showing input (V_{is}) to output (V_{os}) propagation delay and the output transition time.

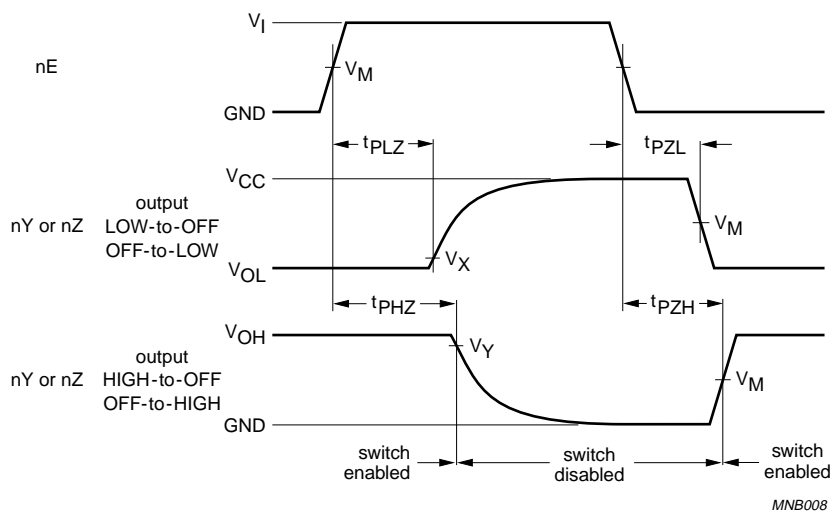

$V_X = 10\%$ of signal amplitude.
 $V_Y = 90\%$ of signal amplitude.
 74HC2G66: $V_M = 50\%$; $V_I = \text{GND to } V_{CC}$.
 74HCT2G66: $V_M = 1.3 \text{ V}$; $V_I = \text{GND to } 3.0 \text{ V}$.

Fig.17 Waveforms showing turn-on and turn-off times.

Bilateral switches

74HC2G66; 74HCT2G66

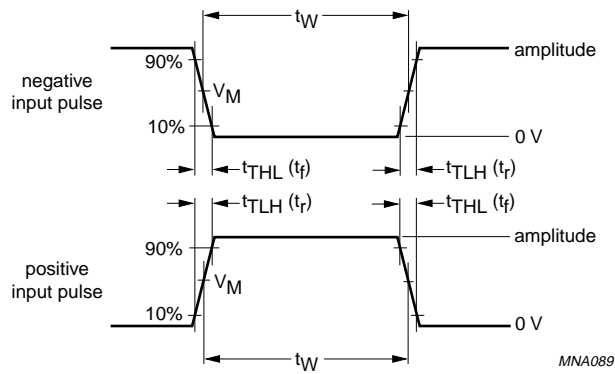

Input pulse definition:

$t_r = t_f = 6$ ns, when measuring f_{max} , there is no constraint on t_r, t_f with 50% duty factor.

74HC2G66: $V_M = 50\%$; $V_I = \text{GND to } V_{CC}$.

74HCT2G66: $V_M = 1.3$ V; $V_I = \text{GND to } 3.0$ V.

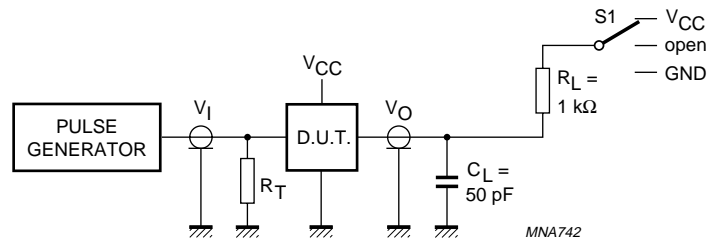

TEST	S1
t_{PLH}/t_{PHL}	open
t_{PLZ}/t_{PZL}	V_{CC}
t_{PHZ}/t_{PZH}	GND

Definitions for test circuit:

R_L = Load resistor.

C_L = Load capacitance including jig and probe capacitance.

R_T = Termination resistance should be equal to the output impedance Z_o of the pulse generator.

Fig.18 Load circuitry for switching times.

Bilateral switches

74HC2G66; 74HCT2G66

PACKAGE OUTLINE

TSSOP8: plastic thin shrink small outline package; 8 leads; body width 3 mm; lead length 0.5 mm SOT505-2

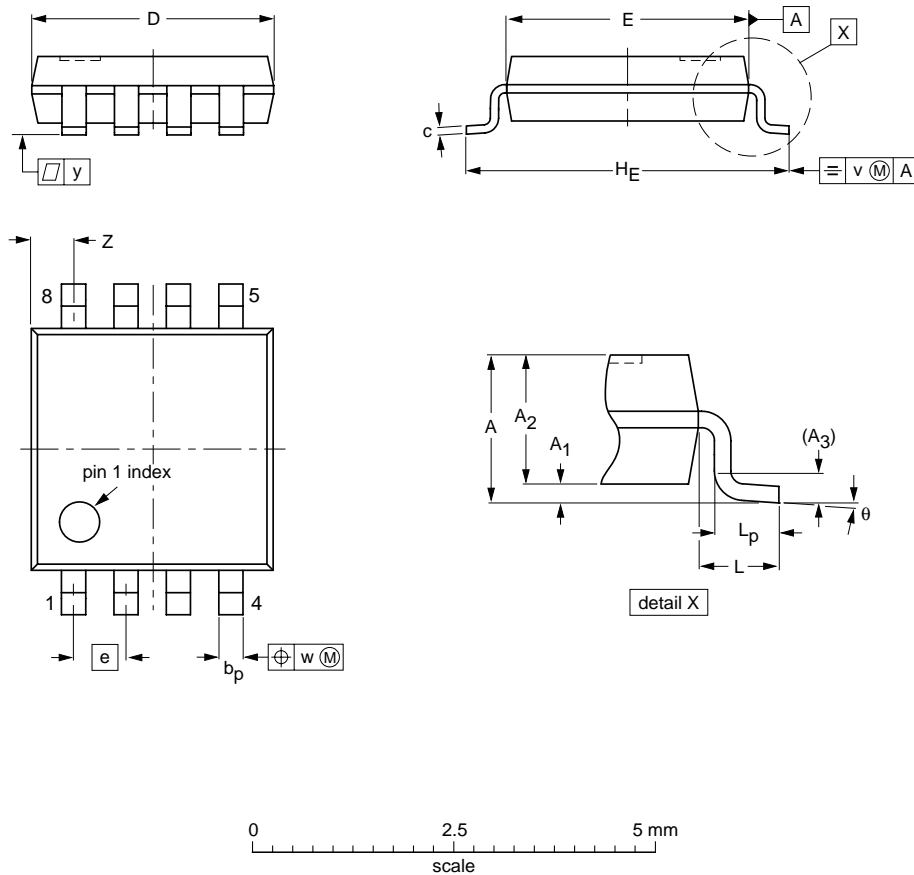

DIMENSIONS (mm are the original dimensions)

UNIT	A max.	A ₁	A ₂	A ₃	b _p	c	D ⁽¹⁾	E ⁽¹⁾	e	H _E	L	L _p	v	w	y	z ⁽¹⁾	θ
mm	1.1	0.15 0.00	0.95 0.75	0.25	0.38 0.22	0.18 0.08	3.1 2.9	3.1 2.9	0.65	4.1 3.9	0.5	0.47 0.33	0.2	0.13	0.1	0.70 0.35	8° 0°

Note

1. Plastic or metal protrusions of 0.15 mm maximum per side are not included.

OUTLINE VERSION	REFERENCES				EUROPEAN PROJECTION	ISSUE DATE
	IEC	JEDEC	JEITA			
SOT505-2		---				02-01-16

Bilateral switches

74HC2G66; 74HCT2G66

DATA SHEET STATUS

LEVEL	DATA SHEET STATUS ⁽¹⁾	PRODUCT STATUS ⁽²⁾⁽³⁾	DEFINITION
I	Objective data	Development	This data sheet contains data from the objective specification for product development. Philips Semiconductors reserves the right to change the specification in any manner without notice.
II	Preliminary data	Qualification	This data sheet contains data from the preliminary specification. Supplementary data will be published at a later date. Philips Semiconductors reserves the right to change the specification without notice, in order to improve the design and supply the best possible product.
III	Product data	Production	This data sheet contains data from the product specification. Philips Semiconductors reserves the right to make changes at any time in order to improve the design, manufacturing and supply. Relevant changes will be communicated via a Customer Product/Process Change Notification (CPCN).

Notes

1. Please consult the most recently issued data sheet before initiating or completing a design.
2. The product status of the device(s) described in this data sheet may have changed since this data sheet was published. The latest information is available on the Internet at URL <http://www.semiconductors.philips.com>.
3. For data sheets describing multiple type numbers, the highest-level product status determines the data sheet status.

DEFINITIONS

Short-form specification — The data in a short-form specification is extracted from a full data sheet with the same type number and title. For detailed information see the relevant data sheet or data handbook.

Limiting values definition — Limiting values given are in accordance with the Absolute Maximum Rating System (IEC 60134). Stress above one or more of the limiting values may cause permanent damage to the device. These are stress ratings only and operation of the device at these or at any other conditions above those given in the Characteristics sections of the specification is not implied. Exposure to limiting values for extended periods may affect device reliability.

Application information — Applications that are described herein for any of these products are for illustrative purposes only. Philips Semiconductors make no representation or warranty that such applications will be suitable for the specified use without further testing or modification.

DISCLAIMERS

Life support applications — These products are not designed for use in life support appliances, devices, or systems where malfunction of these products can reasonably be expected to result in personal injury. Philips Semiconductors customers using or selling these products for use in such applications do so at their own risk and agree to fully indemnify Philips Semiconductors for any damages resulting from such application.

Right to make changes — Philips Semiconductors reserves the right to make changes in the products - including circuits, standard cells, and/or software - described or contained herein in order to improve design and/or performance. When the product is in full production (status 'Production'), relevant changes will be communicated via a Customer Product/Process Change Notification (CPCN). Philips Semiconductors assumes no responsibility or liability for the use of any of these products, conveys no licence or title under any patent, copyright, or mask work right to these products, and makes no representations or warranties that these products are free from patent, copyright, or mask work right infringement, unless otherwise specified.

Philips Semiconductors – a worldwide company

Contact information

For additional information please visit <http://www.semiconductors.philips.com>. Fax: **+31 40 27 24825**

For sales offices addresses send e-mail to: sales.addresses@www.semiconductors.philips.com.

© Koninklijke Philips Electronics N.V. 2004

SCA76

All rights are reserved. Reproduction in whole or in part is prohibited without the prior written consent of the copyright owner.

The information presented in this document does not form part of any quotation or contract, is believed to be accurate and reliable and may be changed without notice. No liability will be accepted by the publisher for any consequence of its use. Publication thereof does not convey nor imply any license under patent- or other industrial or intellectual property rights.

Printed in The Netherlands

R44/04/pp20

Date of release: 2004 May 19

Document order number: 9397 750 13255

Let's make things better.

**Philips
Semiconductors**



PHILIPS