

74HC73

Dual JK flip-flop with reset; negative-edge trigger

Rev. 03 — 12 November 2004

Product data sheet

1. General description

The 74HC73 is a high-speed Si-gate CMOS device and is pin compatible with low-power Schottky TTL (LSTTL). The 74HC73 is specified in compliance with JEDEC standard no. 7A.

The 74HC is a dual negative-edge triggered JK flip-flop featuring individual J, K, clock (\overline{nCP}) and reset (\overline{nR}) inputs; also complementary nQ and $n\overline{Q}$ outputs.

The J and K inputs must be stable one set-up time prior to the HIGH-to-LOW clock transition for predictable operation.

The reset (\overline{nR}) is an asynchronous active LOW input. When LOW, it overrides the clock and data inputs, forcing the nQ output LOW and the $n\overline{Q}$ output HIGH.

Schmitt-trigger action in the clock input makes the circuit highly tolerant to slower clock rise and fall times.

2. Features

- Low-power dissipation
- Complies with JEDEC standard no. 7A
- ESD protection:
 - ◆ HBM EIA/JESD22-A114-B exceeds 2000 V
 - ◆ MM EIA/JESD22-A115-A exceeds 200 V.
- Multiple package options
- Specified from $-40\text{ }^{\circ}\text{C}$ to $+80\text{ }^{\circ}\text{C}$ and from $-40\text{ }^{\circ}\text{C}$ to $+125\text{ }^{\circ}\text{C}$.

PHILIPS

3. Quick reference data

Table 1: Quick reference data

$GND = 0\text{ V}$; $T_{amb} = 25\text{ °C}$; $t_r = t_f = 6\text{ ns}$.

Symbol	Parameter	Conditions	Min	Typ	Max	Unit
t_{PHL} , t_{PLH}	propagation delay	$C_L = 15\text{ pF}$; $V_{CC} = 5\text{ V}$	-		-	
	$n\overline{CP}$ to nQ		-	16	-	ns
	$n\overline{CP}$ to $n\overline{Q}$		-	16	-	ns
	$n\overline{R}$ to nQ , $n\overline{Q}$		-	15	-	ns
f_{max}	maximum clock frequency	$C_L = 15\text{ pF}$; $V_{CC} = 5\text{ V}$	-	77	-	MHz
C_I	input capacitance		-	3.5	-	pF
C_{PD}	power dissipation capacitance per flip-flop	$V_I = GND$ to V_{CC}	[1]	30	-	pF

[1] C_{PD} is used to determine the dynamic power dissipation (P_D in μW).

$$P_D = C_{PD} \times V_{CC}^2 \times f_i \times N + \sum(C_L \times V_{CC}^2 \times f_o) \text{ where:}$$

f_i = input frequency in MHz;

f_o = output frequency in MHz;

C_L = output load capacitance in pF;

V_{CC} = supply voltage in V;

N = number of inputs switching;

$\sum(C_L \times V_{CC}^2 \times f_o)$ = sum of outputs.

4. Ordering information

Table 2: Ordering information

Type number	Package			
	Temperature range	Name	Description	Version
74HC73N	-40 °C to +125 °C	DIP14	plastic dual in-line package; 14 leads (300 mil)	SOT27-1
74HC73D	-40 °C to +125 °C	SO14	plastic small outline package; 14 leads; body width 3.9 mm	SOT108-1
74HC73DB	-40 °C to +125 °C	SSOP14	plastic shrink small outline package; 14 leads; body width 5.3 mm	SOT337-1
74HC73PW	-40 °C to +125 °C	TSSOP14	plastic thin shrink small outline package; 14 leads; body width 4.4 mm	SOT402-1

5. Functional diagram

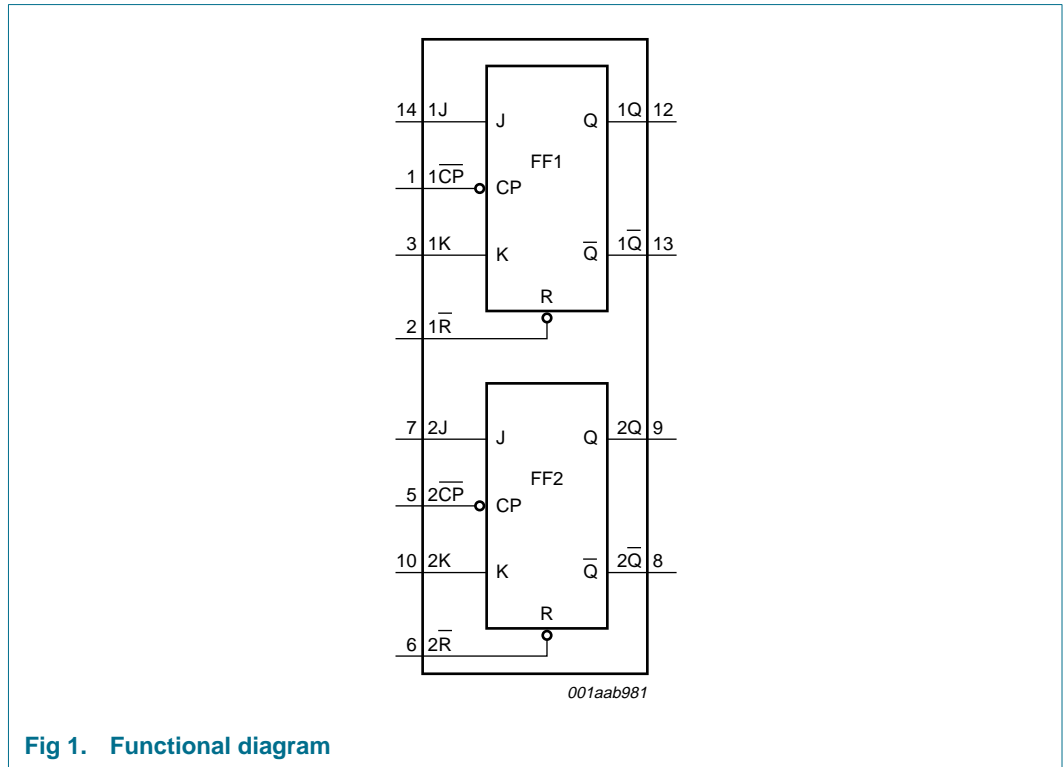

Fig 1. Functional diagram

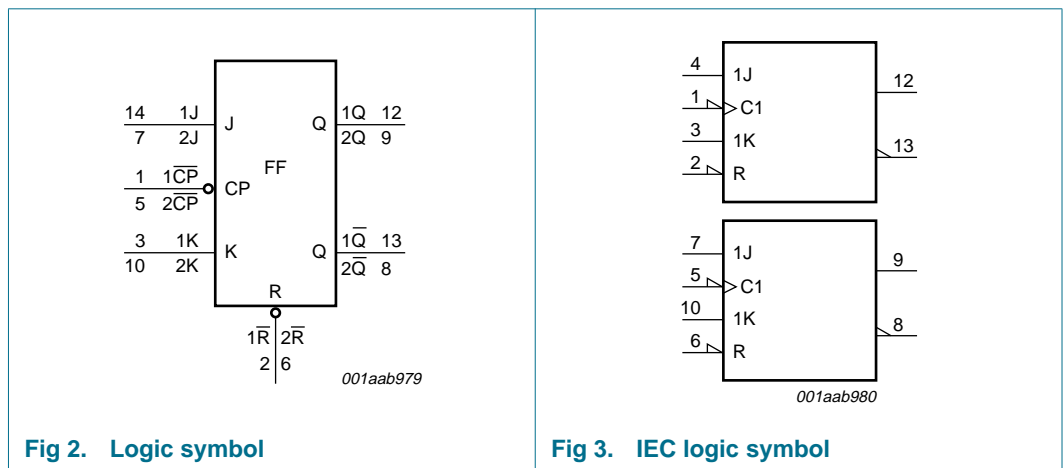
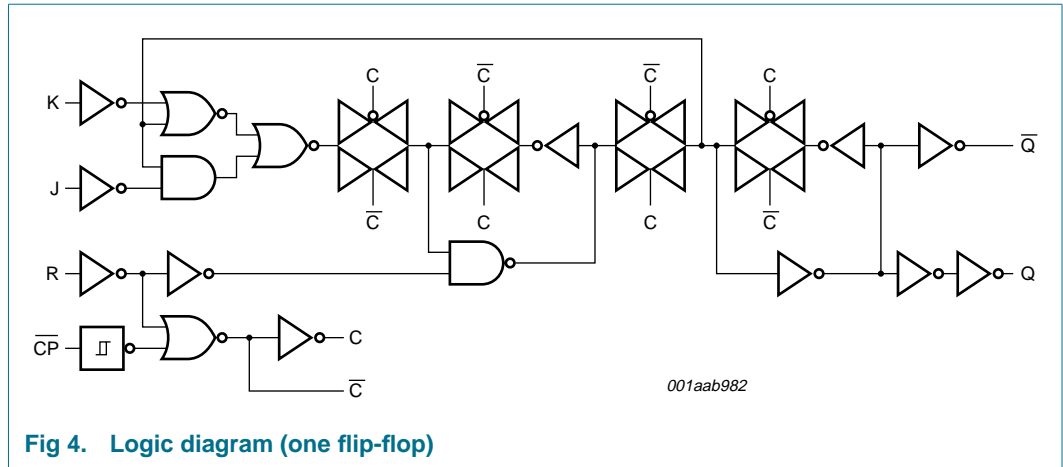

Fig 2. Logic symbol

Fig 3. IEC logic symbol



6. Pinning information

6.1 Pinning

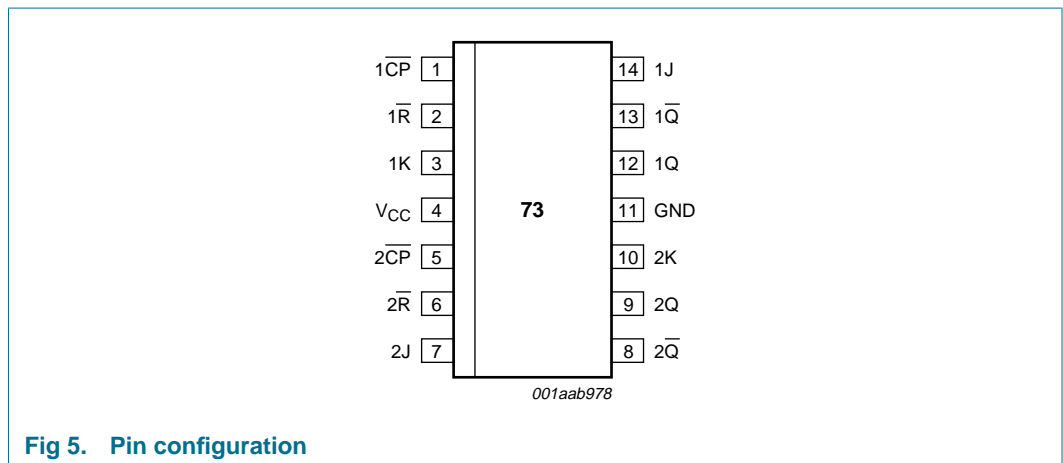

6.2 Pin description

Table 3: Pin description

Symbol	Pin	Description
$1\overline{CP}$	1	clock input for flip-flop 1 (HIGH-to-LOW, edge-triggered)
$1\overline{R}$	2	asynchronous reset input for flip-flop 1 (active LOW)
1K	3	synchronous K input for flip-flop 1
V_{CC}	4	positive supply voltage
$2\overline{CP}$	5	clock input for flip-flop 2 (HIGH-to-LOW, edge-triggered)
$2\overline{R}$	6	asynchronous reset input for flip-flop 2 (active LOW)
2J	7	synchronous J input for flip-flop 2
$2\overline{Q}$	8	complement flip-flop 2 output
2Q	9	true flip-flop 2 output
2K	10	synchronous K input for flip-flop 2

Table 3: Pin description ...continued

Symbol	Pin	Description
GND	11	ground (0 V)
1Q	12	true flip-flop 1 output
1 \bar{Q}	13	complement flip-flop 1 output
1J	14	synchronous J input for flip-flop 1

7. Functional description

7.1 Function table

Table 4: Function table [1]

Input				Output		Operating mode
n \bar{R}	n \bar{CP}	nJ	nK	nQ	n \bar{Q}	
L	X	X	X	L	H	asynchronous reset
H	↓	h	h	\bar{q}	q	toggle
		l	h	L	H	load 0 (reset)
		h	l	H	L	load 1 (set)
		l	l	q	\bar{q}	hold (no change)

- [1] H = HIGH voltage level;
h = HIGH voltage level one set-up time prior to the HIGH-to-LOW CP transition;
L = LOW voltage level;
l = LOW voltage level one set-up time prior to the HIGH-to-LOW CP transition;
q = state of referenced output one set-up time prior to the HIGH-to-LOW CP transition;
X = don't care;
↓ = HIGH-to-LOW CP transition.

8. Limiting values

Table 5: Limiting values

In accordance with the Absolute Maximum Rating System (IEC 60134). Voltages are referenced to GND (ground = 0 V).

Symbol	Parameter	Conditions	Min	Max	Unit
V_{CC}	supply voltage		-0.5	+7	V
I_{IK}	input diode current	$V_I < -0.5$ V or $V_I > V_{CC} + 0.5$ V	-	±20	mA
I_{OK}	output diode current	$V_O < -0.5$ V or $V_O > V_{CC} + 0.5$ V	-	±20	mA
I_O	output source or sink current	$V_O = -0.5$ V to $V_{CC} + 0.5$ V	-	±25	mA
I_{CC}, I_{GND}	V_{CC} or GND current		-	±50	mA
T_{stg}	storage temperature		-65	+150	°C
P_{tot}	power dissipation				
	DIP14 package		[1]	-	750 mW
	SO14, SSOP14 and TSSOP14 packages		[2]	-	500 mW

[1] Above 70 °C: P_{tot} derates linearly with 12 mW/K.

[2] Above 70 °C: P_{tot} derates linearly with 8 mW/K.

9. Recommended operating conditions

Table 6: Recommended operating conditions

Symbol	Parameter	Conditions	Min	Typ	Max	Unit
V_{CC}	supply voltage		2.0	5.0	6.0	V
V_I	input voltage		0	-	V_{CC}	V
V_O	output voltage		0	-	V_{CC}	V
t_r, t_f	input rise and fall times except for nCP	$V_{CC} = 2.0\text{ V}$	-	-	1000	ns
		$V_{CC} = 4.5\text{ V}$	-	6.0	500	ns
		$V_{CC} = 6.0\text{ V}$	-	-	400	ns
T_{amb}	ambient temperature		-40	-	+125	°C

10. Static characteristics

Table 7: Static characteristics

At recommended operating conditions; voltages are referenced to GND (ground = 0 V).

Symbol	Parameter	Conditions	Min	Typ	Max	Unit
$T_{amb} = 25\text{ °C}$						
V_{IH}	HIGH-level input voltage	$V_{CC} = 2.0\text{ V}$	1.5	1.2	-	V
		$V_{CC} = 4.5\text{ V}$	3.15	2.4	-	V
		$V_{CC} = 6.0\text{ V}$	4.2	3.2	-	V
V_{IL}	LOW-level input voltage	$V_{CC} = 2.0\text{ V}$	-	0.8	0.5	V
		$V_{CC} = 4.5\text{ V}$	-	2.1	1.35	V
		$V_{CC} = 6.0\text{ V}$	-	2.8	1.8	V
V_{OH}	HIGH-level output voltage	$V_I = V_{IH}$ or V_{IL}				
		$I_O = -20\text{ }\mu\text{A}; V_{CC} = 2.0\text{ V}$	1.9	2.0	-	V
		$I_O = -20\text{ }\mu\text{A}; V_{CC} = 4.5\text{ V}$	4.4	4.5	-	V
		$I_O = -20\text{ }\mu\text{A}; V_{CC} = 6.0\text{ V}$	5.9	6.0	-	V
		$I_O = -4\text{ mA}; V_{CC} = 4.5\text{ V}$	3.98	4.32	-	V
V_{OL}	LOW-level output voltage	$V_I = V_{IH}$ or V_{IL}				
		$I_O = 20\text{ }\mu\text{A}; V_{CC} = 2.0\text{ V}$	-	0	0.1	V
		$I_O = 20\text{ }\mu\text{A}; V_{CC} = 4.5\text{ V}$	-	0	0.1	V
		$I_O = 20\text{ }\mu\text{A}; V_{CC} = 6.0\text{ V}$	-	0	0.1	V
		$I_O = 4\text{ mA}; V_{CC} = 4.5\text{ V}$	-	0.15	0.26	V
	$I_O = 5.2\text{ mA}; V_{CC} = 6.0\text{ V}$	-	0.16	0.26	V	
I_{LI}	input leakage current	$V_I = V_{CC}$ or GND; $V_{CC} = 6.0\text{ V}$	-	-	± 0.1	μA
I_{CC}	quiescent supply current	$V_I = V_{CC}$ or GND; $I_O = 0\text{ A}; V_{CC} = 6.0\text{ V}$	-	-	4.0	μA
C_I	input capacitance		-	3.5	-	pF

Table 7: Static characteristics ...continued

At recommended operating conditions; voltages are referenced to GND (ground = 0 V).

Symbol	Parameter	Conditions	Min	Typ	Max	Unit
T_{amb} = -40 °C to +85 °C						
V _{IH}	HIGH-level input voltage	V _{CC} = 2.0 V	1.5	-	-	V
		V _{CC} = 4.5 V	3.15	-	-	V
		V _{CC} = 6.0 V	4.2	-	-	V
V _{IL}	LOW-level input voltage	V _{CC} = 2.0 V	-	-	0.5	V
		V _{CC} = 4.5 V	-	-	1.35	V
		V _{CC} = 6.0 V	-	-	1.8	V
V _{OH}	HIGH-level output voltage	V _I = V _{IH} or V _{IL}				
		I _O = -20 μA; V _{CC} = 2.0 V	1.9	-	-	V
		I _O = -20 μA; V _{CC} = 4.5 V	4.4	-	-	V
		I _O = -20 μA; V _{CC} = 6.0 V	5.9	-	-	V
		I _O = -4 mA; V _{CC} = 4.5 V	3.84	-	-	V
		I _O = -5.2 mA; V _{CC} = 6.0 V	5.34	-	-	V
V _{OL}	LOW-level output voltage	V _I = V _{IH} or V _{IL}				
		I _O = 20 μA; V _{CC} = 2.0 V	-	-	0.1	V
		I _O = 20 μA; V _{CC} = 4.5 V	-	-	0.1	V
		I _O = 20 μA; V _{CC} = 6.0 V	-	-	0.1	V
		I _O = 4 mA; V _{CC} = 4.5 V	-	-	0.33	V
		I _O = 5.2 mA; V _{CC} = 6.0 V	-	-	0.33	V
I _{LI}	input leakage current	V _I = V _{CC} or GND; V _{CC} = 6.0 V	-	-	±1.0	μA
I _{CC}	quiescent supply current	V _I = V _{CC} or GND; I _O = 0 A; V _{CC} = 6.0 V	-	-	40.0	μA

Table 7: Static characteristics ...continued

At recommended operating conditions; voltages are referenced to GND (ground = 0 V).

Symbol	Parameter	Conditions	Min	Typ	Max	Unit
$T_{amb} = -40\text{ °C to }+125\text{ °C}$						
V_{IH}	HIGH-level input voltage	$V_{CC} = 2.0\text{ V}$	1.5	-	-	V
		$V_{CC} = 4.5\text{ V}$	3.15	-	-	V
		$V_{CC} = 6.0\text{ V}$	4.2	-	-	V
V_{IL}	LOW-level input voltage	$V_{CC} = 2.0\text{ V}$	-	-	0.5	V
		$V_{CC} = 4.5\text{ V}$	-	-	1.35	V
		$V_{CC} = 6.0\text{ V}$	-	-	1.8	V
V_{OH}	HIGH-level output voltage	$V_I = V_{IH}$ or V_{IL}				
		$I_O = -20\text{ }\mu\text{A}; V_{CC} = 2.0\text{ V}$	1.9	-	-	V
		$I_O = -20\text{ }\mu\text{A}; V_{CC} = 4.5\text{ V}$	4.4	-	-	V
		$I_O = -20\text{ }\mu\text{A}; V_{CC} = 6.0\text{ V}$	5.9	-	-	V
		$I_O = -4\text{ mA}; V_{CC} = 4.5\text{ V}$	3.7	-	-	V
V_{OL}	LOW-level output voltage	$V_I = V_{IH}$ or V_{IL}				
		$I_O = 20\text{ }\mu\text{A}; V_{CC} = 2.0\text{ V}$	-	-	0.1	V
		$I_O = 20\text{ }\mu\text{A}; V_{CC} = 4.5\text{ V}$	-	-	0.1	V
		$I_O = 20\text{ }\mu\text{A}; V_{CC} = 6.0\text{ V}$	-	-	0.1	V
		$I_O = 4\text{ mA}; V_{CC} = 4.5\text{ V}$	-	-	0.4	V
I_{LI}	input leakage current	$V_I = V_{CC}$ or GND; $V_{CC} = 6.0\text{ V}$	-	-	± 1.0	μA
		$V_I = V_{CC}$ or GND; $I_O = 0\text{ A}; V_{CC} = 6.0\text{ V}$	-	-	80.0	μA

11. Dynamic characteristics

Table 8: Dynamic characteristics

$GND = 0\text{ V}$; $t_r = t_f = 6\text{ ns}$; $C_L = 50\text{ pF}$; see [Figure 8](#).

Symbol	Parameter	Conditions	Min	Typ	Max	Unit	
$T_{\text{amb}} = 25\text{ °C}$							
$t_{\text{PHL}}, t_{\text{PLH}}$	propagation delay \overline{nCP} to nQ	see Figure 6					
		$V_{\text{CC}} = 2.0\text{ V}$	-	52	160	ns	
		$V_{\text{CC}} = 4.5\text{ V}$	-	19	32	ns	
		$V_{\text{CC}} = 6.0\text{ V}$	-	15	27	ns	
	propagation delay \overline{nCP} to $n\overline{Q}$	see Figure 6					
		$V_{\text{CC}} = 2.0\text{ V}$	-	52	160	ns	
		$V_{\text{CC}} = 4.5\text{ V}$	-	19	32	ns	
		$V_{\text{CC}} = 6.0\text{ V}$	-	15	27	ns	
	propagation delay $n\overline{R}$ to $nQ, n\overline{Q}$	see Figure 7					
		$V_{\text{CC}} = 2.0\text{ V}$	-	50	145	ns	
		$V_{\text{CC}} = 4.5\text{ V}$	-	18	29	ns	
		$V_{\text{CC}} = 6.0\text{ V}$	-	14	25	ns	
$t_{\text{THL}}, t_{\text{TLH}}$	output transition time	see Figure 6					
		$V_{\text{CC}} = 2.0\text{ V}$	-	19	75	ns	
		$V_{\text{CC}} = 4.5\text{ V}$	-	7	15	ns	
		$V_{\text{CC}} = 6.0\text{ V}$	-	6	13	ns	
t_{W}	$n\overline{CP}$ clock pulse width HIGH or LOW	see Figure 6					
		$V_{\text{CC}} = 2.0\text{ V}$	80	22	-	ns	
		$V_{\text{CC}} = 4.5\text{ V}$	16	8	-	ns	
		$V_{\text{CC}} = 6.0\text{ V}$	14	6	-	ns	
	$n\overline{R}$ reset pulse width HIGH or LOW	see Figure 7					
		$V_{\text{CC}} = 2.0\text{ V}$	80	22	-	ns	
		$V_{\text{CC}} = 4.5\text{ V}$	16	8	-	ns	
		$V_{\text{CC}} = 6.0\text{ V}$	14	6	-	ns	
	t_{rem}	removal time $n\overline{R}$ to $n\overline{CP}$	see Figure 7				
			$V_{\text{CC}} = 2.0\text{ V}$	80	22	-	ns
			$V_{\text{CC}} = 4.5\text{ V}$	16	8	-	ns
			$V_{\text{CC}} = 6.0\text{ V}$	14	6	-	ns
t_{su}	set-up time nJ, nK to $n\overline{CP}$	see Figure 6					
		$V_{\text{CC}} = 2.0\text{ V}$	80	22	-	ns	
		$V_{\text{CC}} = 4.5\text{ V}$	16	8	-	ns	
		$V_{\text{CC}} = 6.0\text{ V}$	14	6	-	ns	

Table 8: Dynamic characteristics ...continued
 $GND = 0\text{ V}$; $t_r = t_f = 6\text{ ns}$; $C_L = 50\text{ pF}$; see [Figure 8](#).

Symbol	Parameter	Conditions	Min	Typ	Max	Unit	
t_h	hold time nJ, nK to nCP	see Figure 6					
		$V_{CC} = 2.0\text{ V}$	3	-8	-	ns	
		$V_{CC} = 4.5\text{ V}$	3	-3	-	ns	
		$V_{CC} = 6.0\text{ V}$	3	-2	-	ns	
f_{max}	maximum clock frequency	see Figure 6					
		$V_{CC} = 2.0\text{ V}$	6.0	23	-	MHz	
		$V_{CC} = 4.5\text{ V}$	30	70	-	MHz	
		$V_{CC} = 6.0\text{ V}$	35	83	-	MHz	
		$V_{CC} = 5.0\text{ V}$; $C_L = 15\text{ pF}$	-	77	-	MHz	
C_{PD}	power dissipation capacitance per flip-flop	$V_I = GND$ to V_{CC}	[1] -	30	-	pF	
$T_{amb} = -40\text{ °C}$ to $+85\text{ °C}$							
t_{PHL} , t_{PLH}	propagation delay nCP to nQ	see Figure 6					
		$V_{CC} = 2.0\text{ V}$	-	-	200	ns	
		$V_{CC} = 4.5\text{ V}$	-	-	40	ns	
	propagation delay nCP to nQ	$V_{CC} = 6.0\text{ V}$	-	-	34	ns	
		see Figure 6					
		$V_{CC} = 2.0\text{ V}$	-	-	200	ns	
	propagation delay nCP to nQ	$V_{CC} = 4.5\text{ V}$	-	-	40	ns	
		$V_{CC} = 6.0\text{ V}$	-	-	34	ns	
		propagation delay nR to nQ, nQ	see Figure 7				
	$V_{CC} = 2.0\text{ V}$		-	-	180	ns	
	$V_{CC} = 4.5\text{ V}$		-	-	36	ns	
	propagation delay nR to nQ, nQ	$V_{CC} = 6.0\text{ V}$	-	-	31	ns	
t_{THL} , t_{TLH}		output transition time	see Figure 6				
			$V_{CC} = 2.0\text{ V}$	-	-	95	ns
	$V_{CC} = 4.5\text{ V}$		-	-	19	ns	
	$V_{CC} = 6.0\text{ V}$		-	-	16	ns	
t_w	nCP clock pulse width HIGH or LOW	see Figure 6					
		$V_{CC} = 2.0\text{ V}$	100	-	-	ns	
		$V_{CC} = 4.5\text{ V}$	20	-	-	ns	
	nR reset pulse width HIGH or LOW	$V_{CC} = 6.0\text{ V}$	17	-	-	ns	
		see Figure 7					
		$V_{CC} = 2.0\text{ V}$	100	-	-	ns	
	nR reset pulse width HIGH or LOW	$V_{CC} = 4.5\text{ V}$	20	-	-	ns	
		$V_{CC} = 6.0\text{ V}$	17	-	-	ns	
		t_{rem}	removal time nR to nCP	see Figure 7			
	$V_{CC} = 2.0\text{ V}$			100	-	-	ns
	$V_{CC} = 4.5\text{ V}$			20	-	-	ns
	$V_{CC} = 6.0\text{ V}$			17	-	-	ns

Table 8: Dynamic characteristics ...continued
 $GND = 0\text{ V}$; $t_r = t_f = 6\text{ ns}$; $C_L = 50\text{ pF}$; see [Figure 8](#).

Symbol	Parameter	Conditions	Min	Typ	Max	Unit	
t_{su}	set-up time nJ, nK to \overline{nCP}	see Figure 6					
		$V_{CC} = 2.0\text{ V}$	100	-	-	ns	
		$V_{CC} = 4.5\text{ V}$	20	-	-	ns	
		$V_{CC} = 6.0\text{ V}$	17	-	-	ns	
t_h	hold time nJ, nK to \overline{nCP}	see Figure 6					
		$V_{CC} = 2.0\text{ V}$	3	-	-	ns	
		$V_{CC} = 4.5\text{ V}$	3	-	-	ns	
		$V_{CC} = 6.0\text{ V}$	3	-	-	ns	
f_{max}	maximum clock frequency	see Figure 6					
		$V_{CC} = 2.0\text{ V}$	4.8	-	-	MHz	
		$V_{CC} = 4.5\text{ V}$	24	-	-	MHz	
		$V_{CC} = 6.0\text{ V}$	28	-	-	MHz	
$T_{amb} = -40\text{ °C to }+125\text{ °C}$							
t_{PHL}, t_{PLH}	propagation delay \overline{nCP} to nQ	see Figure 6					
		$V_{CC} = 2.0\text{ V}$	-	-	240	ns	
		$V_{CC} = 4.5\text{ V}$	-	-	48	ns	
	propagation delay \overline{nCP} to \overline{nQ}	see Figure 6					
		$V_{CC} = 2.0\text{ V}$	-	-	240	ns	
		$V_{CC} = 4.5\text{ V}$	-	-	48	ns	
	propagation delay \overline{nR} to nQ, \overline{nQ}	see Figure 7					
		$V_{CC} = 2.0\text{ V}$	-	-	220	ns	
		$V_{CC} = 4.5\text{ V}$	-	-	44	ns	
	t_{THL}, t_{TLH}	output transition time	see Figure 6				
			$V_{CC} = 2.0\text{ V}$	-	-	110	ns
			$V_{CC} = 4.5\text{ V}$	-	-	22	ns
t_w	\overline{nCP} clock pulse width HIGH or LOW	see Figure 6					
		$V_{CC} = 2.0\text{ V}$	120	-	-	ns	
		$V_{CC} = 4.5\text{ V}$	24	-	-	ns	
	\overline{nR} reset pulse width HIGH or LOW	see Figure 7					
		$V_{CC} = 2.0\text{ V}$	120	-	-	ns	
		$V_{CC} = 4.5\text{ V}$	24	-	-	ns	
	$V_{CC} = 6.0\text{ V}$	20	-	-	ns		

Table 8: Dynamic characteristics ...continued
GND = 0 V; $t_r = t_f = 6$ ns; $C_L = 50$ pF; see [Figure 8](#).

Symbol	Parameter	Conditions	Min	Typ	Max	Unit
t_{rem}	removal time $n\bar{R}$ to $n\bar{CP}$	see Figure 7				
		$V_{CC} = 2.0$ V	120	-	-	ns
		$V_{CC} = 4.5$ V	24	-	-	ns
		$V_{CC} = 6.0$ V	20	-	-	ns
t_{su}	set-up time nJ, nK to $n\bar{CP}$	see Figure 6				
		$V_{CC} = 2.0$ V	120	-	-	ns
		$V_{CC} = 4.5$ V	24	-	-	ns
		$V_{CC} = 6.0$ V	20	-	-	ns
t_h	hold time nJ, nK to $n\bar{CP}$	see Figure 6				
		$V_{CC} = 2.0$ V	3	-	-	ns
		$V_{CC} = 4.5$ V	3	-	-	ns
		$V_{CC} = 6.0$ V	3	-	-	ns
f_{max}	maximum clock frequency	see Figure 6				
		$V_{CC} = 2.0$ V	4.0	-	-	MHz
		$V_{CC} = 4.5$ V	20	-	-	MHz
		$V_{CC} = 6.0$ V	24	-	-	MHz

[1] C_{PD} is used to determine the dynamic power dissipation (P_D in μ W).

$$P_D = C_{PD} \times V_{CC}^2 \times f_i \times N + \sum(C_L \times V_{CC}^2 \times f_o) \text{ where:}$$

f_i = input frequency in MHz;

f_o = output frequency in MHz;

C_L = output load capacitance in pF;

V_{CC} = supply voltage in V;

N = number of inputs switching;

$\sum(C_L \times V_{CC}^2 \times f_o)$ = sum of outputs.

12. Waveforms

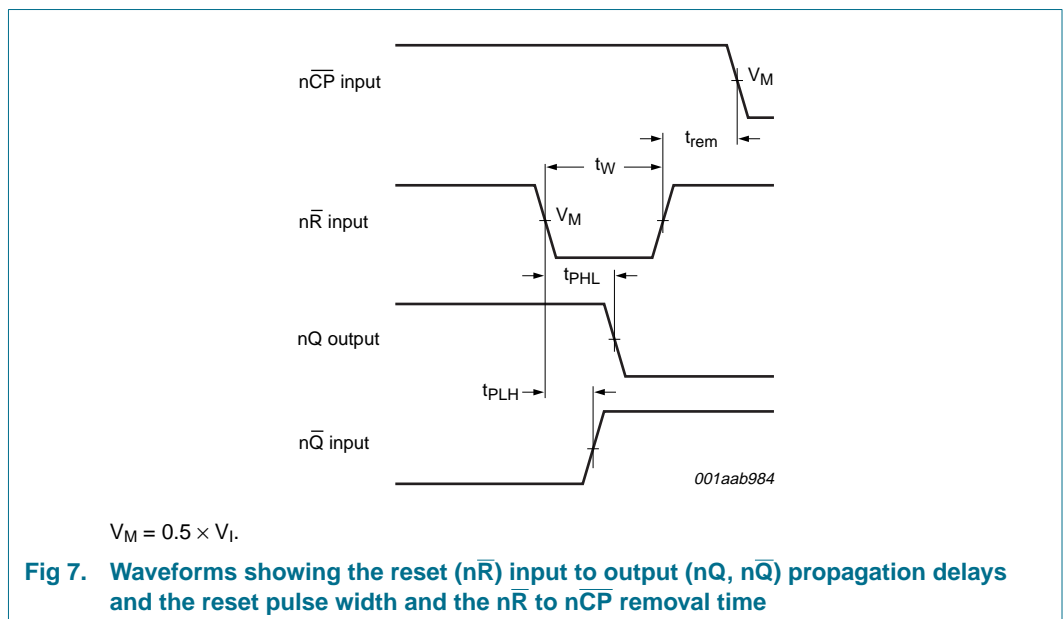
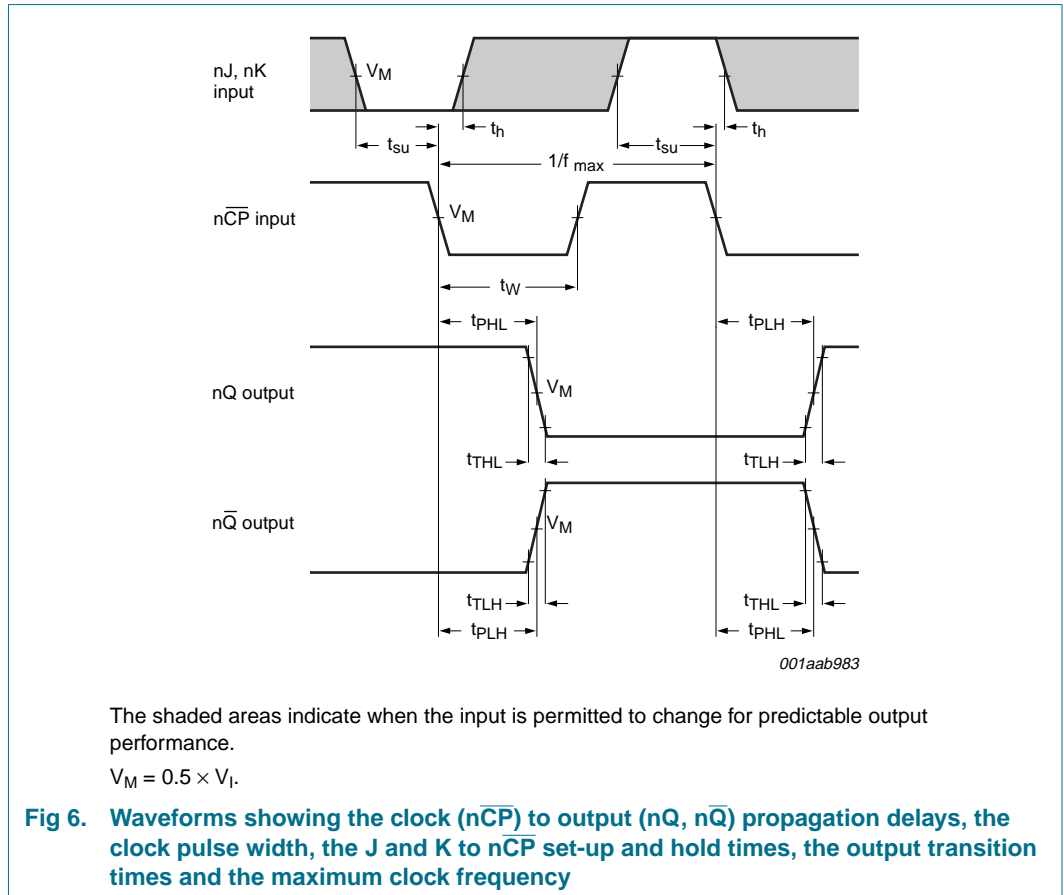

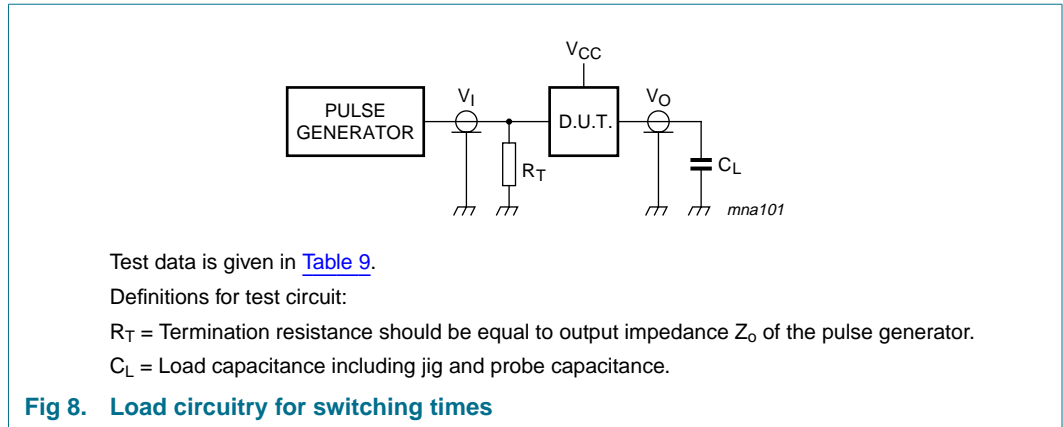

Table 9: Test data

Supply	Input		Load
V_{CC}	V_I	t_r, t_f	C_L
2.0 V	V_{CC}	6 ns	50 pF
4.5 V	V_{CC}	6 ns	50 pF
6.0 V	V_{CC}	6 ns	50 pF
5.0 V	V_{CC}	6 ns	15 pF

13. Package outline

DIP14: plastic dual in-line package; 14 leads (300 mil)

SOT27-1

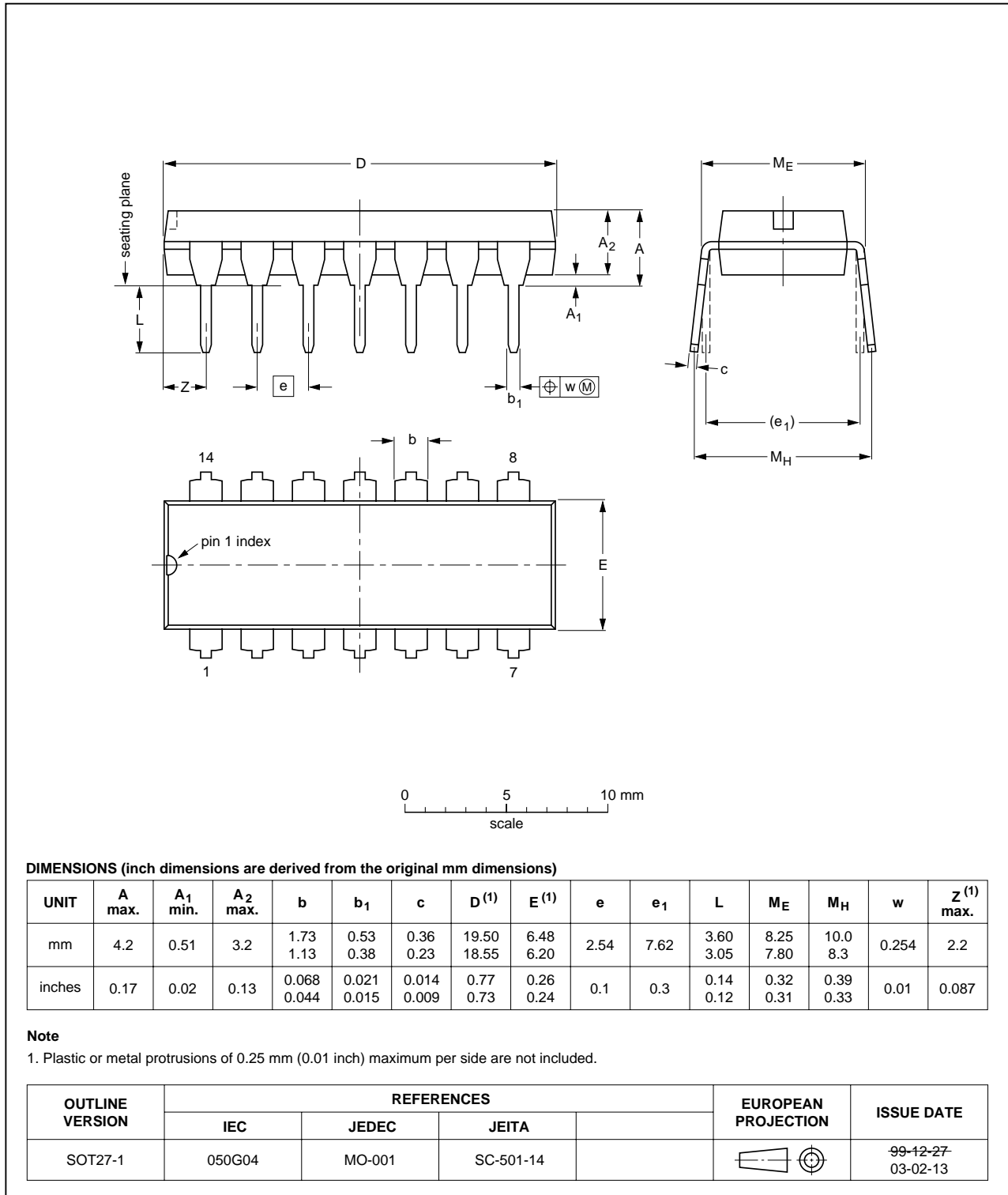

Fig 9. Package outline SOT27-1 (DIP14)

SO14: plastic small outline package; 14 leads; body width 3.9 mm

SOT108-1

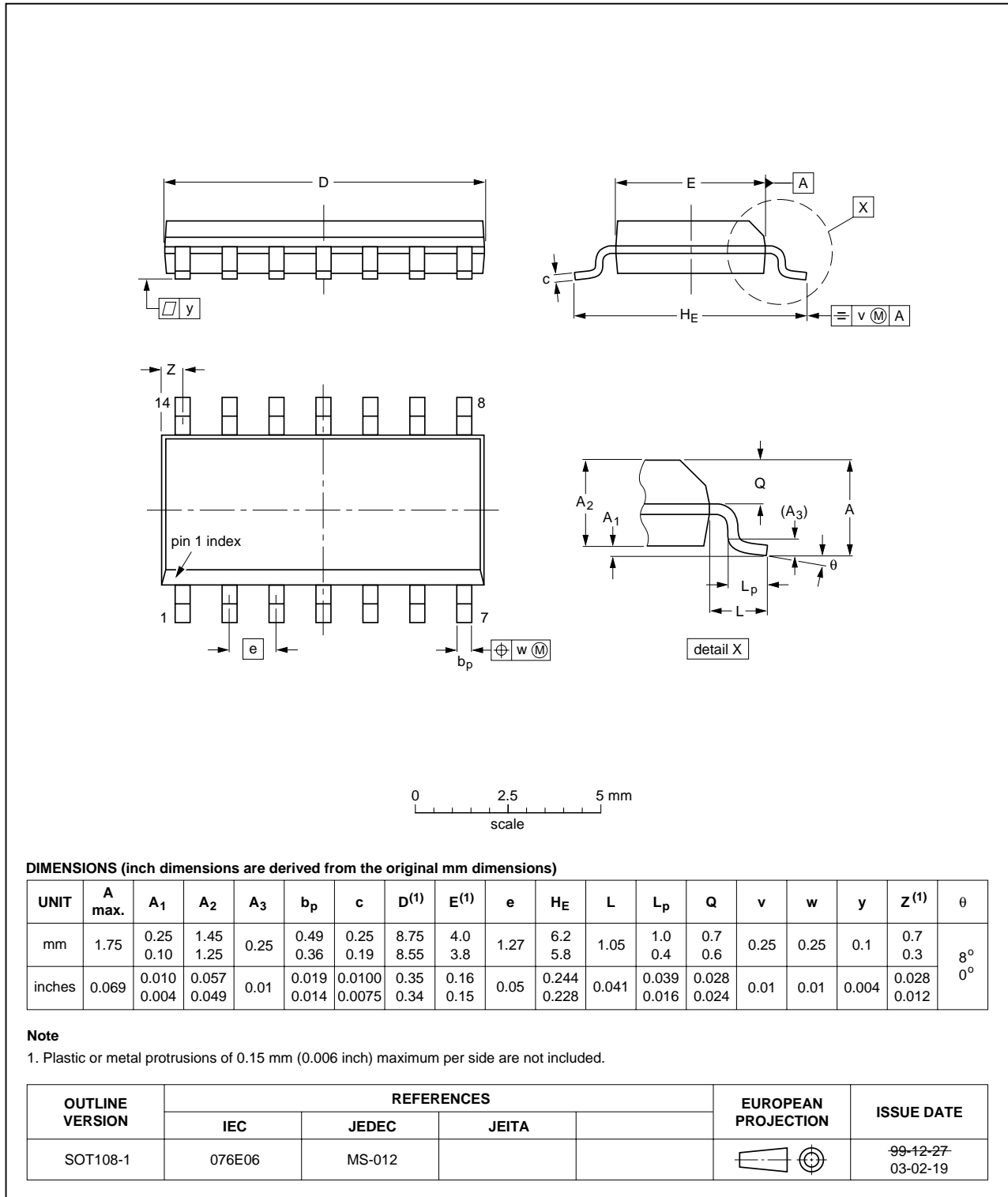

Fig 10. Package outline SOT108-1 (SO14)

SSOP14: plastic shrink small outline package; 14 leads; body width 5.3 mm

SOT337-1

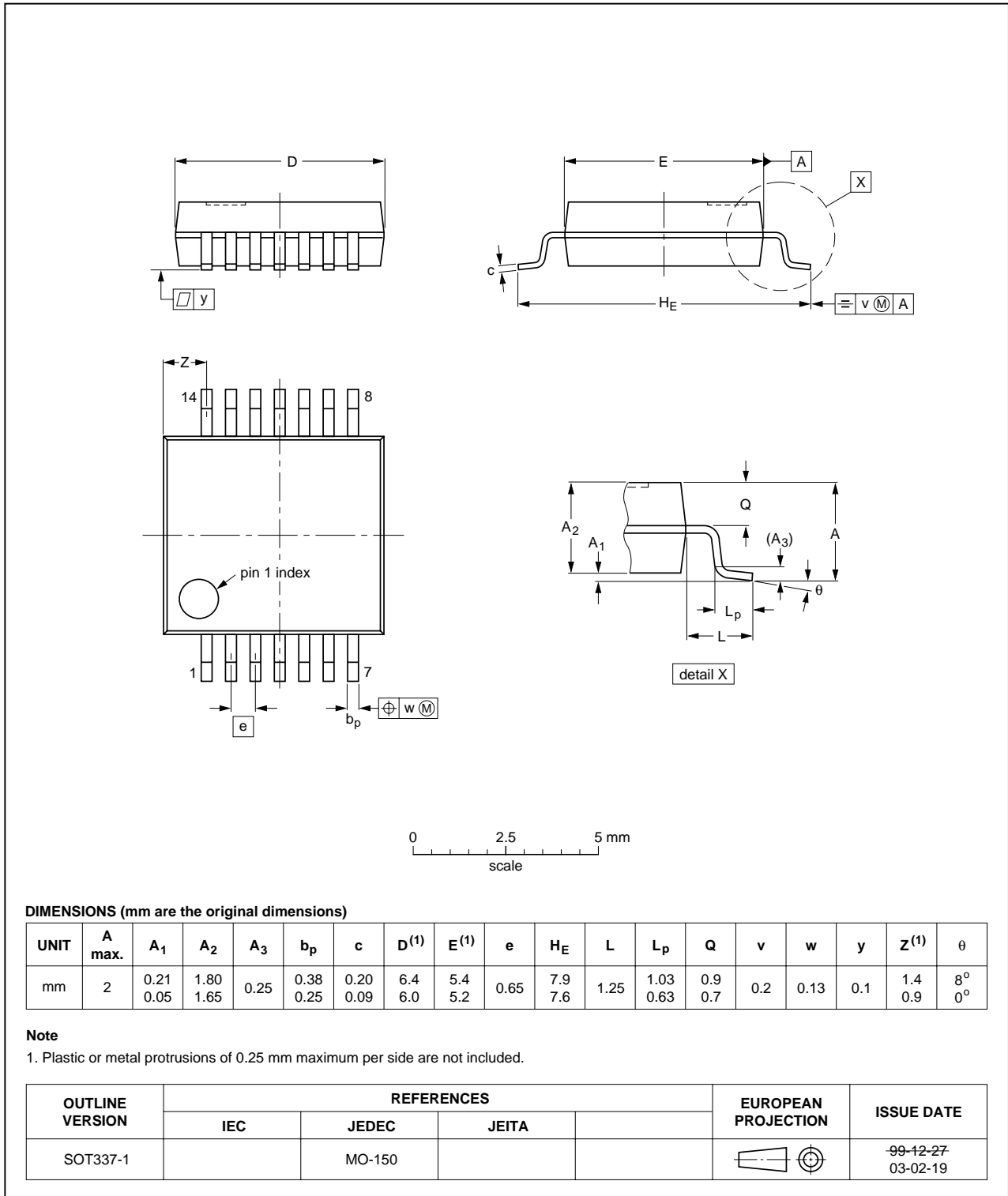

Fig 11. Package outline SOT337-1 (SSOP14)

TSSOP14: plastic thin shrink small outline package; 14 leads; body width 4.4 mm

SOT402-1

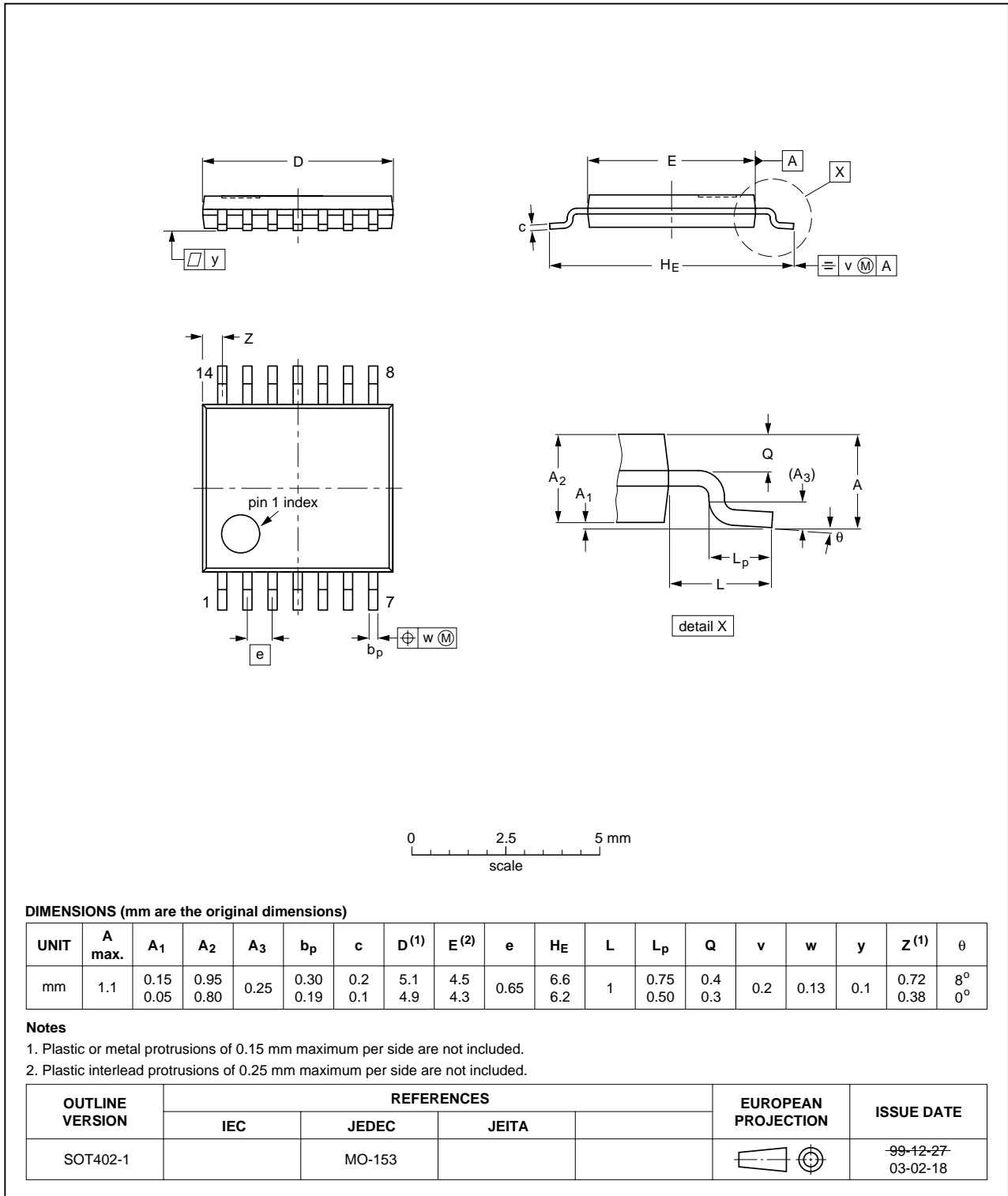

Fig 12. Package outline SOT402-1 (TSSOP14)

14. Revision history

Table 10: Revision history

Document ID	Release date	Data sheet status	Change notice	Doc. number	Supersedes
74HC73_3	20041112	Product data sheet	-	9397 750 13815	74HC_HCT73_CNV_2
Modifications:					
					<ul style="list-style-type: none">• The format of this data sheet has been redesigned to comply with the current presentation and information standard of Philips Semiconductors.• Removed type number 74HCT73.• Inserted family specification.
74HC_HCT73_CNV_2	19970911	Product specification	-	-	74HC_HCT73_1
74HC_HCT73_1	19901201	Product specification	-	-	-

15. Data sheet status

Level	Data sheet status ^[1]	Product status ^[2] ^[3]	Definition
I	Objective data	Development	This data sheet contains data from the objective specification for product development. Philips Semiconductors reserves the right to change the specification in any manner without notice.
II	Preliminary data	Qualification	This data sheet contains data from the preliminary specification. Supplementary data will be published at a later date. Philips Semiconductors reserves the right to change the specification without notice, in order to improve the design and supply the best possible product.
III	Product data	Production	This data sheet contains data from the product specification. Philips Semiconductors reserves the right to make changes at any time in order to improve the design, manufacturing and supply. Relevant changes will be communicated via a Customer Product/Process Change Notification (CPCN).

[1] Please consult the most recently issued data sheet before initiating or completing a design.

[2] The product status of the device(s) described in this data sheet may have changed since this data sheet was published. The latest information is available on the Internet at URL <http://www.semiconductors.philips.com>.

[3] For data sheets describing multiple type numbers, the highest-level product status determines the data sheet status.

16. Definitions

Short-form specification — The data in a short-form specification is extracted from a full data sheet with the same type number and title. For detailed information see the relevant data sheet or data handbook.

Limiting values definition — Limiting values given are in accordance with the Absolute Maximum Rating System (IEC 60134). Stress above one or more of the limiting values may cause permanent damage to the device. These are stress ratings only and operation of the device at these or at any other conditions above those given in the Characteristics sections of the specification is not implied. Exposure to limiting values for extended periods may affect device reliability.

Application information — Applications that are described herein for any of these products are for illustrative purposes only. Philips Semiconductors make no representation or warranty that such applications will be suitable for the specified use without further testing or modification.

17. Disclaimers

Life support — These products are not designed for use in life support appliances, devices, or systems where malfunction of these products can reasonably be expected to result in personal injury. Philips Semiconductors customers using or selling these products for use in such applications do so at their own risk and agree to fully indemnify Philips Semiconductors for any damages resulting from such application.

Right to make changes — Philips Semiconductors reserves the right to make changes in the products - including circuits, standard cells, and/or software - described or contained herein in order to improve design and/or performance. When the product is in full production (status 'Production'), relevant changes will be communicated via a Customer Product/Process Change Notification (CPCN). Philips Semiconductors assumes no responsibility or liability for the use of any of these products, conveys no license or title under any patent, copyright, or mask work right to these products, and makes no representations or warranties that these products are free from patent, copyright, or mask work right infringement, unless otherwise specified.

18. Contact information

For additional information, please visit: <http://www.semiconductors.philips.com>

For sales office addresses, send an email to: sales.addresses@www.semiconductors.philips.com

19. Contents

1	General description	1
2	Features	1
3	Quick reference data	2
4	Ordering information	2
5	Functional diagram	3
6	Pinning information	4
6.1	Pinning	4
6.2	Pin description	4
7	Functional description	5
7.1	Function table	5
8	Limiting values	5
9	Recommended operating conditions	6
10	Static characteristics	6
11	Dynamic characteristics	9
12	Waveforms	13
13	Package outline	15
14	Revision history	19
15	Data sheet status	20
16	Definitions	20
17	Disclaimers	20
18	Contact information	20



© Koninklijke Philips Electronics N.V. 2004

All rights are reserved. Reproduction in whole or in part is prohibited without the prior written consent of the copyright owner. The information presented in this document does not form part of any quotation or contract, is believed to be accurate and reliable and may be changed without notice. No liability will be accepted by the publisher for any consequence of its use. Publication thereof does not convey nor imply any license under patent- or other industrial or intellectual property rights.

Date of release: 12 November 2004
Document number: 9397 750 13815

Published in The Netherlands