

DATA SHEET

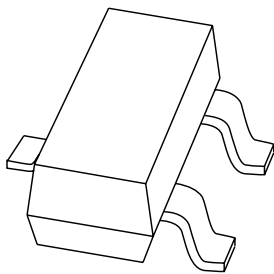

PESDxS2UT series

Double ESD protection diodes in
SOT23 package

Product specification
Supersedes data of 2003 Aug 20

2004 Apr 15

Double ESD protection diodes in SOT23 package

PESDxS2UT series

FEATURES

- Uni-directional ESD protection of up to two lines
- Max. peak pulse power: $P_{pp} = 330 \text{ W}$ at $t_p = 8/20 \mu\text{s}$
- Low clamping voltage: $V_{(CL)R} = 20 \text{ V}$ at $I_{pp} = 18 \text{ A}$
- Ultra-low reverse leakage current: $I_{RM} < 700 \text{ nA}$
- ESD protection $> 23 \text{ kV}$
- IEC 61000-4-2; level 4 (ESD)
- IEC 61000-4-5 (surge); $I_{pp} = 18 \text{ A}$ at $t_p = 8/20 \mu\text{s}$.

APPLICATIONS

- Computers and peripherals
- Communication systems
- Audio and video equipment
- High speed data lines
- Parallel ports.

DESCRIPTION

Uni-directional double ESD protection diodes in a SOT23 plastic package. Designed to protect up to two transmission or data lines from ElectroStatic Discharge (ESD) damage.

MARKING

TYPE NUMBER	MARKING CODE ⁽¹⁾
PESD3V3S2UT	*U9
PESD5V2S2UT	*U1
PESD12VS2UT	*U2
PESD15VS2UT	*U3
PESD24VS2UT	*U4

Note

1. * = p : made in Hong Kong.
 * = t : made in Malaysia.
 * = W : made in China.

QUICK REFERENCE DATA

SYMBOL	PARAMETER	VALUE	UNIT
V_{RWM}	reverse stand-off voltage	3.3, 5.2, 12, 15 and 24	V
C_d	diode capacitance $V_R = 0 \text{ V};$ $f = 1 \text{ MHz}$	207, 152, 38, 32 and 23	pF
	number of protected lines	2	

PINNING

PIN	DESCRIPTION
1	cathode 1
2	cathode 2
3	common anode

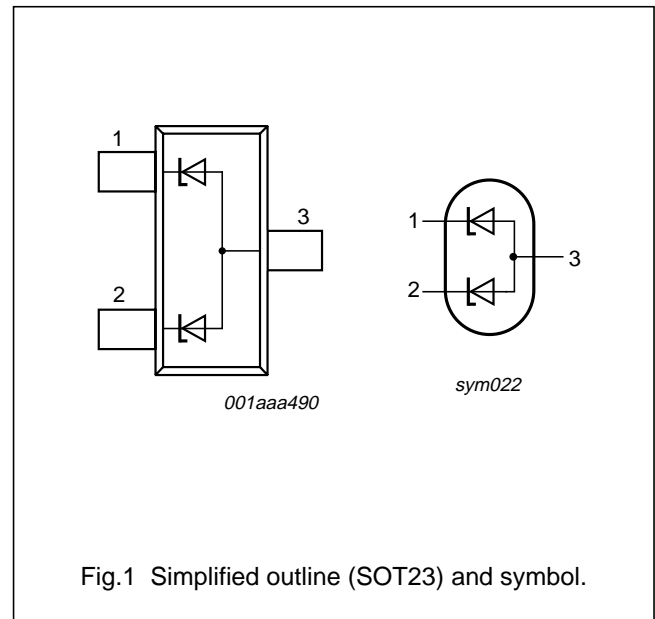

Double ESD protection diodes in SOT23 package

PESDxS2UT series

ORDERING INFORMATION

TYPE NUMBER	PACKAGE		
	NAME	DESCRIPTION	VERSION
PESD3V3S2UT	-	plastic surface mounted package; 3 leads	SOT23
PESD5V2S2UT			
PESD12VS2UT			
PESD15VS2UT			
PESD24VS2UT			

LIMITING VALUES

In accordance with the Absolute Maximum Rating System (IEC 60134).

SYMBOL	PARAMETER	CONDITIONS	MIN.	MAX.	UNIT
P _{pp}	peak pulse power	8/20 μ s pulse; notes 1 and 2	-	330	W
	PESD3V3S2UT				
	PESD5V2S2UT				
	PESD12VS2UT				
	PESD15VS2UT				
	PESD24VS2UT				
I _{pp}	peak pulse current	8/20 μ s pulse; notes 1 and 2	-	18	A
	PESD3V3S2UT				
	PESD5V2S2UT				
	PESD12VS2UT				
	PESD15VS2UT				
	PESD24VS2UT				
T _j	junction temperature		-	150	°C
T _{amb}	operating ambient temperature		-65	+150	°C
T _{stg}	storage temperature		-65	+150	°C

Notes

1. Non-repetitive current pulse 8/20 μ s exponential decay waveform; see Fig.2.
2. Measured across either pins 1 and 3 or pins 2 and 3.

Double ESD protection diodes in SOT23 package

PESDxS2UT series

ESD maximum ratings

SYMBOL	PARAMETER	CONDITIONS	VALUE	UNIT
ESD	electrostatic discharge capability	IEC 61000-4-2 (contact discharge); notes 1 and 2		
		PESD3V3S2UT	30	kV
		PESD5V2S2UT	30	kV
		PESD12VS2UT	30	kV
		PESD15VS2UT	30	kV
		PESD24VS2UT	23	kV
		HBM MIL-Std 883 PESDxS2UT series	10	kV

Notes

1. Device stressed with ten non-repetitive ElectroStatic Discharge (ESD) pulses; see Fig.3.
2. Measured across either pins 1 and 3 or pins 2 and 3.

ESD standards compliance

ESD STANDARD	CONDITIONS
IEC 61000-4-2; level 4 (ESD); see Fig.3	>15 kV (air); > 8 kV (contact)
HBM MIL-Std 883; class 3	>4 kV

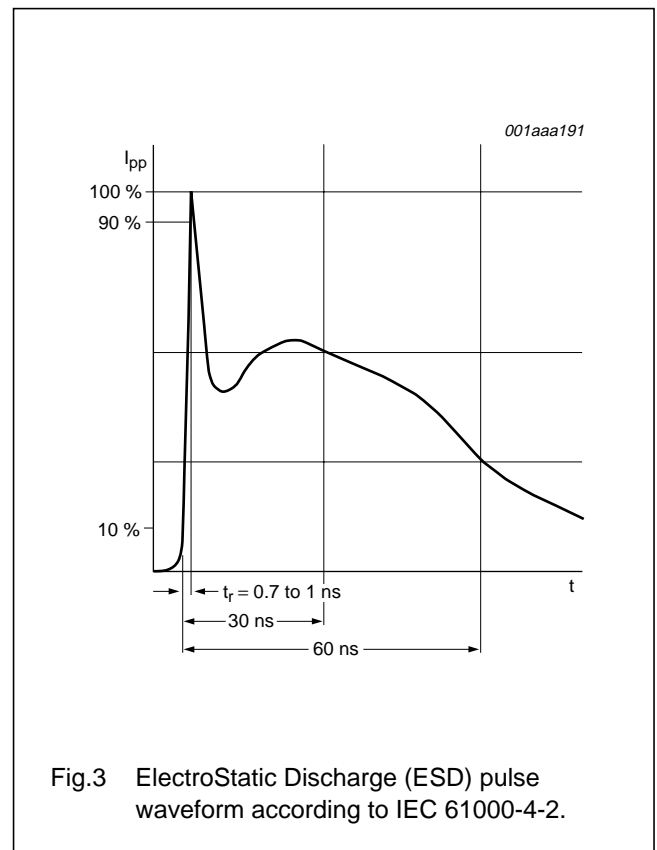
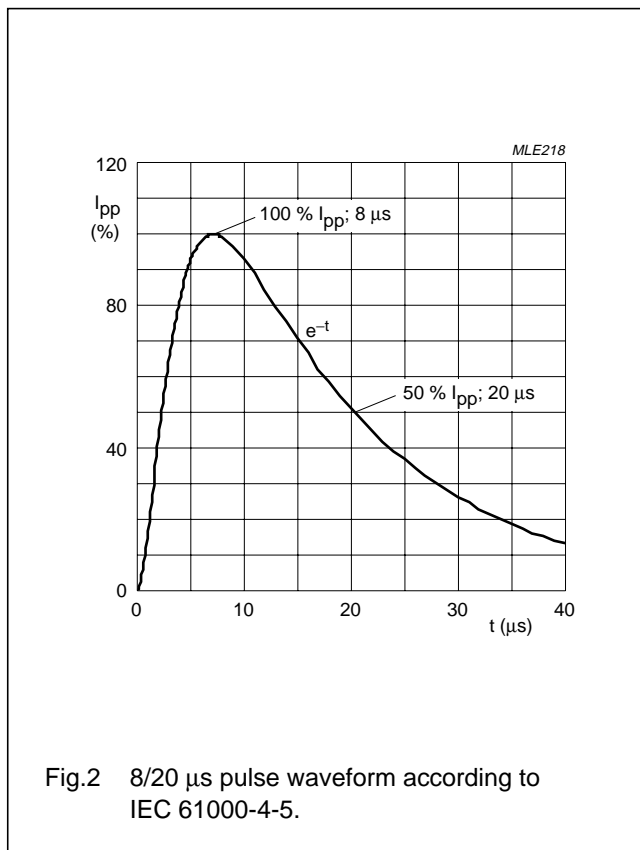

Double ESD protection diodes in SOT23 package

PESDxS2UT series

ELECTRICAL CHARACTERISTICS

$T_j = 25\text{ }^\circ\text{C}$ unless otherwise specified.

SYMBOL	PARAMETER	CONDITIONS	MIN.	TYP.	MAX.	UNIT
V_{RWM}	reverse stand-off voltage					
	PESD3V3S2UT		–	–	3.3	V
	PESD5V2S2UT		–	–	5.2	V
	PESD12VS2UT		–	–	12	V
	PESD15VS2UT		–	–	15	V
	PESD24VS2UT		–	–	24	V
I_{RM}	reverse leakage current					
	PESD3V3S2UT	$V_{RWM} = 3.3\text{ V}$	–	0.7	2	μA
	PESD5V2S2UT	$V_{RWM} = 5.2\text{ V}$	–	0.15	1	μA
	PESD12VS2UT	$V_{RWM} = 12\text{ V}$	–	<0.02	1	μA
	PESD15VS2UT	$V_{RWM} = 15\text{ V}$	–	<0.02	1	μA
	PESD24VS2UT	$V_{RWM} = 24\text{ V}$	–	<0.02	1	μA
V_{BR}	breakdown voltage	$I_Z = 5\text{ mA}$				
	PESD3V3S2UT		5.2	5.6	6.0	V
	PESD5V2S2UT		6.4	6.8	7.2	V
	PESD12VS2UT		14.7	15.0	15.3	V
	PESD15VS2UT		17.6	18.0	18.4	V
	PESD24VS2UT		26.5	27.0	27.5	V
C_d	diode capacitance	$f = 1\text{ MHz}; V_R = 0\text{ V}$				
	PESD3V3S2UT		–	207	300	pF
	PESD5V2S2UT		–	152	200	pF
	PESD12VS2UT		–	38	75	pF
	PESD15VS2UT		–	32	70	pF
	PESD24VS2UT		–	23	50	pF
$V_{(CL)R}$	clamping voltage	notes 1 and 2				
	PESD3V3S2UT	$I_{pp} = 1\text{ A}$	–	–	7	V
		$I_{pp} = 18\text{ A}$	–	–	20	V
	PESD5V2S2UT	$I_{pp} = 1\text{ A}$	–	–	9	V
		$I_{pp} = 15\text{ A}$	–	–	20	V
	PESD12VS2UT	$I_{pp} = 1\text{ A}$	–	–	19	V
		$I_{pp} = 5\text{ A}$	–	–	35	V
	PESD15VS2UT	$I_{pp} = 1\text{ A}$	–	–	23	V
		$I_{pp} = 5\text{ A}$	–	–	40	V
	PESD24VS2UT	$I_{pp} = 1\text{ A}$	–	–	36	V
$I_{pp} = 3\text{ A}$		–	–	70	V	

Double ESD protection diodes in SOT23 package

PESDxS2UT series

SYMBOL	PARAMETER	CONDITIONS	MIN.	TYP.	MAX.	UNIT
R _{diff}	differential resistance					
	PESD3V3S2UT	I _R = 1 mA	–	–	400	Ω
	PESD5V2S2UT	I _R = 1 mA	–	–	80	Ω
	PESD12VS2UT	I _R = 1 mA	–	–	200	Ω
	PESD15VS2UT	I _R = 1 mA	–	–	225	Ω
	PESD24VS2UT	I _R = 0.5 mA	–	–	300	Ω

Notes

1. Non-repetitive current pulse 8/20 μs exponential decay waveform; see Fig.2.
2. Measured either across pins 1 and 3 or pins 2 and 3.

GRAPHICAL DATA

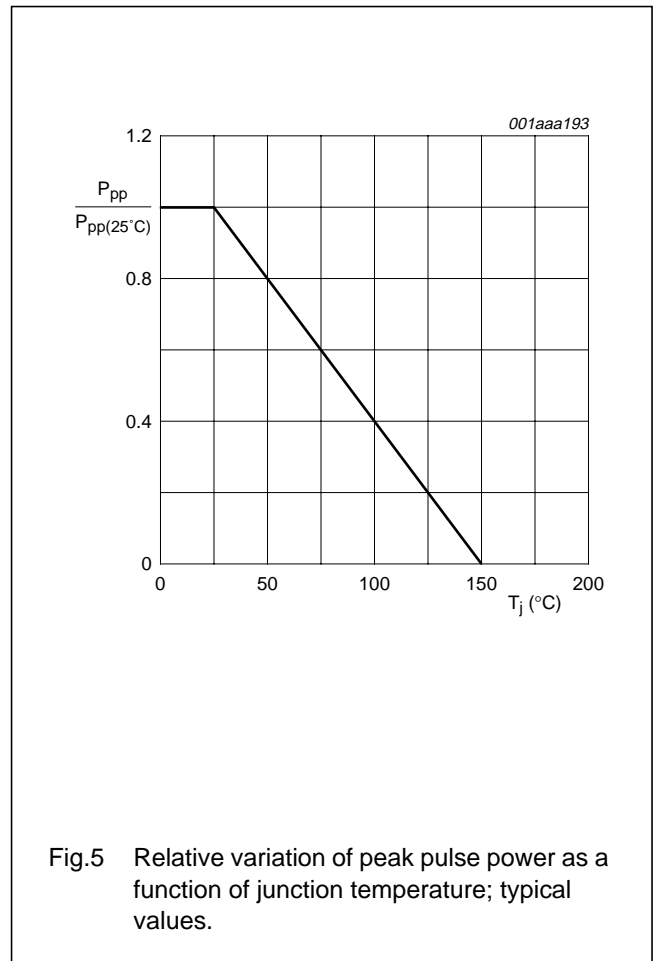
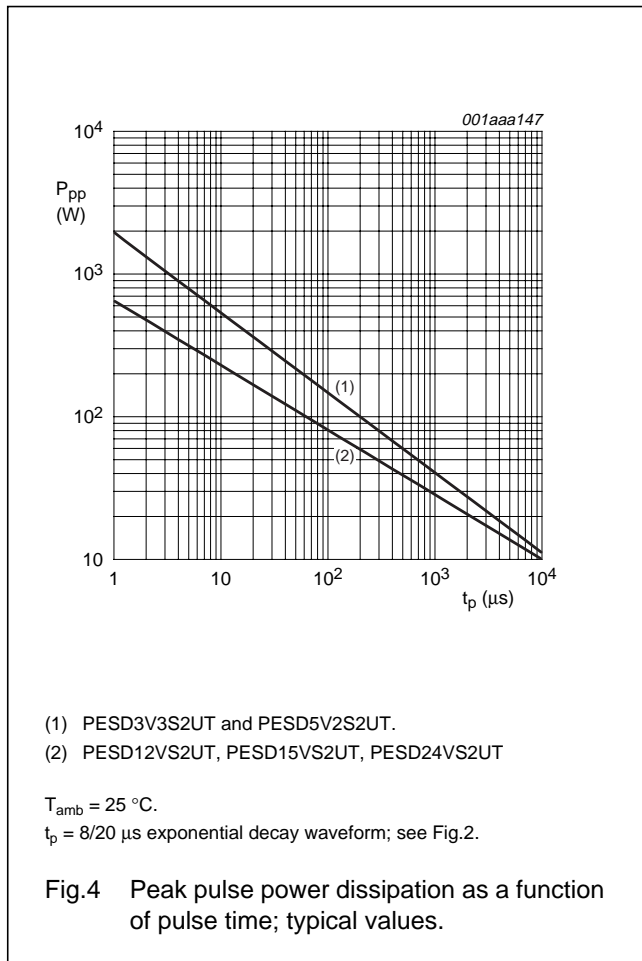

Double ESD protection diodes
in SOT23 package

PESDxS2UT series

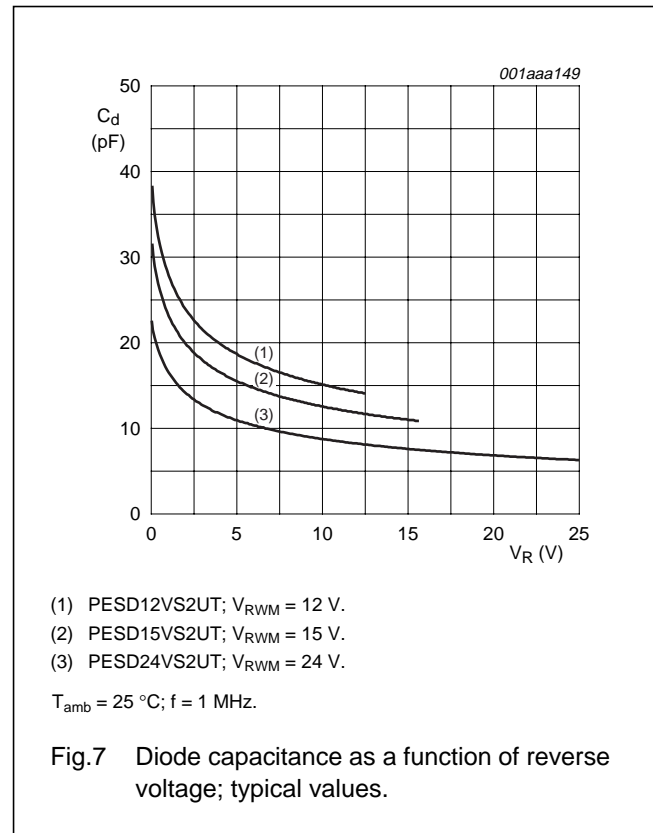
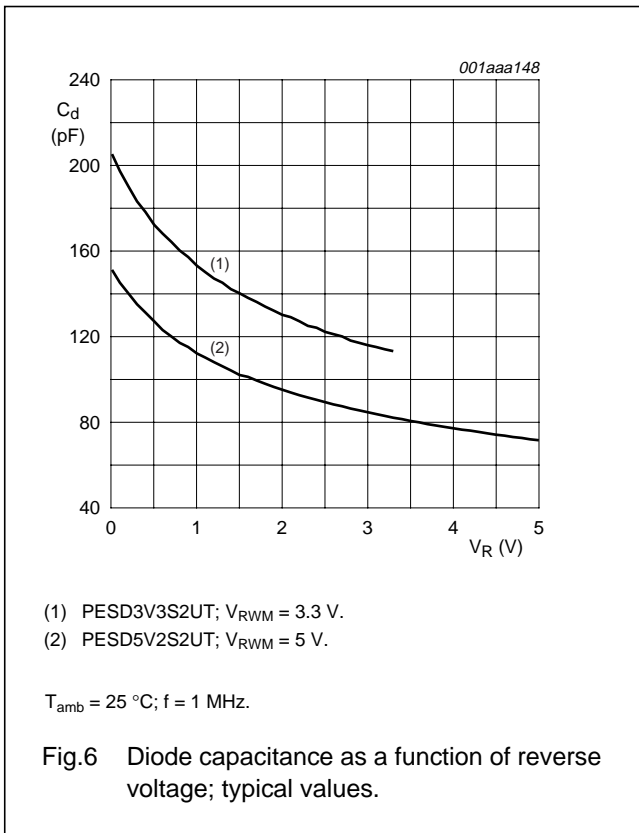

Double ESD protection diodes
in SOT23 package

PESDxS2UT series

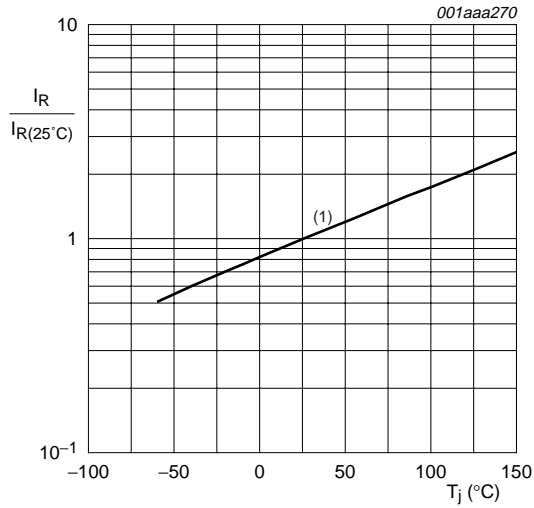

(1) PESD3V3S2UT; $V_{RWM} = 3.3$ V.
 PESD5V2S2UT; $V_{RWM} = 5$ V.

I_R is less than 10 nA at 150 °C for:
 PESD12V52UT; $V_{RWM} = 12$ V.
 PESD15VS2UT; $V_{RWM} = 15$ V.
 PESD24VS2UT; $V_{RWM} = 24$ V.

Fig.8 Relative variation of reverse leakage current as a function of junction temperature; typical values.

Double ESD protection diodes in SOT23 package

PESDxS2UT series

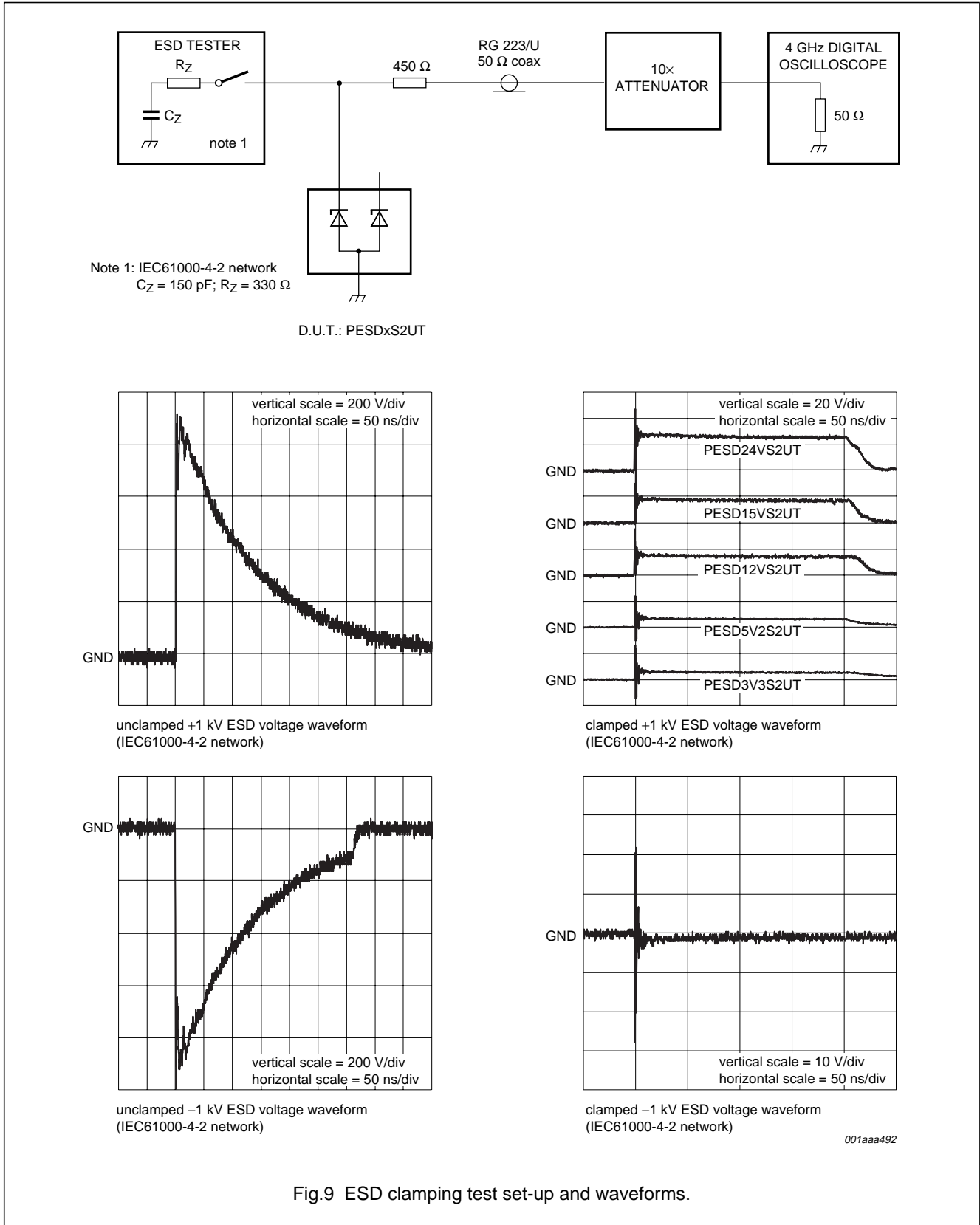

Fig.9 ESD clamping test set-up and waveforms.

Double ESD protection diodes in SOT23 package

PESDxS2UT series

APPLICATION INFORMATION

The PESDxS2UT series is designed for uni-directional protection for up to two lines against damage caused by ElectroStatic Discharge (ESD) and surge pulses. The PESDxS2UT series may be used on lines where the signal polarities are below ground. PESDxS2UT series provide a surge capability of up to 330 W (P_{pp}) per line for an 8/20 μ s waveform.

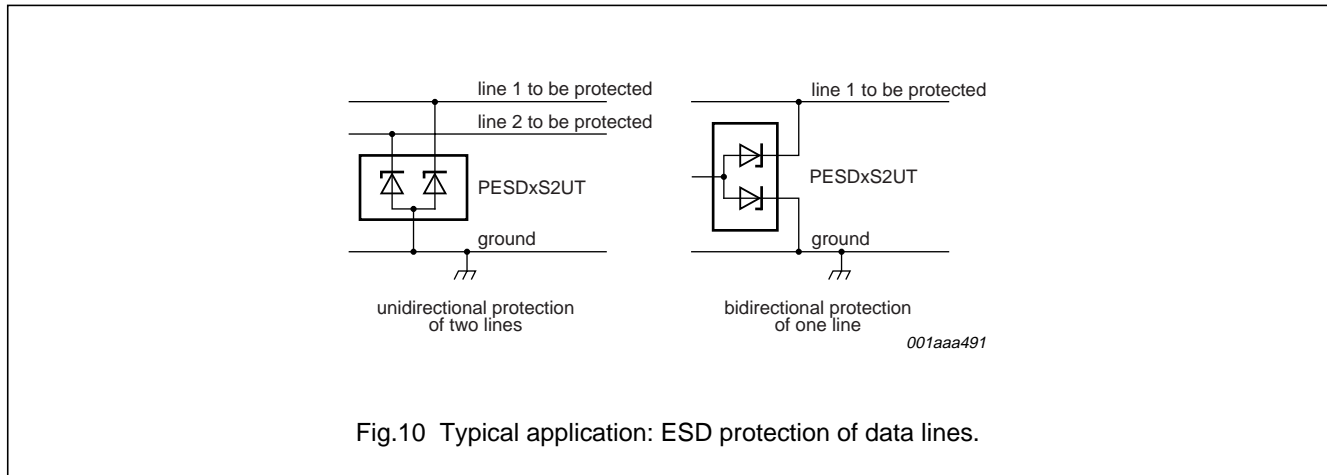

Circuit board layout and protection device placement

Circuit board layout is critical for the suppression of ESD, Electrical Fast Transient (EFT) and surge transients. The following guidelines are recommended:

- Place the PESDxS2UT as close as possible to the input terminal or connector.
- The path length between the PESDxS2UT and the protected line should be minimized.
- Keep parallel signal paths to a minimum.
- Avoid running protected conductors in parallel with unprotected conductors.
- Minimize all printed-circuit board conductive loops including power and ground loops.
- Minimize the length of transient return paths to ground.
- Avoid using shared return paths to a common ground point.
- Ground planes should be used whenever possible. For multilayer printed-circuit boards use ground vias.

Double ESD protection diodes
in SOT23 package

PESDxS2UT series

PACKAGE OUTLINE

Plastic surface mounted package; 3 leads

SOT23

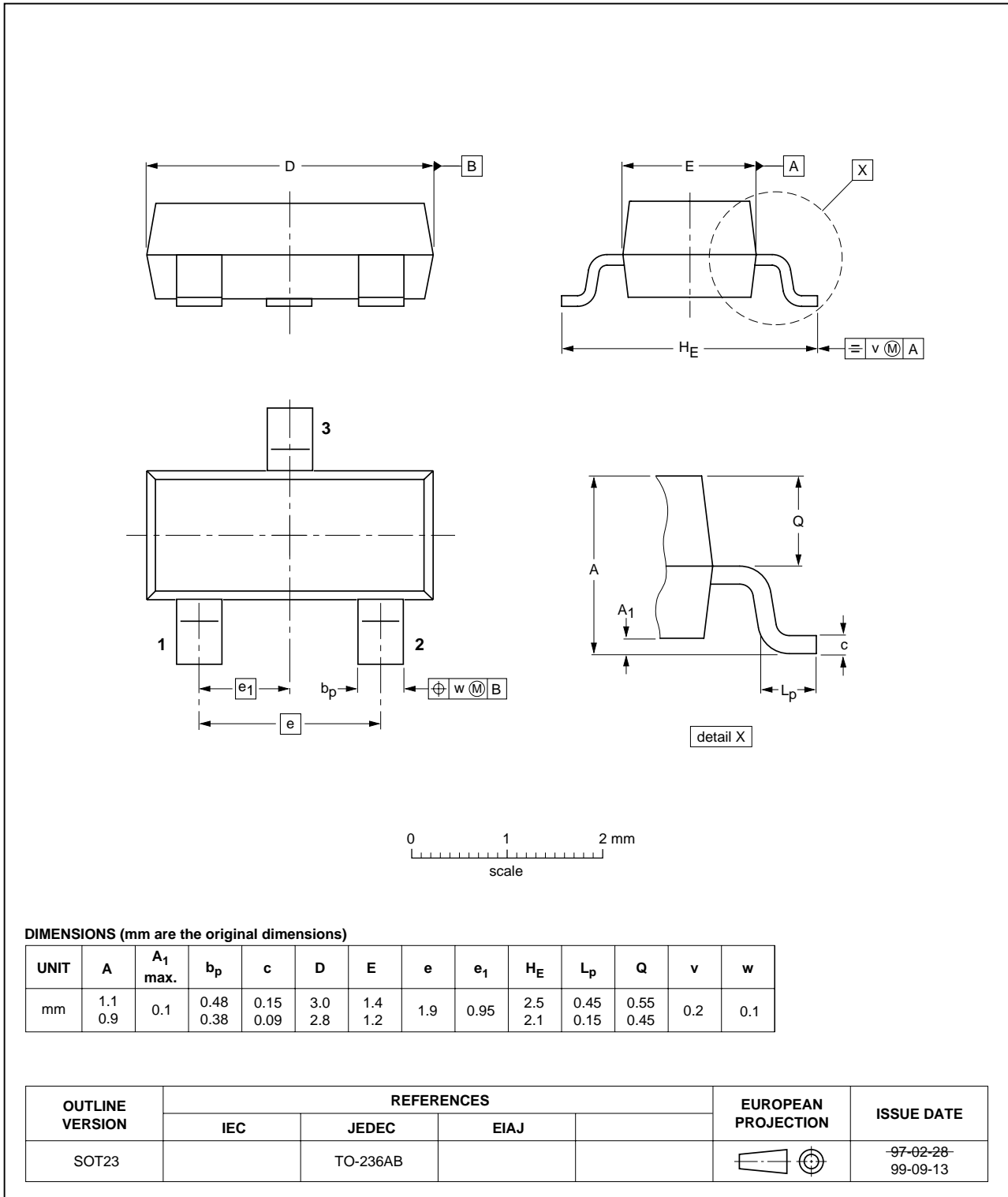

Double ESD protection diodes in SOT23 package

PESDxS2UT series

DATA SHEET STATUS

LEVEL	DATA SHEET STATUS ⁽¹⁾	PRODUCT STATUS ⁽²⁾⁽³⁾	DEFINITION
I	Objective data	Development	This data sheet contains data from the objective specification for product development. Philips Semiconductors reserves the right to change the specification in any manner without notice.
II	Preliminary data	Qualification	This data sheet contains data from the preliminary specification. Supplementary data will be published at a later date. Philips Semiconductors reserves the right to change the specification without notice, in order to improve the design and supply the best possible product.
III	Product data	Production	This data sheet contains data from the product specification. Philips Semiconductors reserves the right to make changes at any time in order to improve the design, manufacturing and supply. Relevant changes will be communicated via a Customer Product/Process Change Notification (CPCN).

Notes

1. Please consult the most recently issued data sheet before initiating or completing a design.
2. The product status of the device(s) described in this data sheet may have changed since this data sheet was published. The latest information is available on the Internet at URL <http://www.semiconductors.philips.com>.
3. For data sheets describing multiple type numbers, the highest-level product status determines the data sheet status.

DEFINITIONS

Short-form specification — The data in a short-form specification is extracted from a full data sheet with the same type number and title. For detailed information see the relevant data sheet or data handbook.

Limiting values definition — Limiting values given are in accordance with the Absolute Maximum Rating System (IEC 60134). Stress above one or more of the limiting values may cause permanent damage to the device. These are stress ratings only and operation of the device at these or at any other conditions above those given in the Characteristics sections of the specification is not implied. Exposure to limiting values for extended periods may affect device reliability.

Application information — Applications that are described herein for any of these products are for illustrative purposes only. Philips Semiconductors make no representation or warranty that such applications will be suitable for the specified use without further testing or modification.

DISCLAIMERS

Life support applications — These products are not designed for use in life support appliances, devices, or systems where malfunction of these products can reasonably be expected to result in personal injury. Philips Semiconductors customers using or selling these products for use in such applications do so at their own risk and agree to fully indemnify Philips Semiconductors for any damages resulting from such application.

Right to make changes — Philips Semiconductors reserves the right to make changes in the products - including circuits, standard cells, and/or software - described or contained herein in order to improve design and/or performance. When the product is in full production (status 'Production'), relevant changes will be communicated via a Customer Product/Process Change Notification (CPCN). Philips Semiconductors assumes no responsibility or liability for the use of any of these products, conveys no license or title under any patent, copyright, or mask work right to these products, and makes no representations or warranties that these products are free from patent, copyright, or mask work right infringement, unless otherwise specified.

Philips Semiconductors – a worldwide company

Contact information

For additional information please visit <http://www.semiconductors.philips.com>. Fax: +31 40 27 24825

For sales offices addresses send e-mail to: sales.addresses@www.semiconductors.philips.com.

© Koninklijke Philips Electronics N.V. 2004

SCA76

All rights are reserved. Reproduction in whole or in part is prohibited without the prior written consent of the copyright owner.

The information presented in this document does not form part of any quotation or contract, is believed to be accurate and reliable and may be changed without notice. No liability will be accepted by the publisher for any consequence of its use. Publication thereof does not convey nor imply any license under patent- or other industrial or intellectual property rights.

Printed in The Netherlands

R76/03/pp13

Date of release: 2004 Apr 15

Document order number: 9397 750 12823

Let's make things better.

**Philips
Semiconductors**



PHILIPS