

NUTS AND VOLTS

www.nutsvolts.com
October 2016

EVERYTHING FOR ELECTRONICS

How Does YOUR SCOPE Stack UP?

TURN YOUR RASPBERRY PI
into a media center

TRICKY TRAIN CONTROL
with an analog VOX

WHAT'S COMING IN WIRELESS
4G LTE vs 5G

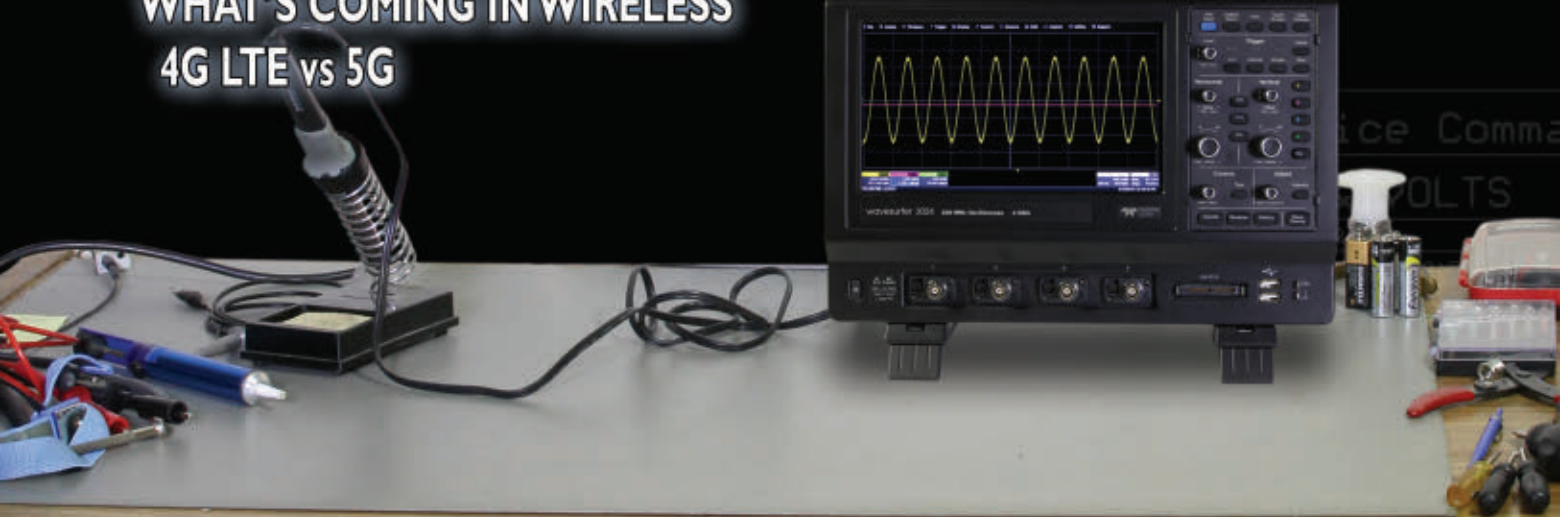
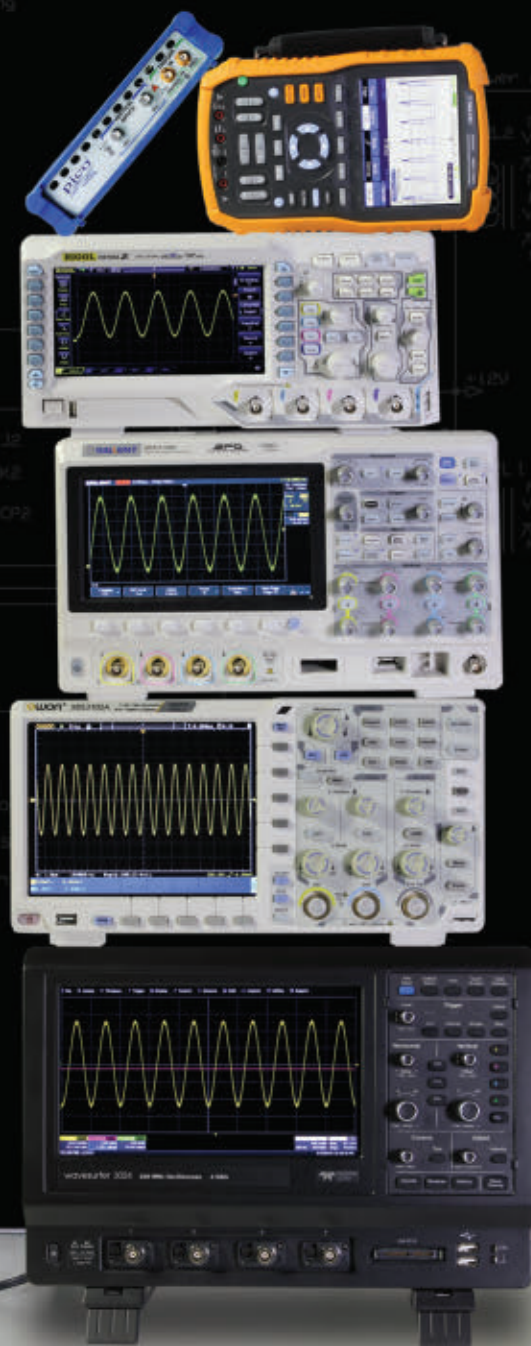

POWER PEAK[®] D7 400W

EQ-BID 12V/230V • PROFESSIONAL BALANCE CHARGER • DISCHARGER

AC/DC



Armed with two independent 200-watt output ports, producing up to 20 amps of charge current each, the Power Peak D7 brings power and convenience to your workshop and your hobby life. Its unique, revolutionary Multiplex-patented BID System allows assignment of a small, lightweight BID chip or key to store all relevant data for quick and easy battery setup. Experience the ultimate in battery charging convenience and intelligence.



FEATURES

- Input Power Source: 110–240 Volts AC / 11–30 Volts DC
- Total Maximum Output: 400 Watts
- Integrated Multiplex BID (Battery Identification) System
- Optional BID Chip and Keys Sold Separately
- Net Weight: 5.75 lbs (2.6kg)
- Dimensions: 10.6 x 7.9 x 3.3 in (270 x 200 x 85mm)

LiPo
1-7 Cells

LiFe
1-7 Cells

Lilon
1-7 Cells

NiMH
1-18 Cells

NiCd
1-18 Cells

PB
2-24 Volts

High Output Dual Charging System multi-charger X2 700

DC/DC



Featuring two 700-watt output ports for increased capacity and a whopping total 1400 watts of power, the X2-700 is the sophisticated charging choice for all high amperage batteries. Its "Charge Master" software (version 2) allows full PC control and the Synchronous Mode makes charging multiple similar batteries a snap.



FEATURES

- Input Power Source: 11–30 Volts DC
- Total Maximum Output: 1400 Watts
- "Charge Master" Software (version 2) for PC Interface
- Synchronous Mode for Setting Both Charge Channels thru Channel One
- Net Weight: 2.69 lbs (1.2kg)
- Dimensions: 7.9 x 5.5 x 2.2 in (200 x 140 x 55mm)

LiPo
2-8 Cells

LiHV
2-8 Cells

LiFe
2-8 Cells

Lilon
2-8 Cells

NiMH
1-20 Cells

NiCd
1-20 Cells

PB
2-24 Volts



NEW

PicoScope[®] 2000 Series PC OSCILLOSCOPES

LIKE A BENCHTOP OSCILLOSCOPE,
ONLY SMALLER AND BETTER!

- 2 channel, 4 channel and MSO models
- Up to 100 MHz bandwidth
- Up to 128 MS buffer memory
- Function generator and AWG
- Decode 16 serial protocols
- USB-connected and powered
- Windows, Linux and Mac software
- Prices from \$129 to \$1,235



REDEFINING THE EXPECTATION OF PC SCOPES

All models include full software and 5 year warranty. Software includes measurements, spectrum analyzer, advanced triggers, color persistence, serial decoding (15 protocols including 1-Wire, CAN, Ethernet, I²C, I²S, LIN, RS-232, SENT, SPI, USB 1.1), masks, math channels, all as standard, with FREE updates. Free Software Development Kit also available.



Learn more about this new range at www.picotech.com
or give us a call at 1-800-591-2796 to discuss your application

October 2016

20 Tricky Train Control with an Analog VOX

This unit lets you use voice control to manipulate your model train set. Plus, it's perfect to implement on other types of projects you'd like to command with your words.

■ By Randy Keenan

30 Build the Toilet Sentinel

Ever have trouble with your flapper not seating properly, allowing water to continually run? Well, consider that problem solved with this handy circuit.

■ By Larry Cicchinelli

35 Make Your Own Portable Media Center

With a few pieces of hardware and a Raspberry Pi, you can have a traveling entertainment system that fits in the palm of your hand.

■ By Craig A. Lindley

40 Choosing an Oscilloscope

Here are 15 tips that can make selecting the appropriate oscilloscope for your task at hand a lot easier.

■ By Alan Lowne

Columns

10 Q&A

Reader Questions Answered Here

Our new Q&A columnist, Kristen McIntyre takes on questions regarding how to build a gate and a case where battery polarity is not important, plus provides some needed help with a set of Archer ICs.

14 Open Communication

What's in the Works for Wireless?

Three technologies are forever changing wireless.

Wireless is so ubiquitous these days, that we take it for granted. However, there are even more things to expect for/from it in the future.

48 Near Space

Approaching the Final Frontier

My First Near Space Payload to Need an FAA Waiver

Don't know if we were setting a "record," but there were some special concerns that had to be met with this particular secret payload.



Page 35

Departments

- | | | | |
|----|---|----|-------------|
| 05 | DEVELOPING PERSPECTIVES
<i>Self-Monitoring Made Easy</i> | 46 | NV WEBSTORE |
| 06 | READER FEEDBACK | 50 | CLASSIFIEDS |
| 18 | NEW PRODUCTS | 62 | TECH FORUM |
| 19 | SHOWCASE | 65 | ELECTRO-NET |
| | | 65 | AD INDEX |

Subscription Information

Nuts & Volts — PO Box 15277
North Hollywood, CA 91615-9218
Call 877-525-2539 or go to www.nutsvolts.com
Subscribe · Gift · Renewal · Change of Info

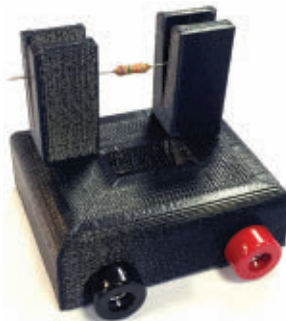

52 Practical 3D

Printing

Real World Uses for Electronics Experimenters

Resistor/Diode Tester

It occurred to me that the print we made last time for holding wires to make them easier to solder could be modified to become a resistor/diode

tester that would be just as handy to use.

56 The Design Cycle

Advanced Techniques for Design Engineers

Get Up and Running Quickly with BLE

Do you need to communicate with your smartphone using Bluetooth Low Energy (BLE) but feel that the learning curve is just too steep? This month, we will examine Microchip's new BM70 BLE radio module and all of the programming tools that come with it. We'll get you up and running quickly without any low-level BLE programming or expensive compilers and programmers.

Published Monthly By
T & L Publications, Inc.

430 Princeland Ct.
Corona, CA 92879-1300
(951) 371-8497

FAX **(951) 371-3052**

Webstore orders only **1-800-783-4624**

www.nutsvolts.com

Subscription Orders

Toll Free **1-877-525-2539**

Outside US **1-818-487-4545**

P.O. Box 15277

North Hollywood, CA 91615

FOUNDER

Jack Lemieux

PUBLISHER

Larry Lemieux

publisher@nutsvolts.com

ASSOCIATE PUBLISHER/ ADVERTISING SALES

Robin Lemieux

robin@nutsvolts.com

EDITOR

Bryan Bergeron

techedit-nutsvolts@yahoo.com

VP OF OPERATIONS

Vern Graner

vern@nutsvolts.com

CONTRIBUTING EDITORS

Kristen McIntyre

Fred Eady

Lou Frenzel

Paul Verhage

Chuck Hellebuyck

Alan Lowne

Craig Lindley

Randy Keenan

Larry Cicchinelli

CIRCULATION DEPARTMENT

subscribe@nutsvolts.com

SHOW COORDINATOR

Audrey Lemieux

WEBSTORE MARKETING COVER GRAPHICS

Brian Kirkpatrick

sales@nutsvolts.com

WEBSTORE MANAGER/ PRODUCTION

Sean Lemieux

sean@nutsvolts.com

ADMINISTRATIVE STAFF

Re Gandara

Copyright © 2016 by T & L Publications, Inc.

All Rights Reserved

All advertising is subject to publisher's approval. We are not responsible for mistakes, misprints, or typographical errors. *Nuts & Volts Magazine* assumes no responsibility for the availability or condition of advertised items or for the honesty of the advertiser. The publisher makes no claims for the legality of any item advertised in *Nuts & Volts*. This is the sole responsibility of the advertiser. Advertisers and their agencies agree to indemnify and protect the publisher from any and all claims, action, or expense arising from advertising placed in *Nuts & Volts*. Please send all editorial correspondence, UPS, overnight mail, and artwork to: **430 Princeland Court, Corona, CA 92879**.

DEVELOPING PERSPECTIVES

by
**Bryan
Bergeron,
Editor**

Self-Monitoring Made Easy

It's never been easier or more affordable to self-monitor everything from your heart rate to your body fat composition. Take the once lowly bathroom scale. My first smart scale — a Tanita capable of calculating percentage of body fat and water — cost several hundred dollars and took forever to compute statistics. Today, Tanita — as well as FitBit, Garmin, Omron, among others — offers smart scales that not only instantly compute body composition, but communicate the results via Bluetooth or Wi-Fi to a local computer or the Internet for archiving, plotting, and sharing.

The simple addition of wireless connectivity has totally transformed my experience of tracking body composition over time and adjusting my diet and exercise programs accordingly. Of course, there are the fitness bands, watches, and even old-school wireless chest strap sensors from Polar, Garmin, Fossil, FitBit, JawBone, Misfit, and others that track activity level and wirelessly communicate results to sites on the Internet for plotting and comparison.

The industry is in a bit of turmoil at the moment, with some familiar fitness band makers falling while other lesser known brands are rising. The result, for now, is great deals on the technology.

Unfortunately, not everyone has the luxury of leveraging self-monitoring technology with a goal of developing a six-pack or bettering their time in a marathon. Some of us must deal with hard realities of life, such as diabetes. Again, there are more affordable options than ever.

You can pick up a glucose monitoring kit at most local drug stores for \$20-\$30, including a supply

of blood lancets. Modestly more expensive monitors also upload the blood glucose levels to the Internet, where they can be plotted, trigger alarms to be answered by clinicians, and to provide a record for future reference.

If you haven't tried it, it's worth a few finger pricks to plot your blood glucose level over the course of a day. It can be life changing to see the familiar "sugar rush" followed by the "crash" with an improper diet. For example, you can test choices such as a plain white baked potato versus a premium chocolate ice cream cone (spoiler alert — the white potato will wreak havoc on your blood sugar level, while the ice cream will have relatively little effect because the fat content of the ice cream slows the absorption of sugar).

Lately, I've been building prototypes of self-monitoring smart clothes based on the LilyPad Arduino, with accelerometers and other sensors sewn into my shirts, pants, and shoes. The LilyPad disc is only a bit larger than a quarter and sews neatly onto any cloth or leather surface. The problem is the battery board.

While the LilyPad can be immersed in water with no ill effect, the battery board is susceptible to moisture. The key is to remove the battery before washing. Better yet, use spot cleaning or at least hand cleaning if you have to immerse the entire garment or shoe in water.

Next time you walk into a sporting goods or drug store, take note of the range of self-monitors available. Some may surprise you, and others may give you ideas on monitors of your own design. **NV**

READER FEEDBACK

Button Boo-Boo

In the Numitron article featured in the September issue of *Nuts & Volts*, the schematic section referred to in the "Buttons" portion of the piece had incorrect part labels. The corrected text and diagram are included here for your convenience. The problem originated from the fact that there are two buttons in the circuit, and when I reproduced the schematic excerpt I inadvertently copied the other button. The schematic excerpt therefore is correct; the text unfortunately referred to the other button. The red text is correct with the schematic shown in the magazine.

Bill van Dijk

Buttons

The clock is set using only two buttons with multiple functions to control 12/24 hour display selection, LED pattern selection, as well as setting the time. Buttons (or switches) are difficult things to read in high speed digital circuits since the mechanical parts in a switch or button actually bounce like a dropped ball; it takes a bit of time to stop settling in one state or the other when pushed. Debouncing can be done in software, but in this case, a hardware solution was used. The solution is based on the RC time required to charge/discharge a small capacitor.

When the button closes, the capacitor (C5) is discharged through a resistor (R20), allowing the bounce to settle before the voltage on the PIC input pin falls below the logic 0 level. When released, the capacitor is charged quickly through R17 and D3.

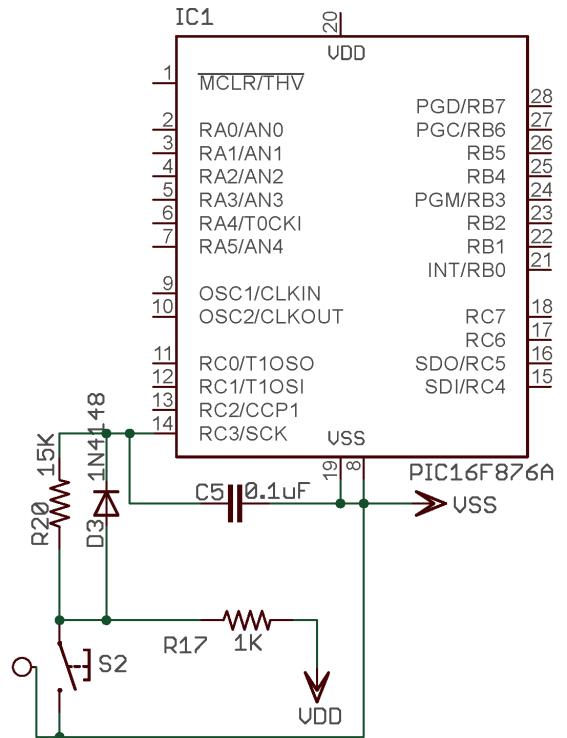

Words MIA

In Dane Weston's September 2016 article on simple hardware interfaces for the Mentor's Friend, the following text was inadvertently left out of Figure 5:

$$R1 = 2 * (Vdd - 3.9) \text{ K ohms}$$

$$R2 = 2 * Vdd \text{ K ohms}$$

Our apologies for any inconvenience.

NV Staff

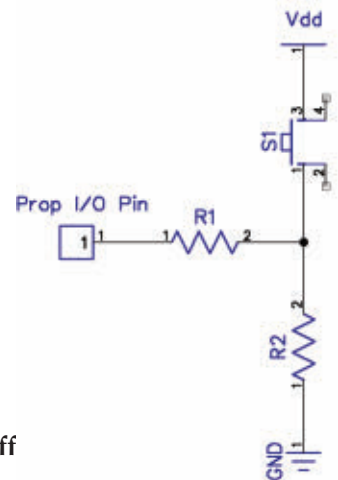

Graphic Incomplete

RE: In-Circuit Testing Techniques in the July 2016 issue: While this is an excellent article, there seems to be an error in the placement of the current meter. Since one side of the meter is connected to ground, the side that is connected to the resistors cannot be at ground potential. Therefore, the premise of an "effective open" for the 1.0K and 4.7K resistors is not correct. Should the current meter not be inserted on the hot side of the resistor network? For additional accuracy, the 1V power supply should probably be configured to control the actual voltage across the resistor network, i.e., it should be

The Easiest Way to Design Custom Front Panels & Enclosures

Free Front Panel Designer

You design it
to your specifications using our FREE CAD software, Front Panel Designer

We machine it
and ship to you a professionally finished product, no minimum quantity required

- Cost effective prototypes and production runs with no setup charges
- Powder-coated and anodized finishes in various colors
- Select from aluminum, acrylic or provide your own material
- Standard lead time in 5 days or express manufacturing in 3 or 1 days

FRONT PANEL EXPRESS

FrontPanelExpress.com

compensating for the current meter voltage drop.

K. Meyer

Unfortunately, there was an error in the print magazine where part of the image was cut off. Here is the complete graphic. Thanks for pointing this out.

NV Staff

On a Good Note ...

I enjoyed Bryan Bergeron's editorial on "Making History; Keep a Logbook." I would like to suggest that it is more likely that a logbook or engineering notebook will be kept if it is easy to maintain. I have been keeping an engineering notebook for many years on my projects in home automation, computers, and networking. I had been using a spiral notebook with cut and paste inserts (for datasheets), diagrams, and my poor penmanship.

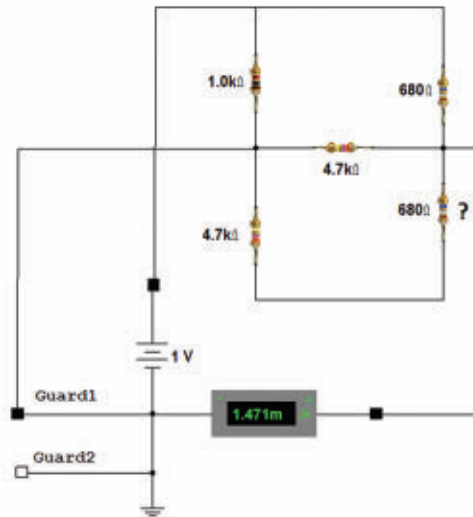

Recently, I have been using a new strategy: Microsoft OneNote. Here are some of the advantages I found after using it for several weeks:

1. It is free (my favorite price).
2. It encourages me to use the

keyboard for legibility.

3. It syncs to the cloud so I can read or edit the notebooks from my smartphone or iPad computer, no matter where I am.

4. I still draw a diagram on a piece of paper and then scan it in. The program has a drawing capability that can be used with a pen and tablet or mouse. However, I will stick with a pencil and paper since I am no artist.

5. The notebook has tabs, pages, and sub pages, and each can accept scans, online screen captures, photos, file attachments, web links, audio, video, spreadsheets, tables, and date/time stamping. It is very easy to stay organized.

6. I plan to print out a hard copy and backup a soft copy on a regular basis.

7. I have not accessed all the features yet, but it seems worth checking out. (Disclaimer: I have no

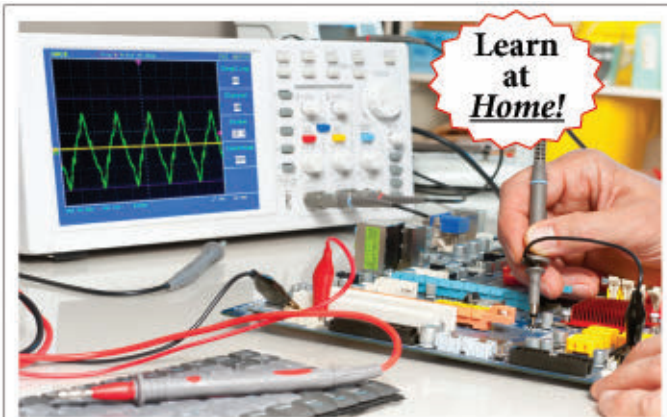

Learn
at
Home!

Electronics Courses

Cleveland Institute of Electronics

Train at home to be a professional *electronics* or *computer* technician! Learn with hands-on labs, instructor support, online exams, videos and instructor led chat rooms.

FREE course catalog www.cie-wc.edu or (800) 243-6446

- **NEW!** Robotics Automation Lab
- **NEW!** Computer Security Specialist
- Industrial Electronics with PLC
- Broadcast Engineering
- Electronics with FCC
- PC Troubleshooting
- Electronics Troubleshooting
- Networking

Visit www.cie-wc.edu and start today!

CIE: 1776 E. 17th St., Cleveland, OH 44114 • (800) 243-6446 • Registration 70-11-0002H



Best Value
prototype PCBs online
Turnkey Assembly available!

Serving over 10,000 PCB
Designers and Buyers
since 2003

Made in USA

www.PCBFabExpress.com

☎ 408-522-1500

Support3@pcbfabexpress.com

PoLabs

For more information or software download please visit 

www.poscope.com

PoKeys Connect, Control



- USB
- Ethernet
- Web server
- Modbus
- CNC (Mach3/4)
- IO
- PWM
- Encoders
- LCD
- Analog inputs
- Compact PLC

Stepper motor drivers Drive

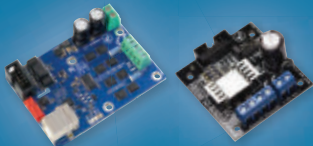

- up to 256 microsteps
- 50 V / 6 A
- USB configuration
- Isolated
- up to 32 microsteps
- 30 V / 2.5 A

PoScope Mega1+ PoScope Mega50 Measure



- up to 50MS/s
- resolution up to 12bit
- Lowest power consumption
- Smallest and lightest
- 7 in 1: Oscilloscope, FFT, X/Y, Recorder, Logic Analyzer, Protocol decoder, Signal generator

interest — financial or otherwise — in the product.)

Jack Olivieri

Thanks for the suggestion. I

haven't used OneNote, but certainly will give it a try.

I also hope many readers find your suggestion helpful as well.

Bryan Bergeron

Comments from the "Join the Conversation" question listed below that was featured in one of Nuts & Volts weekly content newsletters:

What was your favorite DIY project that had that "something special" packaging? Do you go the extra mile, or is it function over form for you?

Most of my stuff is out of sight of the public; data collector, a.k.a., box cars that watch equipment like hot water boilers. I use waterproof gray boxes from an electrical supply house. They also have waterproof box connectors. For the past 25 years, these have made the code inspector happy. When things go wrong, the box cars call home to speak with line item troubles like high amp draw or low water temp. It is fun to see the look on a customer's face when you show up because their equipment has called in a trouble.

Steven K. Ashcraft

My most recent case is for a Retro ELF (COSMAC ELF). It uses a good quality Hammond enclosure that is about double the price of the common box, and I dished out some money for laser etched and printed aluminum labels (like those used on the old ALTAIR 8800 computer). I don't often splurge to build a nice box; functionality and saving time is usually my priority, but when it comes to vintage computers, it's worth doing it nicely.

Dan Koellen

I've done front panels a number of different ways. Paint the panel blue, put white dry transfer, then spray it with clear lacquer. I have 20 year old equipment that still looks great. Also did paper panel layouts; cut the holes, then sprayed them with clear lacquer. Not as nice, but quick. Also did machine engraved panels; paint, then engrave, then clear. Also had silk-screened panels; they're really great looking but expensive.

Fred Bartholemew

Equipment is minimal so I use primitive methods. Aluminum panels painted white. Switches and LED functions are identified with vinyl

stick-on letters, then entire panels are covered in clear contact paper burnished down with the bubbles removed with a straight pin. This system has been used twice a month for over 10 years — several times for a solid week. They've been exposed to rain and drizzle and show little to no wear. Over 35 switches on the face. Internal terminal strips identified with ink jet printed labels and numbers held by Scotch tape completely covering cut-out items. Still holding after the mentioned 10 years.

G. Shaiffer

Because I have an electronics/machining background, I use lathes and milling machines extensively in my projects, from CNC drilling of PCBs to labels on engraving plastic. I'm now getting away from fabricating aluminum cases out of flat stock to plastic sheets cut to size and then machined to interlock with minimal screws and hardware.

Today, you can do all this with relatively cheap gantry CNC milling machines that can do a lot of really great work — much better than the new 3D printers which are getting better but just aren't good enough for my liking just yet.

Rob

Would you like to receive Nuts & Volts' weekly content newsletter? You have three ways to sign up:

- Visit us on Facebook and click on "Join My List."
- Using your cell phone, send "NVNEWSLETTER" as a text message to 22828.
- Visit the [Nuts & Volts FAQs](http://nutsvolts.com/faqs) to sign up at nutsvolts.com/faqs



wha.

Yep, the impossible just happened.

Celebrating
50 YEARS
CES | 1967-2017



Consumer
Technology
Association™

Jan. 5-8, 2017 | Las Vegas, NV

Register now at CES.tech

#CES2017

In this column, Kristen answers questions about all aspects of electronics, including computer hardware, software, circuits, electronic theory, troubleshooting, and anything else of interest to the hobbyist. Feel free to participate with your questions, comments, or suggestions. **Send all questions and comments to: Q&A@nutsvolts.com.**

- **How to Build a Gate**
- **Battery Polarity NOT Important**
- **Help with a Set of Archer Catalog #276-1783 ICs**

Hello to everyone who is reading the Q & A column today. This is my first one, so please bear with me as I settle in to try to answer your questions as best I can. I have to say that I'm honored by the trust the editors (and by proxy, the readers) have placed in me. I will do my best to earn that trust. Here in Silicon Valley where I live, I end up answering quite a few questions on the air on amateur radio. I hope to be able to do the same here. So, without further ado, let's dive in!

How to Build a Gate

Q I have been looking for a logic gate design for quite a while. I have read the book 'Code' and am very motivated to build some of the more complex logic circuits they explain. The foundation of these circuits is simple logic gates and I cannot find anything that is not overly complex. Some YouTube videos have gates that use capacitors, but they seem way more complex than necessary. Is there any way to build a quick and dirty gate out of two cheap transistors and the fewest possible resistors? I am looking for simple.

**Bert Brecht
Seattle, WA**

A That's a great question, Bert, and something I recently included in a talk I gave about transistor design, titled *The Mighty Transistor*. Unfortunately, simple designs with transistors are becoming a bit of a lost art. Let's see if we can revive that.

The simplest designs are typically called RTL, or Resistor Transistor Logic. A simple transistor in a saturated common emitter configuration can be used to create an inverter (see **Figure 1**). What we're basically doing in this NPN example is amplifying the input logic signal to the point where the transistor turns fully on when a logic 1 or high voltage is input, and turning it off completely when a logic 0 or low is input. In response, the collector falls when

it's on and rises when it's off.

It's not a perfect inverter for a few reasons. It's slow and it can't output much current when the output is high, but it often serves just fine. You can speed it up a bit by placing something like a few hundred picofarad capacitors across the base resistor. That will help push and pull the charge through the base, causing the transistor to change states more quickly. It's also possible to use a Field Effect Transistor (or FET) in this circuit. It might be faster, depending on the gate capacitance.

Now, how do we make a gate out of that? The simplest

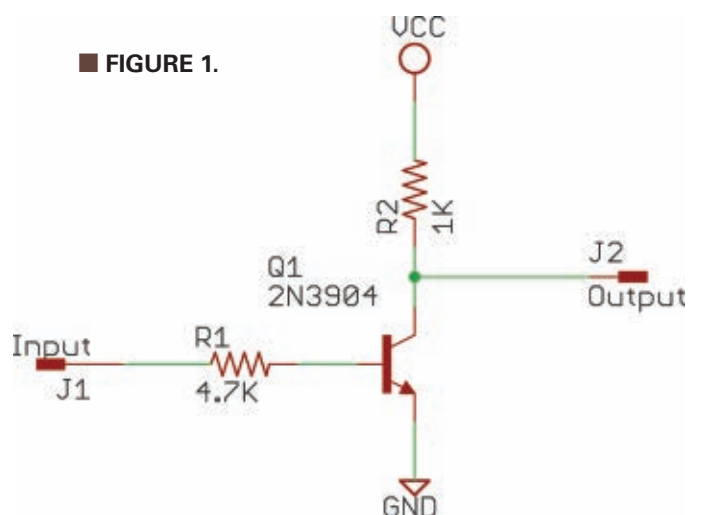

■ FIGURE 2.

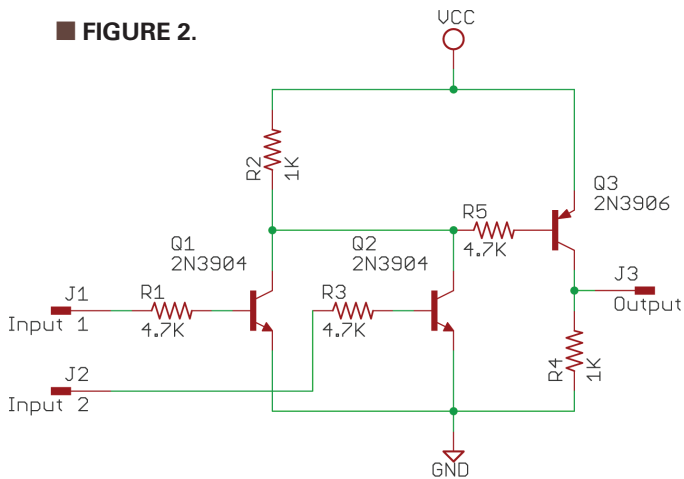

configuration is a NOR (or not OR) gate – an inverting OR gate. We do this by wire-OR-ing several inverters together. Since we rely on the collector pulling down for a low, but on a resistor for it to rise, we can just string inverters together while tying their collectors to a common node so that when any of them are turned on, the output will go low (see **Figure 2**). If we want to make that into an OR gate, we just put a single transistor inverter on the output; either a PNP or NPN will do.

With our OR gate out of the way, we need to make an AND gate. We can take advantage of something called De Morgan’s laws for logic transformation. If we invert the inputs of a NOR gate (like the one we already made), we can make an AND gate. You can see that simple circuit in **Figure 3**. It takes another transistor for each input to do the inversion. Similarly, you can invert the inputs to an AND gate and get a NOR gate, though that’s not what we’re doing here.

As for what transistors to use, any garden variety NPN or PNP will do just fine, as long as the current and voltage requirements are modest. I typically recommend two

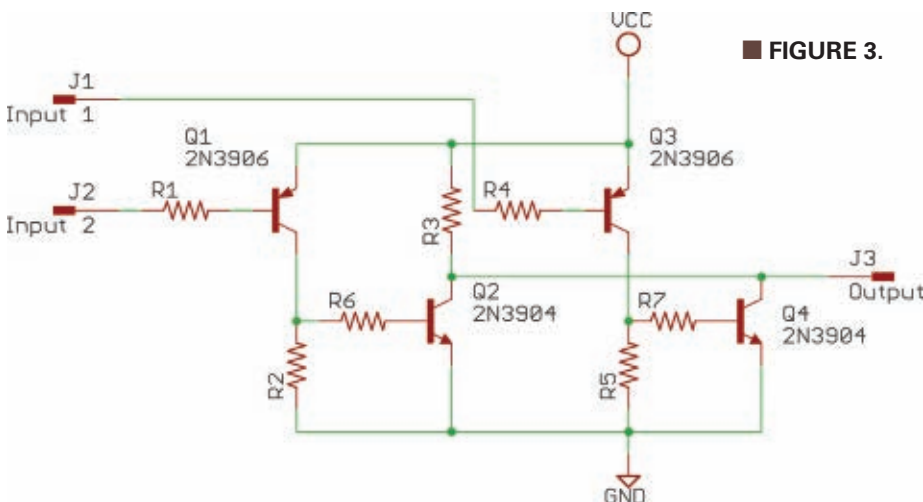

classics: 2N3904 NPN and 2N3906 PNP. They’re not that fast and not that capable, but often will get the job done. Note also that the resistor values are not very precise. I just chose ones that the transistor will be happy with, but you can change them to make the transistor work harder so that it will supply more current when pulling down, or decrease the collector resistor value to pull up harder.

If you’re interested in what can ultimately be done just with transistors for logic, James Newman built a computer he calls the Megaprocessor containing 40,000 transistors and 10,000 LEDs. Check it out at www.bbc.com/news/technology-36711989.

Battery Polarity NOT Important?

Q We have wireless microphones at our meeting place. The microphones don’t care which way the 9V battery is inserted. Do you have a circuit that shows how I can implement this in other projects?

Ted Mieske
via email

A That’s a pretty clever thing – making the microphone not care about the polarity of the battery. Fortunately, it’s not that hard to do, but at a small cost both monetarily and otherwise. Diodes are able to allow current to flow in one direction and not the other, within certain limits. We don’t care much about those limits for this particular application, as long as we use a reasonably good diode that can handle the necessary current.

When we want to rectify the AC voltage from a transformer, for example, we can use diodes to do this. **Figure 4** shows a very simple rectifier that will deliver one half of the sine wave coming out of the transformer which

■ FIGURE 3.

will be of just one polarity. That’s all well and good, but we are missing the chance to get the other half of that sine wave. There is potential energy there that could be used to power something.

In order to extract that, we use a more clever circuit – a full-wave bridge rectifier – that can take the voltage from the positive or negative parts of the sine wave and deliver them as a single DC voltage. It will still vary with the sine wave, but the polarity will always be the same. We can mostly fix that with a filter capacitor, but that’s not what we’re after for this question.

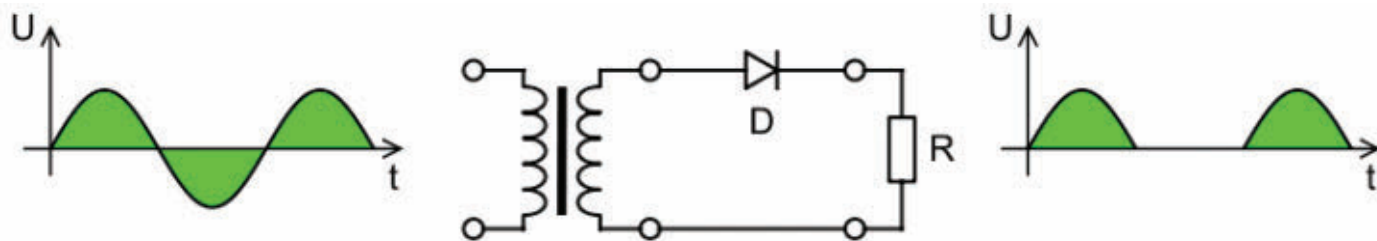

■ FIGURE 4.

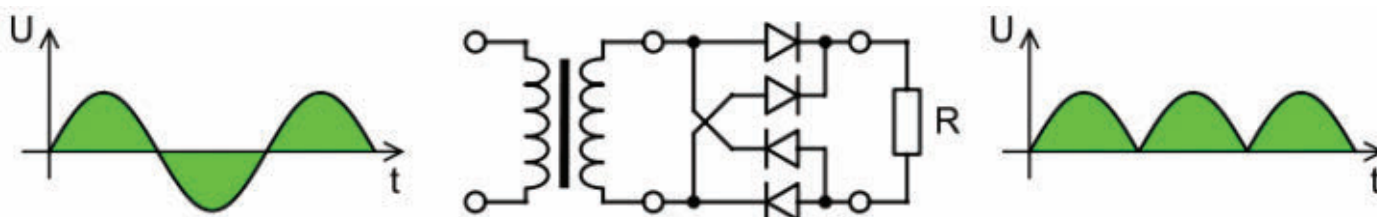

■ FIGURE 5.

If you follow the current flow through the diodes on each half cycle, you will see a path where no matter what the polarity of the transformer is, only one polarity ends up at the load (see **Figure 5**). Let's say that we remove that transformer and replace it with a battery. Connecting the battery one way is like the transformer giving us the positive half of the sine wave; connecting it the other way is like the negative half. What the load sees is always a consistent polarity.

In the case of your microphone, I'm guessing there is a full-wave bridge rectifier between the battery and the circuit that amplifies and transmits the signal. You can use this same technique to make other projects do the same thing. So, why don't we see this more often?

My best guess is that there are two reasons. The first is that a full-wave bridge rectifier is more expensive than a single reverse polarity protection diode; it's four instead of one of something. Sometimes there isn't even a single diode for protection, so if you put the battery in backwards the circuit is damaged. The second reason is voltage drop. Silicon diodes must have an approximately 0.6 volt drop across them before they will begin to conduct. For the full-wave bridge, that drop doubles to 1.2 volts. Even if you're using a 9V battery, that's a 13.3% drop, leaving you with 7.8V. For a pair of AAA batteries, almost one battery's worth of voltage is lost.

Not all circuits are designed to be able to function at lower voltages, but obviously this microphone can do it. Of course, you could build the bridge out of Schottky diodes and take advantage of their lower forward voltage drop, but they are more expensive.

Help with a Set of Archer Catalog #276-1783 ICs

Q I found a set of ICs when I moved into my new house. They are Archer catalog number 276-1783, and have the words: "VOICE SYNTHESIZER" on the package. The first chip (a 16-pin DIP) is a GI8351, with part number SPR016-117 and the bottom is stamped CC4. The second chip (a 28-pin DIP) is a GI8349, and on the bottom there is 32100-017. I have tried to look all over the Web to find out how to make it into a working voice synthesizer. If you can help out with this, I would be so happy.

**SSG E6 U.S. Army 1963 to 1972
Disabled Vet George Rowe**

A This was a difficult chipset to track down, but I think I've found the original part number for the set. There are several variations on these chips that were made by General Instruments and this is the SP0245-17 set, I believe. It looks like the first device (SPR016-117) is a 16K mask ROM (a Read Only Memory programmed by actually producing a semiconductor lithography mask with the bits embedded in it) containing pre-programmed words that can be connected to the 24-pin SP0256-AL2 voice synthesizer chip. There is a scan of the datasheet at www.speechchips.com/downloads/sp0256-17%20datasheet.pdf.

The second page of the datasheet shows two variations for connecting the devices, with the first being a stand-alone configuration, and the second making use of

the mask ROM. The pre-programmed vocabulary addresses are listed for the mask ROM on the last page. Even without the ROM, it should be possible using an embedded processor (like an Arduino or a Raspberry Pi) to program the synthesizer chip to output a series of allophones (phonemes, or basic sounds used in English) to form words that aren't programmed in the ROM.

There is more documentation on the Wikipedia page for this family of chips at https://en.wikipedia.org/wiki/General_Instrument_SP0256.

Looking around on the Web, it seems that several people have gotten these SP0256 devices to work with an Arduino. There is an Instructable that shows how to do it. This one doesn't use the ROM, but instead directly excites a series of allophones. You can see it at www.instructables.com/id/Arduino-Vintage-Speech-Chip/. There is some code there for the Arduino IDE (integrated development environment) that will get you started.

Looking at the library, it probably involved a lot of typing to get all of the allophone codes right. There is also an allophone address table document, as well as examples

of how to combine them to make common words. This is what you'll need to create first words and then sentences. Unfortunately, it appears as though this design doesn't include any amplification of the output audio. It won't be very loud without doing something, so you might consider an amplifier chip or building a simple one transistor class A amplifier to make it louder.

Another example of using this chip can be found at www.thefrankes.com/wp/?p=2490. It includes an amplifier for the audio output – at least in the prototype. There's a video there too, as well as a printed circuit board. The board doesn't appear to include the amplifier, but there's no schematic so it's not clear. If you watch and listen to the video, you'll see that this isn't really the state-of-the-art in speech synthesizers, but I think it would be a fun project getting it to work.

Image licenses: Figures 4 and 5 are licensed under Creative Commons 3.0 and were created by Walter Dvorak. They can be found at <https://en.wikipedia.org/wiki/Rectifier>.

Kristen McIntyre is currently a senior software engineer at Apple working on operating systems. She recently came back from being an entrepreneur in Japan. Previously, she was a researcher at Sun Microsystems Laboratories where she was researching robustness and emergent properties of large distributed computer systems.

Her career has spanned many diverse areas. She started in the early '80s designing high power linear amplifiers and then spent about five years in Japan architecting and designing precision analog test systems, as well as learning the Japanese language and culture. She speaks, reads, and writes Japanese fluently.

Upon returning to the states, Kristen joined Adobe Systems and became one of the architects of PostScript Level 2 and its RTOS underpinnings as well as the principal architect of AppleTalk networking for PostScript printers. In the early '90s, she became a consultant

and later founded an Internet service provider and network consulting firm. In 1999, Kristen decided to hang up her entrepreneur's hat and landed at Sun, tried the startup thing again only to land at Apple, where she's been since. Kristen holds a BS EECS from the Massachusetts Institute of Technology.

Kristen has been interested in radio since she was about five years old. When she was small, she built many radio kits including her favorite: the one tube radio kit. She started in amateur radio around 1979 while she was at MIT by getting her technician's license. She built a 2m repeater with an autopatch to use while on campus at MIT. Kristen is American Radio Relay League Technical Coordinator for the East Bay Section and is President of the Palo Alto Amateur Radio Association. She gives talks all around California and the Southwest on various technical topics. She is licensed with the amateur radio callsign K6WX in the United States, and J11ZZ in Japan.

What's in the Works for Wireless?

Three technologies are forever changing wireless.

How many wireless devices have you used today? There is no question that wireless technology dominates our lives these days. As for me, I have already used my smartphone to answer a text, talked on my home cordless phone, accessed the Internet via my Wi-Fi router, and opened and closed my garage door. My wife did all that plus she listened to satellite radio in the car and is talking on her smartphone as I write this. (No, we did not play Pokémon Go.) Wireless is so ubiquitous that we take it for granted, but there is even more to come. Here are some of the things to expect in the future.

5G Cellular

In case you haven't heard, the fifth generation of cellular telephone technology is under development. Currently, most of us are using the fourth-generation (4G) technology known as the Long Term Evolution (LTE). While this seems to be adequate for most of us, the continuous demand for higher speeds and greater subscriber capacity has been driving the development of the next-generation technology. The main driver of the development for 5G is video. More and more people are using their cell phones and tablets as TV sets for streaming video. This puts a very heavy load on the cellular networks. The forthcoming 5G systems will alleviate that problem.

Another forthcoming driver of 5G technology is the Internet of Things (IoT). The IoT is that concept for interconnecting practically all devices for the purpose of monitoring and controlling them by wireless networks and in some cases over the Internet. Common examples include adjusting home thermostats and monitoring video on your smartphone via the Web. Forecasts for IoT say that billions of devices will be connected, and many of those connections will also be through the cellular system. High speed 5G systems will help carry that expected load.

The fifth generation technology is being developed by an organization known as the Third-Generation Partnership Project (3GPP). It is expected to have a formal standard developed by mid 2019. The final standard will be sent to the International Telecommunications Union (ITU) in 2020 for formal adoption. It is expected that some cellular carriers will implement 5G cellular systems prior to the final availability of the standard. Some carriers are already conducting field trials to gain some early experience with the technology. This may give them a competitive edge when it comes time to deploy the full standard.

One of the key features of the new 5G standard is its use of millimeter wave spectrum. Most cell phone systems now use spectrum in the 800 MHz to 2 GHz range. Millimeter wave spectrum is generally regarded to be in the 30 to 300 GHz range. The Federal Communications Commission (FCC) recently allotted some new spectrum for 5G systems. These include segments of spectrum in the 28 GHz and 38 GHz range for licensed operation, and from the 64 to 71 GHz range for unlicensed operation. These higher frequencies provide more bandwidth to support high speed data transmission. Download speeds are expected to be in the 1 to 10 Gbps range.

New 5G systems will also use smaller cells. Instead of the large macro cells with antenna towers, 5G cells will be attached to lamp posts and the sides of buildings rather than on tall towers. There will also be more indoor

cells since the majority of cell phone calls are made from inside somewhere. Additional smaller cells will be needed to cover the same area because of the limited range of millimeter wave signals. The smaller cells will also be controlled by a network that is primarily software rather than hardware.

The high speed capabilities of 5G arise not only from wider bandwidth but also from the use of MIMO (multiple input multiple output). MIMO is the technique of using multiple transmitters, receivers, and antennas to divide up a high speed data stream into multiple signal streams. This provides not only higher speed, but also minimizes the effect of fading and multipath transmission common in the millimeter wave bands.

Antennas will also use adaptive beamforming. This technique automatically focuses the transmitted and received radiation into narrower streams to eliminate interference between cells and to improve transmission power.

5G technology will not be with us for several more years. However, considerable development is underway to make this happen. The availability of millimeter wave integrated circuits will certainly help this movement. One such device which is available now is shown in **Figure 1**. It is a complete 28 GHz transceiver that supports up to four transmit/receive antennas. Until 5G is available in 2020 and beyond, we will just have to be comfortable with the current 4G LTE systems, and that's not a bad thing at all.

LTE is Here Now

The 4G LTE systems that we now use have only been around since about 2008. It is a fully developed

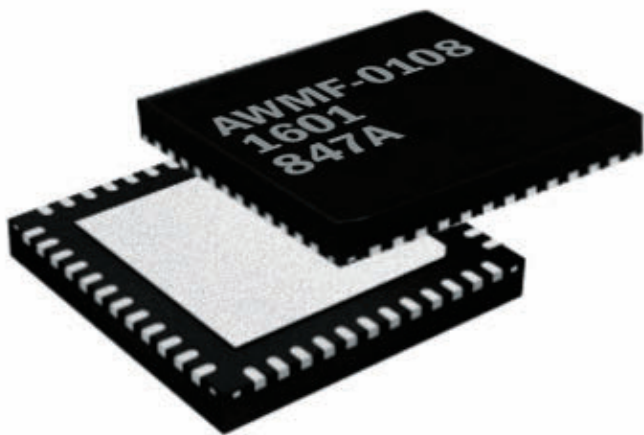

■ **FIGURE 1.** The Anokiwave IC is a complete 28 GHz Ka band millimeter wave band transceiver. It supports up to 4 x 4 MIMO and comes in a 6 x 6 mm package.

system that has been amazingly successful worldwide. Currently, there are 428 LTE networks in 155 countries, and that number continues to increase. Furthermore, upgrades and improvements are continually being made. LTE uses conventional cellular spectrum below 2.5 GHz. Using 20 MHz channels and 4 x 2 MIMO, it is possible to achieve download data rates of 150 Mb per second. The average download speed is considerably less than that by approximately a factor of 10, but this is more than adequate for most users. The actual download speed is a function of the capabilities of the cellular system, the number of users, as well as the range and environment of the user.

One of the most important improvements to LTE is the current rollout of LTE-Advanced. LTE-A provides for a feature called carrier aggregation. Carrier aggregation allows the cellular operators to combine up to five 20 MHz channels for up to 100 MHz of bandwidth. Combining that with 8 x 8 MIMO higher level QAM modulation can produce a maximum download speed of 1 Gbps. While not all systems will get this capability, most will adequately boost their download speeds to keep users happy with video streaming.

Another LTE upgrade going on right now is the addition of voice over LTE or VoLTE. This means that voice phone calls will be made digitally over LTE systems. Currently, most cellular carriers still widely use 2G and 3G cellular technology to carry voice traffic. VoLTE will improve voice quality and should lower overall costs. Eventually, most carriers will phase out older 2G and 3G technology anyway.

One interesting development with LTE is LTE Unlicensed and an equivalent technology called Licensed Assisted Access (LAA). Both of these are techniques that cellular operators can use to increase data rates. This is done by tapping into the unlicensed 5 GHz band spectrum. Where possible, LTE carriers can offload some high speed data to nearby Wi-Fi networks operating in the 5 GHz spectrum. While this can produce significant data rate increases to handle the video load, it can also cause interference to Wi-Fi signals in this unlicensed spectrum.

The latest Wi-Fi version 802.11ac uses 5 GHz spectrum exclusively. LTE-U and LAA technologies are not widely implemented yet, and the Wi-Fi Alliance is working with standards organizations and the carriers to ensure that data rate increases can occur but without interference to Wi-Fi users.

The Internet of Things Movement

The Internet of Things and an earlier technology known as machine-to-machine (M2M) communications are

THE LATEST IN NETWORKING AND WIRELESS TECHNOLOGIES

used to wirelessly monitor and control practically anything. Home applications of IoT such as controlling a thermostat or monitoring video with your smartphone were examples given earlier. However, there are many other things in



■ **FIGURE 2B.** The U-blox SARA-N2 module is an NB-IoT transceiver in a 16 x 26 mm package.

your home that can be monitored and controlled such as appliances, security systems, and lighting. This concept is especially useful in the industrial arena where it is useful to monitor and control machine tools, robots, and process equipment. Cities are implementing IoT to control street and traffic lights. Utilities are used to remotely reading electric, gas, and water meters. There are hundreds of other applications envisioned. Most forecasts project that 20 to 50 billion devices will be interconnected by 2020.

At the heart of these connections is the use of short-range wireless technologies to connect sensors and actuators to the Internet or some other network for monitor and control purposes. Most of the popular short-range wireless technologies have already been adopted for applications. These include Wi-Fi, Bluetooth, the 802.15.4 IEEE standard and its derivatives such as ZigBee, as well as Z-Wave. There doesn't seem to be any one standard at this point as the technology appears to be selected based on the application.

Typical range of operation is up to about 100 m. For longer range operation, a technology known as LoRa can be used. Other long range wireless technologies are the new Wi-Fi versions designated 802.11h or 802.11af, Sigfox, and Weightless. The fact that no one standard exists could

WORLD'S MOST VERSATILE
CIRCUIT BOARD HOLDERS

Model 324 Our Circuit Board Holders add versatility & precision to your DIY electronics project. Solder, assemble & organize with ease.

VISIT US ON  

MONTHLY CONTEST
Visit us on Facebook® to post a photo of your creative PanaVise project for a chance to win a PanaVise prize package.

PANAVISE®
Innovative Holding Solutions

7540 Colbert Drive • Reno • Nevada 89511 | (800) 759-7335 | www.PanaVise.com



 **AP CIRCUITS**
PCB Fabrication Since 1984

As low as...
\$9.95
each!

Two Boards
Two Layers
Two Masks
One Legend

Unmasked boards ship next day!

www.apcircuits.com

THE LATEST IN NETWORKING AND WIRELESS TECHNOLOGIES

lead to interoperability issues. As the technology develops, it is expected that some standards will emerge in particular for industrial and commercial applications.

One way to perform remote monitoring and control operations is to use the cellular network. Such systems are generally called M2M operations. Equipment manufacturers build in small cell phone modules that connect with the standard cellular telephone networks. In many cases, no Internet connection is needed. Most cellular carriers offer M2M services. Such operations have typically been expensive, and have been adopted only where they really produce some realizable benefit or return on investment.

Today, new LTE standards have been developed to provide a lower cost and lower power consumption way to use M2M. LTE is generally overkill for most remote monitoring and control applications as the high speed data rate simply is not needed. New LTE standards provide lower data rates and use less bandwidth. These include LTE CAT 1 that gives 20 Mbps in a 20 MHz channel; CAT 0 gives 1 Mbps in a 20 MHz channel. Even newer versions such as CAT M1 and CAT M2 deliver slower speeds and narrower bandwidths.

M1 produces 300 to 400 kbps in a standard LTE 1.4 MHz channel, while M2 (known as NB-IoT) gives 30 to 50 kbps in a standard 200 kHz channel. Several vendors are already offering complete modules for these low power/low data rate applications. **Figure 2** shows two of these.

With the advent of smartphone saturation, the cellular companies are looking for new streams of revenue. Smartphone growth is slowing, and the Internet of Things offers an opportunity for the carriers to add new subscribers in monitoring and control applications. LTE systems are more than adequate to handle new developments, but also look for 5G systems to handle a considerable amount of IoT and M2M traffic in the future.

Some IoT and M2M applications are with us now. However, massive growth is expected in the years to come. Some are questioning whether it is really necessary to monitor and control everything just because we can do it. Such monitoring and control activities will produce a massive amount of data that will go unused or unanalyzed. The wireless

systems themselves are relatively easy to develop and implement. The hard part will be storing, analyzing, and using the massive amount of data produced. That may be where the real IoT opportunity lies. **NV**



■ **FIGURE 2A.** Sequans Communications' Monarch module is a single .5 x 8.5 mm LTE CAT M1/M2 NB-IoT transceiver targeting IoT and M2M applications.



EARN MORE MONEY Get your dream job!

Be an FCC Licensed Wireless Technician!

Make up to \$100,000 a year and more with NO college degree

Get your "FCC Commercial License" with our proven Home-Study Course!

- No costly school. No classes to attend.
- Learn at home. Low cost!
- No experience needed!
- **MONEY BACK GUARANTEE:** You get your FCC License or money refunded!



Your "ticket" to 1,000's of high paying jobs in Radio-TV, Communications, Avionics, Radar, Maritime & more.

Call for **FREE** info: **800-877-8433** ext. 109

www.LicenseTraining.com

COMMAND PRODUCTIONS • FCC License Training
Industrial Center, 480 Gate Five Rd., PO Box 3000, Sausalito, CA 94966-3000

**Our
39th
Year**

NEW PRODUCTS

- HARDWARE
- SOFTWARE
- GADGETS
- TOOLS

LEAD SCREWS AND NUTS

ServoCity is now offering several new lead screw products. Their 8 mm lead screws offer an excellent way to turn rotational motion into linear motion. The 2 mm pitch offers a good trade-off between torque required to drive the screw and linear speed created. Each rotation of the lead screw will drive the mating nut precisely 8 mm. The OD of the lead screws is just under 8 mm to ensure proper fitment in an 8 mm ID bearing or clamp. These screws are commonly used in 3D printers, CNC routers, lift mechanisms, and automation projects, and are available in various lengths. Pricing on the lead screws goes from \$9.99 to \$39.99.

ServoCity's 8 mm lead screw barrel nut is intended to be used with their 8 mm lead screw. The threads are precisely cut to provide minimal backlash or side to side rock while retaining a low coefficient of friction between the bronze nut and the stainless lead screw. The .5" outside diameter works well with their clamping hubs which provides a solid way to attach Actobotics components to a drive system. The lead screws and nuts are commonly used on 3D printers, CNC machines, and lift mechanisms due to the high precision and strength. Cost of the 8 mm lead screw barrel nut is \$4.99.

ServoCity's 8 mm lead screw nut with a .770" pattern is intended to be used with their 8 mm lead screw. The threads are precisely cut to provide minimal backlash or side to side rock while retaining a low coefficient of friction between the bronze nut and the stainless lead screw. The .770" pattern provides a simple way to attach Actobotics components to a linear drive system, or if builders want a clamping solution to easily index the nut,



a 1" clamping hub around the outer diameter of the lead screw nut can be used. Pricing on the 8 mm lead screw nut with the 0.770" pattern is \$7.99.

For more information, contact:

ServoCity

www.servocity.com

JR GENIUS KIT BLINKY LIGHTS

The Junior Genius Kit from BusBoard Prototype Systems is a great introduction to electronics basics for somebody new to the hobby. It's ideal for anyone that hasn't built a circuit before, from grade 5 kids up to adults. Younger kids can do some or all of the activities with parental help, depending on ability. The 60 page

instruction manual helps students step through 10 activities, plus extra lessons and "Things to Try" experiments to learn about: how to use a breadboard; series and parallel circuits; wiring and connections; voltage and current; resistors, capacitors, and LEDs, and transistors and electronic switching. It leads the student step-by-step from a one LED circuit up to the blinking light circuit, explaining everything that's happening on the way.

All the required parts are included — even batteries. The kit uses a high quality breadboard and industry standard parts so that students get real world troubleshooting skills. They also get experience working with the same parts they will use on future projects. It builds more valuable experience than putting together simplified encapsulated parts aimed at very young children.

Membership in the Junior Genius



GUI MADE EASY

The arLCD 3.5" smart TFT touchscreen combines Arduino UNO with the ezLCD smart LCD.

earthlcd.com/nuts

NUTS AND VOLTS
EVERYTHING FOR ELECTRONICS

Welcome to the World of Electronics & Robotics!

This hands-on lab series has been specially crafted for those who are seeking knowledge in electronics and are considering a career in engineering, electronics, computers, or robotics. These comprehensive learning labs will give you a solid foundation in basic electronics concepts and components, and will help prepare you for a career in the electronics and technical industries. Complete details on all the Learning Labs are available in our website. Simply type "lab" into the search field at <http://store.nutsvolts.com>

target PCB. This socket can be used for hand test and characterization applications with the most stringent requirements.

Pricing for the SBT-BGA-7033 is \$491 (at qty 1) with reduced pricing available depending on quantity required.

For more information, contact:
Ironwood Electronics
www.ironwoodelectronics.com

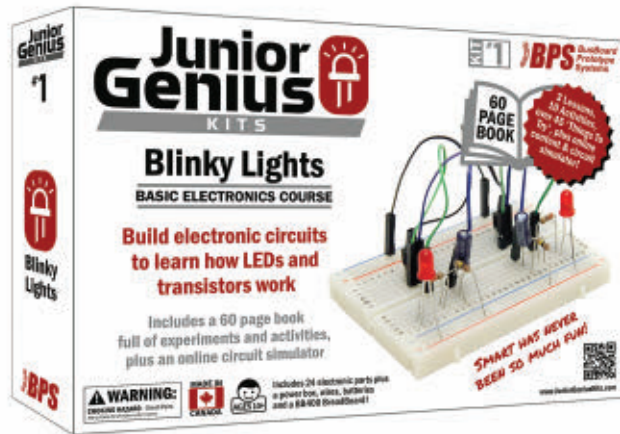

expanding them with breadboards and add-on circuitry.

Two expansion packs and a solder kit are available to continue exploring. Expansion Pack #1, "More LEDs" shows how to light up and switch more LEDs. Expansion Pack #2, the "10 LED IC Chaser" shows how to add a counter IC

to make an LED chaser, a traffic light, and a back and forth LED flasher (like Knight Rider's car). The Blinky Light solder kit provides the parts to solder the same circuit used in the kit to learn basic assembly skills.

Junior Genius Kit #1 - Blinky Lights sells for \$24.90. Expansion Pack #1 is \$7 and Expansion Pack #2 is \$12.

For more information, contact:
BusBoard Prototype Systems
www.JuniorGeniusKits.com

Club website is included with access to bonus content, plus an online circuit simulator which helps to visualize what is happening in the circuits. The book and online content provide more teaching material than is included with most kits. This is an "Intro to Electricity" course in a box.

The Junior Genius Kit is a good place to start to learn about electricity and connection basics before working with Arduinos or other programmable boards. A firm grasp of the essentials will help when troubleshooting projects and

SOCKET 98-PIN BGA WITH EXTREME TEMP SOCKET

Ironwood Electronics recently introduced a new BGA socket addressing high performance requirements for testing BGA devices: the SBT-BGA-7033. The contactor is a stamped spring pin with 31 gram actuation force per ball, and a cycle life of 125,000 insertions. The self-inductance of the contactor is 0.88 nH, insertion loss < 1 dB at 15.7 GHz, and capacitance 0.097 pF. The current capacity of each contactor is four amps at 30°C temperature rise. Socket temperature range is -55°C to +180°C. The socket also features a floating guide for precise ball to pin alignment.

The specific configuration of the package to be tested in the SBT-BGA-7033 is IDT's wireless power receiver

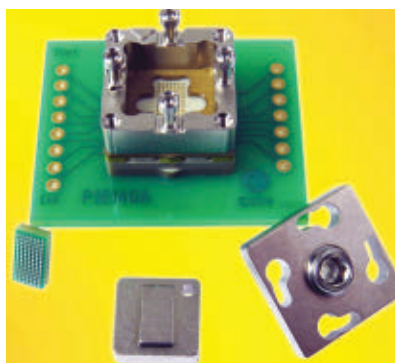

chip (BGA, 4x7.5 mm, 0.5 mm pitch, 98 position, 7x14 ball array) used to wirelessly charge the Galaxy S7. The socket is mounted using supplied hardware on the target printed circuit board (PCB) with no soldering. To use, place the BGA device into the socket base and swivel the socket lid on to the base using the shoulder screws. The socket uses a compression screw to apply downward pressure enabling the device to be interconnected to the

Tricky Train Control

WITH AN ANALOG VOX

By Randy Keenan

Post comments on this article and find any associated files and/or downloads at www.nutsvolts.com/magazine/article/October2016_Voice-Control-Analog-VOX.



■ **FIGURE 1.** The completed Train Voice Command unit. The rotary switch serves as an off-on switch; otherwise, it is not connected to anything and has absolutely no electronic function. Its purpose is amusement, and to mystify onlookers and make them believe that the train control can understand various and diverse languages.

This project enables you to command your model electric train using your voice: make it stop and go, and move forward and reverse. It is a simple sound-activated switch (VOX) plus a little logic circuitry. Nowadays, there are speech-recognition model train controls available (such as the one shown here: www.gamesontrack.co.uk/pages/webpage.asp?articleGuid=45776&menuGuid=23691&subMenuGuid=23697). However, this particular project is not as sophisticated, but can still be a lot of fun. A “command” can be a word, a part of a word, or possibly even two words as will be explained later. This project can also be used for voice control of other apparatus. I recommend this project for those who have some electronics construction experience.

How It Works

Basically, the circuit converts your spoken sounds into electrical pulses that are used to activate relays which control the electric power to the train (to the locomotive). The details should become clearer in the “Using the Train Voice Command” section near the end of this article. This project may not be suitable for elaborate train arrangements or for those using an electronic “E-unit,” using DCC® (Digital Command Control), using TMCC® (Lionel TrainMaster Command Control), or for train layout systems with accessories. The train control can be used in either of two modes, which I refer to as AC and DC:

AC mode – For locomotives (usually AC powered) that stop and go and change direction by means of an internal electromechanical or electronic sequencing system; for example, Lionel® (called E-unit), American Flyer®, and Marx locomotives. In this mode, the voice pulses activate a relay to interrupt the current to the train, causing the locomotive’s internal sequencing mechanism to advance one or more steps. The typical sequence is stop→forward→stop→reverse. (Stop is also sometimes called neutral.) Other sequences will be discussed later.

DC mode — For DC powered locomotives whose direction is determined by the current polarity. HO and N scale locomotives are typically of this type. In this mode, the voice pulses operate two relays: one that turns the current off and on, and another that controls the current polarity. I have designed the circuit so that the sequence is the same as mentioned above.

Check that your locomotive corresponds to one of these modes since there are exceptions. In both modes, the train power is electrically separate from the rest of the circuit.

A Condensed Back Story

Once upon a time, when vacuum tubes roamed the Earth and I was a lad, I enjoyed model railroading. I thought about controlling a train by speaking, and designed and built an electronic voice-operated control shown in **Figure 2** (not my best work). In response to voice “commands” (sounds), it performed an interruption of the train’s power circuit, so could only be used with locomotives having an internal sequencing mechanism (what I refer to as the AC type).

Unknown to me at the time, Louis Marx & Company had long before devised a voice-control system. It was a normally closed switch operated by air (voice) pressure (refer to US Patent 2221963, ca 1940, voice controlled toy train system). In contrast to my control, it was non-electronic.

A few years ago, I revived this idea for an interactive exhibit at a Maker Faire. In view of modern technology, I used solid-state electronics, and designed it to control either an AC or DC type of locomotive. My first version was designed and assembled under the pressure of a deadline, ruling out the opportunity to refine the circuit and construction, plus I used components that I had on hand. Since then, I have had time to work through a number of iterations to revise and simplify the design, with the result described in this article.

Before I get into the specifics of this circuit, I’d like to tell you about some of my previous decisions/choices along the way.

In early designs, in order to rectify the speech signal, I used a diode rather than optocouplers. This produced half-wave rectification of the audio signal. It also required level shifting for which I used PNP bipolar transistors. Thinking about ways to eliminate this complication, I hit upon the clever idea of using anti-parallel-input/parallel-output optocouplers to enable full-wave rectification of the signal. This simplified the level shifting, and allowed replacing the PNP transistors with the more common NPN type. Also,

■ **FIGURE 2. My first voice-operated switch for controlling model trains, based on two vacuum tubes. This only worked with locomotives having an internal sequencing mechanism. The power cord and the wires to the train power system are absent in these photos. Note the selenium rectifier on the underside, lower left.**

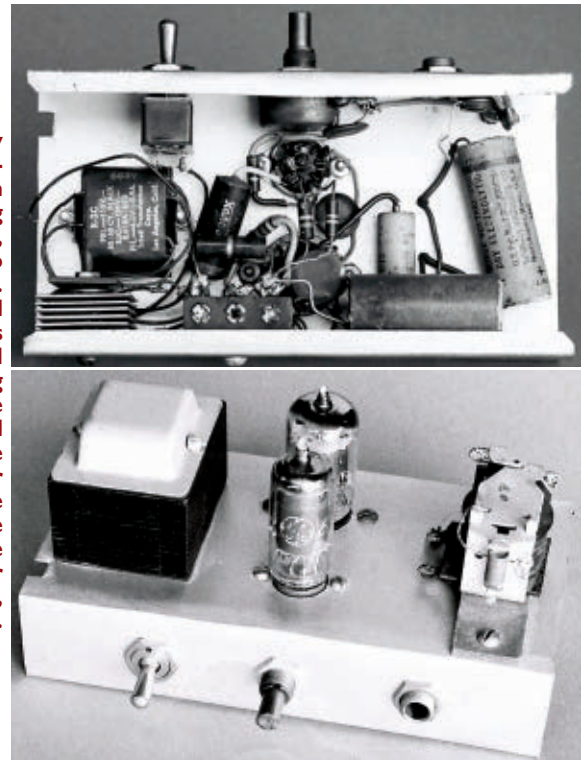

full-wave rectification meant that the energy of both the negative and positive parts of the speech signal would be used.

As in the ultimate design shown here, for the DC mode I chose flip-flops that triggered on a negative-going clock input so that the locomotive would not respond until the command was completed. I experimented with using a CD4000 series IC in place of the 74HC73 IC (U4), which would have possibly simplified the design, but I could not obtain consistent triggering.

Originally, I used separate relays for the AC (one relay) and the DC mode (two more relays), with a PNP bipolar transistor to drive each relay. I wrestled with the relay configuration a great deal to arrive at the present design. Its advantages include: (a) the AC and DC relay switching is combined and thus only two relays and two driver transistors are needed; (b) in AC mode, the locomotive current is only through RL1 which has greater current capacity; and (c) in DC mode, the locomotive current is switched by RL1 because RL2 is switched to the correct configuration before RL1 switches.

I added a capacitor-resistor combination for arc suppression at RL1’s contacts. These modifications reduce wear on the relays. Finally, I changed the relay driver transistors to MOSFETs because they require less gate current (essentially zero) compared to a bipolar’s base current.

I adjusted resistor and capacitor values to improve operation, and for DC mode added reset of the flip-flops at power-on. I even bought some new parts to replace the

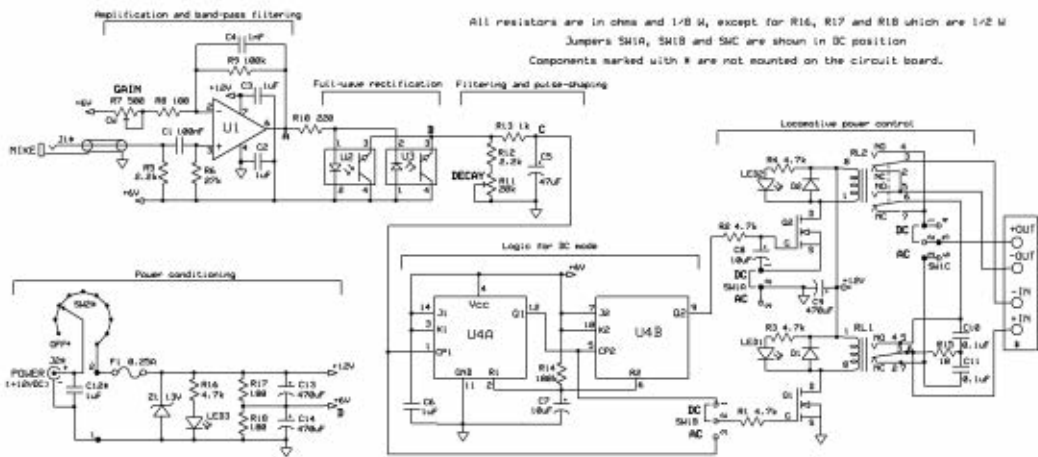

■ **FIGURE 3. Schematic of the Train Voice Command.**

arbitrary mystery ones from my recycle bins.

Why 12V? Several reasons: Twelve volt power converters and relays are common and I had them on hand. In regard to the circuit design, I needed to split the 12V for the op-amp and I wanted sufficient voltage to provide a margin above and below the output offset of the op-amp (possibly + or - a few tenths of a volt), plus the threshold voltage of the optocoupler input LEDs (about + and - 1.5 volts). The 6V was also suitable for the 74HC73 IC. I considered using an AC power converter rather than the DC converter, and obtaining the desired + and - voltages with diodes. However, this would require voltage regulator ICs or zener diodes, and wasted power to obtain + and - 6V.

Details of the Circuit

The schematic is shown in **Figure 3**. Electric power is provided by a power converter (wall wart) whose output is

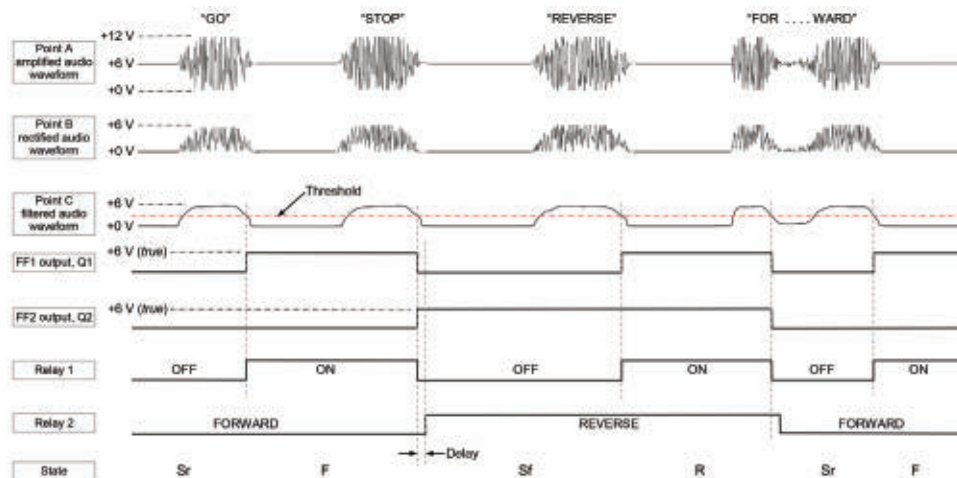

■ **FIGURE 4. Waveforms and logic timing for DC mode. Intervals between command sounds are greatly shortened in order to include everything in one figure. Delay in switching of RL2 (bottom four traces) is achieved by R2 and C8.**

+12V DC. Any converter can be used that provides +12V DC and a minimum of 200 mA (0.2A). Also, the polarity of the converter must be considered – the center pin must be positive. I like to include an LED (LED3) to indicate that power is present and of the correct polarity but this is optional. I have also included a zener diode (Z1, 13V) and fuse

(F1) to protect the circuit in case an inappropriate power converter is plugged in.

The zener can also guard against voltage spikes. R17 and R18 with C13 and C14 provide a voltage midway between +12V and 0V. The resulting +6V serves as an input reference voltage for the op-amp IC (U1), is a midpoint voltage for the LEDs in the optocouplers (U2 and U3), and provides +6V for the microphone and for the 74HC73 flip-flop IC (U4).

This project could also be powered by batteries, such as two sets of four AA cells (hopefully rechargeable). R17 and R18 could then be omitted.

The first requirement is to convert the command sounds into an electrical signal. This begins with the microphone (MIKE). An electret-capacitor type microphone is used; it requires a DC bias voltage which is supplied through R5. Capacitor C1 isolates this DC bias voltage from the op-amp input, and R6 with C1 attenuates the low frequencies. The op-amp (U1) amplifies the signal from the microphone several hundred times, but is also configured as a simple low-pass filter by the addition of the feedback capacitor C4, in combination with the feedback resistor R9. The resulting amplifier pass band is roughly 30 Hz to 3,000 Hz to eliminate non-essential and possibly interfering sounds.

For the following, refer to **Figure 4**. The signal output from the op-amp must be converted into a smooth pulse for switching. To do so, it is first rectified. This is done by means of a clever technique that uses both the positive-going and negative-going parts of the audio signal. The op-amp output is fed to two optocouplers (U2 and U3), with their LEDs connected anti-parallel.

Since the LED's light output has no polarity, it causes conduction in the paralleled output transistors whether the op-amp output (Point A) is + or - from the midpoint voltage of +6V. This yields full-wave rectification of the audio signal (Point B), which makes the next operation easier; namely, further filtering and shaping of the signal by C5, R12, R13, and adjustable resistor R11 to produce smooth pulses (at Point C) corresponding to the rectified sound "bursts" (at Point B). R11 adjusts the decay time of the pulse as described in the section, "Checkout and Adjustment."

The next operations are different depending on whether AC mode or DC mode is selected. Switching between AC and DC modes is by means of the three jumper switches SW1A, SW1B, and SW1C.

AC mode (sequential control): As described previously, this is for locomotives that have an internal sequencing mechanism. The circuitry for this mode is simpler: The voice-pulse signal is sent to relay RL1, connected as normally closed (NC) for the train's power, which is to be routed via the +IN and +OUT terminals (**Figure 5**). Each voice pulse interrupts the power and thus advances the locomotive's mechanism one step in its sequencing: forward→stop→reverse→stop etc.

DC mode (polarity control): For this type of locomotive, the direction is determined by the polarity of the applied power. Thus, we need to reverse the polarity of the power as well as turn it on and off. This is accomplished with some simple logic circuitry and both relays: one relay sets the electric current (RL2); and a second relay switches the power on and off (RL1).

The logic for the DC mode is provided by U4, which consists of two JK-type flip-flops (FFs) configured for toggle operation. Basically, they form a two-bit binary counter. The flip-flops operate as follows: If the J, K, and R pins are all inactivated (set high for the 74HC73), then every time a pulse is sent to the CP (clock) input, the outputs (Q = true and Q-bar = complement) change state. Here, we are only interested in the Q (true) output.

The voice pulses are sent to the CP input of FF1 (U4A). Its true output (Q1) is sent to the stop-go relay (RL1) so that the relay switches from off to on (and vice versa) each time a voice pulse is received. The true output of FF1 (Q1) is also sent to the CP input of FF2 (U4B), which thus switches for every second voice pulse. FF2's true output (Q2) is sent to relay RL2 which switches the polarity of the power to the train on every second voice pulse, thus cycling between forward or reverse after each stop as shown in **Figure 4**. R2 and C8 introduce a slight

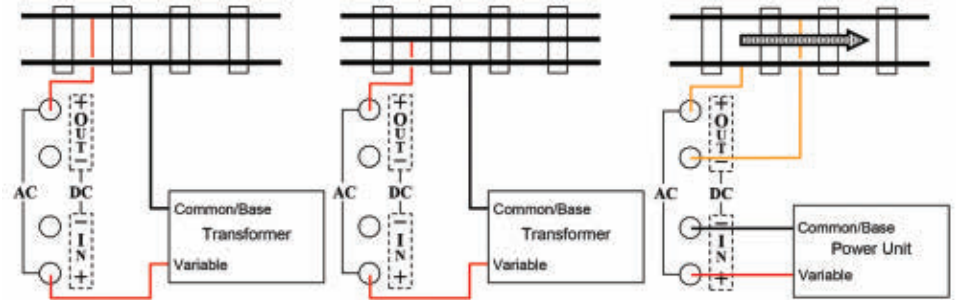

■ **FIGURE 5. Connecting to the train's electrical system: "AC" mode is on the left; "DC" mode is on the right, with the convention that the right-hand rail is positive facing forward. In DC mode, the power unit common switches between rails; if this is a problem, an alternative design is presented later.**

delay in the switching of RL2, so that it switches a fraction of a second after RL1. This means that the locomotive current is switched on or off only by RL1, which has greater current capacity and arc suppression; RL2 sets up the polarity but does not switch any current. (Another clever design feature.)

For DC mode, I wanted the circuit to power-up in a known condition; namely with the train stopped and ready to go forward. This requires that the FFs be reset at power-up. To do so, I added R14 and C7. Before power is applied, C7 is discharged. When power is applied, C7 is initially near 0V and the R (reset) inputs of U4 (pins 2 and 6) are low, which resets the Q1 and Q2 outputs to low. Both relays are un-energized. The NO contacts of RL1 are open so that no power reaches the locomotive, and RL2 is in the "forward" condition. After about a second, C7 charges to approximately +6V through R14 and the R inputs go high, enabling the flip-flops to operate in toggle mode. The next voice pulse will toggle U4A, which will energize RL1 and the locomotive will go forward (assuming that the train power connections are as indicated in **Figure 5** and that the connections to the track are appropriate).

Transistors Q1 and Q2 (MOSFETs; sorry if there is confusion between FF outputs Q1 and Q2 and transistors Q1 and Q2) boost the flip-flop outputs to drive the relays. Diodes D1 and D2 are connected in parallel with the relay coils to minimize voltage spikes when the relays de-energize. LEDs (LED1 and LED2) indicate when the corresponding relay is energized. LED1 and LED2 and R3 and R4 are optional, but I found them useful to check circuit operation and for practice.

To minimize parts, RL1 is used for both the AC and DC modes. The binding posts for connecting to the train's power circuit are also shared for both modes. Capacitors C11 for AC mode and C10 for DC mode with resistor R15 are connected across the contacts of RL1 to absorb the back voltage (back EMF) from the locomotive's motor when current is switched off, in order to reduce arcing at the contacts. As explained earlier, only RL1 switches current, so only RL1 needs the arcing suppression.

State	Train is ...
F	Moving forward
Sf	Stopped
R	Moving in reverse
Sr	Stopped
F	Moving forward
Sf	Stopped
R	Moving in reverse
---	Etc.

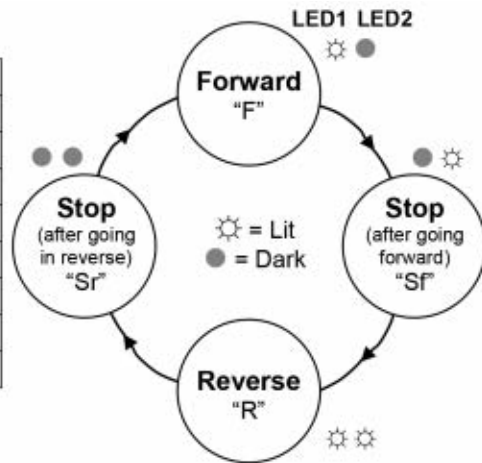

■ **FIGURE 6. Sequence of “states” that the circuit follows. For AC locomotives, this sequence is internal; for DC locomotives, the sequence is brought about by the flip-flops in U4 and relays RL1 and RL2. The lighting of LED1 and LED2 is indicated for DC mode.**

The Command Sequence

Figure 6 illustrates the sequence that the circuit follows. The table on the left lists the four situations or “states” that the train can be in: F = train moving forward; Sf = train stopped after moving forward; R = train moving in reverse; and Sr = train stopped after moving in reverse. There are two stopped states, depending on which direction the train was moving before being stopped. This is important because the next command (voice pulse) will cause the train to move forward or reverse depending on

which stopped state it is in. For consistency, the circuit follows the same sequence for both the AC and DC modes (stop→forward→stop→reverse), even though three states would be enough for DC.

Another way to illustrate the sequence is shown by the diagram on the right. Each situation or “state” is indicated by a circle, and possible changes from one state to another are indicated by lines connecting the circles with arrows that show the allowed direction of the changes. Each command (voice) pulse will cause one advance in the state clockwise, as indicated by the arrows.

For example, if the train is in Sr and it receives a command pulse, it will then move forward (advancing one state to F),

whereas if it is in Sf and receives one pulse, it will move in reverse (advancing one state to R). If the train is moving, one pulse will halt it (advancing one state to either Sr or Sf).

Now suppose that the train is moving forward and you want it to move in reverse. You will need two command pulses to move it two states (from F to Sf to R). Or, if it is moving forward and you want to stop it and have it ready to move forward again, three pulses will be needed (three state changes from F to Sf to R to Sr). More explanation is given in the last section, “Using the Train Voice Command.”

A diagram such as this is called a state diagram. This is a very simple example. A state diagram indicates the possible states of a system (shown here as circles) and the possible transitions between those states (shown here by arrows); furthermore, only one state is possible at a time. In our case, the system is an electronic / electrical / mechanical system.

Table 1 — Operation and troubleshooting for DC mode.				
Pulse = FF1* input	FF1 Q1 output = RL1	FF2 Q2 output = RL2	Train	LED1, 2**
Initial (power-up)	Low (0V) = RL1 not energized = off	Low, RL2 not energized (direct, + to + and - to -)	Stopped (Sr)	●●
1	High (+6V) = RL1 energized = on	“	Forward (F)	☀●
2	Low = RL1 not energized = off	High, RL2 energized after delay (reversed, + to - and - to +)	Stopped (Sf)	●☀
3	High = RL1 energized = on	High, RL2 energized (reversed, + to - and - to +)	Reverse (R)	☀☀
4	Low = RL1 not energized = off	Low, RL2 de-energized after delay (direct, + to + and - to -)	Stopped (Sr)	●●
5 (same as 1)	High = RL1 energized = on	Low, RL2 not energized (direct, + to + and - to -)	Forward (F)	☀●
Etc.				
*FF: flip-flop, in IC U4 (see Figure 3); Q1, Q2 low = 0V (false), high = +6V (true)				
**☀ = lit, ● = dark.				

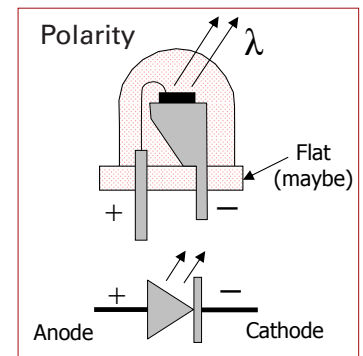

(Information on state diagrams can be found on the Internet.)

Table 1 gives the circuit conditions for the sequence in DC mode.

If your locomotive uses a three-state sequence (such as stop-forward-reverse) which is possible with AC type locomotives, simply change the sequence of commands. If your particular locomotive sequence has only forward and reverse (no neutral), use DC mode and the connection as shown in **Figure 5** on the right.

Construction

Many of the parts (or ones that can be substituted) are probably in your “recycle” bins.

Here is your opportunity to try some experimentation. Be sure to use a jack (J2) that matches the wall wart output plug. These plug and jack combinations can be confusing because of the different diameters of the center pin. Also, ensure that the polarity is correct. The center pin of the wall wart must be +. I also recommend checking its output voltage, preferably with a scope as well as with a voltmeter. I have found faulty units that produce higher than indicated output voltage or excessive “hash.”

As you can see from the **Parts List**, many components may be varied, including R17 and R18 (but they must have equal resistance); C13 and C14 may be larger than 470 µF. Other parts can be substituted. Q1 and Q2 can be 2N7000 MOSFETs, but I prefer the higher current ZVN4206ASTZ. Also, nearly any NPN bipolar transistor should work in place of a MOSFET if it has a reasonable current gain (at least 50) and about 100 mA current capability. (I tend to

Wire Hint

I like to use wires of different colors to keep track easier. However, buying spools of many colors gets expensive and unnecessary if you only use a few feet per project. Instead, I remove the outer jacket and shield from an old computer cable and use the wires inside.

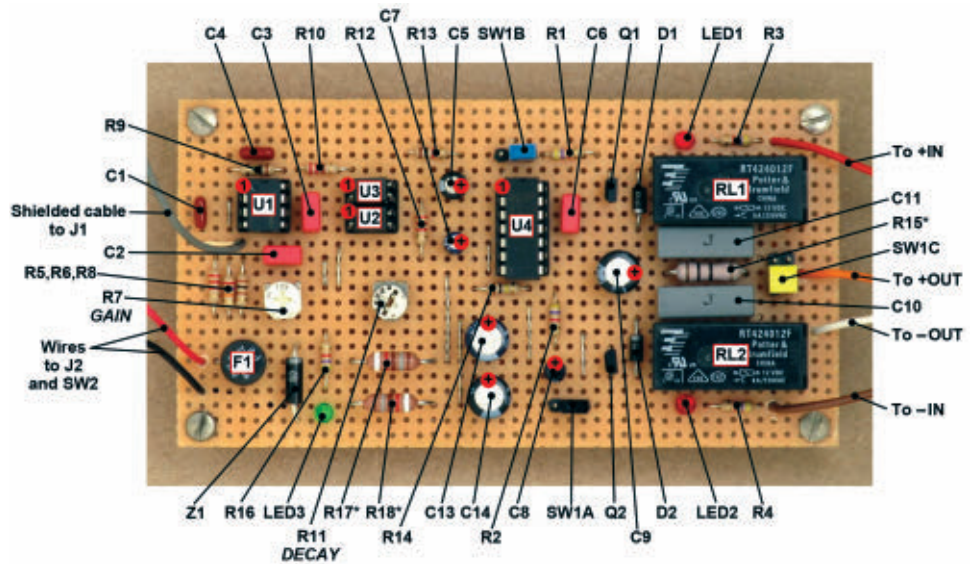
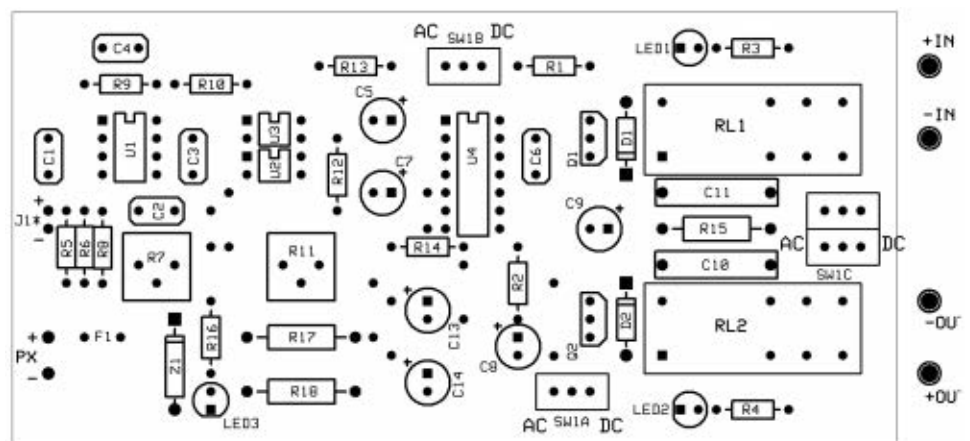

FIGURE 7. The assembled wiring board with part callouts. Note that R15, R17, and R18 are spaced away from the wiring board. I used sockets for all the ICs. I used the same model DPDT relay for RL1 as for RL2 and paralleled the contacts on RL1. In the **Parts List**, an SPDT relay is specified.

use larger transistors to not stress them.)

If you use bipolars, the delay components R2 and C8 may need adjustment. D1 and D2 can be any small rectifier diodes; I used 1N4937 because they were in my recycle bin. Be sure of their orientation. Otherwise, Q1 and Q2 could be damaged. I tried many different electret-condenser mikes and all worked (**Parts List**, Note 1). Observe the mike polarity. Also, many different optocouplers worked (**Parts List**, Note 4).

The component layout and assembled wiring board are shown in **Figure 7**. I made a printed circuit board (PCB) layout (**Figure 8**) as a guide for parts placement and to check the wiring. However, because I was making only one assembly I did not make a PCB, but wired everything



The following components are not mounted on the circuit board:
J1, J2, C9, SW2, and the four IN and OUT binding posts.

FIGURE 8. A possible PCB design. I did not use a printed circuit board, but hand-wired everything (Figure 9). Even though I did not use a PCB, creating this layout was helpful in arranging the components and wiring.

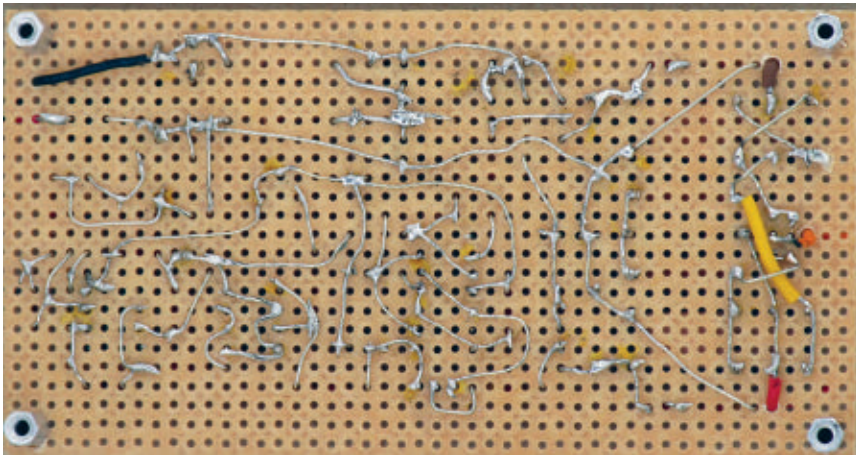

■ **FIGURE 9.** Underside of the wiring board. The hand wiring approximately follows the PCB layout of Figure 8. For the bottom side traces in the PCB layout, the wires are threaded through to the top side of the perf board (see Figure 7).

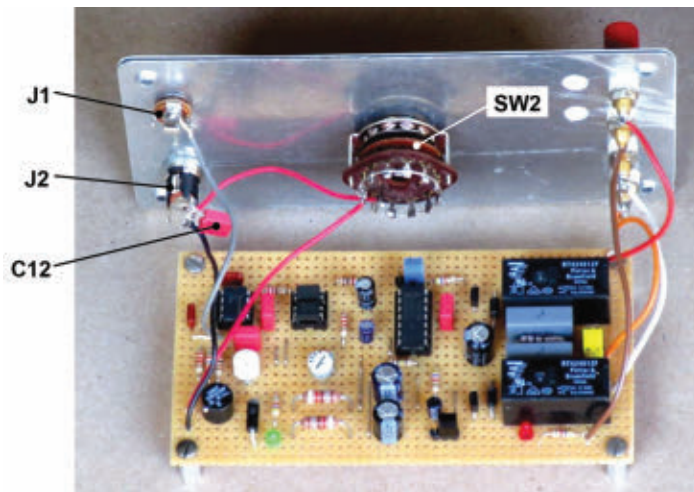

■ **FIGURE 10.** Wiring board and panel connected. Note that C12 is mounted directly at the power connector. (Extra holes in the panel are from previous designs.)

by hand as shown in Figure 9. If you use a PCB, I recommend augmenting the traces on the switching contacts of the relays with wires because they must handle the relatively high current for the locomotive. The relay pins are numbered in the same manner as IC pins; in other words, clockwise when viewed from the bottom.

Construction is not critical, although it is best to keep wires short — especially those between the bypass capacitors (C2, C3) and the op-amp (U1); between the bypass capacitor (C6) and the flip-flop IC (U4); and between C9 and the driver transistors (Q1, Q2) and relay coils. Connect C12 directly at the terminals of J2 as shown in Figure 10. Mount the 1/2W resistors R17 and R18 so that they are spaced away from the wiring board by perhaps 1/4 inch since they are dissipating about 1/4W each. Likewise, mount R15 away from the board. I used a

single eight-pin IC socket for both U2 and U3. In place of U2 and U3, you may use a single four-pin optocoupler that has anti-parallel LEDs, such as the FOD814A (as in Figure 7). Handle the MOSFETs carefully since the gates are easy to damage.

To create the front panel shown back in Figure 1, I used basic drawing software and printed the result onto cardstock. I glued the cardstock to the front panel of the enclosure (after the holes were drilled in the panel for J1, J2, SW2, and the four binding posts), and covered the cardstock with a clear plastic sheet (for example, Swingline GBC SelfSeal Laminating Sheets #3747308 [non-machine]). After applying the cardstock and plastic sheets, I trimmed them and cut the holes through using a fine knife. I found that the front panel could be snapped into the

enclosure and did not require screws.

Checkout and Adjustment

Adjustment and troubleshooting are easier with an oscilloscope. Before inserting any ICs, apply power; LED3 should be lit, and LED1 and LED2 should be dark. Check that the following voltages are correct and have the right polarity (refer back to Figure 3; all voltages are referred to ground = 0V):

- At the center contact of J2: +12V. At Point D: +6V. (R17 and R18 will become warm during operation; this is normal, so watch your fingers.)
- IC U1: Pin 7 = +12V; pin 4 = 0V
- ICs U2 and U3 (if using an eight-pin socket and two optocouplers): pins 1, 4, 6, 8 = +6V
- IC U4, pins 3, 4, 7, 10, 14 = +6V; pin 11 = 0V. The voltages at pins 2 and 6 will depend on the sensitivity of your meter (W/V), but should initially be close to +6V and then may decrease as C7 discharges through your meter.
- At the microphone center contact: close to +6V; this will also depend on the sensitivity of your meter.

If the voltages check out, turn the power off, connect the microphone, and adjust the op-amp (U1) gain to minimum (R7 to maximum resistance, fully CCW; if R7 is connected according to the PCB layout in Figure 8). Insert the op-amp U1 (check the orientation), turn the power on, and check the voltage at the op-amp output. Measure between pin 6 of U1 (Point A) and the midpoint voltage (Point D). The voltage should be within $\pm 0.3V$. If not, try a different op-amp for U1 (see Note 3).

ITEM	QTY	SCHEMATIC REFERENCE (FIGURE 3)	PARAMETERS	NOTES, PART NUMBERS, AND VENDOR CATALOG NUMBERS*
Power converter	1	---	Output 12V DC, 0.2A minimum	Jameco 252795 or try your local thrift store
Power jack	1	J2	Panel mount, to match above	For Jameco 252795 (2.1 mm x 5.5 mm) use Jameco 151555
Microphone	1	Mike	Electret capacitor, -60 to -40 dB output (-40 dB preferred), bias range includes 6V For microphone	Note 1
Shielded wire (or twisted wires)	As req'd	---	---	†These parts are not needed for an AC-only version.
Plug for microphone	1	(P1)	Mini phone plug, but another type can be substituted	---
Jack for microphone	1	J1	Panel mount, to match P1	---
Capacitor, polymer	1	C1	100 nF (104)**	---
Capacitor, polymer	4	C2, C3, C6†, C12	1 μF (105)**	---
Capacitor, polymer	1	C4	1 nF (102)**	---
Capacitor, aluminum electrolytic	1	C5	47 μF, 16V	---
Capacitor, aluminum electrolytic	2	C7, C8	10 μF, 16V	---
Capacitor, aluminum electrolytic	3	C9, C13, C14	470 μF, 16V	Could use 680 μF or 1,000 μF
Capacitor, polymer, suppression	2	C10, C11	0.1 μF or 0.068 μF, 310V AC	Vishay/Roederstein F1772SX241031KFIB0, Mouser 75 F1772SX241031KFIB, Vishay/Roederstein F1772SX236831KFIB0, Mouser 75-F1772SX236831KFIB
Resistor	2	R1, R2†	(4.7 kΩ)	Note 2
Resistor	3	R3, R4†, R16	4.7 kΩ	Optional with LED1, LED2, LED3
Resistor	2	R5, R12	2.2 kΩ	---
Resistor	1	R6	27 kΩ	---
Trimmer potentiometer (GAIN)	1	R7	500Ω	---
Resistor	1	R8	100Ω	---
Resistor	2	R9, R14†	100 kΩ	---
Resistor	1	R10	220Ω	---
Trimmer potentiometer (DECAY)	1	R11	20 kΩ or 22 kΩ	---
Resistor	1	R13	1 kΩ	---
Resistor	1	R15	10Ω or 12Ω, 1/2W	---
Resistor	2	R17, R18	180Ω or 150Ω, 1% or 2%, 1/2W	R17 and R18 must have equal resistance
Diode	2	D1, D2†	Any small rectifier diode	I used 1N4937 (1N4935, 1N4004, ...)
Zener diode	1	Z1	13V, 5W, optional	ON Semi 1N5350BRLG, Mouser 863-1N5350BRLG
Fuse, miniature pin	1	F1	8.5 mm, 1/4A time lag, optional	Schurter 0034.6709, Mouser 693-0034.6709
Pin receptacles for F1	2	---	To fit above, optional	I wired it in; pins from an IC socket could be used.
LED	2	LED1, LED2†	Small diam, any color, optional	For polarity, see sidebar on page 24.
LED	1	LED3	Small diam, any color, optional	For polarity, see sidebar on page 24.
Transistor, N-channel MOSFET , or NPN bipolar	2	Q1, Q2†	MOSFET 0.2A, or bipolar 0.2A, β ~ 50 minimum	ZVN4206ASTZ, Mouser 522-ZVN4206ASTZ 2N7000 also worked, although I prefer the higher current ZVN4206ASTZ
Operational amplifier	1	U1	High-Z input, input offset voltage of 3 mV or preferably lower	LF411ACN Mouser LF411ACN/NOPB, or Jameco 23018; Note 3
Optocoupler	2	U2, U3	BJT output, min current transfer ratio 50%	PS2501-1 or PC017; Note 4
Dual JK FF IC†	1	U4	Schmitt-trigger CL inputs, negative going clock, CMOS	74HC73N
Jumper pins and jumpers†	4	SW1A, SW1B, SW1C	Three-pin	SW1C is two three-pin jumper pins in parallel
Rotary switch	1	SW2	SP, as many positions as desired	---
Relay	1	RL1	SPDT, 12V, 280Ω coil, 16A contacts, or same as RL2 with contacts connected in parallel	TE Connectivity RTD14012, Mouser 655-RTD14012; Note 5, or same as RL2
Relay	1	RL2†	DPDT, 12V, 280Ω coil, 8A contacts	TE Connectivity RT424012, Mouser 655-RT424012; Note 5
IC socket, for U1, U2+U3	2	---	Eight-pin DIP	U2 and U3 share one eight-pin DIP socket
IC socket, for U4†	1	---	14-pin DIP	---
Hookup wire	As req'd	---	---	See hint in sidebar on page 25.
Solder	As req'd	---	---	---
Enclosure	1	---	As desired, approx 3"W x 6"L x 2"H	I used a RadioShack 270-1805
Perf board	1	---	0.1" hole spacing, to fit enclosure	For the RadioShack 270-1805 enclosure, I used a 2.6" x 4.9" perf board.
Binding posts	4	---	As desired	I used mini "five-way" binding posts.

PARTS LIST

R15, R17, and R18 are 1/2W; all other resistors are 1/8W, 5% (however, I used 1/4W because I had a large number on hand).

You will probably need to buy the parts in **bold**, which are unlikely to be in your recycle bins.

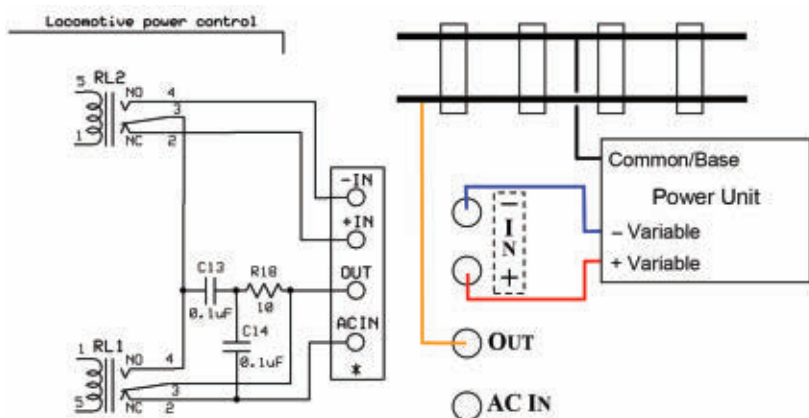

■ **FIGURE 11.** Alternative relay arrangement and wiring to maintain the common power connection to the same rail for DC mode. This requires both + and - voltages from the power unit. (In AC mode, the common power connection does not change.)

If everything checks out, power down, insert the other ICs (check the orientation), put the jumpers (SW1A, SW1B, and SW1C) into AC position, power up, and continue.

Set the op-amp gain using R7 "GAIN" as follows. If you have an oscilloscope, speak into the microphone and increase the gain until the output of the op-amp (pin 6, Point A, referred to the midpoint voltage, Point D) is clipping on loud sounds. Alternatively, connect either an oscilloscope or a voltmeter (an analog voltmeter works best) from Point C to ground (0V) and increase the gain until the voltage rises to about 6V when you speak. Alternatively, with the circuit in AC mode, increase the gain until LED1 flashes on when you speak. (LED2 should remain dark.)

parts of words, and also the delay between commands and the train's response will be suspiciously long. Some adjustment of GAIN (R7) may be required along with the DECAY adjustment (R11). Recheck the op-amp output voltage as described above. Finally, using an ohmmeter, check that continuity is interrupted between the +IN and +OUT binding posts for each command sound.

Next, power down, switch the jumpers to DC mode, and power up. Speak some commands, and check that LED1 and LED2 cycle through the sequence shown in **Figure 6** and **Table 1**. Finally – using an ohmmeter – check the continuity and non-continuity among the four binding posts using **Table 1** as a guide.

A Non-Functional Unit

First, check that the wiring is correct and the connections are actually connected. Often, I find that the problem is a faulty connection. Is LED3 lighted? If not, is LED3 in the correct orientation? Check the output of the power converter. If it's okay, is the zener diode Z1 in the correct orientation? Did you count the IC pins in the proper direction (clockwise when viewed from the bottom)? Are the transistors Q1 and Q2 connected correctly – not S (source) and D (drain) interchanged? What about the orientation of D1 and D2? If reversed, Q1 and Q2 could be damaged.

Try to locate the area of the fault. Using a voltmeter (or preferably a scope), check the following: When you speak, is there an audio signal waveform of about 10V P-P at the op-amp output (pin 6, Point A in **Figure 3**)? At

Table 2 — Examples of commands.

If the train is:	And you want it to:	You can say:
Stopped after reverse (state Sr)	Go forward	"Go" or "Forward" or any other <i>single</i> sound
	Go in reverse	"Now ... back ... up" or any <i>three</i> sounds
Going forward (state F)	Stop	"Stop" or "Halt" or any other <i>single</i> sound
	Go in reverse	"Now ... reverse" or "Back ... up" or "Re ... verse" or any <i>two</i> sounds
Going in reverse (state R)	Go forward	"Now ... forward" or "For ... ward" or "Go ... ahead" or any <i>two</i> sounds
	Stop	"Stop" or "Halt" or any other <i>single</i> sound
Stopped after forward (state Sf)	Go forward	"Go ... forward ... now" or "Go ... for ... ward" or any <i>three</i> sounds
	Go in reverse	"Go" or "Reverse" or "Back up" or any other <i>single</i> sound

Point C, the voltage measured from ground should rise to approximately 6V and fall for every sound pulse; there should be no AC component.

If all is okay to this point, in DC mode check the operation of the FFs using **Table 1**. Next, check the gates of the MOSFETs (Q1 and Q2) to see that they are receiving switching pulses. If not, they may be damaged. Are LED1 and LED2 in the correct orientation? By now, you should have discovered the area of the problem and a way to correct it.

Using the Train Voice Command

Set the jumpers (SW1A, B, C) for your locomotive's electrical power system (AC or DC mode) and connect the wiring for the train power appropriately as shown in **Figure 5**. Set the speed control of the train's transformer or power unit for the desired speed.

For AC mode, ensure that the locomotive's sequencing mechanism (E-unit) is not locked out with its lockout lever or switch.

In DC mode, the power connections are reversed when the locomotive is sequenced to "reverse." The train's power unit common output is transferred to the "hot" rail and vice versa. This may not work for some arrangements. A solution is to provide both positive (+) and negative (-) power for the loco and use the relay arrangement in **Figure 11**.

You will need some practice. For AC mode, LED1 will help by showing the sound pulses used to interrupt the power. For DC mode, LED1 and LED2 will show the switching sequence (**Figure 6** and **Table 1**). You may need to adjust the GAIN and DECAY. Here are a few examples (also see **Table 2**):

Suppose that the train is stopped and you know that it

was in reverse before it stopped. To command it to go forward, you can simply say "go" or "forward" if you make "forward" one continuous sound (indicated here by underlining). In other words, you are switching from state Sr to F. By "one continuous sound," I mean that only one pulse is produced.

Now you can say "halt" or "stop" to stop the train, going from F to Sf. Next, you can say "back" or "reverse" or "back up" (making "reverse" or "back up" one continuous sound) to go from Sf to R. The DECAY adjustment is what allows "back up" to act as one continuous sound and produce one pulse.

As a final example, if the train is stopped after going forward (Sf) and you want to go forward again (F), you will need three pulses. So, you could say "now ... go ... forward" or "go ... for ... ward," splitting the word "forward" to produce two pulses.

Be careful when saying "stop" or "up" that the final "p" isn't a separate sound producing an additional pulse. Try to cut it off or speak across the mike rather than into it. On the other hand, sometimes you may want "stop" to be two separate sounds.

With a little practice, you can make one word cause two pulses (by separating sounds) or two words make one pulse (by running sounds together). The length of the pulses is not important, except that if they are too long, onlookers will become suspicious (for example, for the intermediate stop between forward and reverse). Again, this depends on the DECAY adjustment.

Other languages will work as well: French (avant, arrière, arrêt ...); Spanish (vaya, deje de, atras ...); German (vorwärts, halt, zuruck ...); etc., or make up your own language or set of commands.

With some practice, you will get the hang of it. Have fun! **NV**

NOTES

1. I have tried several microphones and they all worked, including: Goldsun EC928-602 (Jameco 2099622, discontinued), Jameco Valuepro EM-99-R (Jameco 320179), Jameco Valuepro AMF-097A40-NB1-LF (Jameco 1950948), Kobitone 254-ECM970-RO (Mouser 254-ECM970-RO), DB Unlimited MO064404-1 (Mouser 497-MO064404-1) (small diam), Emkay 3340 LN100, CZN-15E, and two mystery microphones.

Different microphones may require different amounts of op-amp gain (R7). Observe the polarity when wiring the microphone.

2. If Q1 and Q2 are MOSFETs, anything from 0Ω to 47 kΩ should work for R1; R2 (and C8) may be altered, but R2 x C8 should be approximately 0.05-0.1 Ω-farad (approximately 0.05-0.1 second time constant). If Q1 and Q2 are BJTs, use between 3.3 kΩ and 4.7 kΩ for both R1 and R2.

3. The preferred op-amp is LF411ACN (Mouser LF411ACN/NOPB; Jameco 23018) which has low input offset voltage. However, if you have them on hand, you could try LF356N or TL081B if the op-amp output voltage (pin 6, Point A) measures within a few tenths (+ or -) of the midpoint voltage (Point D).

4. I have tried many other optocouplers, some new and some from my recycle bin including: Toshiba TLP621-2 (dual eight-pin); Sharp PC123, PC817, and S21MT1; Vishay TCET1102 and TCET1109; and NEC NEC2501, NEC2561, and NEC2561-A, all of which worked. A single dual anti-parallel-input optocoupler could be used (for example, type FOD814A).

5. Check that the contact current rating of the relays is adequate for your locomotive. If using RTD14012, note that there are two pins for the pole and two pins for each contact (NO and NC).

Build the TOILET SENTINEL

By Larry Cicchinelli

Post comments on this article and find any associated files and/or downloads at www.nutsvolts.com/magazine/article/October2016_Toilet-Sentinel.



Several months ago, our toilet ran for several hours because the flapper did not seat properly and we did not hear the water continuing to run. Since I had recently built a couple of projects using PIC processors, I thought I would try to build what I call a Toilet Sentinel.

For those of you who have or are interested in home automation, header H2 is a bit-banded serial port. It is fixed at 300 baud, eight data bits, and two stop bits. The only signaling which has been implemented is that of the normal flush operation:

“E” for start of flush
“I” for end of flush
“P” for problem

For instance, this signal could be connected to a ZigBee transmitter which transmits to your home automation system.

In reviewing the various PIC

processors, I wanted one with as few pins as I could get which would meet my I/O requirements. I also wanted one which had very low power consumption so it could run from a single cell for at least a year. I finally selected the 12LF1572. This is an eight-pin device with low current drain — about 10 μ A when idling using its 31 kHz internal oscillator as the CPU clock. My previous projects used PICs from the 18 series which has non-paged I/O and RAM, so I was a little skeptical about the paged memory in the 12 series devices. The paged I/O did “catch” me a few times, but it was not too difficult.

There are fewer instructions in this PIC as compared to the 18 series, but the only ones I really missed were the conditional branches. It was sometimes confusing using the skip operations, but as long as I documented the code properly I managed okay.

In looking over the code, I still sometimes do a double-take when I see a skip instruction followed by one or two GOTO statements. Also, even though the clock frequency is 31 kHz, the instruction execution time is about 8 kHz. If you want to do some debugging, be aware that single stepping takes about 20 seconds per step.

I gave a lot of thought to finding the most cost-effective method of detecting the water level. I probably spent more time on this effort than any other phase of the project. At first, I was going to use a commercial water level sensor; however, the units I found turned out to be too expensive for my purpose. The sensor I decided upon is simply two parallel wires terminated with gold plated contact pins (see **Figure 1**).

I initially used the wire ends stripped back about 1/2". However, after about a month, there was enough oxidation on them that they stopped working. The gold plated pins will last a lot longer. I used some gold plated "D" connector pins which I happened to have in my stock of parts. If you want to get a little more robust, you can use stainless steel bolts instead.

These two pins and the water between them form a switch which is "closed" when the pins are submerged. As you can see from the **schematic**, the circuit is very simple and has very few components, with a total cost of under \$10. The printed circuit board (PCB) is approximately 1" x 1.35" and fits easily into a low cost "potting" box (see **Figure 2**).

I purchase most of my parts from Digi-Key since they have free shipping if a check is included with the order. If you use this service, be sure to include whatever sales taxes are applicable.

System Operation

The operation of the system is quite simple. When the unit is first powered up, it goes through a calibration cycle requiring you to flush the toilet once. It measures the amount of time between when the water drops below the level of the sensors to when the sensors are submerged again. This time – plus a 25% pad – is used as the basis for determining whether or not future flushes finish on time.

If the system detects that too long a time has occurred before the tank becomes full again, a warning signal is sounded via an audio transducer (buzzer).

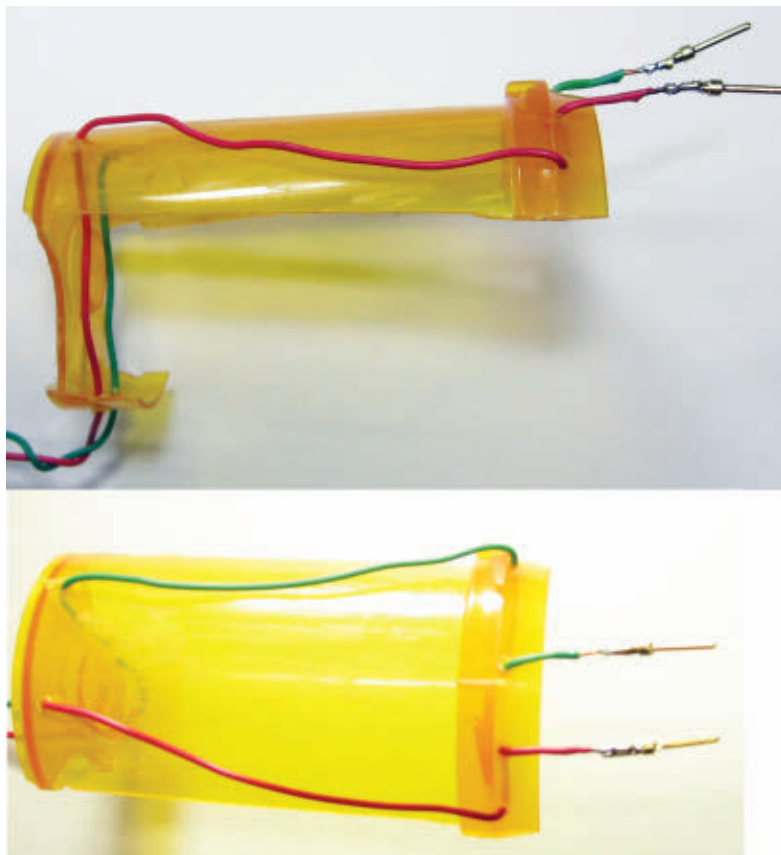

■ **FIGURE 1.** Two views of the sensor showing the pill container as cut with a Dremel tool. The top photo shows a small lip which allows it to hang quite nicely on the back of my tank.

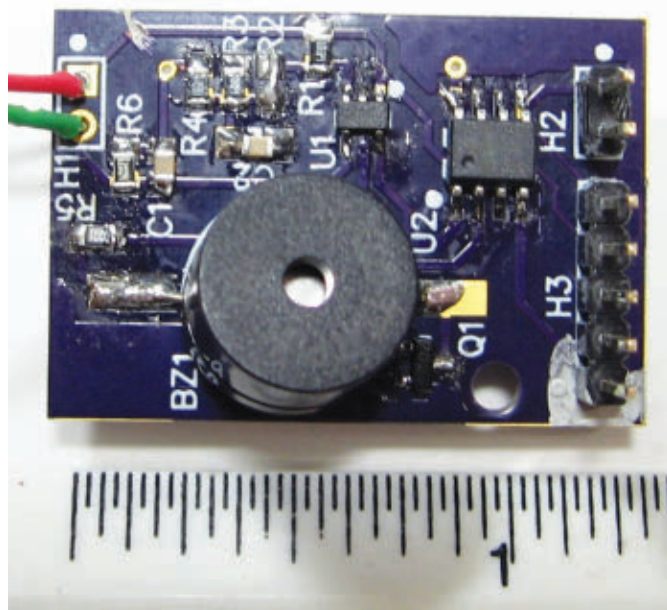

■ **FIGURE 2.** As you can see, the circuit board is quite small. The battery mounts on the bottom side and is kept in place by the battery holder.

The op-amp is used as a switch buffer and inverter with hysteresis. The amount of hysteresis is dependent on the values of R1, R3, and R4. Using Kirchoff's Current Law and the feature of an ideal op-amp of infinite input resistance, the equation for the voltage at pin 3 of the op-amp is:

$$\frac{VDD - V3}{R3} + \frac{V1 - V3}{R1} = \frac{V3}{R4}$$

If R1, R3, and R4 are equal, the formula reduces to:

$$V3 = \frac{VDD + V1}{3}$$

where V1 is the voltage at pin 1 and V3 is the voltage at pin 3. The voltage on the output pin, V1, will be either VDD or ground; therefore, V3 will be either 2*VDD/3 or VDD/3. With a 3V battery, these voltages will be 2V or 1V, yielding a 1V hysteresis band.

Note that if you want to measure the voltage divider value at pin 4, you need to take into account the input resistance of your voltmeter since most are 10 megohms and R6 is 3 megohms. The voltage at pin 4 must measure at least 1.81V when the probes are submerged if you are using a voltmeter with a 10 megohm input resistance.

When there is water between the sensor pins, the circuit is "on" and the voltage at pin 4 will be high: >2V. This will cause the output voltage to go low: 0V. When

there is no water between the wires, the circuit is "off" and the output voltage will be high: 3V. The program in the PIC recognizes these voltages as "tank full" and "flushing," respectively.

As you can see from **Figure 1**, the sensor assembly is rather simple. I used a plastic pill bottle I had laying around and cut it using my Dremel tool. I sectioned the bottle so that it hooks over the edge of the tank. I drilled several holes in the bottle where I ran the sensor wires so that they stay in place.

The buzzer is used during both normal operation and calibration. The program uses a series of long (300 ms) and short (100 ms) beeps; some are Morse code characters to indicate several states:

Calibration signals:

short, long, short = R: program Running
 short, short, long, short = F: initiate a Flush
 battery check
 sound the number of seconds in binary (see text below)
 short, long, short, short = L: flush time too Long (>192s)

Normal operation signals:

battery check
 short, short = flush complete
 short, long, long, short = P: problem

Battery check:

short = battery OK
 long, short, short, short = B: battery low

At the end of the calibration cycle, the number of seconds the system measured is sounded by the buzzer. The beeps starts with the most significant "1" in the binary value, so the first beep is always a long. For example, a value of 60 (b0011 1100) seconds would be represented by: long, long, long, long, short, short. A single short is used for the battery OK signal because it saves on the battery.

The buzzer uses one of the PWM channels set to divide the CPU clock frequency by 16, yielding close to 2 kHz. This is quite close to the resonant frequency of the buzzer which is specified as 2,048 Hz ±500 Hz.

In order to minimize power drain, the PWM channel is enabled only when the program needs to generate a beep.

A battery check is done at the beginning of every flush cycle. The A/D converter in the PIC is used to measure the FVR (Fixed Voltage Reference) of 1.024 volts.

Since the A/D uses VDD as its positive reference, whenever VDD drops

■ SCHEMATIC.

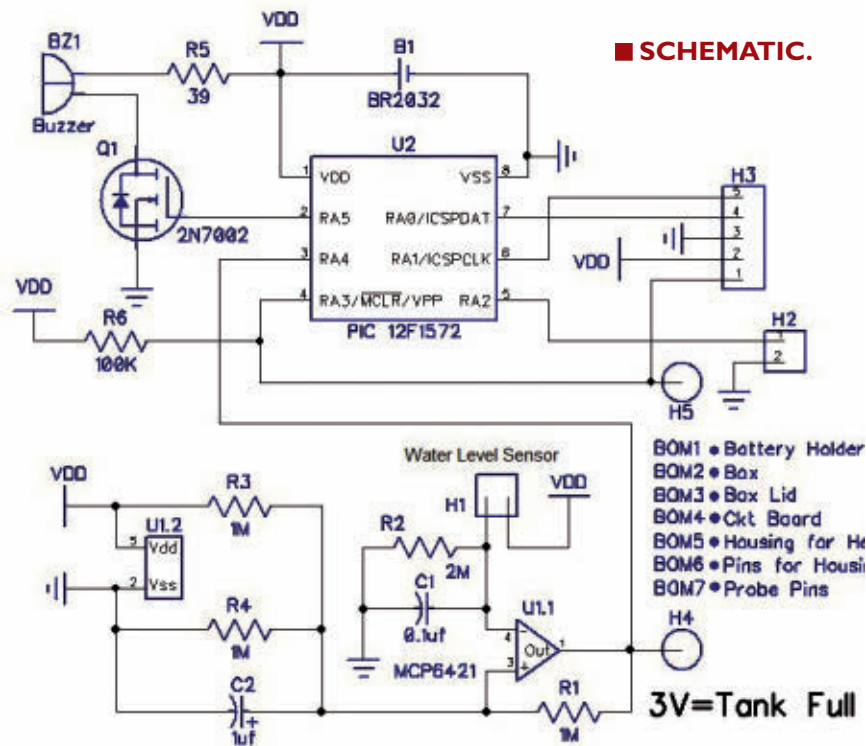

below 2.048V, the FVR will measure over 1/2 scale. All the program does is look at the most significant bit of the A/D conversion. If it is on, then the battery voltage is low and the program sounds the "battery low" signal.

When you first insert the battery, the program forces a calibration cycle. You will first hear an "R," to indicate that the program is Running. Then, you will hear an "F" which is a Flush request. Once a flush is detected, a battery test will be performed so you should hear one short beep. When the tank has refilled, you will hear the number of seconds it took to fill as described above.

You can force a reset by shorting pins 1 (/MCLR) and 3 (ground) of H3. The /MCLR signal is also on H5 which is 0.1" from H1 pin 3. This allows you to use a small screwdriver to short the pins to force a reset. Note that if you power the unit before inserting the probe into the tank and /MCLR is not grounded, the program will detect that a flush is in progress.

The circuit draws less than 20 μ A continuously; however, I used that value in my calculation for battery life. The buzzer device draws about 50 ma for 150 ms (300 ms with a 50% duty cycle) for each normal flush cycle — assuming no problems.

These values yield 480 μ A-hours/day of continuous current, and about 83 μ A-hours per day for the buzzer — assuming 40 flushes per day. The sum of these two values divided into the 0.25 amp-hour rating of the battery yields about 443 days of operation.

The source code for the program is available at the article link, as well as my own website at www.qsl.net/k3pto/. If you do not have a PIC programmer or access to one, I will be happy to program one for you if you send me your PIC and include an SASE. Be sure to include an email address in case I need to contact you.

All my design files are at the article link as well. I use DipTrace (www.DipTrace.com) for all of my PCB designs. A fully functional free version is available from their site.

Most recently, I have been using

OshPark (www.oshpark.com) for my circuit boards. Their cost is \$5 per square inch, but you get three copies of the board for that price which also includes shipping. If you want a single board, I would be happy to mail you one at cost if you send me an SASE.

Or, you can go to my page on the OshPark website (<https://oshpark.com/profiles/k3pto>) and order directly from them. Keep in mind that you will get three copies of the same board.



Get the Parts You Need FAST!

HIGH QUALITY ELECTRONIC COMPONENTS
IN STOCK AND READY TO SHIP

ntepartsdirect®
Quality is Always In-Stock

- Consumer, commercial, industrial and MRO applications
- Huge product inventory
- Wide selection and complete specs
- No minimum order
- Cross referencing for thousands of parts
- Same day shipping available

ORDER TODAY!

www.ntepartsdirect.com

A Few Assembly Notes

None of the three headers are absolutely necessary. You should solder the leads from the sensor directly into the holes where H1 would be installed since the box is not tall enough to accommodate the mating housing.

If you are not going to program the PIC on the PCB, then H3 is not necessary. If you do want to use the headers, the part numbers and quantities in the **Parts List** have enough pins for all three headers. You simply need to cut them to size.

Although a crimper makes the job of assembling the pins for the housings easier, it is not required. Before I got a crimper, I used a pair of small needlenose pliers to crimp the wires to the pins. It took a little practice (with several failures), but I did learn how to do it.

Take a look at **Figure 3** for a sample of what the housings and pins look like.

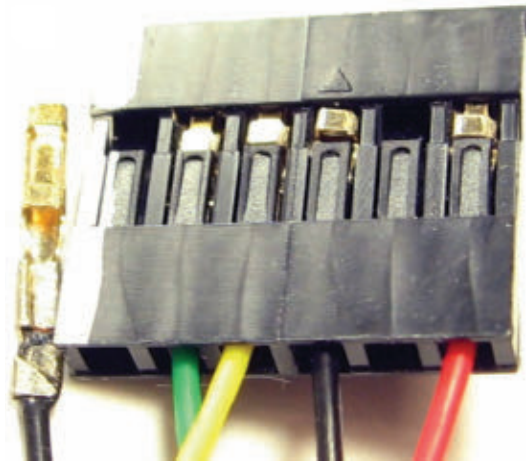

■ **FIGURE 3.** Close up of a sample header which I use for programming my PICs.

solder the remaining pad(s).

There is a sizable pad on the bottom of the board for the negative surface of the battery – you should apply a smooth covering of solder to ensure good contact.

Although there is a mounting hole in the PCB for a 4-40 bolt, I leave the PCB floating and use a rubber band to hold the lid onto the case.

Note that the buzzer is polarized. The PCB silk screen shows which terminal is the positive. Also, you will need

to bend the leads in order to surface-mount it.

I filed a notch in the lid for the sensor wires and drilled a hole in the lid to allow more sound out.

CAUTION: There is no protection against polarity inversion! Please be sure to insert the battery with the negative side against the board.

I hope you find this circuit as helpful as I do. **NV**

Ref/Des	Value	Name	Qty	\$/ea	\$ Total
B1	BR2032	P189-ND	1	\$0.28	\$0.28
BOM1	Battery Holder	BAT-HLD-001-ND	1	\$0.28	\$0.28
BOM2	Box	377-1692-ND	1	\$0.45	\$0.45
BOM3	Box Lid	377-1693-ND	1	\$0.37	\$0.37
BOM4	Circuit Board	see text	1	\$2.10	\$2.10
BOM5 *	Housing for Headers	WM5341-ND	1	\$0.60	\$0.60
BOM6 *	Pins for Housing	WM2562CT-ND	10	\$0.11	\$1.14
BOM7	Probe Pins	609-1474-ND	2	\$0.10	\$0.20
BZ1	Buzzer	668-1097-ND	1	\$1.13	\$1.13
C1	0.1 μ f	311-1335-1-ND	1	\$0.09	\$0.09
C2	1 μ f	1276-1119-1-ND	1	\$0.18	\$0.18
H1, H2, H3 *		S1012EC-20-ND	1	\$0.36	\$0.36
Q1	2N7002	568-5818-1-ND	1	\$0.14	\$0.14
R1, R3, R4 **	1M	311-1.00MCRCT-ND	10	\$0.02	\$0.21
R2	3M	311-3.01MCRCT-ND	1	\$0.10	\$0.10
R5	39	311-39.0CRCT-ND	1	\$0.10	\$0.10
R6	100K	311-100KCRCT-ND	1	\$0.10	\$0.10
U1	MCP6421	MCP6421T-E/OTCT-ND	1	\$0.53	\$0.53
U2	PIC12F1572	PIC12F1572-I/SN-ND	1	\$0.60	\$0.60
				Total cost	\$8.96

These parts are only necessary if you are going to use the headers and mating housings.

The listed part numbers, and quantities, are adequate for all three headers. Buying 10 is cheaper than buying three. Prices are subject to change without notice.

PARTS LIST

By Craig A. Lindley

Make Your Own Portable Media Center

My wife and I like to travel in our small Rialta RV. We usually dry camp without connecting up to any services like power, water, or sewer, but sometimes we need to take showers or do laundry so we opt for a commercial campground. When we are in a commercial campground, we will connect up to at least power which gives us the ability to watch movies or listen to music using a portable media center that I will describe in this article.



When we bought our RV, it had a TV/monitor that we really didn't use. When I realized it had an HDMI input, I immediately thought of the Raspberry Pi. I started wondering what I could design that would enhance our RVing experience. Of course, playing movies first came to mind, but I didn't want to use a DVD player because that would take up precious space in our already compact RV. In researching how one might play digitized movies with a Rasp Pi, I came across OpenELEC which is an embedded Linux operating system built around Kodi: the open source entertainment media hub.

Kodi describes itself this way:

"Kodi® (formerly known as XBMC™) is an award-winning free and open source (GPL) software media center for playing videos, music, pictures, games, and more. Kodi runs on Linux, OS X, Windows, iOS, and Android. It allows users to play and view most videos, music, podcasts, and other digital media files from local and network storage media and the Internet."

OpenELEC (upon which Kodi runs) is different from

other versions of Linux because:

"OpenELEC is built from the ground up specifically for one task: to run Kodi. Other operating systems are designed to be multi-purpose, so they include all kinds of software to run services and programs that won't be used. OpenELEC, however, only includes software REQUIRED to run Kodi. Because of that, it is tiny (roughly 150 MB), it installs literally in minutes, and, it can boot extremely quickly in 5-20 seconds, depending on the hardware type used."

OpenELEC can automatically update itself and can be managed entirely from within the graphical user interface (GUI) it presents. Even though it runs on Linux, you will never need to see a management console, use a command line, or have Linux knowledge to use it.

In the home environment, Kodi is generally controlled with a mouse and keyboard, but I didn't want to carry those items around in our RV either. So, I found a free remote control application for my Android tablet called "Kore" which provides wireless remote control of Kodi for our media center. There are equivalent apps for controlling



FIGURE 1. All of the required parts. The microSD card cannot be seen because it is inserted in the socket underneath the Raspberry Pi.

Kodi in the iTunes app store, as well as for iOS devices.

Of course, remote control requires Wi-Fi for communication between the tablet and the media center, but here also, OpenELEC comes to the rescue. With the correct Wi-Fi adapter connected to the RaspPi (more on this in a moment), OpenELEC can run as an AP, or Access Point (called Tethered Wireless Access Point in the OpenELEC user interface), thereby creating its own Wi-Fi network when no other Wi-Fi network is available. This way, we can use our tablet to control our media center while in a campground that doesn't have Wi-Fi. Pretty slick if you ask me.

Unlike most of my articles for *Nuts & Volts*, this one doesn't have any code you have to configure or compile, or hardware you have to wire up or solder. For this project, you collect the required parts, assemble the hardware, load the OpenELEC software, gather up your media, and you will be ready to go. I'll give you detailed instructions on how to do this in the text that follows. First though, let me describe my system to show you what is

possible for a media center you can literally hold in the palm of your hand.

In my system, I use a 128 GB Flash drive for holding all of my digital media files. On this drive, I have 34 full length movies, approximately 30 TV shows, and 500 CDs of music, and I still have 53 GB available for other things. I could load a bunch of our photos onto the Flash drive and use the slide show feature of Kodi, but I haven't got around to that yet. As you can see, with this kind of content you could be entertained for weeks on end. If you travel with a digital camera and a laptop, you could download all the pictures you took during the day and then copy them to the Flash drive of the media center to view them in the evenings and/or just to back them up.

On a final note, when we aren't traveling, I use our portable media center in our living room with our large screen TV. It works just as well there as in our RV.

Software

Two pieces of software are required for the media center. First and most important is OpenELEC itself, and the second is Kore, the remote control application.

OpenELEC

The OpenELEC software can be downloaded from the link provided in the **Resources** section. The current version at the time of this writing was 6.0.3, although a version 7 is in beta testing. Before downloading the software, make sure you identify the correct version for the RaspPi 2 and 3. Also get the one marked *Diskimage* instead of the one marked *Update File*. Once you have identified the correct version, download it to your computer.

The next step in the process is to decompress the downloaded file. How this is done depends on the computer platform you are using. On my Mac in the OSX environment, this is as simple as double-clicking the downloaded file; it decompresses automatically. In the Windows 10 environment, I had to first install 9Zip from the Microsoft app store and then use it to decompress the file. In either case, you end up with a file called

DESCRIPTION	ITEM	SOURCE
Raspberry Pi Single Board Computer	Pi 3 Model B or Pi 2 Model B Pi 2 Model B	adafruit.com mcmelectronics.com sparkfun.com amazon.com
Protective Case	Enokay Black Case for Raspberry Pi 2/Pi 3 Model B/B Plus	amazon.com
USB 2.0 Wi-Fi Adapter	CanaKit Raspberry Pi Wi-Fi Wireless Adapter or any Adapter with a Ralink 5370 Chipset	amazon.com
microSD Memory Card	Sandisk 2 GB microSD Memory Card with SD Adapter	amazon.com
USB Power Module	Any type capable of two amps at five volts	amazon.com
USB 2.0 Flash Drive	PNY Attaché 64 GB or 128 GB	amazon.com
HDMI Cable	High Speed HDMI Cable	Anywhere
USB 2.0 Cable for Power	Type A to micro B	Anywhere

**PARTS
LIST**

OpenELEC-RPi2.arm-6.0.3.img which is the Linux disk image we need to put on a microSD card for the RaspPi in the media center.

Both my Mac and Windows 10 computer have a slot for reading and writing normal SD memory cards. The microSD card specified in the Parts List comes with an adapter allowing the microSD card to be used in a normal SD card slot. It doesn't matter how you get the image file onto the microSD card; it's only important that you do.

How one copies a Linux image file to an SD card also depends on the computer platform being used. Instructions for OSX (Section 3.3), Windows (Section 3.2), and Linux (Section 4.4) can be found at http://elinux.org/RPi_Easy_SD_Card_Setup. Because the OpenELEC image is so small, writing it to the microSD card happens quickly – much quicker than when writing a full-on RaspPi operating system image.

Remote Control

As mentioned, Kore is a remote control application for the media center that can be downloaded for free from the Google Play Store for Android devices. On my Nexus 7 tablet, I first click the icon for the Play Store from the home screen; then in the search bar, type in Kore. You will see numerous versions of it, but the one I use is called “Kore, Official Remote for XBMC Foundation” as it seems to have some kind of official sanction.

Once you have Kore installed, you execute it by tapping its icon. Kore will immediately try to identify all OpenELEC installations on the Wi-Fi network to which it is connected. If it finds your media center, click on it to indicate it is the one you wish to control. This process should only need to be done once unless connection parameters change.

After playing with Kore for a while, its operation should become second nature as using Kore is a lot like using a normal TV remote.

I should mention there are many different ways to control your media center, but Kore for Android is the method I have chosen. Google “Kodi remote control” if you would like to see what other options are available.

Hardware

Before assembling the media center, collect all of the items in the **Parts List** and what is shown in **Figure 1**.

NOTE: Most of the parts specified are non-critical and other brands can usually be substituted successfully. My media center worked right out of the box with the parts listed here. Your mileage may vary if you substitute items.

Almost any USB 2.0 Wi-Fi adapter can be used with OpenELEC. However, if you want to use the AP or tethered

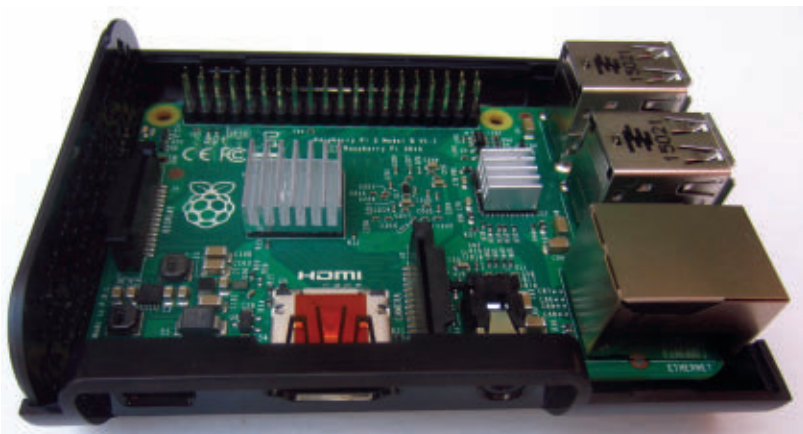

FIGURE 2. Raspberry Pi with heatsinks installed.

mode, you must have a Wi-Fi adapter that supports AP operation; many don't. The adapter shown in the **Parts List** was chosen because it does. From my research, it seems any Wi-Fi adapter using the Ralink 5370 chipset can support AP mode. You can use whatever Wi-Fi adapter you have on hand if AP mode is not important to you.

In the **Parts List**, I specified that either a RaspPi 2 model B or a 3 model B can be used in the media center. I initially had a Pi 2 in mine and it worked for the most part, but every now and then I would experience pauses in the video that lasted up to about 20 seconds, making for difficult movie viewing. I have since replaced the Pi 2 with a Pi 3, and the video playback is now flawless. In researching this issue, I came across many people that don't seem to have any troubles with the Pi 2, so it may have just been something amiss in my original installation. For now, I'll leave the Pi 3 in my media center and use the Pi 2 for some other project.

Assembling the media center could not be easier and consists of the following steps:

1. Copy the OpenELEC software image onto a 2 GB or larger microSD card.
2. Insert the microSD card into the RaspPi.
3. If heatsinks are available, pull off the adhesive backing and press them firmly onto the black chips on the RaspPi board.



FIGURE 3. Raspberry Pi safe in its protective case.



FIGURE 4. Bottom of the media center case. Note the Velcro strips which hold it to the back of the display in both our RV and home TV. Securing it to the back of the display means it takes up zero additional space.

4. Place the Pi into the bottom of the protective case.
5. Snap on the top of the case.
6. Secure the two halves of the case together with the four included screws.
7. Plug in the Wi-Fi adapter.
8. Plug in the Flash drive containing your digital media files.
9. Connect an HDMI cable from the Pi to your TV/monitor.
10. Connect the USB cable from the RaspPi to the USB power adapter.
11. Turn on your TV/monitor and plug the power adapter in.

If all is well, in mere moments you should see the OpenELEC user interface appear on the display as shown in **Figure 5**.

After I verified the media center was working correctly, I put some Velcro® on the back of the case so I could attach it to the back of whatever TV/monitor I was using for display. That way, I can use it in the house when I want to and then easily move it to the RV for traveling.

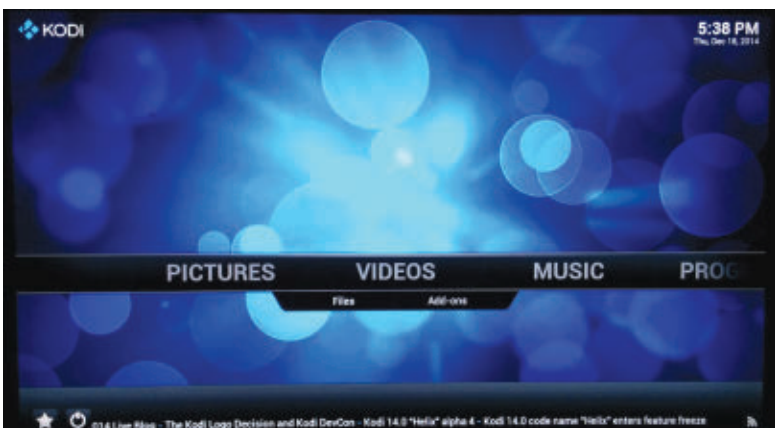

FIGURE 5. The OpenELEC user interface you will see upon successful installation (stock skin, but many others available).

Creating Media

Before discussing media creation, one first has to prepare the Flash drive for storage of the digital media. I did the following:

1. Formatted the 128 GB Flash drive with the **Win32** format. This may not have actually been necessary, but it made sure no other files would be on the Flash drive other than the ones I put there.
2. I then created a directory called MUSIC and a directory called MOVIES in the root directory of the Flash drive.

I did this on my Mac, but it is easily done on a PC as well. Creating digital media (movies and music) for your media center takes much more time than building the media center itself. Luckily, in my case, I already had a large music library of about 500 CDs that I had ripped over time. I use iTunes to manage my music, so all I had to do was copy the entire iTunes library of aac (m4a) files to the MUSIC directory on the Flash drive. Now, that was easy!

Kodi can play many music formats, so if you have a collection of mp3 files, for example, you can copy them to the MUSIC directory. Also, Kodi doesn't require all of the digital music files to be of the same format, so you can essentially load any music you have onto the Flash drive.

Video media, on the other hand, took some time to create. I have a rather large collection of DVDs, so I had to rip the movies I wanted to have on the media center into a format that Kodi can play. Being the frugal individual that I am, I searched the web for free DVD ripping software and came up with a program called HandBrake which does the job nicely (see the **Resources** section for a link for downloading HandBrake). Handbrake is available for OSX, Windows, and certain varieties of Linux.

HandBrake refers to itself as "The Open Source Video Transcoder." This means it can convert from DVD format to many different output video formats, with one important exception. It cannot transcode videos that are protected with the Content Scramble System (CSS) which is a form of Digital Rights Management (DRM) meant to prevent illegal copying. To get around this impediment, you can install a library called *libdvdcss* on the computer system you are planning on using to rip the DVDs and it will remove the DRM information during the transcoding process. See the **Resources** section for where you can acquire this library and how you go about installing it. As I understand it, I have the right to make a backup copy of any DRM protected media I personally own so I have no problem doing this.

Once you have HandBrake downloaded and installed, it is easy — though time-consuming — to rip a DVD for the media center. A normal length movie takes about 25 minutes to rip on my Mac, so it is best to start the process and go do something else.

I used all of the HandBrake defaults (except I named the output files with the name of the movie) to rip my movies and they play back great. HandBrake produces m4v video files which I initially stored on the Mac, and then I would copy the ripped movies in mass to the 128 GB Flash drive. This seemed to be faster than ripping the movies directly to the drive, though that can be done as well.

Conclusion

It is easy to create a very powerful media center that fits in the palm of your hand, and that can keep you entertained for hours on end. This is a great and useful project for someone getting into the Raspberry Pi for the first time. It is almost impossible to mess up because there isn't any

Resources

OpenELEC media center software is available for free at <http://openelec.tv/get-openelec>. Make sure you pick the Raspberry Pi 2 and Pi 3 [Model B+ 512 MB] disk image.

Information on how to copy a Linux image file to an SD memory card can be found at http://elinux.org/RPi_Easy_SD_Card_Setup.

In this article, I only briefly touched upon what Kodi is capable of. With Kodi, you can play games, get current weather conditions, have slide shows, re-skin the app to change its appearance, and much more. Look up Kodi add-ons to see what is available for customizing your media center. For more information, go to <https://kodi.tv>.

HandBrake software for Windows, OSX, and UBUNTU Linux is available for free at <https://handbrake.fr>.

Instructions for downloading and installing *libdvdcss* are available at www.winxdvd.com/resource/install-handbrake-libdvdcss-to-rip-dvd.htm.

programming involved or Linux configuration necessary.

One advantage of going digital is that the media center is much smaller physically than the audio CDs and the video DVDs it replaces. All of those CD and DVD cases take up a lot of space.

Why don't you build yourself a personal media center today? It only takes an hour or so! That way, you can carry around a collection of your best loved music and videos in the palm of your hand or even in your back pocket. **NV**

FREE

PCB Layout Software & PCB Schematic Software

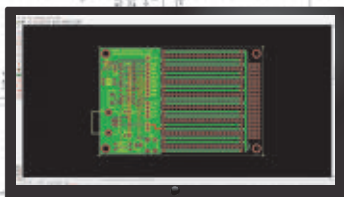

expresspcb.com

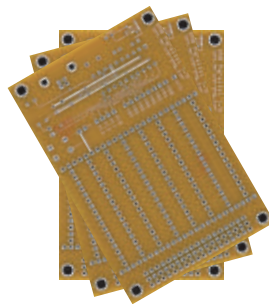

3 PCBs

\$41 + shipping

2-layer
MiniBoard

(Shipped in 1 business day)

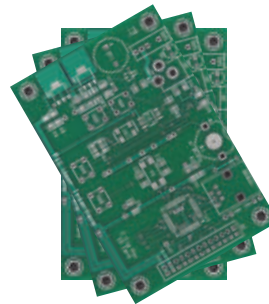

3 PCBs

\$61 + shipping

2-layer
MiniBoardPro

(Shipped in 2 business days)

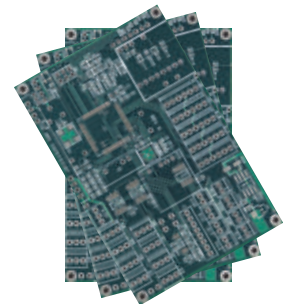

3 PCBs

\$81 + shipping

4-layer
MiniBoardPro

(Shipped in 3 business days)

- 1** **DOWNLOAD** our free CAD software
- 2** **DESIGN** your 2 or 4-layer PCB
- 3** **CHECK** your design with xCHECK DRC
- 4** **SEND** us your design with just a click
- 5** **RECEIVE** top quality boards in just days

Now Offering
SMT STENCILS
- Nano Coating available -



MADE IN THE USA | www.expresspcb.com

Choosing an Oscilloscope

By Alan Lowne
CEO Saelig Company (www.saelig.com)

Post comments on this article at www.nutsvolts.com/magazine/article/October2016_Choosing-Oscilloscopes.

All sorts of questions arise when choosing a new digital oscilloscope (DSO) — it can be somewhat daunting! Where will you use the scope (on the bench, at a customer's site, under the hood of a car)? How many signals do you need to measure at once? What are the maximum and minimum amplitudes of signals that you need to measure? What is the highest frequency of signal you need to measure? Are your signals repetitive or single shot? Do you need to view signals in the frequency domain (spectrum analysis) as well as the time domain? Cost is always a factor too.

Consider capturing good ol' USB1.1 data: A frame of data lasts 1 ms and has serial data transmitted at 12 Mbps (or a 12 MHz square wave for 1 ms). Bandwidth: To measure the 12 MHz signal, a scope needs at least 50 MHz bandwidth. Sampling rate: To reconstruct the 12 MHz signal, a minimum sampling rate of 60 MS/s is required for five points per waveform. Memory depth: Capturing data at 60 MS/s for 1 ms requires a minimum memory of 60,000 samples.

You will need to look at the following criteria:

Form Factor

Should you use traditional bench-top, handheld, or PC based scopes? A bench-top scope will usually have the highest performance — and cost, but it's ready to use as soon as you turn it on. Features such as mixed-signal capabilities and decoding options are often available at added cost. Handheld oscilloscopes have obvious advantages for an engineer on the move, but beware of poor displays (difficult to read in sunlight) and short battery life. For a



Handheld scope.

Check out these 15 things to look for!

given performance level, they also tend to be the most expensive option.

PC based oscilloscopes often offer cost-savings over their bench-top equivalents, and have the advantages of a large color display, faster processor, storage and data-sharing capabilities, and a keyboard for annotations. PC based scopes come in two flavors: internal and external. Internal PC based scopes are usually PCI or PCIe format plug-in cards and are tied to being used with one desktop PC. External PC based oscilloscopes like PicoScopes come in very portable small boxes that connect to a PC via a USB port. They can be used with desktop or laptop PCs, making them ideal for field use, as well as for bench top design and debug tasks. There are dedicated automotive PicoScopes with isolated inputs and adapters that are specifically designed for vehicle investigations.

Bandwidth

Bandwidth is the maximum frequency of signal that can pass through front-end amplifiers. Most scope manufacturers define the bandwidth as the frequency at which a sine wave input signal will be attenuated to 71% of its true amplitude (-3 dB point), i.e., the displayed trace will have 29% amplitude error. If the input signal is not a pure sine wave, it will contain higher frequency harmonics.

For example, a 20 MHz pure square



PC scope.

wave viewed on a 20 MHz bandwidth scope will be displayed as an attenuated and very distorted waveform. As a rule of thumb, buy a scope with a 5x higher bandwidth than the maximum frequency signal you wish to measure. Be aware that on some scopes, the quoted bandwidth is not available on all voltage ranges!

Sample Rate

For digital scopes, sampling rate and



Automotive oscilloscope.

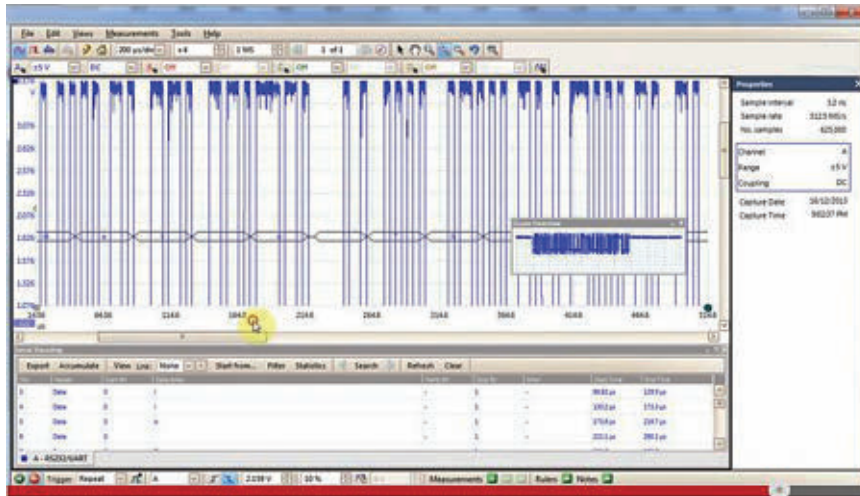

Memory depth.

memory depth are equally important. The Nyquist criterion states that the sampling rate must be at least twice the maximum frequency that you want to measure. For a spectrum analyzer, this may be true, but for a scope you require at least five samples to accurately reconstruct a waveform. Most scopes have two different sampling rates/modes depending on the signal being measured: real time and equivalent time sampling (ETS) — often called repetitive sampling. ETS only works if the signal you are measuring is stable and repetitive, since this works by building up the waveform from successive samples. Many scopes have different sampling rates, depending on the number of channels in use. Typically, the sampling rate in single channel mode is twice that in dual channel mode.

Number of Channels

Most scopes come with two channels so you can compare the relative timings of two signals. Four channels might be more useful to

you if you're working on stepper motors or cars, for instance. Eight channels are available on some PC based scopes, and they can even be synchronized in multiples in case you have the need.

Waveform Capture Rate

The waveform capture rate refers to how quickly an

oscilloscope acquires waveforms. If finding and debugging random and infrequent problems is important to you, then waveform update rates are an important consideration in choosing the oscilloscope for your measurements. Update rates directly determine an oscilloscope's probability of capturing and displaying random and infrequent events.

Memory Depth

Memory depth is perhaps the least understood aspect of a DSO — but is one of the most important. DSOs store captured samples in a buffer memory. So, for a given sampling rate, the size of the buffer memory determines how long it can capture a signal before the memory is full. A scope with a high sampling rate but small memory will only be able to use its full sampling rate on the top few timebases. A large memory will let you zoom in on small, fast, infrequent glitches. Bigger is better!

Resolution and Accuracy

Almost all oscilloscopes have eight-bit A/Ds, i.e., the voltage range is divided up into 256 vertical steps ($2^8 = 256$). With a $\pm 1V$ range selected, this equals around 8 mV per step. This may be okay for viewing digital signals, but is not the best for analog signals — especially when using the scope's FFT (Fast Fourier transform) spectrum analyzer function. In digital electronics, a signal change of 1% is usually no problem, but in audio and other analog



Probes.

electronics, 0.1% distortion or noise can be disastrous. With eight-bit resolution, you can detect at best a 0.4% signal change. For applications such as audio, noise, vibration, and monitoring sensors (temperature, current, pressure), an eight-bit oscilloscope is often not suitable, so you should consider 12- or 16-bit alternatives.

A DSO's accuracy is not usually regarded as too important. You can make measurements within a few percent (most eight-bit DSOs quote 3% to 5% DC accuracy), but a multimeter is better suited for more accurate DC and pure AC measurements. With a higher resolution oscilloscope, more accurate measurements are possible (1% or better). Oscilloscopes with both a high resolution (12 bits or more) and a high DC accuracy are often referred to as precision oscilloscopes.

Triggering Capabilities

A scope's trigger function synchronizes the horizontal sweep at the correct point of its signal. This is essential for clear signal characterization and a steady display. Trigger controls allow you to stabilize repetitive waveforms and capture single-shot waveforms. All digital scopes offer the same basic trigger options (source, level, slope, pre/post trigger) but differ in more advanced trigger functions. Pulse triggers are useful for digital signals, and an automatic save to memory option can be a great help when tracking down intermittent faults. Scopes now often offer pass/fail and mask capabilities too.

Input Ranges (and Probes)

Typical scopes offer selectable full-scale

At Saelig Co., Inc., we have assembled the widest range of affordable scope solutions, from introductory USB scope adapters at under \$120, to sophisticated yet economical stand-alone scopes, to high-end 12-bit 2/4 channel mixed-signal scopes that cover 1 GHz signals, as well as offering 8/16 channels of simultaneous logic analysis — even up to the world's fastest 12 GHz sampling scope adapter. Details at www.saelig.com/category/PS.htm.



FFT.

input ranges from ± 50 mV to ± 50 V. Higher voltages can be measured using 10:1 and 100:1 attenuating or isolation probes. An important factor is to check that the scope has a small enough voltage range for the anticipated signals.

If small signals (less than 50 mV) are often encountered, consider buying a scope with a 12- or 16-bit resolution. A 16-bit scope has 256 times the vertical resolution of an eight-bit scope, making it possible to 'zoom in' on millivolt and microvolt level signals.

Connectivity

Digital oscilloscopes usually offer a variety of connectivity capabilities. These can include RS-232, LAN, and USB 2.0 interfaces for control or data download. USB sockets for memory sticks are also useful for transferring data to PCs for reports, etc. Some oscilloscopes let you export waveform data as Excel files, while others only allow you to store screen captures as jpg images.

Both are useful for printing out results or entering into Word files. The ability to perform "hands-off" scope control via a PC may be vital to your needs or irrelevant, but worth considering.

Built-in Capabilities

Automatic measurements, built-in pass/fail analysis with relay output, and math functions can save time and make your life easier. Measurement

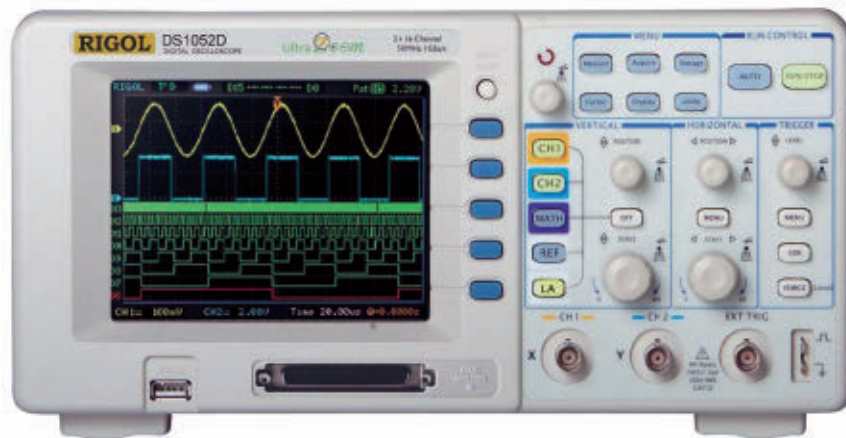

MSO scope.

statistics, reference waveform storage, and FFT capabilities are available on many oscilloscopes, allowing you to display modified signals or frequency spectra. Averaging helps to remove noise issues; digital persistence allows you to spot glitches more easily; math capabilities mean you can invert, add, subtract, multiply, divide, or scale channels; or even create your own functions.

Ease of Use

Some scopes offer “one-touch” automatic setup, or a number of memorized setup configurations, increasing a scope’s ease of use. Others include a built-in help system to save you constantly referring to the manual. Some scopes dispense with dedicated user-friendly rotary knobs, and replace them with cheaper buttons for often-used adjustments such as vertical sensitivity, time-base speed, trace position, and trigger level.

Downloading the scope’s manual from the vendor’s website will give you an indication of how intuitive it is to operate the oscilloscope while concentrating on your circuit under test. Finding an oscilloscope that is easy to use can save you a great deal of frustration later. Do you need remote control via LAN or USB?

Also, check if the scope’s software is upgradeable at no charge and easily available via an Internet connection. Finally, check the length of warranty. If your unit fails in use, will the vendor make repair an easy process?

MSO Ready

If you need to do digital debug too, a mixed-signal scope may be very handy. Some scopes now come with an MSO socket on the

front panel with eight or 16 digital channels so you can upgrade at a later date.

Built-in AWG

This is useful if you need a signal source for testing, or to do sweep tests for frequency response. Most AWGs supply common waveforms like sine wave, square waves, sawtooths, and pulses, but they

also come with PC software to allow you to create a custom waveform. A neat feature of some AWGs is the ability to take a captured scope input signal and reproduce it continuously.

Upgradeability

If you find you need other features at a later date when you either can afford or need them, check about upgrade capabilities. Many functions have software unlock keys so you can boost your scope’s functionality down the road, but some specs are hardware-driven and you need to make the right choice the first time!

Conclusion

There are economical scopes available now with capabilities that rival the big name manufacturers at well below \$1,000. Once you’ve chosen the form-factor, the selection priorities to consider are: value/money, bandwidth, sample rate (real time and/or equivalent time), and memory depth.

Note that bandwidth and sampling rate are not upgrade options on most DSOs, so once you’ve bought your product of choice you are stuck with your decision. “Hacking” upgrades are not recommended as they void a manufacturer’s warranty.

Everyone loves personal recommendations from trusted friends, but if you don’t know who to turn to, ask your friendly distributor, or check out YouTube for the many helpful reviews and “how-to’s.”

I hope this helps the next time you are looking to purchase test equipment. **NV**

Need a Scope?

Low Prices - Free Support - Excellent Customer Service



Alan Lowne, Saelig CEO, says: "Many questions arise when choosing a new digital oscilloscope. And it's a decision you don't want to regret! A first place to turn is often the plethora of reviews on YouTube – they can show you more details than just the specs. Google the product and search for videos. Then think about where will you use the scope (on the bench, at a customer's site, under the hood of a car.) How many signals do you need to measure at once? What are the maximum and minimum amplitudes of signals that you need to measure? What is the highest frequency of signal you need to measure? Are your signals repetitive or single shot? Do you need to view signals in the frequency domain (spectrum analysis) as well as the time domain? Cost is always a factor too. Memory depth – do you need to zoom in on small signal details? So look at these criteria..."

Form Factor – traditional bench-top, hand-held, or PC-based?

Bandwidth – for square-waves you'll need a scope with 5x higher bandwidth than the signal frequency.

Sample Rate – often depends on how many channels are in use.

Waveform Capture Rate – faster the better (defines the "dead space" of missed signals).

Memory Depth – a large memory will let you zoom in on small, fast, infrequent glitches.

Resolution and Accuracy – most scopes are 8-bit; 12-bit is great for seeing tiny signal changes

Triggering Capabilities – check if you need something special like triggering on digital waveform patterns

Input Ranges (& Probes) – typical scopes are +/-50mV to +/-50V

Connectivity – need remote access? USB data storage? WiFi access?

Built-in Capabilities – automatic measurements, pass/fail etc.

Ease of Use – "one-touch" automatic setup, memorized configurations, awkward multiple menu steps?

MSO Ready? – will you need simultaneous digital bus debugging as well as analog signal capture?

AWG? – a built-in signal generator saves space and is portable but may have limitations.

100 MHz Economy Oscilloscope Comparison Chart

	Siglent SDS1102CML	Owon SDS7102V	Rigol DS1102E	Siglent SDS1102X	Rigol DS1104ZPlus	Teledyne LeCroy WaveAce 1012	Siglent SHS810	PicoScope 3205D
Format	Benchtop	Benchtop	Benchtop	Benchtop	Benchtop	Benchtop	Handheld	PC-Based
Channels	2	2	2	2	4	2	2	2
Bandwidth	100 MHz	100 MHz	100 MHz	100 MHz	100 MHz	100 MHz	100 MHz	100 MHz
Max Sample Rate	1 Gsa/s	1 Gsa/s	1 Gsa/s	1 Gsa/s	1 Gsa/s	500 MSa/s	1 Gsa/s	1 Gsa/s
Waveform Capture Rate	60,000 wfm/s	40wfm/s	?	60,000 wfm/s	30,000 wfm/s	?	?	80,000 wfm/s
Memory	2Mpts	10Mpts	1Mpts	14Mpts	12Mpts	2Mpts	2Mpts	256Mpts
AWG?	Optional	No	No	Optional	Optional	No	No	Yes
MSO Ready?	No	No	No	Yes	Yes	No	No	No
Display Size	8" WVGA	8" WVGA	5.7" QVGA	8" WVGA	7" WVGA	7" WVGA	5.7" QVGA	N/A
Standard Triggers	Edge, Pulse Width, Slope, Video, Alt	Edge, Pulse Width, Slope, Video, Alt	Edge, pulse width, slope, video, pattern, continuous time, Alt	Edge, Pulse Width, Slope, Video, Pattern, Duration	Edge, Pulse Width, Slope, Video, Pattern, Duration	Edge, Pulse Width, Slope, Video, Alt	Edge, Pulse Width, Slope, Video, Alt	Edge, window, pulse width, window pulse width, dropout, window dropout, interval, logic, runt pulse
Serial Decode	Optional	No	No	Optional	Optional	No	Optional	Yes
Measurements	32	19	20	33	33	32	33	30
Battery?	No	Optional	No	No	No	No	Yes	No
Math Functions	A+B, A-B, Ax/B, A/B, FFT	A+B, A-B, Ax/B, A/B, FFT	A+B, A-B, Ax/B, FFT	A+B, A-B, Ax/B, A/B, FFT, integration, differentiation, square root	A+B, A-B, Ax/B, A/B, FFT, AND, OR, Not, XOR, Intg, Diff, Sqrt, Lg, Ln, Exp, Abs	A+B, A-B, Ax/B, A/B, FFT	A+B, A-B, Ax/B, A/B, FFT	-A, A+B, A-B, A*B, A/B, A*B, sqrt, exp, ln, log, abs, Norm, sign, sin, cos, tan, arcsin, arccos, arctan, sinh, cosh, tanh, derivative, integral, delay
Price	\$319.00	\$389.00	\$399.00	\$499.00	\$879.00	\$960.00	\$573.00	\$892.48

Economical scopes are now available with capabilities that rival the big name manufacturers at well below \$1,000. Note that bandwidth and sampling rate are not upgrade options on most DSOs, so once you've bought your product of choice you are stuck with your decision. "Hacking" upgrades are not recommended as they void a manufacturer's warranty! At Saelig Co. Inc. we have assembled the widest range of affordable scope solutions, from low-end USB scope adapters at under \$120, to sophisticated yet economical standalone scopes, to high-end 12-bit 2/4-channel mixed-signal scopes that cover 1GHz signals, as well as offering 8/16 channels of simultaneous logic analysis, and even up to the world's-fastest 12GHz sampling scope adapter. Details at <http://www.saelig.com/category/PS.htm>



For complete product details, visit us online!!

The Nuts & Volts **WEBSTORE**

GREAT FOR DIYers!

Raspberry Pi Electronics Projects for the Evil Genius

by Donald Norris

This fully illustrated TAB guide shows how to construct and program all kinds of fun and innovative gadgets with your Raspberry Pi. *Raspberry Pi Electronics Projects for the Evil Genius* features 10



complete projects that showcase cool RasPi applications in computing, communications, robotics, photography, and video. Each inexpensive project includes a detailed list of materials, sources for parts, schematics, and clear step-by-step assembly and programming instructions.

\$25.00

Electronics Workshop Companion for Hobbyists

by Stan Gibilisco

In this practical guide, electronics expert Stan Gibilisco shows you, step by step, how to set up a home workshop so you can invent, design, build, test, and repair electronic circuits and gadgets. *Electronics Workshop Companion for Hobbyists* provides tips for constructing your workbench and stocking it with the tools, components, and test equipment you'll need. Clear illustrations and interesting do-it-yourself experiments are included throughout this hands-on resource.

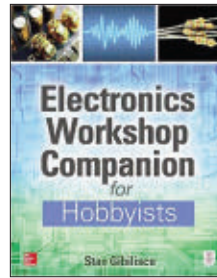

\$25.00

Arduino: A Beginner's Guide To Programming Electronics

by Chuck Hellebuyck

Arduino is one of the most popular microcontroller development boards available. It's more than just a module though, as the heart of Arduino is the software you run on your computer and use to create sketches (or programs) in the C programming language, with many pre-built functions. Chuck explains all this in very simple terms to help you get started programming your own electronic applications. His down-to-earth style of explaining technology makes it a great place to get started with programming electronics. **\$15.00**



Make Your Own PCBs with EAGLE

by Eric Kleinert

Featuring detailed illustrations and step-by-step instructions, *Make Your Own PCBs with EAGLE* leads you through the process of designing a schematic and transforming it into a PCB layout. You'll then move on to fabrication via the generation of standard Gerber files for submission to a PCB manufacturing service. This practical guide offers an accessible, logical way to learn EAGLE and start producing PCBs as quickly as possible.

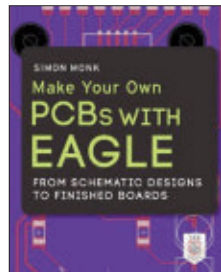

\$30.00

Programming the Intel Edison: Getting Started with Processing and Python

by Donald Norris

Learn To Easily Create Robotic, IoT, and Wearable Electronic Gadgets!

Discover how to set up components, connect your PC or Mac, build Python applications, and use USB, WiFi, and Bluetooth connections. Start-to-finish example projects include a motor controller, home temperature system, robotic car, and wearable hospital alert sensor.



\$20.00

Beginner's Guide to Reading Schematics, 3E

by Stan Gibilisco

Navigate the roadmaps of simple electronic circuits and complex systems with help from an experienced engineer. With all-new art and demo circuits you can build, this hands-on, illustrated guide explains how to understand and create high-precision electronics diagrams. Find out how to identify parts and connections, decipher element ratings, and apply diagram-based information in your own projects.

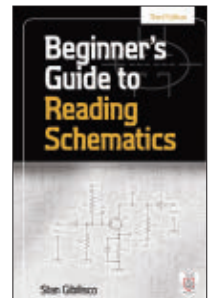

\$25.00

How to Diagnose and Fix Everything Electronic

by Michael Jay Geier

A Fully Revised Guide to Electronics

Repair all kinds of electrical products, from modern digital gadgets to analog antiques, with help from this updated book. The Second Edition offers expert insights, case studies, and step-by-step instruction from a lifelong electronics guru. Discover how to assemble your workbench, use the latest test equipment, zero in on and replace dead components, and handle reassembly. **\$24.95**

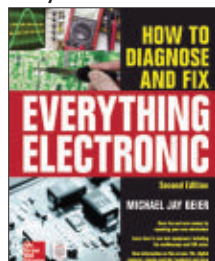

Programming PICs in Basic

by Chuck Hellebuyck

If you wanted to learn how to program microcontrollers, then you've found the right book! Microchip PIC microcontrollers are being designed into electronics throughout the world and none is more popular than the eight-pin version. Now the home hobbyist can create projects with these little microcontrollers using a low cost development tool called the CHIPAXE system and the Basic software language. Chuck Hellebuyck introduces how to use this development setup to build useful projects with an eight-pin PIC12F683 microcontroller. **\$14.95**



Programming Arduino Next Steps: Going Further with Sketches

by Simon Monk

In this practical guide, electronics guru Simon Monk takes you under the hood of Arduino and reveals professional programming secrets. Also shows you how to use interrupts, manage memory, program for the Internet, maximize serial communications, perform digital signal processing, and much more. All of the 75+ example sketches featured in the book are available for download. **\$20.00**



Order online @ store.nutsvolts.com
 Or CALL 1-800-783-4624 today!

EDUCATIONAL

Beginner's Guide Educational Combo!

Includes:

- Beginner's Guide to Embedded C Programming (3 books)
- VOL 2 Experiment Component Pack
- VOL 3 Experiment Component Pack

Price Reduced Now Only \$219.95

An Arduino Workshop

Are you puzzled about the Arduino but finding it difficult to get all the pieces in one place?

Joe Pardue
SmileyMicros.com

Puzzled by the Arduino?
 Based on *Nuts & Volts* Smiley's Workshop, this set gives you all the pieces you need!

Educational Combo \$124.95

We now have the fully updated Learning Labs 1, 2, & 3 in stock

Now \$45.95

Now \$47.50

Now \$41.95

Are you (or someone in your family) looking to get started in engineering, electronics, computers, or robotics? If so, this hands-on comprehensive Learning Lab series is for you! Each Lab includes hands-on exercises and training on practical electronics, components, and circuits. Complete details on all the Learning Labs are available in our webstore. Simply type "lab" into the search field at <http://store.nutsvolts.com>

Educator Discounts Available!

CD-ROM SPECIAL

Nuts & Volts 12 CD-ROMs & Hat Special!

That's 144 issues. Complete with supporting code and media files.

Free Shipping!

Only \$249.95 or \$24.95 each.

The Nuts & Volts Pocket Ref

All the info you need at your fingertips!

This great little book is a concise all-purpose reference featuring hundreds of tables, maps, formulas, constants & conversions. AND it still fits in your shirt pocket!

Only \$12.95

Visit store.nutsvolts.com or call (800) 783-4624

My First Near Space Payload to Need an FAA Waiver

Okay, how many readers remember vinyl LP records? (Wow, that many!) One place vinyl records haven't played is in near space. Well, now that's changed because of Third Man Records.

Preparing to Launch a Secret Payload

I received a phone call last April from David Jankowski. He explained how his organization SATINS (Students and Teachers in Near Space; <http://satinsprogram.com>) had been preparing a Third Man Records mission. Kevin Carrico designed the payload — the Icarus Craft — to play a vinyl record while handling the expected rigors of a near space flight. In July, David and Kevin brought the Icarus Craft to Idaho where they prepped it for launch in John Kernkamp's shop/lab, for which we all owe him a big thanks.

My work, on the other hand, revolved around two big issues and I began addressing them after David's phone call. They involved assembling a near spacecraft to carry the unique payload safely into near space, and finding out how to submit an FAA waiver for a balloon flight that didn't meet all the requirements for FAR 101 (Federal Aviation Regulation part 101).

A Big Balloon (Filled with Hydrogen)

The near spacecraft for this mission consisted of a neoprene weather balloon, recovery parachute, phonograph player, two tracking modules, and a BalloonSat science payload. To get the altitude we

desired meant the mission required a 3,000 gram weather balloon. A weather balloon that large needed a volume of hydrogen to lift five pounds more than the payload weight if it were to generate the desired ascent speed. That much gas and the special needs of the payload generated several concerns. I narrowed the concerns down to these five:

1. Would the balloon pull itself apart with the necessary initial gas load?
2. Could I ensure the load line (string connecting the balloon's nozzle to the parachute) would not snap in two and release the balloon prior to launch?
3. Would the balloon slip off the filling attachment during the filling process?
4. Would the balloon get away from us before we were ready to release it?
5. Would the balloon slip free of the load line during the ascent?

There's nothing anyone could do about the first concern. Thankfully, however, this turned out to be a non-issue because balloons distribute the stress of their buoyancy over their entire skin. I calculated that there was approximately two ounces of force per square foot of balloon surface once the balloon was filled with

hydrogen. That's milder than originally thought.

The second issue had an easy fix too: We'd double up the load line. Then, after doubling up the load line, we would tie knots in the doubled-over line every 12 inches. That's suppose to help distribute the load to both lines and at the same time give launch crews convenient places to grab the load line while raising the balloon. So, rather than wrap their hands (while wearing gloves) in load lines while raising the balloon, launch crews grabbed between the knots tied in the doubled-up load line.

I was concerned about the third issue because one of my balloons has slipped off the gas filler before. I was determined to prevent that from happening with this more expensive mission. Launch crews still taped the balloon nozzle to the filler as usual, but then tightened a hose clamp around the taped-over nozzle.

The duct tape protected the balloon's neoprene nozzle from cuts by the metal hose clamp, and the hose clamp increased the compression around the balloon's nozzle so that the balloon couldn't slip off the filler.

While lifting weight for long periods of time gets tiring, it becomes tiring much faster when you're holding down lift (pulling down works a whole different set of muscles than lifting up). To prevent fatigue from ending the mission before we could launch, we instituted

APPROACHING THE FINAL FRONTIER

Post comments on this article and find any associated files and/or downloads at www.nutsvolts.com/magazine/article/October2016_NearSpace-First-Vinyl-Record-in-Space.

a two-man rule that required two people to hold the balloon at all times. Every few minutes, we switched out the people holding down the balloon to give everyone a rest.

The fifth issue was only a problem on my first flight, but I wanted to make sure that history didn't repeat itself on this mission. In a normal near spacecraft, the load line ties to the balloon nozzle with a square knot, which we realize is not strong enough by itself. So, we also fold over the nozzle and then tape the knot and nozzle together with duct tape.

To strengthen the attachment between the balloon nozzle and load line even further, the launch crew added a hose clamp to the taped-up nozzle. Then, they taped the exposed metal band of the hose clamp to make sure it didn't find a way to scratch or pop the balloon.

It took over a month to work out all the details. However, by combining the solutions described above, we helped SATINS successfully assemble, launch, and recover the Third Man Records phonograph player.

Working with the Federal Aviation Administration (FAA)

One responsibility of the FAA is to keep air space safe for commercial use. This is why FAR 101 exists for balloon launchers like me. As long as a balloon launch meets certain FAR 101 requirements, then we can file a NOTAM and launch the weather balloon.

However, the flight for SATINS



The Third Man Records uniform for the launch of the first phonograph player into near space. Photograph by L. Paul Verhage.

and Third Man Records wouldn't meet these simple requirements. According to FAR 101, it needed two cutdown devices and two envelope termination devices. We were not prepared to incorporate these devices on the balloon flight, which meant contacting the FAA and learning how to apply for a waiver.

In short, I learned how to fill out an FAA 7711-2 Application for Certificate of Waiver. This is the same form that air show operators fill out.

After one submits the form, it takes the FAA a few weeks to review the request and pass it around to all interested parties for their approval. My FAA rep came back with the approval for the mission and a few requirements that we would need to fulfill during the flight, like calling our local ARTCC (Air Route Traffic Control Center) in Salt Lake City at regular times during the flight. I also shared with the FAA the website where they could track the flight online.

Ascent Rate
NearSys 16F

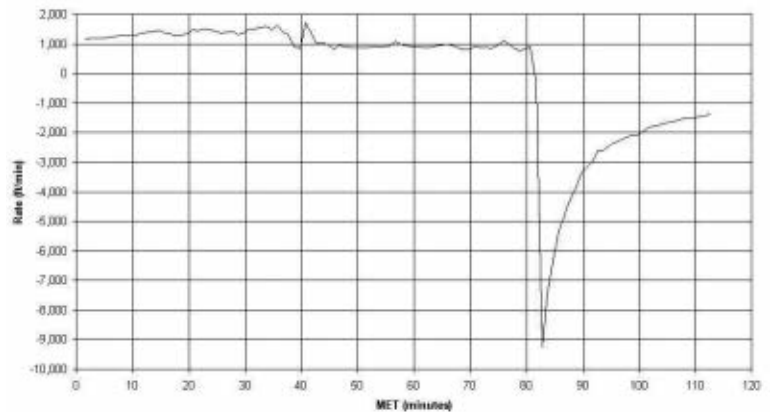

A graph of the ascent speed of the Third Man Records payload shows its peak ascent rate was nearly 1,600 feet per minute. After 45 minutes of flight, the increased size of the balloon and lower density of the air conspired to increase drag on the balloon and slow it down to its final descent speed. I created this chart from GPS data collected during the flight.

The Mission

The launch took place while Idaho was under a high pressure weather system. That's good news, as high pressure systems tend to generate weak and disorganized winds aloft. That typically results in launch conditions being calm on the surface and balloons flying short distances. So, all we had to do was find a launch site that was near a major road and that also put the recovery zone near a major road.

Finding launch and landing sites near major roads helps to keep balloon chases quick and efficient. We don't want to spend a long time driving down narrow twisty roads.

After a smooth launch, the chase crew drove south of Nampa, ID and parked their vehicles off the side of the road. There, we watched the balloon finish ascending to 94,413 feet. The balloon was visible to the chase crew as a star in the sky — if you knew where to look. Its burst and disappearance took several seconds to complete.

Because air density is so low at 94,000 feet, the payload initially

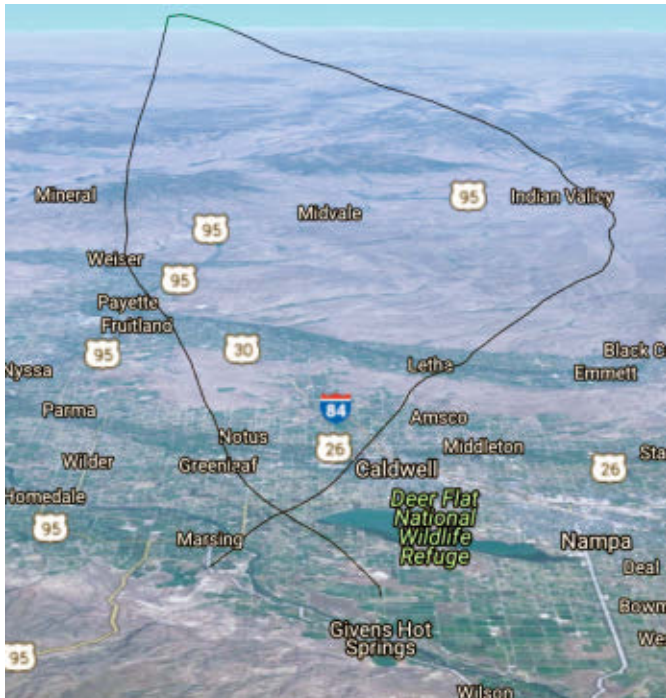

You'll notice that the winds aloft reversed directions during the flight. This is not very usual, but it is helpful. It keeps the chase crew from driving as far. I created this chart using Google Earth.

descended ten times faster at that altitude than its final landing speed. As the near spacecraft approached the



The happy recovery crew and myself. The rolling hills and dense vineyards made getting a position report over radio difficult until you got really close to the near spacecraft. Photograph by L. Paul Verhage.

ground, the denser air became more effective at slowing down the parachute. By the time it reached the ground, the near spacecraft touched down at a safe speed of 22.5 miles per hour. Flight tracking went well throughout the mission, and the chase crew was able to follow the balloon on their smartphones and the website, **APRS.fi**. The only tracking problem occurred during the last 1,000 feet of descent. The near spacecraft was both too close to the ground and too far away from amateur radio stations to send its final position to the chase crew or put on the Internet. This meant the chase crew received no position reports at the most critical part of the landing.

The chase crew drove around the landing zone until they got close enough to pick up a transmission directly from the near spacecraft. We ended up finding the near spacecraft lying between rows of grapes in a vineyard (did you know that portions of the Treasure Valley in southwest Idaho are wine region?).

Kevin and David were delighted to find the Icarus Craft relatively undamaged from its mission into near space. As you can read at Third Man Records (<http://thirdmanrecords.com>), the mission met its goal of playing "A Glorious Dawn" in near space. I was glad that my near space group was able to play a part in this mission.

Onwards and Upwards,
Your near space guide

NV

CLASSIFIEDS

ROBOTICS

Need sensors?

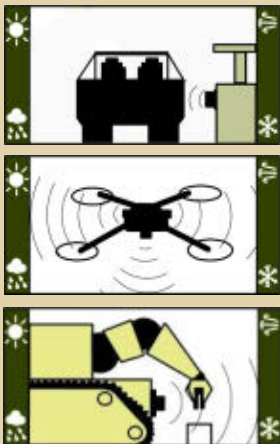

www.maxbotix.com

LIGHTING



HARDWARE WANTED

DEC EQUIPMENT WANTED!!!

Digital Equipment Corp. and compatibles.
Buy - Sell - Trade

CALL KEYWAYS 937-847-2300
or email buyer@keyways.com

PARTS EXPRESS

OVER 18,000
ELECTRONIC PARTS
IN STOCK



Speakers

Components

Project Accessories

Tools and Tech Aids

Save \$5 on \$75 order at
parts-express.com!

Promo code: NVOCT16
*Offer expires 12/31/16

parts-express.com
1-800-338-0531

PRESENTED BY BARNES & NOBLE

WORLD



NEW YORK
HALL OF SCIENCE

7TH ANNUAL

Maker Faire®

ny sci

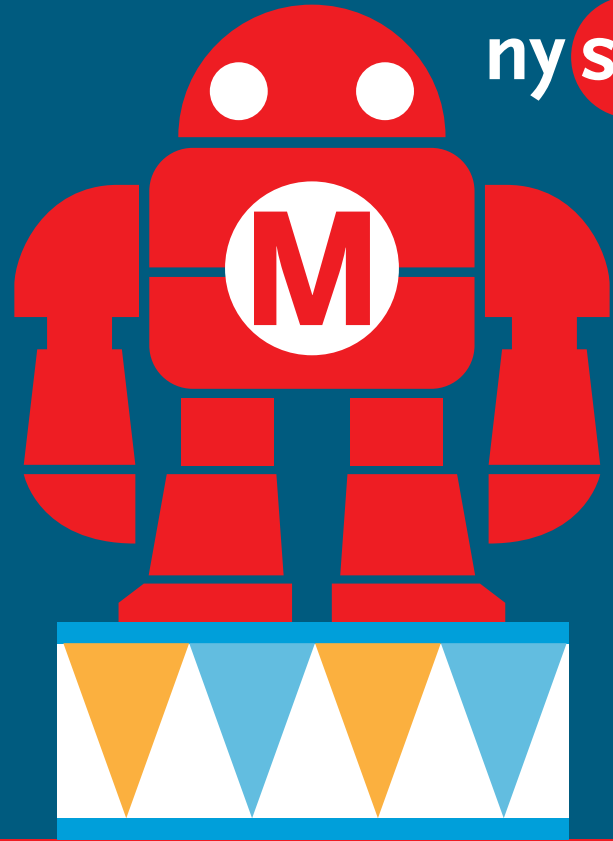

GREATEST
Show ★
& TELL
ON
★ *Earth*

OCT 1+2 NEW YORK HALL OF SCIENCE
FLUSHING MEADOWS, QUEENS, NY



PRESENTED BY

GOLDSMITH SPONSORS

SILVERSMITH SPONSORS



GET YOUR
TICKETS
TODAY!



makerfaire.com

BROUGHT TO YOU BY **Make:**

Resistor/Diode Tester

In my last article, I showed a 3D print for holding wires while you solder them (Figure 1). It works really well. Then, it occurred to me that the same design could be modified to become a resistor/diode tester when connected to an ohmmeter. This required some modification to the design, but that is easy when using the free online design tool called Tinkercad.

3D Design

The original wire holder design .stl file can be directly imported into Tinkercad. From there, I can add material or take it away with simple square, circular, or triangular shapes. Each shape can be resized and also turned into a “hole” element. A hole element is used to take away material where that shape intersects with the object being modified or built.

Figure 2 shows the finished design on the left and an X-ray version on the right that shows the internal

modifications. The first step was to use a block element as a hole to take away half of the slots for the wires. This left a single V-slot for the resistor or diode to drop into. Next, a cylinder shape was used to form a vertical hollow tube in the middle of the V-slots.

Each V-slot has a hollow tube. This is where a conductive terminal will be inserted to contact the leads of the resistor or diode. Another set of horizontal hollow tubes are then placed in the base of the unit at the front. These will have a set of female banana jacks installed. Another block element is used as a hole to take out a section underneath so I could have access to solder the terminals to the banana jacks. This completes the design changes, and then it can be printed.

MP Select Mini

Last time, I also showed you the Fabrikator Mini 3D printer, which fits nicely on your workbench. I want to introduce a new low cost (\$199) small 3D printer called the Select Mini (**Figure 3**). It's from **Monoprice.com** and has a 50% larger build area than the Fabrikator Mini, plus

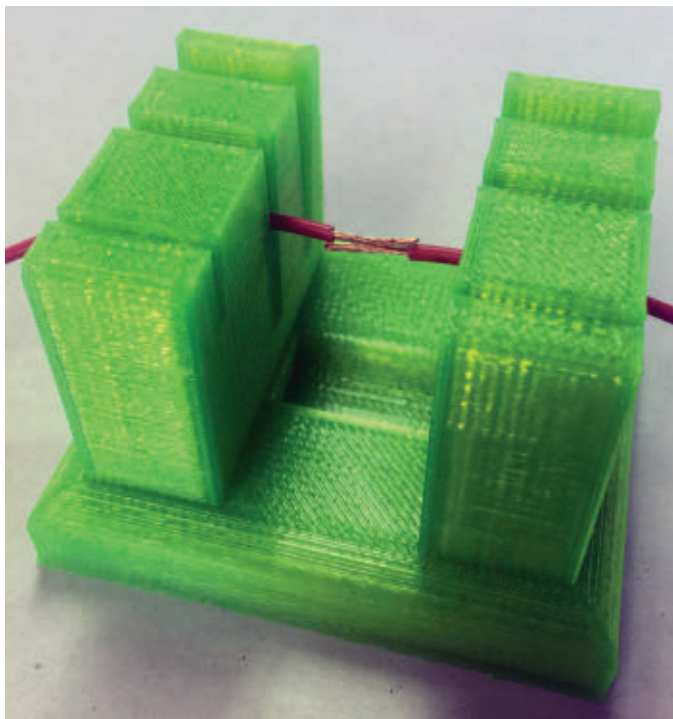

■ **FIGURE 1.** Wire holder 3D print.

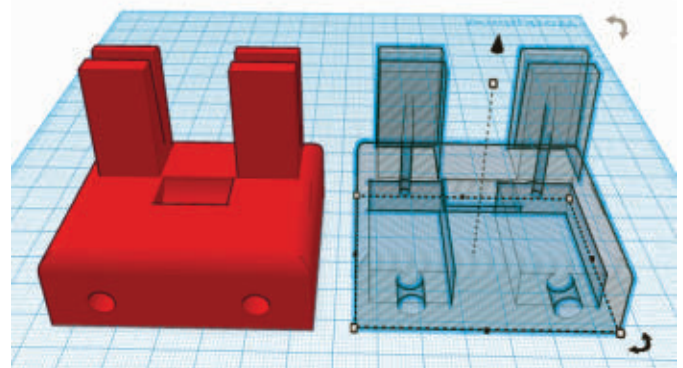

■ **FIGURE 2.** Wire holder in Tinkercad.

Post comments on this article and find any associated files and/or downloads at www.nutsvolts.com/magazine/article/October2016_Practical3DPrinting.

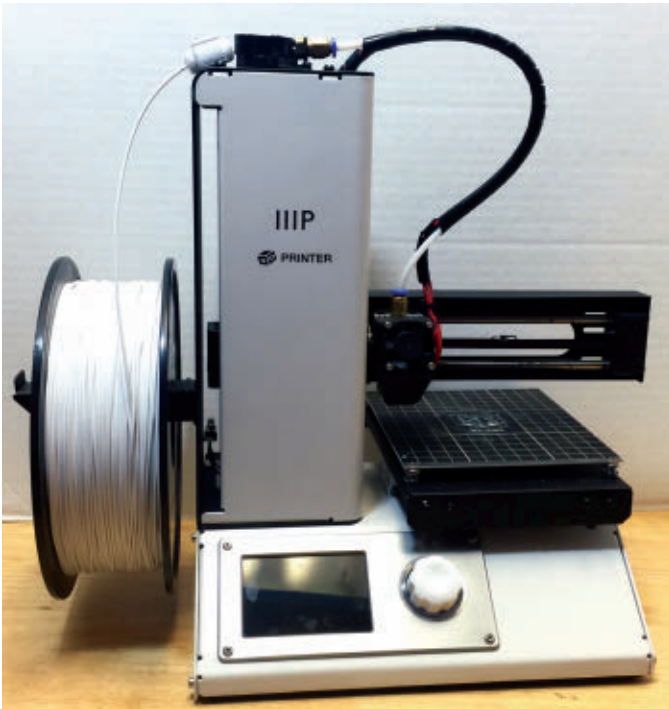

■ **FIGURE 3.** MP Select Mini 3D printer.

has a metal frame. The printer also has a heated bed for helping to make prints stick and includes an SD card and LCD control panel that I needed to add to my Fabrikator.

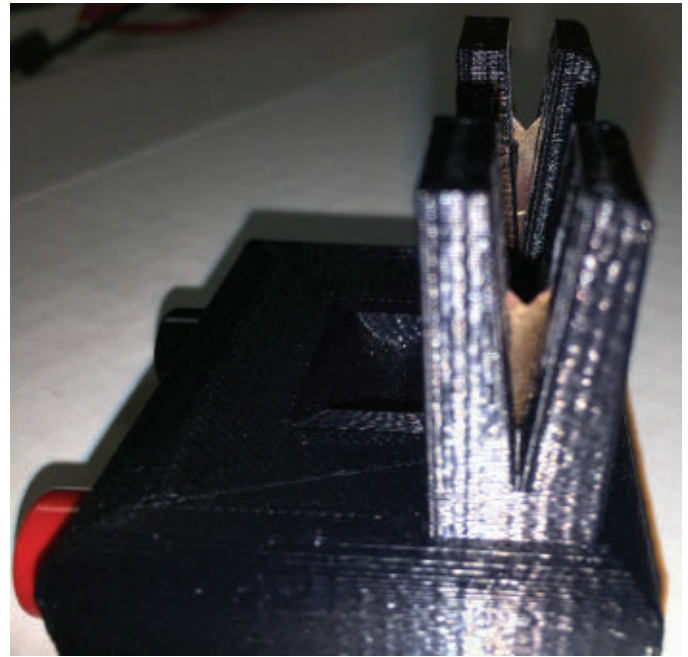

■ **FIGURE 5.** V-shaped conductors.

This is really a great printer for a beginner or for someone on a budget. It also is small enough to fit on your bench. The resistor/diode checker easily fits on the Select Mini bed, so it's a great addition to your electronics lab.

My 3D Print

I printed the design at a 0.2 layer height and 50% fill (which is the percentage of the inside that is solid plastic) because I wanted it strong. These are the settings that determine the quality of the print. Tinkercad software can export the .stl file, but it needs to be sliced and converted to G-Code for the 3D printer. This is where the layer height and fill percentage are adjusted. I use Simplify3D software

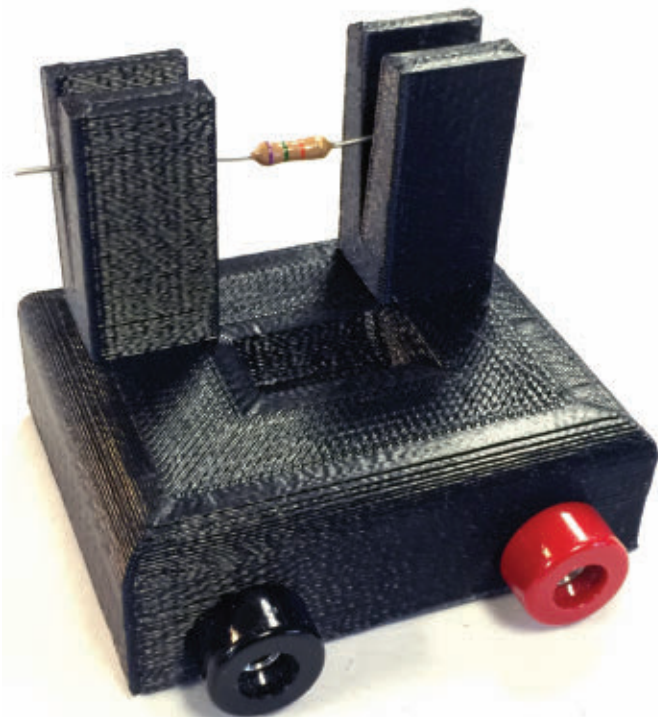

■ **FIGURE 4.** Finished design.

Resources

Check out my website and blog:
www.elproducts.com

My YouTube Channel:
www.filamentfriday.com

My 3D designs:
www.thingiverse.com/elproducts/designs

Tinkercad:
www.tinkercad.com

MP Select Mini:
Monoprice.com

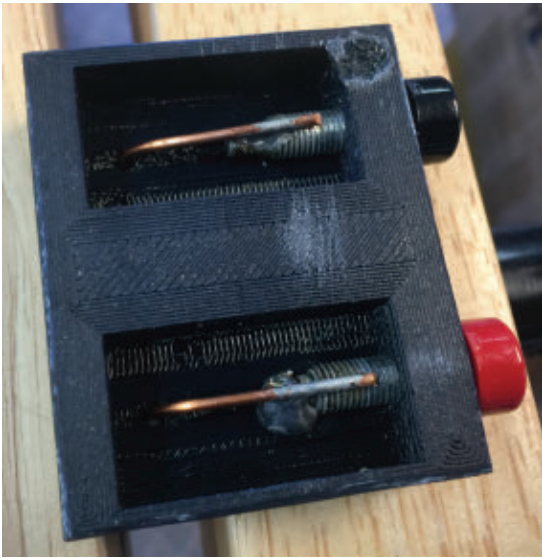

■ **FIGURE 6.** Bottom section soldered wires.



■ **FIGURE 7.** Testing a resistor.

the final design (**Figure 4**), but any color or plastic type available for a 3D printer will work. The 50% fill makes it a little heavier as well. The banana jacks and the internal wiring also make the unit heavier, but a piece of sticky back foam or even a sticky back sandpaper disk cut to size works great on the bottom to hold it in place on your bench.

Assembly

The 3D printer did the hard work of creating the base, so all that was needed was to add the electrical

to slice my prints. A slicer takes the .stl file and turns it into the X, Y, Z position G-Code that the printer understands. It's similar to Gerber files for creating circuit boards.

I used a black ABS plastic (same as LEGO blocks) for

connections. I used a 14 gauge household wire to make the conductors. I stripped off the insulation and then one end of the bare copper wire was flattened out with a hammer. I used a sheet metal notcher to cut a V-groove in

Three Days. Three Domains. Countless Opportunities.

UNMANNED SYSTEMS DEFENSE is an inclusive forum, bringing together industry, defense and government program managers, decision makers and technology experts for three intensive days of information sharing and networking. Each day is dedicated to a specific domain – maritime, air and ground – and includes panel discussions, in-depth presentations and networking opportunities.

REGISTER TODAY at thedefenseshow.org

UNMANNED SYSTEMS
DEFENSE
Powered by AUVSI

OCTOBER 25-27, 2016

The Ritz-Carlton, Pentagon City
Arlington, Virginia, USA

it. You can do the same with a file and a little more time.

The wire was then pulled through the holes in the middle of the V-grooves in the base and just the V-groove tip was heated with a lighter. Once hot enough to melt plastic, I pulled the wire through the hole in the plastic base V-slot until the Vs lined up (**Figure 5**). This was done on both sides to create the conductive pocket for the resistor or diode to rest.

The other end of the wire (not flattened) was bent at 90 degrees and then cut to length and soldered to the banana jacks (**Figure 6**). This connects the V-terminals so the ohmmeter can make an easy connection to the diode or resistor.

Testing

The fun part comes when you get to actually test your design to see if it works. I connected my ohmmeter to the base with a couple of test leads (**Figure 7**). I set the ohmmeter to auto range and then dropped in a few resistors and diodes to see if it worked. I found the smaller 1/8 watt resistors needed a little push to make a good connection, but the heavier 1/4 watt resistors and diodes seemed to make a connection most of the time without any pressure.

The tool actually works quite well. This is very helpful as my eyes are getting older and reading the color codes is getting tougher.

Figure 7 shows a 4.7K resistor being tested. This could also be used as an LED polarity tester if a series resistor and power supply are connected instead of an ohmmeter. I may modify this design for that in the future with a battery built into the base. That's the advantage to a 3D printed design; I can make many of them from the same file with the press of a button.

Summary

Hopefully, I showed that with a little effort and some creative thinking, you can easily create or modify a design to do what you want. That is what I like most about

3D printing; it can be used to make many different useful tools. I show a lot of my creations on my YouTube channel (**FilamentFriday.com**) that I create in Tinkercad and share the files on my Thingiverse account.

There is no end to what you can create and print on your 3D printer, even a smaller one like the MP Select Mini. The costs of 3D printing continue to get lower and the software tools are getting better. **NV**

ALL ELECTRONICS

www.allelectronics.com Order Toll Free 1-800-826-5432

10 WATT STEREO AMP MODULE

Crisp, clear stereo sound. Operates on 7-15Vdc. The audio source (ie. Cellphone, MP3 player) provides the volume control. Clearly marked solder spots for easy assembly. 25 x 30mm pc board.

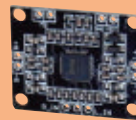

CAT# AMP-8610

\$7⁹⁵
each

GREAT PRICE! 2 GB MICRO-SD MEMORY

Kingston SD-CO2G 35.

CAT# MSD-2GB

\$2⁹⁵
each

10 for \$2.80 each
100 for \$2.50 each



COLOR HEAT SHRINK TUBING ASSORTMENT

154 pieces. Unbreakable clear plastic box with dividers contains 4 inch lengths of 6 different diameters:

- 1/16" - 56 pcs
- 3/32" - 35 pcs
- 1/8" - 28 pcs
- 3/16" - 18 pcs
- 1/4" - 9 pcs
- 3/8" - 8 pcs



CAT# HS-4900

\$11⁹⁵
each

LED MOTION SENSOR LIGHT

Turns on when it senses movement and turns off after 90 seconds. 3.25" x 2.03" diameter. Uses three AAA batteries (not included).

CAT# MSL-04

\$5⁹⁵
each



2" MINI-HOOK JUMPERS

Five 18" long mini-hook patch cords. Black, red, white, green and yellow.

CAT# MTC-5

\$6⁹⁵
5-pack



2-CONDUCTOR LOCKING CONNECTORS W/ LEADS

Pins on 2.5mm centers. Black nylon housing with release on male side of connector. Female side can be snap-mounted into a chassis. 12" color-coded leads, 22 AWG stranded wire.

CAT# CON-240

\$1³⁵
each

10 for \$1.20 each
100 for 95¢ each



DADY HEADPHONES

Originally marketed as headphones for kids, they rest comfortably on an adult-sized ear as well. Adjustable headband and an inline volume control. 3.5mm stereo plug. Surprisingly good quality.

CAT# HP-109

\$8⁹⁵
each

16 for \$8.70 each

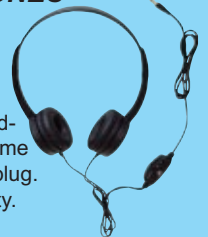

EXTRA-LOUD MINI PIEZO SIREN

Small, painfully-loud two-tone piezo siren for auto or home security devices. Operates 6-12 vdc, 110 ma. 108dB output.

CAT# ES-10

10 for \$4.00 each

\$4⁵⁰
each



Get Up and Running Quickly with Bluetooth Low Energy (BLE)

Here lately, Microchip is swallowing up companies right and left. One of those acquisitions was a company called ISSC Technologies. If you take a look at the ISSC page on Microchip's website, you will immediately conclude that ISSC is a Bluetooth oriented venture. Although the company name ISSC can still be found within some of the Microchip documentation, the ISSC product line has been absorbed into the Microchip fold. This month, we will examine an ISSC Bluetooth Low Energy product that is now known as the Microchip BM70.

Updating Our BM70

Before we start exploring the BM70, we must make sure that our firmware is at the latest level. The

BM70 radio module that is riding the BM70 PICtail Plus you see in **Photo 1** arrived with down-level firmware. As of right now, the latest BM70 firmware version is 1.06.

A word of caution is necessary at this point. Be sure to download the tools and update firmware image from the Microchip Developer Help wikidot pages. The firmware and user guides that are available via web searches are down-level. For instance, the 0.29 version of the BLEDK3 Manual Test Tool is all you can get from the web. The latest version of

the BLEDK3 test tool is 0.37, which can be downloaded from the links on the wikidot pages. To access the Microchip wikidot pages, search the web using the keywords "Microchip Developer Help."

The names of the BM70 toolset and user guides include the word "BLEDK3." BLEDK3 and BM70 mean the same thing. The latest version of the BLEDK3 User Interface Configuration Tool is displayed in the banner area of **Screenshot 1**. We will use this tool to update our BM70 (BLEDK3) firmware. Once the firmware update is complete, we can use the BLEDK3 User Interface Configuration Tool to set up our BM70 connections and data transfer parameters.

The BM70 update procedure requires that an image of the firmware be accessible to the BLEDK3 configuration tool. The files that make up the 1.06 firmware image are shown in **Screenshot 2**. Take another look at **Screenshot 1**. Note that only the LOAD and UPDATE buttons are active. We will use the LOAD button to pull in saved BLE parameters when we configure our BM70. Right now, we are interested only in updating our BM70 firmware. So, we will click the

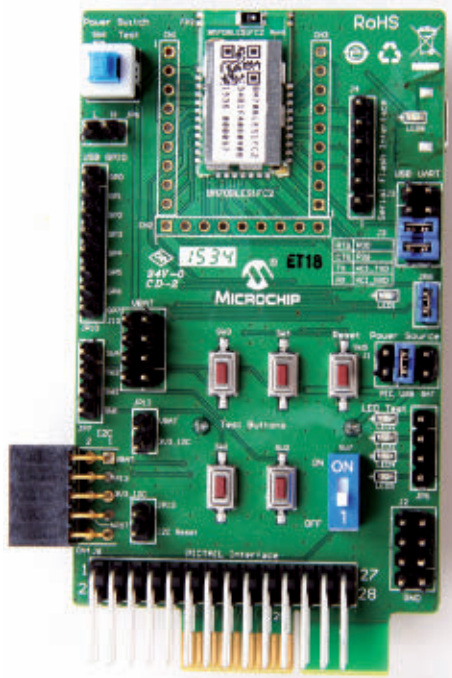

■ **PHOTO 1.** The BM70 PICtail Plus is a ready-to-roll BM70 evaluation platform. The PICtail Plus can stand alone, be attached to an Explorer development board, or interfaced to an external microcontroller.

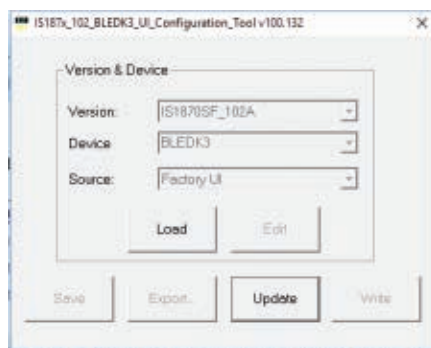

■ **SCREENSHOT 1.** The BLEDK3 UI Configuration Tool can be used to update the BM70 firmware and set up the BM70 connection and data transfer parameters.

Post comments on this article and find any associated files and/or downloads at www.nutsvolts.com/magazine/article/October2016_DesignCycle.

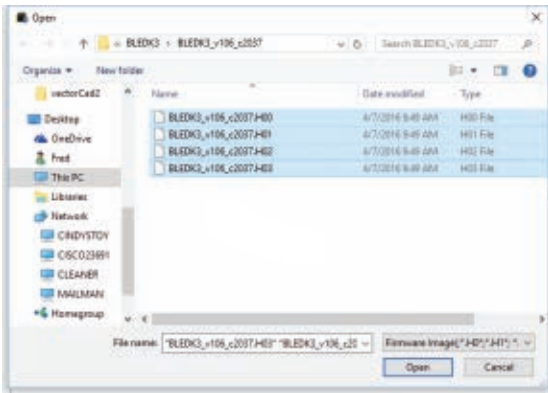

■ **SCREENSHOT 2.** These files were downloaded from links on the BM70 Microchip Developer Help page. You can immediately identify these files as version 1.06 from their file names.

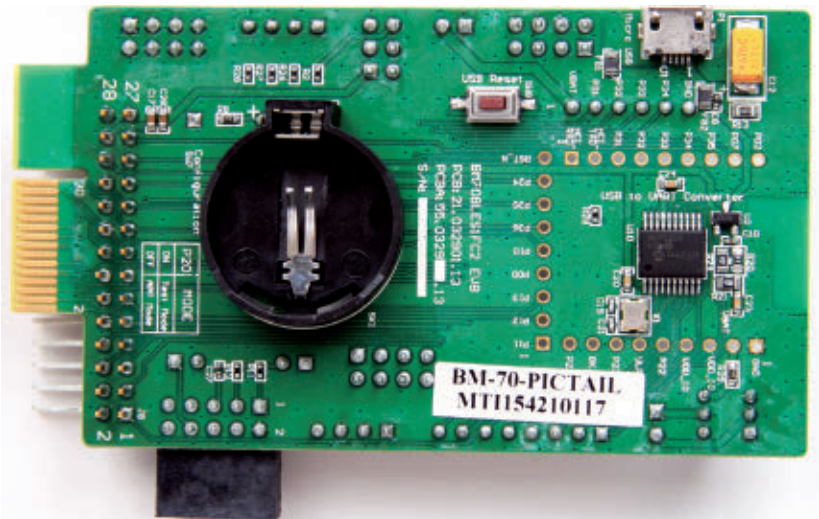

■ **PHOTO 2.** Yep. The BM70 can be powered with a simple coin cell.

UPDATE button.

Photo 2 is a rear view of the BM70 PICtail Plus. The lone IC is a Microchip MCP2200 USB-to-UART converter. For now, the only way we can communicate with the BM70 radio module is via its UART pins. The BM70 is also capable of speaking I²C and SPI.

Currently, there is no support for I²C and SPI in the version 1.06 firmware. **Screenshot 3** shows us connected to the PICtail Plus via my PC's COM4 serial interface. **Screenshot 3** also reveals the quartet of 1.06 firmware image files that we will push up to our down-level BM70 radio module. According to **Screenshot 4**, our BM70 firmware update required 18.357 seconds.

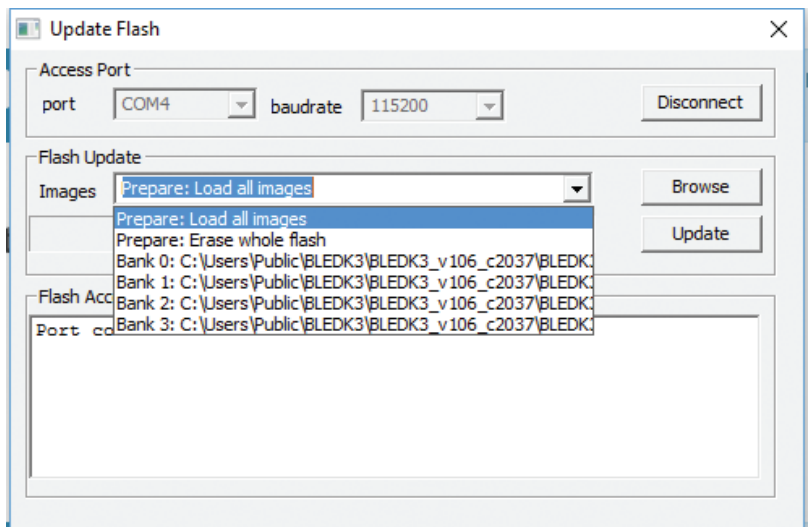

■ **SCREENSHOT 3.** Updating the BM70 firmware is a no-brainer. Fire up the BLEDK3 UI Configuration Tool, click the UPDATE button, connect to the BM70, browse for the firmware files, load the selected files, and smack the UPDATE button.

First Contact

We are going to use the BLEDK3 configuration tool to configure our BM70 as a peripheral device. The other end of our BLE (Bluetooth Low Energy) link is an iPad which is acting in the BLE central role. Once we have our BLE configuration in place, we will use the Manual Pattern Test Tool to control the operation of our newly configured BM70. This tool enables us to issue commands and view command results using a PC.

The first order of business is to place the BM70 PICtail

■ **SCREENSHOT 4.** In less than 20 seconds, our BM70 is loaded with the latest and greatest firmware version. From here on out, we will use the BLEDK3 UI Configuration Tool to configure our updated BM70 radio module.

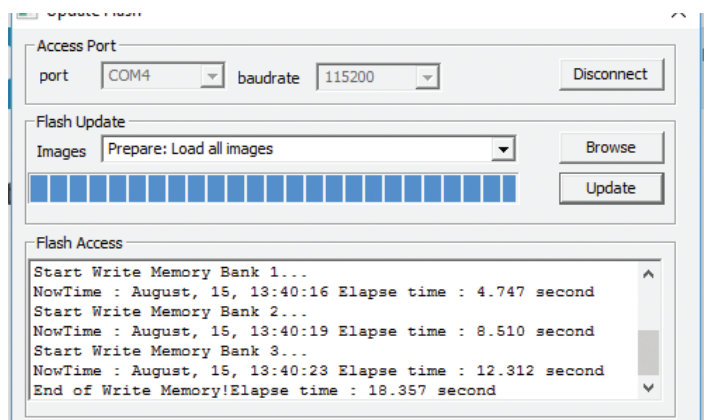

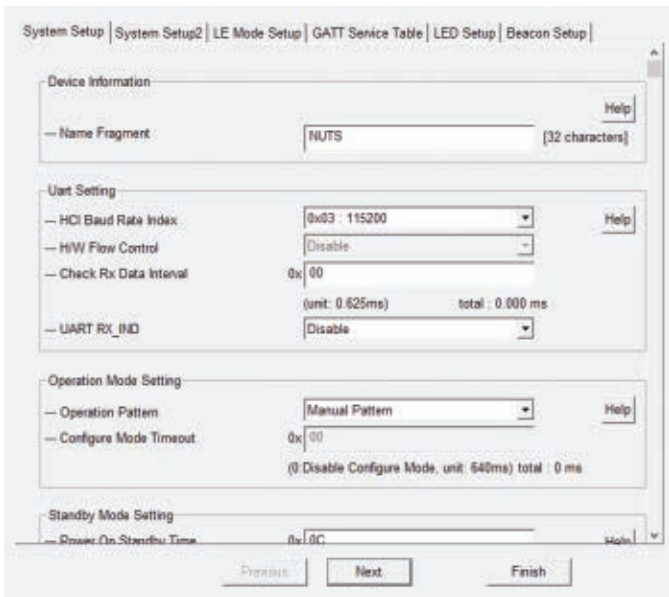

■ **SCREENSHOT 5.** There are lots of buttons and switches on this page. However, we are only interested in a few of them. Only the Name Fragment, UART RX_IND, and Operation Pattern entries have been modified.

Plus into Test Mode. This is easily accomplished by placing the single-position DIP switch in the ON position. The blue DIP switch stands out in **Photo 1**.

The contents of **Screenshot 1** are presented to us once again following the invocation of the BLEDK3 user interface configuration tool. Instead of clicking on the



■ **SCREENSHOT 7.** Our BLE central (iPad) will scan the Ether looking for BLE peripheral advertisements. Once a BLE advertisement is received, it is up to the BLE central to initiate the connection.

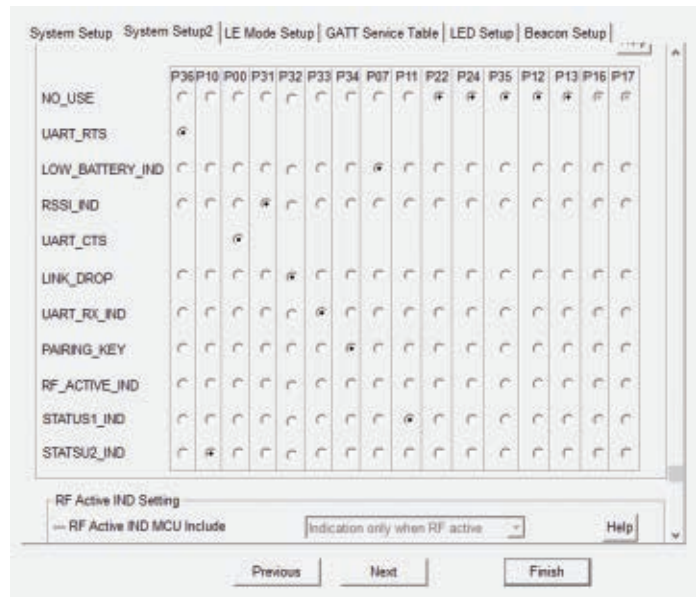

■ **SCREENSHOT 6.** This capture lays out the control and indication GPIO pin assignments. We can ignore these settings for now as they don't have anything to do with us getting our BM70 on the air.

UPDATE button, this time we will choose the LOAD button. Since this is our first BM70 rodeo, we will load a default BM70 configuration file called *S1870SF_102_BLEDK3_UI v100.132(BM70) default*. The EDIT button becomes active with the loading of the configuration file. A couple of intuitive clicks later, we find ourselves facing the first setup window which I've captured in **Screenshot 5**.

There are a multitude of knobs we can twist on this page. However, we are only going to modify the Name Fragment, UART RX_IND, and Operation Pattern fields. Disabling the UART RX_IND function prevents the BM70 from turning off its receiver in low power mode. The Operation Pattern field was changed from Auto Pattern to Manual Pattern. Auto Pattern operation deals with the transparent UART data transfer service of the BM70. Manual Pattern operation allows the BM70 to operate as a generic BLE link controller governed by GATT specifications.

BLE GATT (Generic Attribute Profile) defines the way data is transferred between BLE devices, while BLE GAP (Generic Access Profile) deals with advertising and connections. What was done to the Name Fragment field is obvious to the most casual observer.

Screenshot 6 is focused on configuring the BM70's GPIO. What you see are default control and indication settings. At this moment in time, all we are interested in is the PICtail Plus' blue module status LED, which is by default connected to the BM70's GPIO pin P0_2.

Before our BM70 BLE module can connect to the iPad, it must advertise its presence. The data entered

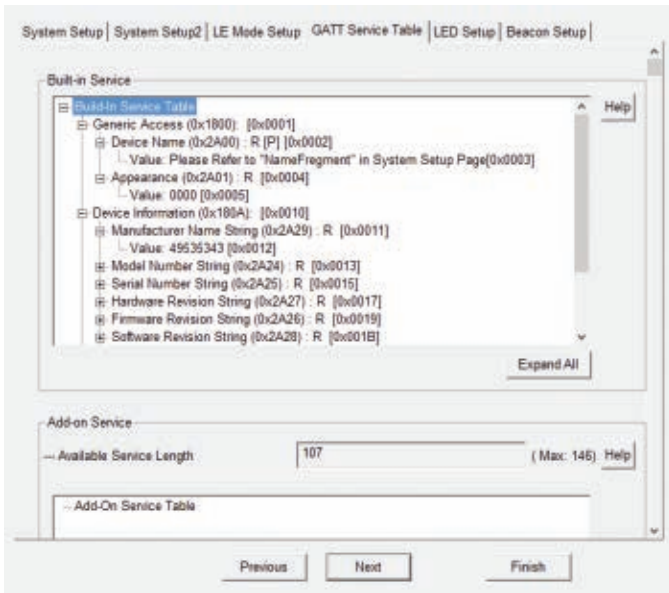

■ **SCREENSHOT 8.** This is a glimpse of how the data is manipulated in the BLE world. It all revolves around Profiles, Services, and Characteristics.

in the **Screenshot 7** window is included in our BM70 advertisement. For ease of recognition, I've added some Manufacturing Data to our advertisement in the form of 0xDEADBEEF. Thus, our advertisement packet will include the device name (NUTS), our manufacturing data (0xDEADBEEF), and the flag (0x06) data.

The BM70 has some native BLE services which are shown in **Screenshot 8**. Don't get too excited about these yet. However, when we make a connection, you will see these services along with their characteristics in the services discovery window of the iPad application. As you get deeper into BLE lingo, you will come across the terms Profile, Service, and Characteristic. A profile is a collection of services. Each service houses characteristics. The data is encoded within the characteristics. There are predefined profiles and services.

For instance, in **Screenshot 8** the Generic Access service is assigned the number 0x1800. Every time you see service 0x1800, it refers to the Generic Access service. The Generic Access service contains two mandatory characteristics which are Device Name and Appearance. Both the Device Name and Appearance characteristics must have Read properties. That's represented by the "R" you see in multiple instances inside the data window of **Screenshot 8**.

The Device Name characteristic contains a value of "NUTS" which happens to be our desired device name. The Appearance characteristic value is set at 0x0000, which translates to



■ **SCREENSHOT 9.** These timing values determine how the blue status LED blinks when advertising and when connected.

unknown. Note that the Device Name and Appearance characteristics are also assigned unique identification numbers. Get used to it because that's the way it is in the BLE world.

Recall that the blue status LED is a permanent member of the PICTail Plus family. The timing values you see in **Screenshot 9** determine how the status LED blinks when advertising (Standby) and when the BM70 is connected.

At this point, we should have enough information entered to transmit advertisements and accept connections. So, let's open up the BLEDK3 Manual Test

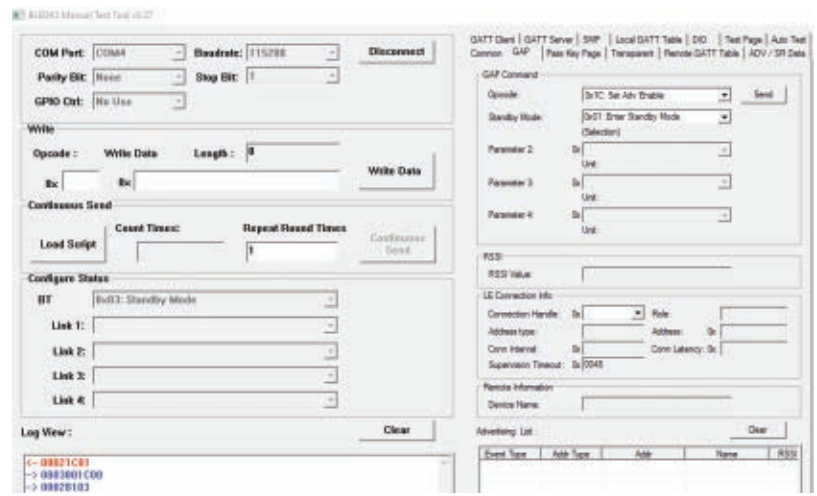

■ **SCREENSHOT 10.** Recall that GAP (Generic Access Profile) has to do with advertisements and connections. So, it's logical to enable the transmission of the advertisements under the GAP tab.

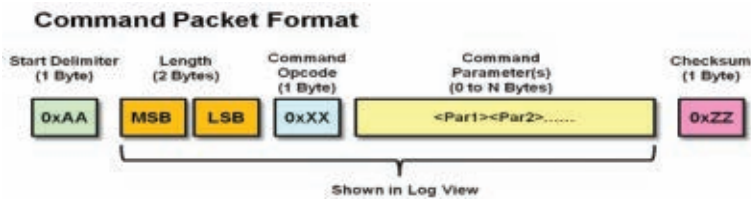

■ **FIGURE 1.** The Start Delimiter and Checksum bytes are not displayed in the Log View. However, using this figure and the contents of Screenshot 10 make it easy to decipher the Enter Standby mode command byte order (0x00021C01).

■ **FIGURE 2.** You can easily pick out the fields of the BM70 responses, which are blue in color within the Log View window. The hex string 0x0003801C00 indicates a successful execution of the previous command. Standby Mode status is signaled by the hex string 0x00028103.

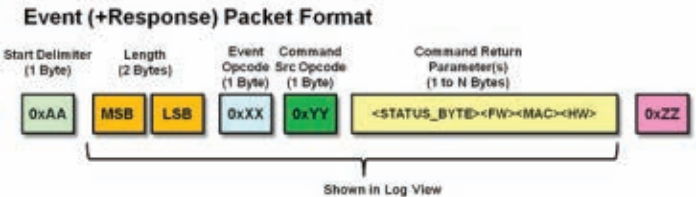

Tool and drop the hammer. In **Screenshot 10** under the GAP tab, we enabled advertising by commanding the BM70 into Standby Mode. The Log View window shows the Enter Standby Mode command going out (0x00021C01). The following incoming packet tells us that the command was successfully executed (0x0003801C00). The last incoming message gives us the current status of the BM70, which is Standby Mode (0x00028103). The outgoing command packet breakdown is illustrated in **Figure 1**. The incoming command response packet

```

Bluetooth Low Energy Link Layer
  Access Address: 0x8e59bed6
  Packet Header: 0x1500 (PDU Type: ADV_IND, TxAdd=False, RxAdd=False)
  Advertising Address: sstaiwa_06:09:0b (34:81:f4:06:09:0b)
  Advertising Data
    Device Name: NUTS
      Length: 5
      Type: Device Name (0x09)
      Device Name: NUTS
    Manufacturer specific
      Length: 5
      Type: Manufacturer Specific (0xff)
      Company ID: unknown (0xadfa)
      Data: beef
    Flags
      Length: 2
      Type: Flags (0x01)
      000. .... = Reserved: 0x00
      ...0 .... = Simultaneous LE and BR/EDR to same device capable (host): false (0x00)
      ...0... = Simultaneous LE and BR/EDR to same device capable (controller): false (0x00)
      ...1... = BR/EDR not supported: true (0x01)
      ...1... = LE general discoverable mode: true (0x01)
      ...0... = LE limited discoverable mode: false (0x00)
  CRC: 0x7f0ee4
0000 0a 06 28 01 06 13 06 0a 01 25 31 00 00 57 0f 00 ..(.....)S3..MD
0010 0a 06 28 01 06 13 06 0a 01 25 31 00 00 57 0f 00 ..(.....)S3..MD

```

■ **SCREENSHOT 11.** The hardware used to interface to Wireshark is an Adafruit Bluefruit LE Sniffer. The LE Sniffer is based on the Nordic nRF51822.

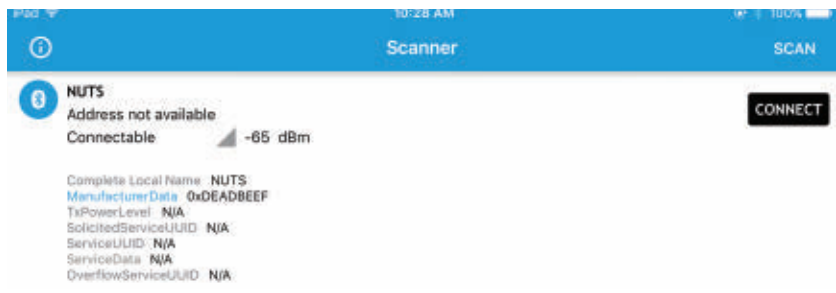

■ **SCREENSHOT 12.** This is a pre-connection view of the BM70 advertisement provided by Nordic's nRF Connect app. It doesn't tell us much as we didn't give our BM70 much to tell.

structure can be seen in **Figure 2**. Everything is ducky according to the BLEDK3 manual test tool. If there are advertisements flying about, we should be able to catch them with Wireshark. The Wireshark capture you see in **Screenshot 11** comes to you courtesy of the Nordic nRF Sniffer firmware and Adafruit's LE Sniffer hardware. It's all there in the capture. You should be able to easily find the device name (NUTS), the manufacturing data (0xDEADBEEF), and the flag breakdown.

Another view of the advertisement data can be seen in **Screenshot 12**. This view is presented by the nRF Connect app. We are just one tap away from a connection here. So, the finger falls and **Screenshot 13** appears. Again, you can easily relate the information you see in **Screenshot 13** to the advertisement information we entered, and the Built-in Service window displayed in **Screenshot 8**.

All This Work and No Data??

That's right. All of the work we've done so far was to simply get a pair of BLE devices connected to each other. The BLE peripheral application to transfer data between a central (tablet, smartphone, etc.) and a peripheral (PICtail Plus) exists in the host microcontroller. Even though the BM70 can perform GPIO tasks, generate PWM signals, and measure voltages using its onboard ADC (analog-to-digital converter), in the end the BM70 depends on an external

BM70
BM70 PICtail Plus
BLEDK3 Programming Tools
Microchip
www.microchip.com

Bluefruit LE Sniffer
Adafruit
www.adafruit.com

nRF Connect
nRF Sniffer
Nordic Semiconductor
www.nordicsemi.com



■ **SCREENSHOT 13.** You can relate much of this data to the BM70 built-in service layout in Screenshot 8.

Host Controller to issue application commands. In the case of the BM70 PICtail Plus, the Host Controller Interface (HCI) consists of the BM70's HCI TX and HCI RX pins.

I did not post a schematic for the PICtail Plus as it is part of the BM70 PICtail Plus Evaluation Board User's Guide. When you download your copy of the EVB Guide, you will see that the BM70 is unencumbered. None of the peripheral LEDs, pushbutton switches, or serial communication devices are tied directly to any of the BM70's pins. Instead, all of the peripheral devices are pinned out to headers on the PICtail Plus. These headers are universal to any of the Microchip development boards that support PICtail. That means you can plug the PICtail Plus into an eight-bit development board as easily as you can plug it into an Explorer 16 development board.

The BLEDK3 Tools mask much of the complexity involved in programming the BM70. However, all of the real world GATT and GAP stuff that makes BLE work is available via the BLEDK3 manual test tool. The test tool's Log View can be used to generate command sequences that can be copied into your microcontroller application.

The Bottom Line on BLE

For a bit less than \$90, you can have a BM70 PICtail Plus of your own. The programming tools are free, and for another \$30 you can purchase an Adafruit dongle that will allow you to sniff your BLE packets with Wireshark. The BM70 PICtail Plus is just one more way to add BLE to your Design Cycle. **NV**

RF Specialists

"Making your RF ideas into profitable products."

MURS

(Multi-Use Radio Service)



Wireless A40

Portable Wireless Alarm System • Door Alarms • Fence Alarms
Temperature Fire Alarm • Medical Alarm in Hospital/Home Care
Classroom Emergency Alarms • Multi Building Alarms

RF Design Services

Prepared to work with your in-house engineers, or support
your RF project from initial design to implementation.
Industrial • Military • Space • Medical • Smart Grid Metering • SCADA • Lighting Control



LE MOS



INTERNATIONAL

Tel: 1.866.345.3667
orders@lemosint.com
www.lemosint.com

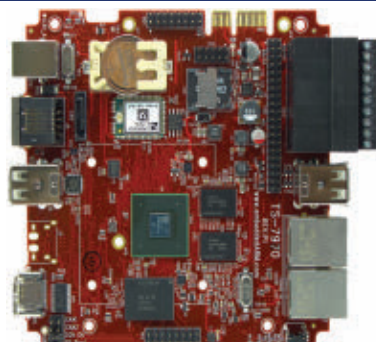

Technologic Systems



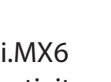



TS-7970

Industrial High Performance i.MX6
Computer with Wireless Connectivity
and Dual GbEth

- 1 GHz Single or Quad Core Cortex A9 ARM CPU
- 2 GB DDR3 RAM (Quad) and 4 GB MLC eMMC Flash
- Bluetooth 4.0+EDR and WiFi 802.11BGN onboard radios

\$169
QTY 100

www.embeddedARM.com

>>> QUESTIONS

Fan Conversion

My desk fan has a three-position switch: HI/OFF/LOW. I would like to convert the fan to variable speed. Will a simple lamp dimmer work for this purpose? If so, what winding of the motor do I connect it to? High or low?

#10161

Michael Walczak
St Helens, OR

Fish Caller Circuit

I found a partially assembled kit labeled "Fish Caller." Does anyone have a schematic for one that I could use to finish it? Also, what's the theory behind how it works ... or does it?

#10162

Carl Kaminski
La Porte, IN

Surface-Mount Oven Controller

I'd like to dive into doing surface-mount projects. I've heard of people using a regular toaster oven for soldering. Will an off-the-shelf oven work or is a special temperature controller required for a satisfactory result? Or, would I be better off just soldering by hand to start?

#10163

Michael Yon
Farmingdale, NY

iPod Charge Dilemma

I have an Apple iPod and lost the little USB charge brick. I have a USB charger that works with my cell phone but it won't charge the iPod. Is there something "special" about the Apple iPod charger and if so, can I modify a "regular" charger to work with both?

#10164

Brandon Barajas
Clarion, PA

Arcade Game Restoration

I'm refurbishing a vintage video arcade game. There is a transformer

between the video monitor and the mains power but it measures as open. From the schematic, it seems to be a simple 115 VAC 1:1 isolation transformer. Is an isolation transformer necessary when the entire cabinet is wood, or is it overkill? It would seem that the wood cabinet would be enough protection to prevent contact by a user with the AC.

#10165

Thomas Greer
Augusta, GA

>>> ANSWERS

[#6163 - June 2016]

Cats In The Crystal

I inherited an antique "cat's whisker" crystal radio set. Everything seems to be intact except the actual crystal that the cat's whisker touches. Any ideas on where I can find a replacement crystal?

You need what is known as a Galena crystal. You can find these on eBay, Etsy, and similar websites. I found several listings under \$10. If you need the entire detector including the stand and adjustable wire, google "cat's whisker detector."

These detectors were in use at the very beginning of the last century, before vacuum tube detectors were available. They create a semiconductor diode, using a fine wire (the "whisker") just touching the Galena crystal. Getting them to work was and is something of a black art because not all areas of the crystal will act as a diode when touched by the wire, and they are sensitive to pressure, movement, and vibration.

If you want to play with the radio receiver without having to adjust the crystal every time, you can replace it with a 1N34A germanium detector diode. These are available on eBay and also at any electronic component

distributor for a couple of dollars.

Mark Lewus
Denville, NJ

[#7161 - July 2016]

Vintage Fuzz

My vintage JAX "fuzz" guitar pedal seems to be dead. I've put a new battery in it but it doesn't pass sound at all – even when I press the bypass switch.

#1 I would start by replacing all the 10 μ F electrolytic capacitors (the gray components standing up with two leads exiting the bottom). Electrolytic capacitors age, and in the absence of electric charge can eventually short or develop a high internal resistance. Perhaps only one is defective, but likely all are marginal and others might fail in the future. It's easier and cheaper to replace them all than to attempt using an ohmmeter to determine which are good and bad. Jameco P/N 29891 is a suitable replacement part that costs \$0.15 each (\$1.80 for the 12 you'll need). RadioShack has a suitable part also (2721025), but its price is \$1.49 each. Use caution removing and soldering in the new parts. The old single-sided PCBs have copper traces that delaminate easily with heat.

Bob Stewart
Mancos, CO

#2 Most of those old pedals, and even the new ones, used the case as ground. If the jack nut is not tight or if there is corrosion on the jacks, they will not work right. The first thing I check when I get one of these in is the jack nut. That usually fixes the problem.

Thomas McCraig
Virginia Beach, VA

#3 Assuming you have proved you have an output from the guitar, also the amplifier and both cables

Send all questions and answers by email to forum@nutsvolts.com
or via the online form at www.nutsvolts.com/tech-forum

are okay, the fault must be either the FUZZ boxes bypass switch is faulty or a break in the internal wiring between the switch and one or both 1/4" jack sockets.

A quick continuity test with a meter will prove where the fault is.

John Swift
via email

[#7162 - July 2016]
Speaker Phase

How do I test/tell the phase of my speakers so I know I am installing the leads correctly?

#1 Proper polarity is when all the cones of the speakers move in the same direction when the same polarity DC voltage is applied to two or more speakers. Stereo speaker terminals are usually marked red(+) and black(-), so you just need to keep them mated to the amplifier's terminal markings. If there are no marked terminals or you just want to verify the polarity, it is easy. If you can see the speaker cone, connect a 1.5V battery to the speaker wires so that the cone moves outward when the battery is applied, reversing the battery if the cone moves inward. When the cone moves outward, the positive side of the battery is the red (+) speaker lead, and the negative is the black(-) lead.

Another method is to connect the speakers to a monaural audio system and have it play a male voice speaking. When you are centered in front of the speakers, the voice will appear to be coming from between the speakers when the polarity is correct. This works on a stereo system by selecting the MONO mode.

In any case, if the polarity is incorrect, just reverse the wires at one speaker, or one speaker output at the amplifier. This is most important whenever a group of speakers are in the same area or dropouts and

cancellations may result in poor audio. With separated speakers, for example in different classrooms, the polarity usually is not as important since there is little speaker interaction, but good installation practice would be to keep it uniform. As a general rule, mixed polarity of speakers will cause no equipment damage, but can result in poor audio quality.

Len
via email

#2 The phase can be easily checked with no test equipment. Switch your amplifier to mono to feed the same signal to both speakers. Place the speakers face to face, leaving only a small air gap between the grills. If the speaker wires are connected properly, both speaker cones will be moving out/together at the same time, pushing a large volume of air out the gap and producing a loud sound. Reversing the leads on one speaker will cause one speaker to move in while the other is moving out, thereby moving little air out the gap resulting in a much softer sound and revealing the improper connection. Lower frequencies work best for the test.

Dale Carlsen
via email

[#7163 - July 2016]
Breaker Breaker

I'm trying to hook up my old Cobra 148 GTL CB radio for a road trip, but I can't find the antenna. My radio has SSB and I seem to recall I needed a special antenna. Any insight would be appreciated.

#1 Whether or not the CB radio has SSB capability or not does not affect the antenna used with the radio. All CB radios designed for use in the USA (assuming unmodified, factory original) operate from 26.965 MHz (ch 1) to 27.405 MHz (ch 40).

The antenna must be designed/tuned for this frequency range. There are many choices for mobile CB antennas. A web search will turn up countless suppliers. Determine how you want to mount the antenna (such as mirror bracket, trunk edge, magnetic, bumper) and then look at the length of the antenna you are comfortable using. If the vehicle must fit in a low ceiling garage, a long whip antenna may be a problem. Longer antennas will generally outperform stubby compact designs which use coils to load the antenna, although the performance difference is not likely a concern for relatively short range use that would be typical on a road trip. Many CB antennas can be tuned so they are optimized at one channel. Your 148GTL has a SWR meter built in for this purpose. For general use, tune for a low SWR on channel 20 (mid point on the CB band).

Erik von Seggern
via email

#2 You can download a complete manual for your Cobra at <https://cdn.shopify.com/s/files/1/0661/9627/files/148GTL.pdf?12272>.

You will discover there that ANY CB antenna will work just fine with this classic rig. SSB or AM — they all use the same antenna on CB.

Rick Simpson
via email

#3 I don't believe that side band requires any different antenna, but, if given a choice, I would select a unit with the best gain since side band signals are sometimes weak.

Here is what Advanced Specialties has to say about antennas at www.advancedspecialties.net/cb-radio-faq.htm:

"WHAT IS THE BEST ANTENNA FOR MY MOBILE CB RADIO?"

A - This is tough to answer & there

are many variables, but here are some good general guidelines & "Rules of Thumb" to follow. First, the Taller the antenna, the better it will work. Mount your antenna as high as possible on the vehicle & try to get at least 50% of it over the roof line. Usually, all else being equal, the Tallest, longest antenna you are comfortable with, mounted as high as possible, will give the best performance. For example, mounting a new four foot CB antenna in the same spot where you were using a two foot, will usually give better results. It wouldn't really matter what "brand name," color, or style the 2 ft antenna was. Mounting height on the vehicle & the antenna length should be more important than other considerations. Keep in mind that, generally, CB antennas that are less than three feet tall, those that "stick to the glass" & the AM/FM/CB "combo" antennas & adapters usually do not give the best performance, they are bought & sold mainly for "convenience" & "cosmetic" reasons."

Len Powell
Finksburg, MD

[#8161 - August 2016] Smart Wallet?

My old billfold was worn out over the years. I planned to retire it when I noticed in back was a coil of 10 revolutions (6 cm x 4.8 cm) with a capacitor marked 47 soldered to the ends, welded in plastic, the size of a credit card. I had never noticed this. Could it be a security feature to prevent devices from getting to my credit cards?

#1 What you have is an LC parallel resonant circuit in which the inductor (L) is a loop antenna similar to the ones found in old AM radios, and a 47 picofarad capacitor (C) tuned to resonate at the 13.56 MHz signal frequency used by credit card RFID chip readers.

At this resonant frequency, the parallel LC circuit has a very high impedance and effectively absorbs most of the RF energy from a hacker's

reader to protect the information on your credit card chip.

I bought a couple of wallets that protect RFID chips, which have a layer of aluminum foil sandwiched between the layers of leather and cloth in the wallet. It makes a Faraday cage which prevents the hacker's RF reader from stealing my card info.

Tim Brown
via email

#2 What your wallet had was an antitheft tag. See www.highlight86.com/blog/high-quality-highlight-coil-supermarket-store-retail-security-antitheft-tag-ferrite-supplier.html for a photo of a similar device. The device is simply a tuned circuit that can be disabled at the point of sale, such as by burning out an internal fuse.

Occasionally, the circuit is not burned out (or someone tries to shoplift) and in passing through the detector at the store entrance, an alarm is set off.

Bart Bresnik
via email

[#8165 - August 2016] Unwired

I want to extend my home alarm system to my garden shed. The shed has power but no simple way to get wire to it from the house. Is there a DIY wireless method to try?

#1 A simple cheap and dirty solution would be to use one of those wireless door bell setups that most hardware stores sell.

Place simple door (normally open) switches in parallel with the "door bell" switch mounted in the garden shed. Use a low current reed relay across the speaker output of the receiver in the house. Connect the normally open reed contacts to one of your alarm panel loops.

Wala, a cheap and dirty solution. You may need to add a latching relay of some sort.

Ray
Vancouver, Canada

#2 I have used the Wicked Devices 433 MHz system with an Arduino controller when it is inconvenient to run a cable. The effective range is up to a couple of hundred feet. This unit has four channels that can be used, and a lot of documentation and code is available on the Internet.

The unit is also called Nanode Transmitter & Receiver. See www.wickeddevices.com for more information.

Gene Sellier
Fairhope, AL

#3 There are a couple ways you can go with this:

1. Contact your alarm company and find out if the security panel in your home directly supports wireless devices. Most modern ones do. They would install a wireless door contact in the shed and program it to the alarm panel. Some security systems already have wireless built in or they may need to add a wireless receiver.

As a bonus, you could add on a wireless keyfob to arm/disarm your house from the driveway. This would cost more than a DIY solution but they should be able to match up the proper equipment to make the setup as reliable as possible.

2. For a more DIY approach, Linear has available a wireless transmitter and receiver that could be integrated into any security system regardless of age. "Linear D-24A" is the transmitter and "Linear D-67" is the receiver.

The transmitter uses a battery and would still need to be connected to a set of door contacts on the shed door. The receiver wires directly to your security panel to power and one zone. You would want to use a spare zone on the panel, which may need to be programmed by your alarm company. If your security panel dials out to a monitoring company, your alarm company will need to add that zone to your account so that activation of that zone would alert the proper authorities.

Eric D. Bailey
Cecilton, MD

ELECTRONET

NEW! LEAD SCREWS



starting at \$9.99

available in 4 lengths

ACTORBOTICS

Ironwood ELECTRONICS

High Power, High Endurance

1-800-404-0204

www.ironwoodelectronics.com

RoHS

ALL ELECTRONICS CORPORATION

Electronic Parts and Supplies.

www.allelectronics.com

Free 96 page catalog 1-800-826-5432

For the ElectroNet online, go to www.nutsvolts.com click **Electro-Net**

PCB, PCBA and More!

Myro

Low cost High Quality

www.myropcb.com

1-888-PCB-MYRO

Wanna read even more about electronics? Check out our book selection at store.nutsvolts.com

USB Add USB to your next project-- It's easier than you might think!

USB-FIFO • USB-UART • USB/Microcontroller Boards
RFID Readers • Design/Manufacturing Services Available

Absolutely NO driver software development required!

www.dlpdesign.com

DLP Design

ADvertiser INDEX

LOOK FOR SEARCH FOR FIND Find your favorite advertisers here!

BATTERIES/CHARGERS

Hitec2

BUYING ELECTRONIC SURPLUS

All Electronics Corp.55

CIRCUIT BOARDS

Accutrace66
AP Circuits16
ExpressPCB39
Front Panel Express LLC6
PCBFabExpress7
Saelig Co., Inc.45

COMPONENTS

All Electronics Corp.55
NTE Parts Direct33
Saelig Co., Inc.45
ServoCity67

DESIGN/ENGINEERING/REPAIR SERVICES

Accutrace66
AP Circuits16
Cleveland Institute of Electronics ...7
ExpressPCB39
Front Panel Express LLC6
PCBFabExpress7

DEVELOPMENT PLATFORMS/TOOLS

AnarenBack Cover
Technologic Systems61

EDUCATION

Cleveland Institute of Electronics ...7
Command Productions17
PoLabs8

EMBEDDED SYSTEMS

Saelig Co. Inc.45
Technologic Systems61

EVENTS

AUVSI54
CES9
Maker Faire51

ENCLOSURES

Front Panel Express LLC6

LCDs/DISPLAYS

EarthLCD19
Saelig Co., Inc.45

MICROCONTROLLERS / I/O BOARDS

Technologic Systems61

MISC./SURPLUS

All Electronics Corp.55
NTE Parts Direct33

MOTORS / MOTOR CONTROL

Hitec2
ServoCity67

RF TRANSMITTERS/RECEIVERS

Lemos International61

ROBOTICS

Cleveland Institute of Electronics ...7
Hitec2
ServoCity67

TEST EQUIPMENT

NTE Parts Direct33
Pico Technology3
PoLabs8
Saelig Co., Inc.45

TOOLS

PanaVise16
PoLabs8

WIRE, CABLE AND CONNECTORS

All Electronics Corp.55

WIRELESS PRODUCTS

AnarenBack Cover
Lemos International61
Technologic Systems61

Accutrace	66
All Electronics Corp.	55
AnarenBack Cover	
AP Circuits	16
AUVSI	54
CES	9
Cleveland Institute of Electronics	7
Command Productions	17
EarthLCD	19
ExpressPCB	39
Front Panel Express LLC	6
Hitec	2
Lemos International	61
Maker Faire	51
NTE Parts Direct	33
PanaVise	16
PCBFabExpress	7
Pico Technology	3
PoLabs	8
Saelig Co., Inc.	45
ServoCity	67
Technologic Systems	61

PRINTED CIRCUIT BOARDS

THINK YOU CAN FIND PCB PRICES THAT BEAT OURS?

WE DARE YOU.



THERE ARE NO GAMES INVOLVED IN OUR PRICING



Our Capabilities:

- From same day quick turn prototype to production in under 10 days
- Full CAD and CAM review plus design rule check on ALL Gerber files
- Materials: Fr4, Rigid, Flex, Metal Core (Aluminum), Polyimide, Rogers, Isola, etc.
- HDI Capabilities: Blind/Buried Microvias, 10+N+10, Via-in-Pad Technology, Sequential Lamination, Any Layer, etc.
- Our HDI Advantage: Direct Laser Drilling, Plasma De-Smear Technology, Laser Microvia, Conductive Plate Shut.

Take the Accutrace Challenge and see WHY OUR PRICING CANNOT BE BEATEN

Accutrace inc.

www.PCB4u.com sales@PCB4u.com

● SAM & ITAR Registered ● I SO 9001 - 2008, ● UL E33047

PROWLER

The Prowler™ offers a great starting platform for any robotics project. With heavy-duty, ball-bearing, metal geared, Premium Planetary Gear Motors and high-traction 5.4" off-road tires, this is one powerful platform!

We can't wait to see what you do with this rugged, stealthy robot!



\$219⁹⁹

PART: 637194

Electronics not included.



HIGH TORQUE



LOW PROFILE



RUGGED DESIGN

*MORE
PRODUCT
INFO!*



ACTOBOTICS[®]
DREAM • DESIGN • BUILD • REPEAT

AVAILABLE AT SERVOCITY.COM
sales@servocity.com • 620-221-0123



“Fetch more coffee, Rex!”



A giant, coffee-carrying IoT dinobot at the command of your index finger? Why not. In fact, wherever your imagination leads you, Anaren empowers you with the industry's easiest-to-use wireless connectivity platform. Scan the code to learn more and register for a chance to win a free Atmosphere MSDK.* Think. Build. Connect.



* Must be 18 to participate. No purchase necessary. North America only. Void where prohibited. Other restrictions apply.

www.anaren.com/air/win