

# DI-41 Design Idea

## TOPSwitch®-GX

### 43 W, 100/115 VAC Multi-output Set-top Box Power Supply

Application	Device	Power Output	Input Voltage	Output Voltage	Topology
Set-top Box	TOP247YN	43 W cont, 57 W pk	90 – 132 VAC	3.3 V, 5 V, 12 V, 18 V, 33 V	Flyback

#### Design Highlights

- Low cost, low component count solution
- Excellent output voltage tracking and cross-regulation – no linear regulators required
- High efficiency, >71% at 90 VAC
- Line undervoltage detection (UV) and power system surge protection (OV)
- Meets CISPR22B/EN55022B conducted EMI limits
- Differential and common mode surge immunity to 4 kV (EN61000-4-5)
- 100 kHz ring wave immunity to 4 kV (IEEE C62.41)

#### Operation

The design in Figure 1 utilizes the TOP247YN and takes advantage of many of the TOPSwitch-GX features. Line UV and OV (100 V and 450 V, respectively) are implemented using a single 2 MΩ resistor (R1). Undervoltage eliminates output glitches and overvoltage provides protection for both short duration transients

and long duration power system surges. Resistor R4 programs the internal current limit of U1 to 80% of nominal, limiting overload power.

The key performance characteristic of the circuit shown is the excellent output voltage tracking and cross-regulation. Two techniques are used to properly center the output voltages. The extra voltage drop of the ultra-fast rectifier D10 (used instead of a Schottky) centers the 5 V output at precisely 5 V and DC stacking is used to improve the regulation of 12 V, 18 V, and 30 V outputs. Ferrite bead L7 is placed in series with the 12 V, 18 V and 30 V output windings to improve centering and cross-regulation of these outputs.

Frequency jittering provides large EMI margins with simple filtering. Primary soft-start minimizes component stress during start-up and a soft-finish capacitor (C20) eliminates start-up output overshoot.

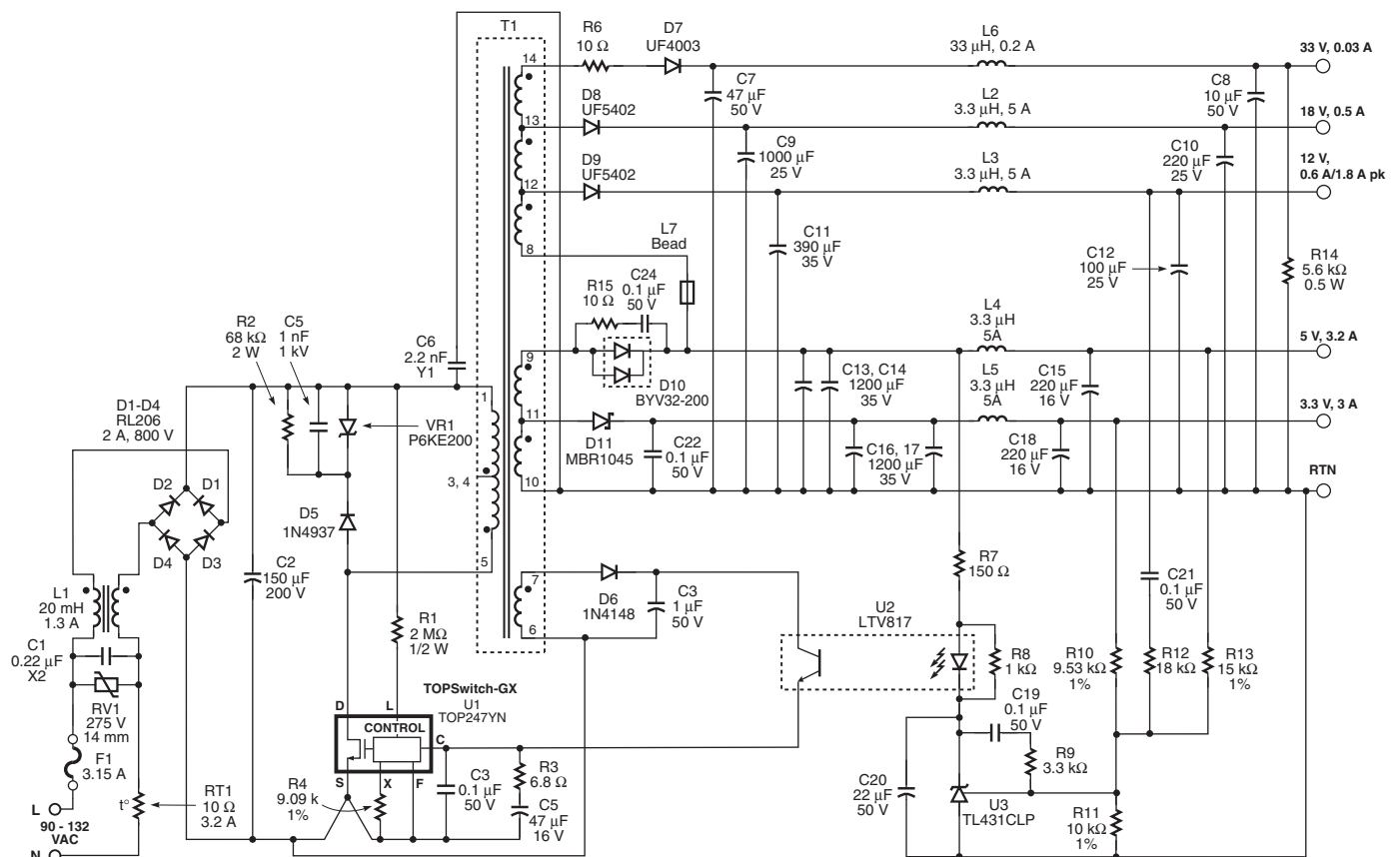

Figure 1. TOPSwitch-GX 43 W Continuous, 57 W Peak Set-Top Box Power Supply.

PI-3389-101408

## Key Design Points

- Use  $K_{RP}$  (Ripple-to-peak current ratio) in the range of 0.4–0.6 for higher efficiency, and tighter cross-regulation. Use  $V_{OR}$  (reflected output voltage) of 90 V to 110 V for optimum performance.
- PCB traces which carry high switching currents should be short and wide to reduce EMI.
- Reduce leakage inductance and improve cross-regulation by filling each winding layer across the entire width of the bobbin.
- Resistor R14 provides a small amount of pre-load on the 33 V output to prevent peak charging due to leakage spikes.
- R5 and C5 reduce power dissipation in VR1.

Output Voltage (V)	Load Range (%)	Cross Regulation (%)																				
		-8	-7	-6	-5	-4	-3	-2	-1	0	1	2	3									
3.3	1-3																					
5	1-3.2																					
12	0.3-0.6																					
30	0.01-0.03																					

Table 2. Worst Case Output Cross Regulation – Outputs Taken from Minimum to Maximum Load and Line from 85 VAC to 132 VAC.

## Transformer Parameters

<b>Core Material</b>	ERL28, Nippon Ceramic NC-2H material or equivalent, gapped for ALG of 128 nH/t <sup>2</sup>
<b>Bobbin</b>	ERL28 14 pin, Vertical, Jinbo Industrial JB-0039 or equivalent
<b>Winding Details</b>	Primary: 30T + 23T, 25 AWG Shield: 1T, 0.6" × 0.001" Cu foil Bias: 7T, 2 × 27 AWG 3.3 V: 2T, 0.6" × 0.005" Cu foil 5 V: 1T, 0.6" × 0.005" Cu foil 12 V: 4T, 2 × 27 AWG 18 V: 3T, 2 × 27 AWG 33 V: 6T, 27 AWG (2 × 27 AWG = Bifilar 27 AWG)
<b>Winding Order (pin numbers)</b>	Apply 3.2 mm tape margin to both sides of bobbin. Primary (4–3), tape, Shield (1–NC), tape, Bias (6–7), 3 × tape, 5 V (9–11), 3.3 V (11–10), tape, 12 V (12–8), 18 V (13–12), 33 V (14–13), 3 × tape, Primary (3–1), 3 × tape
<b>Inductance</b>	Primary: 356 μH Leakage: 11 μH (maximum)
<b>Primary Resonant Frequency</b>	650 kHz (minimum)

Table 1. Transformer Parameters. (AWG = American Wire Gauge, NC = No Connection)

Power Integrations  
5245 Hellyer Avenue  
San Jose, CA 95138, USA.  
Main: +1 408-414-9200  
Customer Service  
Phone: +1-408-414-9665  
Fax: +1-408-414-9765  
Email: usasales@powerint.com

On the Web  
www.powerint.com

Power Integrations reserves the right to make changes to its products at any time to improve reliability or manufacturability. Power Integrations does not assume any liability arising from the use of any device or circuit described herein. POWER INTEGRATIONS MAKES NO WARRANTY HEREIN AND SPECIFICALLY DISCLAIMS ALL WARRANTIES INCLUDING, WITHOUT LIMITATION, THE IMPLIED WARRANTIES OF MERCHANTABILITY, FITNESS FOR A PARTICULAR PURPOSE, AND NON-INFRINGEMENT OF THIRD PARTY RIGHTS. The products and applications illustrated herein (transformer construction and circuits external to the products) may be covered by one or more U.S. and foreign patents or potentially by pending U.S. and foreign patent applications assigned to Power Integrations. A complete list of Power Integrations' patents may be found at [www.powerint.com](http://www.powerint.com). Power Integrations grants its customers a license under certain patent rights as set forth at <http://www.powerint.com/ip.htm>.

The PI logo, TOPSwitch, TinySwitch, LinkSwitch, DPA-Switch, PeakSwitch, EcoSmart, Clampless, E-Shield, Filterfuse, StackFET, PI Expert and PI FACTS are trademarks of Power Integrations, Inc. Other trademarks are property of their respective companies. ©2002, Power Integrations, Inc.